

(No Model.)

J. BUTLER.

Electro Magnetic Apparatus for Medical Use.

No. 237,167.

Patented Feb. 1, 1881.

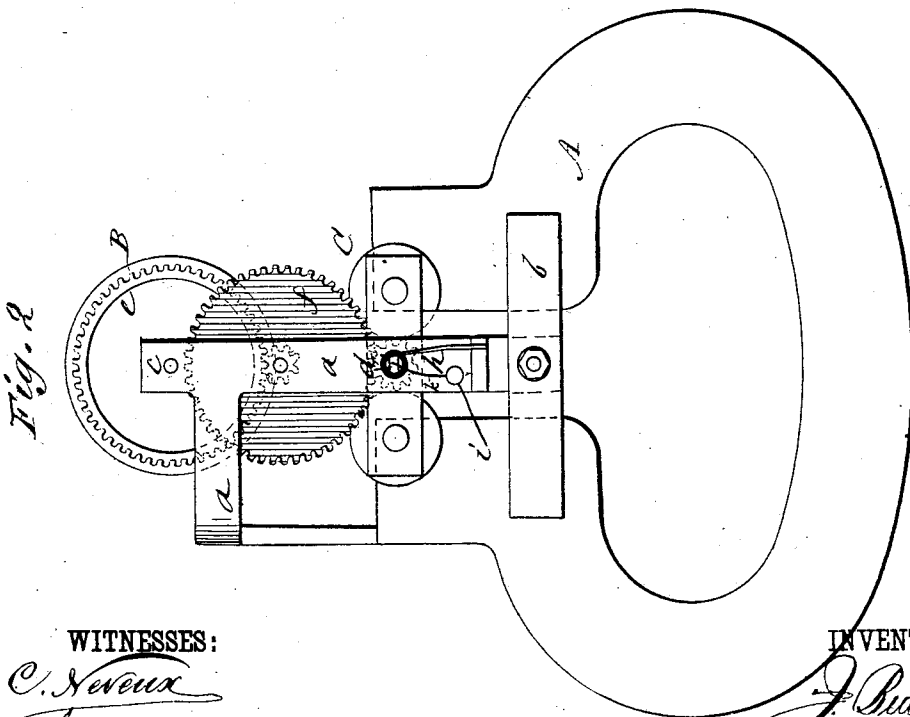
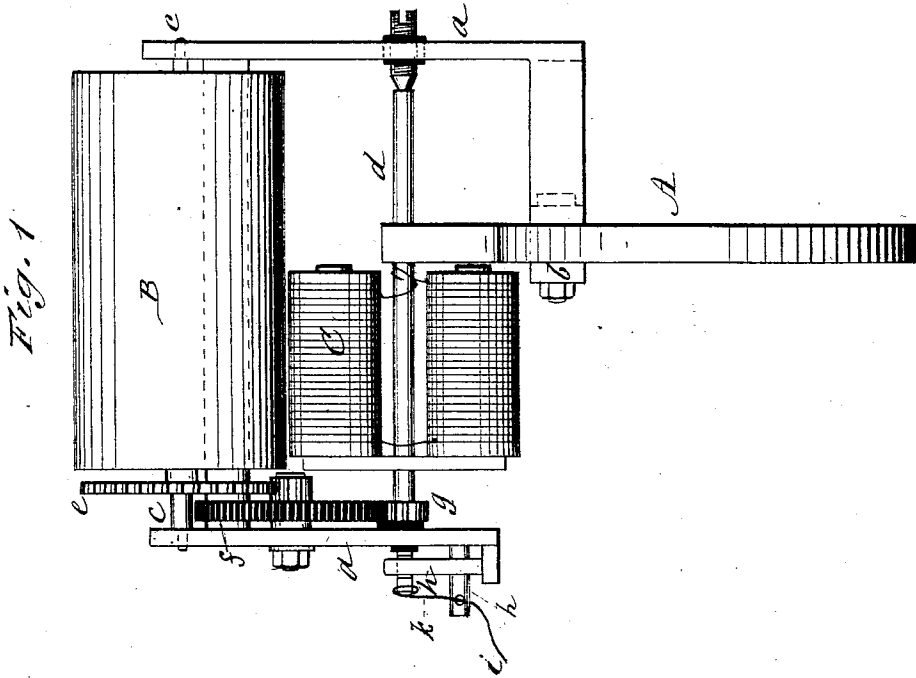

WITNESSES:  
*C. Xerox*  
*C. Sedgwick*

INVENTOR:  
*J. Butler*  
BY *Mum & Co*  
ATTORNEYS.

# UNITED STATES PATENT OFFICE.

JOHN BUTLER, OF NEW YORK, N. Y.

## ELECTRO-MAGNETIC APPARATUS FOR MEDICAL USE.

SPECIFICATION forming part of Letters Patent No. 237,167, dated February 1, 1881.

Application filed October 16, 1880. (No model.)

*To all whom it may concern:*

Be it known that I, JOHN BUTLER, of the city, county, and State of New York, have invented a new and Improved Electro-Magnetic Apparatus for Medical Use; of which the following is a specification.

My invention consists in an electro-magnetic apparatus having one or both electrodes fitted as a roller or rollers for use in manipulations of the muscles, so that magnetic and mechanical treatment can be combined in one operation. The roller is hung on the permanent magnet and geared to give revolution. The armature and the permanent magnet serve as a handle by which the apparatus can be operated.

In the accompanying drawings, forming part of this specification, Figure 1 is a side elevation of an electro-magnetic apparatus embodying my improvements, and Fig. 2 is an elevation at right-angles to Fig. 1.

Similar letters of reference indicate corresponding parts.

A is a permanent horseshoe-magnet, the shape being, however, varied from that commonly used, for greater convenience in using the magnet as a handle.

*a a a* are the bars of a frame that is attached to magnet A by a clamp, *b*.

B is a metal roller of suitable length and diameter, hung by its trunnions *c c* on the end bars, *a a*, of the frame, so that the roller is sustained a short distance beyond the poles of the magnet A.

*d* is a spindle hung in suitable bearings in bars *a* parallel with roller B, and carrying an electro-magnet C. The spindle *d* is in line with the face of the poles of the permanent magnet, or it may pass between the poles, and the poles of the electro-magnet are toward the permanent magnet, in suitable relation thereto.

On one axis of roller B is fixed a gear-wheel, *e*, that connects, through intermediate gears *f* fitted on a bar, with a pinion, *g*, on spindle *d*, so that the revolution of roller B shall give rapid rotation to the electro-magnet or armature C. One intermediate gear, *f*, is made of non-conducting material.

On one bar, *a*, a contact-spring, *h*, is fitted, and also with a second spring, *k*, that is in continuous contact with spindle *d*. The wire will be provided with a metallic or other rheophore, covered with sponge at its outer end, as one electrode of the machine, the roller B being the other electrode.

*i* is a wire having connection with spring *h*, and also with a second spring, *k*, that is in continuous contact with spindle *d*. The wire will be provided with a metallic or other rheophore, covered with sponge at its outer end, as one electrode of the machine, the roller B being the other electrode.

In use the operator, holding the apparatus by the magnet A, works the roller B over the muscles, and thus manipulates them mechanically, while at the same time, the other electrode being applied to any part of the patient's body, the current induced by the rotation of the electro-magnet passes through the patient. The portions being manipulated are thus directly treated electrically. At the same time they are mechanically manipulated.

I do not limit myself to the details exactly as described in constructing the apparatus, as they may be varied within the scope of my invention.

Both electrodes may be formed as rollers, for use as specified.

Having thus described my invention, I claim as new and desire to secure by Letters Patent—

1. An electro-magnetic apparatus for medical use, having one electrode formed as a driving-roller, and fitted in a handle for use, substantially as shown and described, and for the purposes set forth.

2. In electro-magnetic apparatus for medical use, the permanent magnet A, manipulating-roller B, carried by the permanent magnet, and electro-magnet C, fitted for rotation by the roller, combined, substantially as shown and described, for operation and use as specified.

JOHN BUTLER.

Witnesses:

GEO. D. WALKER,  
C. SEDGWICK.