

F. KIRCHOFF.
ANIMAL HOLDING CRATE.
APPLICATION FILED AUG. 10, 1910.

994,752.

Patented June 13, 1911.

3 SHEETS—SHEET 2.

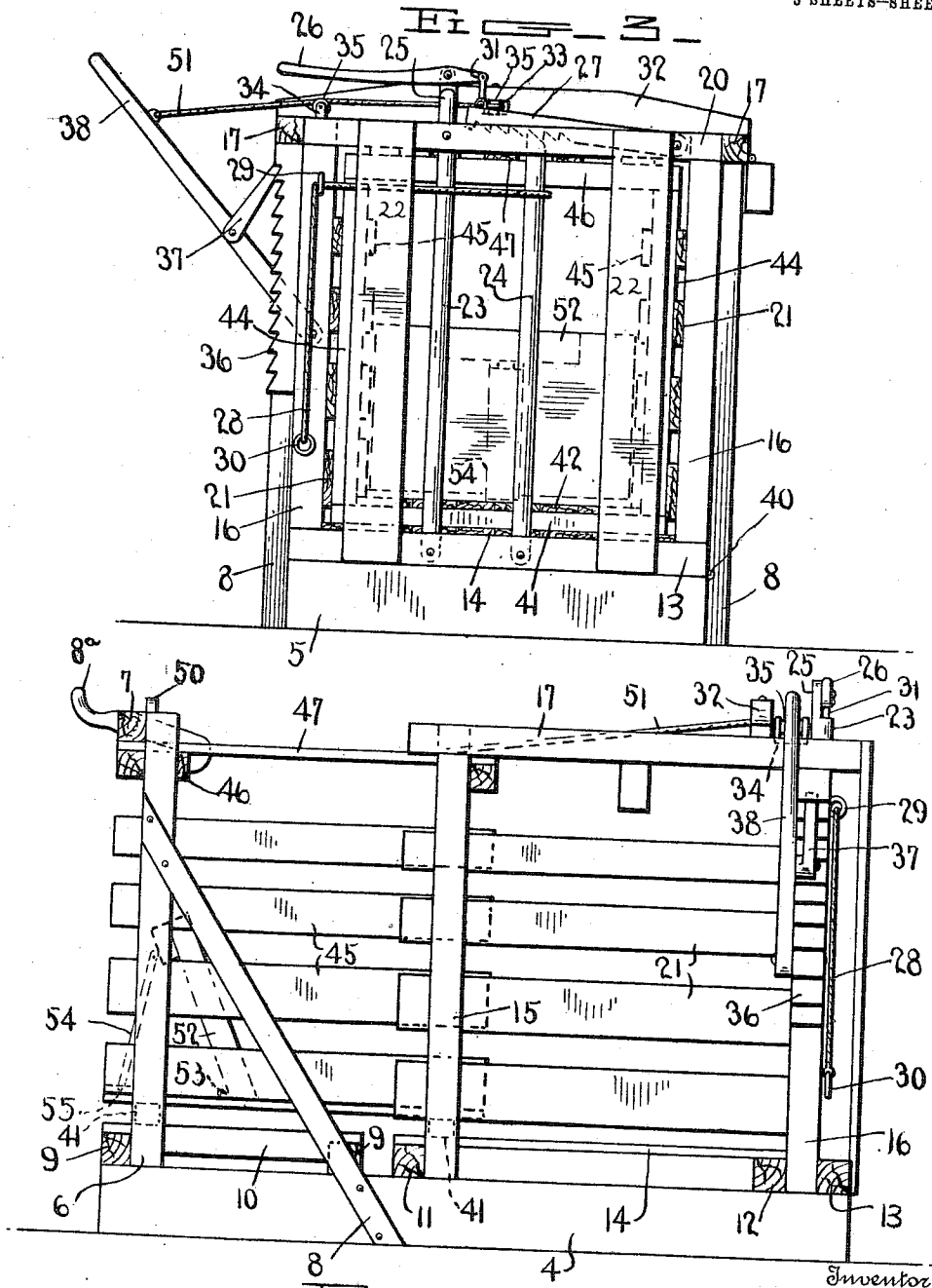

Witnesses
L. B. James
C. M. Howell
 By *Fred Kirchoff*
James & James
 Attorney

F. KIRCHOFF.
 ANIMAL HOLDING GRATE.
 APPLICATION FILED AUG. 19, 1910.

994,752.

Patented June 13, 1911.

3 SHEETS—SHEET 3.

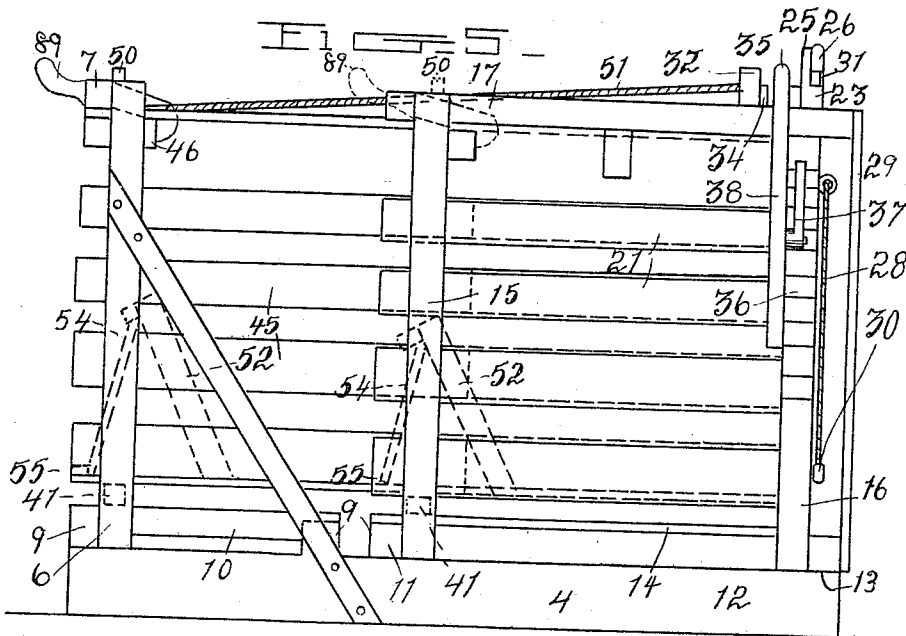
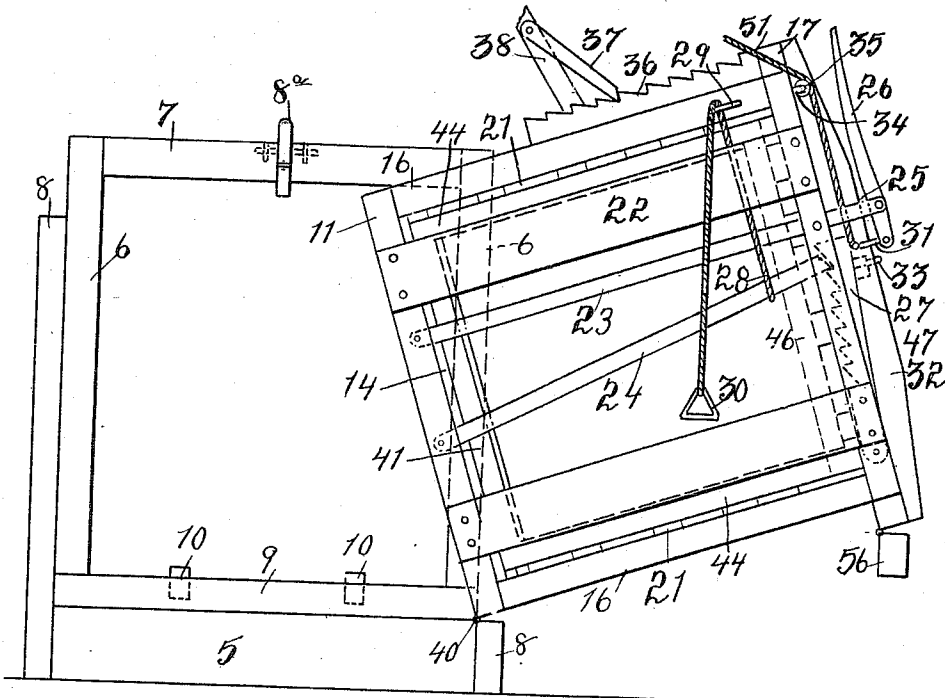

Witnesses
 Clayton L. New
 F. J. Campbell

FI — — — — —

Inventor
 Fred Kirchoff
 By *Shuck Shuck*
 Attorneys

UNITED STATES PATENT OFFICE.

FREDERICK KIRCHOFF, OF MERIDEN, IOWA.

ANIMAL-HOLDING CRATE.

994,752.

Specification of Letters Patent. Patented June 13, 1911.

Application filed August 19, 1910. Serial No. 577,947.

To all whom it may concern:

Be it known that I, FREDERICK KIRCHOFF, a citizen of the United States, residing at Meriden, in the county of Cherokee and State of Iowa, have invented new and useful Improvements in Animal-Holding Crates, of which the following is a specification.

This invention relates generally to an improvement in animal-holding crates, and more particularly to crates of the character described, in which a hog or other animal is held in such a position that it can be easily operated upon.

The principal object of this invention is to provide a crate of the class described which is extremely simple in construction, easy of operation, and cheap to manufacture.

With these and other objects in view, the invention consists in the construction and novel combination of parts hereinafter more fully described, illustrated in the accompanying drawings, and pointed out in the claims hereto appended; it being understood that various changes in the form, proportion, size and minor details of construction, within the scope of the claims, may be resorted to without departing from the spirit or sacrificing any of the advantages of the invention.

In the drawings, Figure 1 is a top plan view of the crate showing the auxiliary frame in its normal or extended position. Fig. 2 is an end elevation showing the auxiliary frame telescoped within the main frame and the said two frames swung laterally from the supporting frame. Fig. 3 is a rear end view of the crate, and Fig. 4 is a side elevation of the crate, with the parts in the position illustrated in Fig. 1. Fig. 5 is an end elevation showing the swinging part of the crate partly swung over, and Fig. 6 is a side elevation showing the position of some of the parts in dotted lines.

Like reference numerals designate corresponding parts in all the figures of the drawings.

Referring to the drawings, the invention comprises a base frame consisting of side and end members 4 and 5, respectively. Projecting upwardly from the front corners of the frame are uprights 6, 6, connected at their upper ends by a bar 7, said uprights being suitably braced by members 8, 8. A

catch 8^a is pivoted centrally to the said bar 7 for a purpose hereinafter described. Spaced transverse members 9, 9, are secured to the top face of the frame near the front end and form end supports for runners 10, 10, which are arranged longitudinally of said frame.

The invention further comprises a main frame which consists of spaced transverse base members 11, 12 and 13, the first two members forming end supports for a flooring 14. Secured to the opposite ends of the member 11 are uprights 15, 15, and arranged between and secured to the opposite ends of the members 12 and 13 are uprights 16, 16. The upper ends of the said uprights 15 and 16 are secured by longitudinal members 17, 17, and transverse members 18, 19 and 20, the two last mentioned members being arranged on either side of the uprights 16 and directly above the base members 12 and 13. Spaced slats 21, or other suitable sidings, are secured to the said uprights. Spaced members 22, 22 are arranged at the rear end of the said frame and are connected to the transverse members 18 and 20.

Arranged intermediate the members 22 is a stanchion which consists of two gripping arms 23 and 24, respectively, said arms being arranged between the base members 12 and 13 and the top members 19 and 20. The arm 23 is positively secured in position by bolts or other suitable fastening means, and the upper end 25 thereof projects above the frame to form a support for an operating-lever 26 which is pivoted thereon. The other arm 24 is pivotally mounted at its lower end so that its free or upper end can thereby be shifted to and from the first-mentioned arm 23. A toothed locking pawl 27 is also arranged between and pivoted to the members 19 and 20 and is adapted, by reason of its own weight, to automatically lock the pivoted arm 24 in any adjusted position.

After the animal's head has been positioned between the arms of the stanchion, as will be hereinafter more fully explained, the pivoted arm 24 is drawn against the neck of the animal by means of a cord 28 which passes through a screw-eye 29 carried by one of the uprights 16, and is provided with a hand-grip 30. Connected to the free end of the pawl 27 and to the short arm of the lever 26 is a link 31. It will therefore

be seen that by depressing the said lever the pawl will be disengaged from the pivoted arm 24. The main frame is further braced by a transverse member 32 which is provided with a pulley 33 mounted centrally therein on a vertical axis. A bracket 34 is mounted upon one of the front corners of the frame and forms a support for a horizontally rotating pulley 35. Secured to one side of one of the front uprights 16 and contiguous to the last-mentioned pulley 35, is a rack bar 36 adapted to be engaged by a pawl 37 pivotally mounted on a hand-lever 38 which is pivoted to the said upright 16. A guide-rod 39 is centrally and longitudinally arranged to be supported at its ends by the transverse members 18 and 19 of the frame. This main frame is normally supported by the base frame and is connected thereto by hinges 40, said hinges being arranged on one side of the base frame in such a manner that the main frame may be swung laterally therefrom.

The invention further comprises an auxiliary frame which consists of spaced transverse base members 41 adapted to form end supports for a flooring 42. The front base member is centrally provided with a depending cleat 43 adapted to slide between the runners 10, 10 of the base frame. This auxiliary frame is smaller than the main frame and is adapted to be telescoped within the latter, as will be hereinafter more fully explained. Secured to the base members 41 are uprights 44 adapted to form supports for slats 45 which form the sides of the said auxiliary frame. Transverse members 46 respectively connect the upper end of the said uprights and form end supports for top slats 47. The rear transverse member 46 is provided with a screw-eye which engages the guide-rod 39 and thereby supports the rear end of the auxiliary frame. The rear lower transverse member is provided with spaced depressions 48, and the upper member with alined openings 49. Rails 50 project through the said openings and into the depressions and thereby close the rear end of the said frame.

It will be observed that when the frame is in its rearmost position, the catch 8^a will normally engage the upper transverse member and thereby lock the said frame from inward movement. A cord 51 has one end connected to the said upper transverse member and extends around the pulley 33, over the pulley 35, and has its other end connected to the hand-lever 38. A transverse back-board 52 is arranged near the rear of the auxiliary frame and is secured to the floor thereof by hinges 53. A brace 54 has one end hingedly connected to the front face of the back-board. The free end of said brace is adapted to be seated in a recess 55 formed in the front lower transverse mem-

ber of the said frame and thereby support the said board in a normally and forwardly inclined position.

From the foregoing it will be observed that when the crate is to be used the rails 50 are withdrawn and the back-board is dropped. A hog or other animal is then driven within the two telescopically arranged crates, the back-board elevated and the rails inserted to close the rear opening. The catch 8^a is then released, after which the hand-lever 38 is depressed. As the hand-lever is depressed the auxiliary frame, through the medium of the cord 51, is caused to be slid or telescoped within the main frame. As this movement takes place the animal's head is caused to be projected through the arms of the stanchion. At this point the pivoted arm 24 of the stanchion is pressed tightly against the animal's neck by means of the operating cord and the pivoted pawl will automatically lock the said arm in position. Upon the further depression of the hand-lever 38 the auxiliary frame and, consequently, the back-board will tightly bear against the animal. When the limit of movement has been reached, the pawl 37 of the hand-lever engages the rack bar 36 and thereby locks the auxiliary frame in its adjusted position. After the animal has been secured in this manner, the main frame, together with the auxiliary frame, is swung over to one side on the base frame as before mentioned, and a supporting leg 56 which is pivotally mounted on the main frame, normally supports the two telescoping frames in proper relation to the ground. By reason of the fact that these frames are swung outwardly as above described, freedom of movement is thereby given to the operator, the rails 50 being withdrawn to permit freedom of movement in operating.

Having thus described the invention, what is claimed as new and desired to secure Letters Patent upon, is:—

1. In a crate of the class described, the combination with a base frame, of a main frame hingedly mounted thereon to swing laterally, and an auxiliary frame movably mounted on the base frame and adapted to be telescoped within the said main frame to swing therewith.

2. In a crate of the class described, the combination with a base frame, of a main frame hingedly mounted thereon to swing laterally, a stanchion arranged at one end of the main frame, an auxiliary frame movably mounted on the base frame and adapted to be telescoped within the said main frame to swing therewith, and a back-board secured to the end of the auxiliary frame opposite the stanchion.

3. In a crate of the class described, the combination with a base frame, of a main frame hingedly mounted thereon to swing

laterally, a stanchion arranged at one end of the main frame, said stanchion comprising a fixed and a pivoted arm, means carried by the frame for locking the pivoted arm in an adjusted position, and an auxiliary frame movably mounted on the base frame and adapted to be telescoped within the said main frame to swing therewith.

4. In a crate of the class described, the combination with a base frame, of a main frame hingedly mounted thereon to swing laterally, a stanchion arranged at one end of the main frame, said stanchion comprising a fixed and a pivoted arm, means carried by the frame for locking the pivoted arm in an adjusted position, means carried by the fixed arm for releasing the said locking means, and an auxiliary frame movably mounted on the base frame and adapted to be telescoped within the said main frame to swing therewith.

5. In a crate of the class described, the combination with a base frame, of a main frame hingedly mounted thereon to swing laterally, a stanchion arranged at one end of the main frame, said stanchion comprising a fixed and a pivoted arm, a toothed pawl pivoted to the frame for locking the pivoted arm in an adjusted position, releasing means for the pawl, said means comprising a lever pivoted on the fixed arm and having its short arm connected to the free end of the pawl, and an auxiliary

frame movably mounted on the base frame and adapted to be telescoped within the said main frame to swing therewith.

6. In a crate of the class described, the combination with a base frame, of a main frame hingedly mounted thereon to swing laterally, a centrally and longitudinally arranged guide-rod secured to the frame, and an auxiliary frame movably mounted on the base frame to slide longitudinally within the main frame and having one end connected to and supported by said guide-rod.

7. In a crate of the class described, the combination with a base frame, of a main frame hingedly mounted thereon to swing laterally, an auxiliary frame movably mounted on the base frame and adapted to be telescoped within the said main frame to swing therewith, operating means for said auxiliary frame comprising pulleys arranged on the main frame, a lever, and a flexible connection between the auxiliary frame and the lever, and means for locking the lever and consequently the auxiliary frame in its adjusted position.

In testimony whereof I have hereunto set my hand in presence of two subscribing witnesses.

FRED. KIRCHOFF.

Witnesses:

JOHN ARTHUR,
W. K. HERRICK.