

Dec. 23, 1958

F. J. McCONNELL

2,865,193

PADLOCK

Filed May 2, 1956

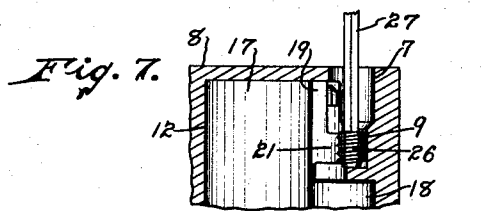
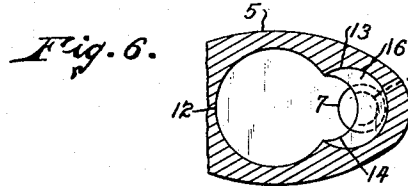
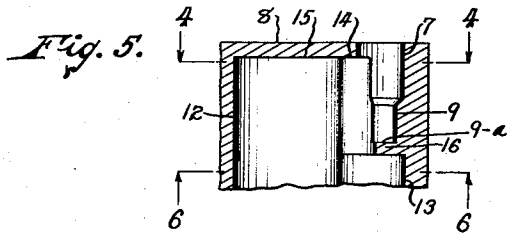
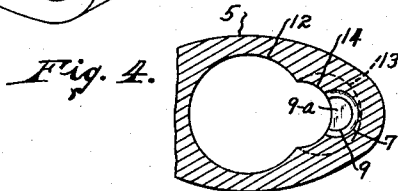
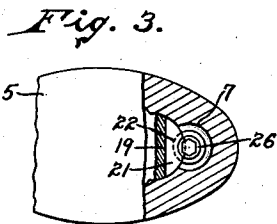
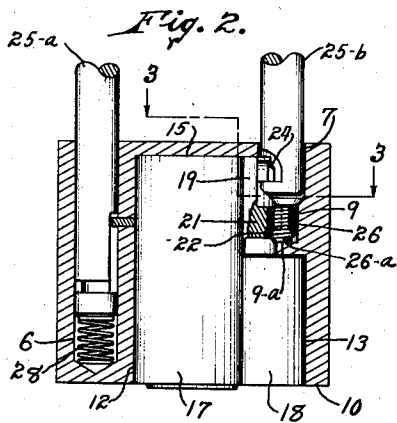
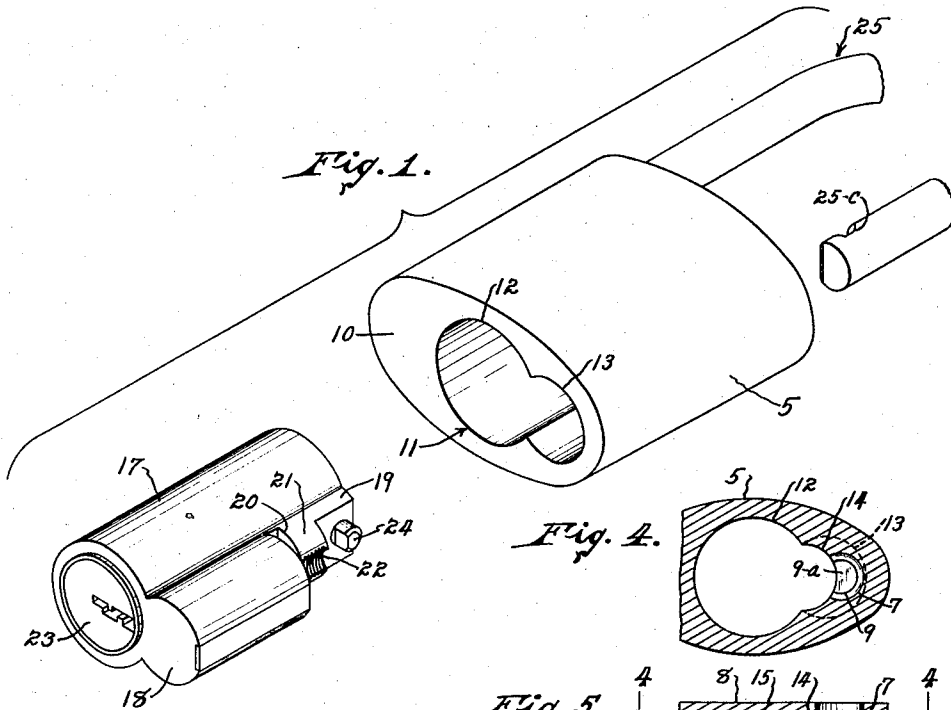

INVENTOR.  
FRANK J. McCONNELL

BY *Louis V. Lucia*

ATTORNEY

1

2,865,193

**PADLOCK**

Frank J. McConnell, New Britain, Conn., assignor to  
The American Hardware Corporation, New Britain,  
Conn., a corporation of Connecticut

Application May 2, 1956, Serial No. 582,178

1 Claim. (Cl. 70—38)

This invention relates to a padlock, and more particularly to a padlock of the type having a removable lock unit, or core, which controls the movement of the padlock shackle.

The primary object of the present invention is to provide improved means for retaining the removable lock unit of such a padlock in the body thereof.

A further object of this invention is to provide retaining means for the removable lock unit of such a padlock which are accessible only through the hole in the lock body which is provided for the short leg of the shackle, so that said retaining means will be concealed when the shackle is in locked position.

A still further object of this invention is to provide, for such a padlock, improved retaining means which may be easily and quickly assembled and disassembled when the shackle of the padlock is in open position.

Further objects and advantages of the present invention will be more clearly understood from the following description and the accompanying drawings in which:

Fig. 1 is an isometric view illustrating the padlock body and the lock unit which is insertable therewith.

Fig. 2 is a side view of the assembled padlock, partially in central vertical section, illustrating the shackle in locked position and the retaining means for the lock unit.

Fig. 3 is a fragmentary, sectional, top view of said padlock taken substantially on line 3—3 of Fig. 2.

Fig. 4 is a similar view, on line 4—4 of Fig. 5, showing the padlock body with the lock unit removed therefrom.

Fig. 5 is a fragmentary side view of said padlock body in central vertical section.

Fig. 6 is a fragmentary bottom view of said padlock body taken on line 6—6 of Fig. 5.

Fig. 7 is a fragmentary side view of the padlock, partially in central vertical section, illustrating the manner in which the retaining means for the lock unit is assembled in the padlock.

My invention is applicable to removable core padlocks of many different forms, and it will be understood that the padlock illustrated in the accompanying drawing shows merely one embodiment of the invention.

Referring now to the drawing, the numeral 5 denotes the body of the padlock which is fabricated from a solid block of suitable metal, preferably brass, and is provided with a pair of spaced parallel holes 6 and 7, which extend into the body from the upper face 8 thereof. A recess 9, which is of a smaller diameter than the hole 7, is disposed coaxially with respect to said hole and extends into the body from the bottom thereof; the diameter of said recess being determined by the major diameter of the retaining screw which is to be used in the padlock as will be hereinafter more fully described.

Extending into the body from its opposite face 10 is a socket 11 consisting of parallel intersecting bores 12, 13 and 14. The bore 12 is located centrally of the body and extends therewith for approximately its entire length, terminating in a flat end wall 15. The bore 13 is con-

2

siderably shorter than the bore 12 and terminates in spaced relation to the bottom of the recess 9 to provide a wall 16 therebetween whose flat upper surface forms the bottom 9-a of the recess 9. The bore 14 is located between the bore 12 and the hole 7 and the recess 9 extends from the top of the bore 13 to the top of the bore 12. When the bore 14 is formed during fabrication of the padlock body, the material between the hole 7 and the recess 9 and the bore 12 is removed. Referring to Figs. 4, 5 and 6, it will thus be seen that the recess 9, which is disposed laterally of the bores 12 and 14, communicates therewith.

The lock unit, or core, which is received in the socket 11 in the body of the padlock is best illustrated in Fig. 1. Said lock unit consists of an elongated cylindrical housing 17 and an integral laterally extending cylindrical pin tumbler chamber 18, and is adapted to fit snugly in the socket 11. An extension 19 is provided on the upper end of the housing 17, in alignment with the chamber 18, and said extension is separated from said chamber by a slot 20. A laterally extending projection 21 is formed on the lower end of the extension 19 and the side walls of the said extension and projection are curved to conform to the shape of the bore 14. The projection 21 is provided, on its outer end, with screw threads 22 which are formed by any suitable machining operation and extend for the entire length thereof. The said screw threads are of a size to receive a set screw having an outside diameter equal to the diameter of the recess 9.

A key plug 23 is rotatably mounted in the cylindrical housing 17 and is locked against rotation relatively to said housing by suitable pin tumblers that are contained within the chamber 18 and operate in a conventional manner. A locking bolt 24 extends radially from the housing 17 through the extension 19 and said locking bolt is adapted to be withdrawn upon rotation of the key plug, by a suitable key, through a conventional lock mechanism, not shown, in the housing 17. The locking bolt is normally retained in projected position, as shown in Figs. 1 and 2, by suitable spring means contained within said housing.

The padlock illustrated herein is equipped with a conventional J-shaped shackle 25 having a long leg 25-a and a short leg 25-b. The long leg is received in the hole 6 in the body 5 and is mounted for sliding and rotational movement therein. The short leg 25-b of the shackle is received in the hole 7 and contains a notch 25-c adjacent its free end which receives the locking bolt 24 when the shackle is in locked position.

When the lock unit is inserted into the socket 11, the cylindrical housing 17 will be received in the bore 12 and the pin tumbler housing 18 will be received in the bore 13. The lateral extension 19 will fit within the bore 14 and, as best illustrated in Figs. 2, 3 and 7, the projection 21 will be located adjacent the recess 9 and will form a portion of the wall thereof. The screw threads 22 formed on said projection will then project into said recess.

The lock unit is retained in the body of the padlock by a retaining screw 26 which is preferably a socket set-screw which is insertable into the recess 9 through the hole 7 in the top of the padlock body with a wrench 27 provided therefor. The said screw fits snugly within the recess 9 and its threads engage the threads 22 on the projection 21 so that, upon rotation of the screw by the wrench, it will be threaded downwardly into the recess 9 until the bottom end 26-a thereof engages the abutment surface formed by the bottom 9-a of the recess. As the said screw is tightened against the bottom of the recess 9, it will, through its engagement with the threads 22, urge the lock unit tightly into the socket 11 and prevent removal thereof. When the shackle is in locked po-

3

sition, as illustrated in Fig. 2; the short leg 25-b conceals the retaining screw 26 and prevents access thereto.

When access to the set-screw is desired, the locking bolt 24 is retracted with a suitable key to release the shackle 25. The shackle will be projected outwardly into its open position by the conventional spring 28 that is contained in the hole 6 to remove the short leg 25-b from the hole 7. The locking bolt 24 may then be retained in retracted position with the key to permit insertion of the wrench 27 through the hole 7 into the socket normally provided in the set-screw.

I claim:

A padlock comprising a body having a bore extending longitudinally thereinto from one end and a hole extending thereinto from its opposite end parallel to and intersecting said bore along one side thereof, the outer end of said hole being adapted to receive the leg of a shackle and the inner end being of reduced diameter forming a coaxial recess communicating with said bore and having a bottom wall, a removable lock unit contained in said

4

bore including a housing having a tumbler carrying portion and a separate projection extending laterally from the housing toward said hole and containing a recess in the surface thereof completing the recess in said lock body, the wall of the recess in said projection being provided with screw threads, and a retaining screw disposed in the recess in said body in threaded engagement with the screw threads on said projection and acting against said bottom wall to retain the lock unit in said bore, said retaining screw being accessible through the shackle receiving hole and being concealed by the leg of said shackle when in locked position.

#### References Cited in the file of this patent

##### UNITED STATES PATENTS

729,792	Page	June 2, 1903
1,093,080	Shipman	Apr. 14, 1914
1,607,758	Junkunc	Nov. 23, 1926
2,282,983	Lach	May 12, 1942
2,509,711	Williams	May 30, 1950