



- (51) International Patent Classification:  
*F25B 9/10* (2006.01)      *F25B 9/14* (2006.01)  
*F25D 19/00* (2006.01)
- (21) International Application Number: PCT/EP2015/054945
- (22) International Filing Date: 10 March 2015 (10.03.2015)
- (25) Filing Language: English
- (26) Publication Language: English
- (30) Priority Data: 1406836.5      16 April 2014 (16.04.2014)      GB
- (71) Applicant: SIEMENS PLC [GB/GB]; Faraday House, Sir William Siemens Square, Frimley, Camberley GU16 8QD (GB).
- (72) Inventor: ASTRA, Eugene; 50 Manston Close, Oxford OX29 4FB (GB).

- (74) Agents: FRENCH, Clive Harry et al.; Siemens Aktiengesellschaft, Postfach 22 16 34, 80506 Munich (DE).
- (81) Designated States (*unless otherwise indicated, for every kind of national protection available*): AE, AG, AL, AM, AO, AT, AU, AZ, BA, BB, BG, BH, BN, BR, BW, BY, BZ, CA, CH, CL, CN, CO, CR, CU, CZ, DE, DK, DM, DO, DZ, EC, EE, EG, ES, FI, GB, GD, GE, GH, GM, GT, HN, HR, HU, ID, IL, IN, IR, IS, JP, KE, KG, KN, KP, KR, KZ, LA, LC, LK, LR, LS, LU, LY, MA, MD, ME, MG, MK, MN, MW, MX, MY, MZ, NA, NG, NI, NO, NZ, OM, PA, PE, PG, PH, PL, PT, QA, RO, RS, RU, RW, SA, SC, SD, SE, SG, SK, SL, SM, ST, SV, SY, TH, TJ, TM, TN, TR, TT, TZ, UA, UG, US, UZ, VC, VN, ZA, ZM, ZW.
- (84) Designated States (*unless otherwise indicated, for every kind of regional protection available*): ARIPO (BW, GH, GM, KE, LR, LS, MW, MZ, NA, RW, SD, SL, ST, SZ, TZ, UG, ZM, ZW), Eurasian (AM, AZ, BY, KG, KZ, RU, TJ, TM), European (AL, AT, BE, BG, CH, CY, CZ, DE, DK, EE, ES, FI, FR, GB, GR, HR, HU, IE, IS, IT, LT, LU, LV, MC, MK, MT, NL, NO, PL, PT, RO, RS, SE, SI, SK,

[Continued on next page]

- (54) Title: METHOD AND APPARATUS FOR THERMALLY DISCONNECTING A CRYOGENIC VESSEL FROM A REFRIGERATOR

FIG 3

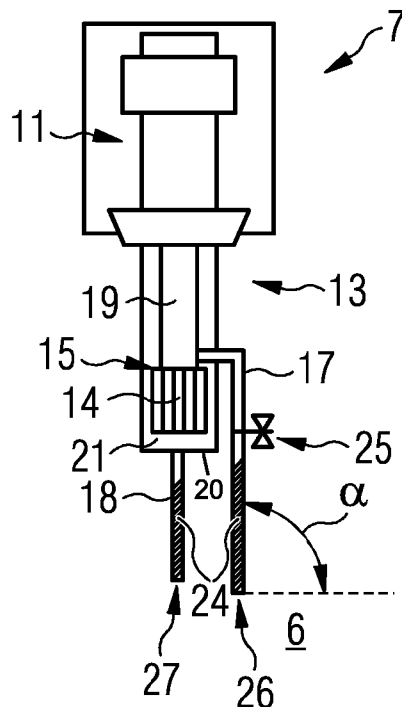

- (57) Abstract: The present invention relates to a method of thermally disconnecting a cryogenic vessel (2) of a cryostat (1) from a refrigerator (7), e.g. during transportation of the cryostat (1). In order to provide a simple and reliable technique for thermally disconnecting the refrigerator (7) from the cryogenic vessel (2), the cryogenic vessel (2) is connected with the refrigerator (7) by means of an input channel (17) and an output channel (18), wherein the input channel (17) and the output channel (18) are adapted to provide a loop system for a convection circulation of cryogen through the refrigerator (7).

SM, TR), OAPI (BF, BJ, CF, CG, CI, CM, GA, GN, GQ, GW, KM, ML, MR, NE, SN, TD, TG). **Published:**

— with international search report (Art. 21(3))

METHOD AND APPARATUS FOR THERMALLY DISCONNECTING  
A CRYOGENIC VESSEL FROM A REFRIGERATOR

The present invention relates to a method of thermally  
5 disconnecting a cryogenic vessel of a cryostat from a  
refrigerator, e.g. during transportation of the cryostat.  
Furthermore, the present invention relates to a cryostat.

In an MRI (magnetic resonance imaging) system, a cryostat may  
10 be employed, said cryostat comprising a cryogenic vessel  
holding a liquid cryogen, e.g. liquid helium, for cooling the  
superconducting magnet coils. A refrigerator provides active  
refrigeration to cool the cryogen within the cryogenic  
vessel.

15

However, in case of transportation of the superconducting  
magnet system, e.g. from the manufacturing site to the  
operational site, the refrigerator is inactive, and is  
incapable of diverting the heat load from the cryogen vessel.  
20 Instead, the refrigerator itself provides a thermal path for  
ambient heat to reach the cryogenic vessel, and  
transportation heat loads are much greater than those of  
normal operation when the refrigerator is running.

25 If the refrigerator is switched off and not vented, a heat  
load of typically 5W is delivered into the cryogenic vessel  
by thermal conduction through the refrigerator, leading to an  
evaporation of cryogen of about 10% per day, and warming up  
the magnet coils to a quench-risk level. As it can be seen,  
30 such heat input during transportation significantly increases  
cryogen losses, and thus considerably reduces the time-to-dry  
and time-to-refill, which both are critical magnet parameters  
determining the maximum possible duration of transportation  
of the cryostat.

35

In the past, removing the refrigerator for transportation has been considered. However, this has turned out to be not practical, as it creates a risk of ice ingress, logistic problems and extra workload for installation engineers.

5

Furthermore, it has been suggested to thermally detach the refrigerator from the cryogenic vessel by removing the cryogen from the refrigerator. However, this approach is expensive, unreliable, and thermally inefficient.

10

It is therefore an object of the present invention to provide a simple and reliable technique for thermally disconnecting a refrigerator from a cryogenic vessel.

15

With the present invention, a simple and reliable technique for thermally disconnecting a refrigerator from a cryogenic vessel is provided. Time-to-dry and time-to-refill are extended. Cryogen losses are reduced for the same transportation time.

20

These and other aspects of the invention will be further elaborated on the basis of the following embodiments which are defined in the dependent claims.

25

These and other aspects of the invention will be described in detail hereinafter, by way of example, with reference to the following embodiments and the accompanying drawings; in which:

Fig. 1 shows a schematic illustration of a cryostat,

30

Fig. 2 shows a detailed illustration of the refrigerator during normal operation,

Fig. 3 shows a detailed illustration of the refrigerator during transportation.

The present invention provides a method of thermally disconnecting a cryogenic vessel, said cryogenic vessel containing a cryogen, from a refrigerator, said refrigerator being adapted for cooling said cryogen, wherein the cryogenic vessel is connected with the refrigerator by means of an input channel and an output channel, wherein the input channel and the output channel are adapted to provide a loop system for a convection circulation of cryogen through a circulation path, comprising the step of preventing any convection circulation of cryogen loop system by stopping the circulation of cryogen, thereby thermally disconnecting the refrigerator from the cryogenic vessel.

The present invention also provides a cryostat, comprising a cryogenic vessel for containing a cryogen, a refrigerator for cooling the cryogen, and an input channel and an output channel, connecting the refrigerator with the cryogenic vessel, wherein the input channel and the output channel are adapted to provide a loop system for a convection circulation of cryogen through a circulation path, further comprising means for preventing any convection circulation of cryogen through the refrigerator by stopping the circulation of cryogen, thereby thermally disconnecting the refrigerator from the cryogenic vessel.

In an embodiment of the invention, a convection path is provided by means of two separate channels connecting the refrigerator with the cryogenic vessel. Such a loop system ensures better operational conditions for the refrigerator than counter-flow through a single connecting channel, as provided in prior art designs. The proposed arrangement is considerably more efficient than the existing design during normal operation, as it creates optimised convection circulation.

The present invention also provides a method which includes thermally disconnecting the cryogenic vessel from the refrigerator by stopping the gas circulation within the loop system.

5

In a preferred embodiment of the present invention, the gas circulation in the cooling loop is stopped. The convection circulation is interrupted by thermally balancing both sides of the gas circulation loop, ensuring that the gas pressure on both sides of the input and output channels are identical when the refrigerator is switched off. For this purpose, the present invention utilizes a stratification of cryogen gas, in particular of helium gas, to thermally disconnect the refrigerator from the cryogenic vessel. According to the invention, such a stratification is automatically generated within the input and output channels when the refrigerator is not operating, as it is the case during transportation. Such stratification is known to create adequate thermal resistance to thermally detach the cryogenic vessel from the refrigerator. Thereby, thermal disconnection can be reached without removing the cryogen from the refrigerator. Because two separate connecting channels are employed, thermal disconnection can be carried out in a very reliable way, in particular, if within both channels the same stratification columns of cryogen gas are created.

According to a preferred embodiment of the invention the input channel and the output channel are arranged in a way that allows the automatic creation of a stratification column when the refrigerator is not operating. For this purpose, input channel and the output channel are arranged vertically or substantially vertically. Preferably, the channels are arranged such that an angle 'alpha' between a horizontal plane and the longitudinal axes of the channels is between 70° and 110° ( $\alpha = 90^\circ \pm 20^\circ$ ). More preferably, the

35

angle 'alpha' is between  $80^\circ$  and  $100^\circ$  ( $\alpha = 90^\circ \pm 10^\circ$ ). Even more preferably, the angle 'alpha' is between  $85^\circ$  and  $95^\circ$  ( $\alpha = 90^\circ \pm 5^\circ$ ).

5 According to a preferred embodiment of the invention the refrigerator is a two-stage refrigerator, wherein a first stage is thermally linked to a radiation shield of the cryogenic vessel, and a second stage provides cooling of the cryogen gas, e.g. by recondensing it into a liquid in an  
10 associated recondensing chamber housing a recondenser, and which is linked to the cryogenic vessel by both the input channel and the output channel.

The input channel preferably opens into the recondensing  
15 chamber at a position above the second stage of the refrigerator, while the output channel opens into the recondensing chamber at a position below the second stage of the refrigerator. By this means a very efficient convection loop is created and an effective cold exchange during normal  
20 operation is ensured.

As the pressure is defined by integral of gas density profile along the input and output channels, and density is defined by the temperature profile of the channels, identical gas  
25 pressure on the both sides of the loop at the recondensing chamber requires different lengths of channels. Therefore, according to a preferred embodiment of the invention, the input channel and the output channel are adapted in a way that the gas pressure at both sides of the channels (17, 18)  
30 is identical or substantially identical at the recondensing chamber.

In a preferred embodiment of the present invention the input channel is designed longer than the output channel and/or the  
35 input channel is thermally insulated, in order to create a

temperature profile such that the pressure on both ends is balanced and gas circulation stops automatically, if the refrigerator is non-operative, e.g. during transportation. In other words, the input and output channels, which are  
5 connecting the both sides of the loop, are adapted in a way that allows different thermal lengths of gas in the channels, ensuring no pressure difference and no gas circulation when the refrigerator is inactive.

10 Fig. 1 shows a cryostat 1 such as may be employed for holding magnet coils for an MRI (magnetic resonance imaging) system. A cryogenic vessel 2 holds a liquid cryogen 3, e.g. liquid helium. The space 4 in the cryogenic vessel 2 above the level of the liquid cryogen 3 may be filled with evaporated  
15 cryogen. The cryogenic vessel 2 is contained in a vacuum jacket 5. One or more heat shields 6 may be provided in the vacuum space between the cryogenic vessel 2 and the vacuum jacket 5. A refrigerator 7 is mounted in a refrigerator sock located in a turret 8 provided for the purpose, towards the  
20 side of the cryostat 1. Another turret with an access neck 9 is provided at the top of the cryostat 1, allowing access to the cryogenic vessel 2 from the exterior. This is used to fill the cryogenic vessel 2, to provide access for current leads and other connections to superconductive coils housed  
25 within the cryogenic vessel 2.

The refrigerator 7 is a two-stage refrigerator. The first cooling stage 11 is adapted for cooling the radiation shields 6 of the cryogenic vessel 2 via thermal couplings 12 to a  
30 first temperature, typically in the region of 80 to 100K, in order to provide a thermal insulation between the cryogenic vessel 2 and the surrounding vacuum vessel. The second cooling stage 13 is adapted for cooling the cryogen gas to a much lower temperature, typically in the region of 4 to 10 K,  
35 e.g. by cooling of heat transfer plates 14 of a recondenser

15, see also Figs. 2 and 3. In a conventional cryostat design, as depicted in Fig. 1, the refrigerator 7 is connected with the cryogenic vessel 2 by means of a single tilted tube 16. Within this tube 16 cryogen gas flows from the vessel 2 into the refrigerator 7 and at the same time liquid cryogen flows from the recondenser 15 back into the vessel 2.

According to an aspect of the invention, instead of a single connection tube 16, an input channel 17 and an output channel 18 are provided for connecting the refrigerator 7 with the cryogenic vessel 2, as seen in Figs. 2-3. Preferably, both channels 17, 18 are thin-walled, isolated pipes or tubes. Both channels 17, 18 are designed and positioned in a way to provide a convection circulation of cryogen in form of a loop system.

During the cooling process of the magnet system, cryogen gas is created above the liquid cryogen level by boiling of the liquid cryogen. Cryogen gas passes through the input channel 17 to the volume 19 within the recondensing chamber 20, at a position above the recondenser 15. For this purpose, the input channel 17 connects the space 6 in the cryogenic vessel 2 above the level of the liquid cryogen with the volume 19 within the recondensing chamber 20 above the recondenser 15.

Cryogen gas passing the heat transfer plates 14 of the recondenser 15 recondenses into liquid cryogen. The resulting liquefied cryogen then flows by gravity through the output channel 18 back to the cryogenic vessel 2. For this purpose, the output channel 18 connects the bottom region 21 of recondensing chamber 20 volume 19 with the space 6 in the cryogenic vessel 2. In Fig. 2 the cryogen gas flow through the input channel 17 is identified by arrow 22, and the backflow of the liquid cryogen through the output channel 18

is identified by arrow 23. The illustrated design employing two separate connecting channels 17, 18 results in a larger cryogenic margin of the cryostat 1.

5 Furthermore, and significantly for the present invention, the channels 17, 18 are arranged vertically or substantially vertically, such that a column of stratified cryogen gas 24 is automatically created within each channel 17, 18 when the refrigerator 7 is inoperative, as illustrated in Fig. 3. In  
10 the illustrated embodiment, the angle 'alpha' between a horizontal plane and the longitudinal axes of the channels 17, 18 is 90°. Thus, if the refrigerator 7 is switched off, and stops cooling the recondenser 15 e.g. during transportation of the cryostat 1 to an operational site,  
15 stratification of cryogen gas automatically occurs. As a result, both channels 17, 18 contain stratified cryogen gas 24. The stratification columns 24, which are symbolised in Fig. 3 by hatching, prevent any further convection circulation of cryogen through the recondensing chamber 20,  
20 past recondenser 15, thereby thermally disconnecting the recondenser 15 from the cryogenic vessel 2.

For example, the heat flow through a column 24 of stratified helium would be less than 3 mW, given a column 24 of 10 cm  
25 height and 1 cm in diameter.

The input channel 17 and the output channel 18 are preferably adapted to thermally balance both sides of the gas circulation loop in a way that the gas pressure at both sides  
30 of the channels 17, 18 is identical at the recondensing chamber 20.

The cryostat design as described above ensures an improved cold exchange during normal operation and allows an automatic  
35 thermal detaching of the refrigerator 7 from the cryogenic

vessel 2 during transportation, resulting in reduced cryogen losses.

5 In some embodiments, a further means to interrupt the circulation path is provided by means of an optional valve 25 which may be provided, to close the input channel 17 and/or the output channel 18. Preferably, the valve 25 is controlled in a way that the valve 25 automatically closes every time when the compressor of the refrigerator 7 stops.

10

It will be evident to those skilled in the art that the invention is not limited to the details of the foregoing illustrative embodiments, and that the present invention may be embodied in other specific forms without departing from  
15 the scope of the invention as defined in the appended claims.

## Reference numerals

	1	cryostat
5	2	cryogenic vessel
	3	liquid cryogen
	4	space above liquid level
	5	vacuum jacket
	6	heat shield
10	7	refrigerator 8 turret
	9	access neck
	10	(free)
	11	first cooling stage
	12	coupling
15	13	second cooling stage
	14	heat transfer plate
	15	recondenser
	16	connecting tube
	17	input channel
20	18	output channel
	19	volume in recondensing chamber
	20	recondensing chamber
	21	bottom region of recondenser
	22	gas flow
25	23	liquid backflow
	24	column of stratified cryogen gas
	25	valve
	26	entrance
	27	exit

30

## CLAIMS:

1. A method of thermally disconnecting a cryogenic vessel (2) from a refrigerator (7), said cryogenic vessel (2) containing a cryogen (3), said refrigerator (7) being adapted for cooling said cryogen (3) by cooling a recondenser (15) within a recondensing chamber (20),  
wherein the cryogenic vessel (2) is connected with the recondensing chamber (20) by means of an input channel (17) and an output channel (18), wherein the input channel (17) and the output channel (18) are adapted to provide a loop system for a convection circulation of cryogen through a circulation path which passes through the recondensing chamber (20), wherein the input channel (17) and the output channel (18) are arranged vertically or substantially vertically,  
the method comprising the step of preventing any convection circulation of cryogen through the recondensing chamber (20) by stopping the circulation of cryogen, thereby thermally disconnecting the refrigerator (7) from the cryogenic vessel (2),  
wherein the circulation of cryogen is stopped by means of a column (24) of stratified cryogen gas, which column (24) is automatically created within each channel (17, 18) when the refrigerator (7) is not operating.

2. The method of thermally disconnecting a cryogenic vessel (2) as claimed in claim 1, wherein the circulation of cryogen is further prevented by closing a valve (25) which interrupts the circulation path.

3. The method of thermally disconnecting a cryogenic vessel (2) as claimed in claim 2, wherein the valve (25) is closed automatically when the refrigerator (7) is not operating.

4. A cryostat (1), comprising a cryogenic vessel (2) for containing a cryogen (3), a refrigerator (7) for cooling the cryogen (3) by cooling a recondenser (15) within a recondensing chamber (20), and an input channel (17) and an output channel (18), connecting the recondensing chamber (20) with the cryogenic vessel (2),  
5 wherein the input channel (17) and the output channel (18) provide a loop system for a convection circulation of cryogen through a circulation path which passes through the recondensing chamber (20), wherein the input channel (17) and the output channel (18) are arranged vertically or substantially vertically.

5. A cryostat (1) according to claim 4, wherein, in case of the refrigerator (7) not operating, a column (24) of stratified cryogen gas is automatically created within each channel (17, 18), said column (24) of stratified cryogen gas preventing convection circulation of cryogen through the recondensing chamber (20), thereby thermally disconnecting the refrigerator (7) from the cryogenic vessel (2).  
15  
20

6. The cryostat as claimed in claim 4, further comprising a valve (25) adapted to interrupt the circulation path.

7. The cryostat (1) as claimed in one of claims 4 to 6, wherein the refrigerator (7) is a two-stage refrigerator, and the input channel (17) connects the recondensing chamber (20) above the second stage (15) of the refrigerator (7) with the cryogenic vessel (2), and the output channel (18) connects the recondensing chamber (20) below the second stage (15) of the refrigerator (7) with the cryogenic vessel (2).  
25  
30

8. The cryostat (1) as claimed in one of claims 4 to 8, wherein the input channel (17) and the output channel (18) are adapted in a way that the gas pressure at both sides of  
35

the channels (17, 18) is identical or substantially identical with the refrigerator (7) inoperative.

FIG 1

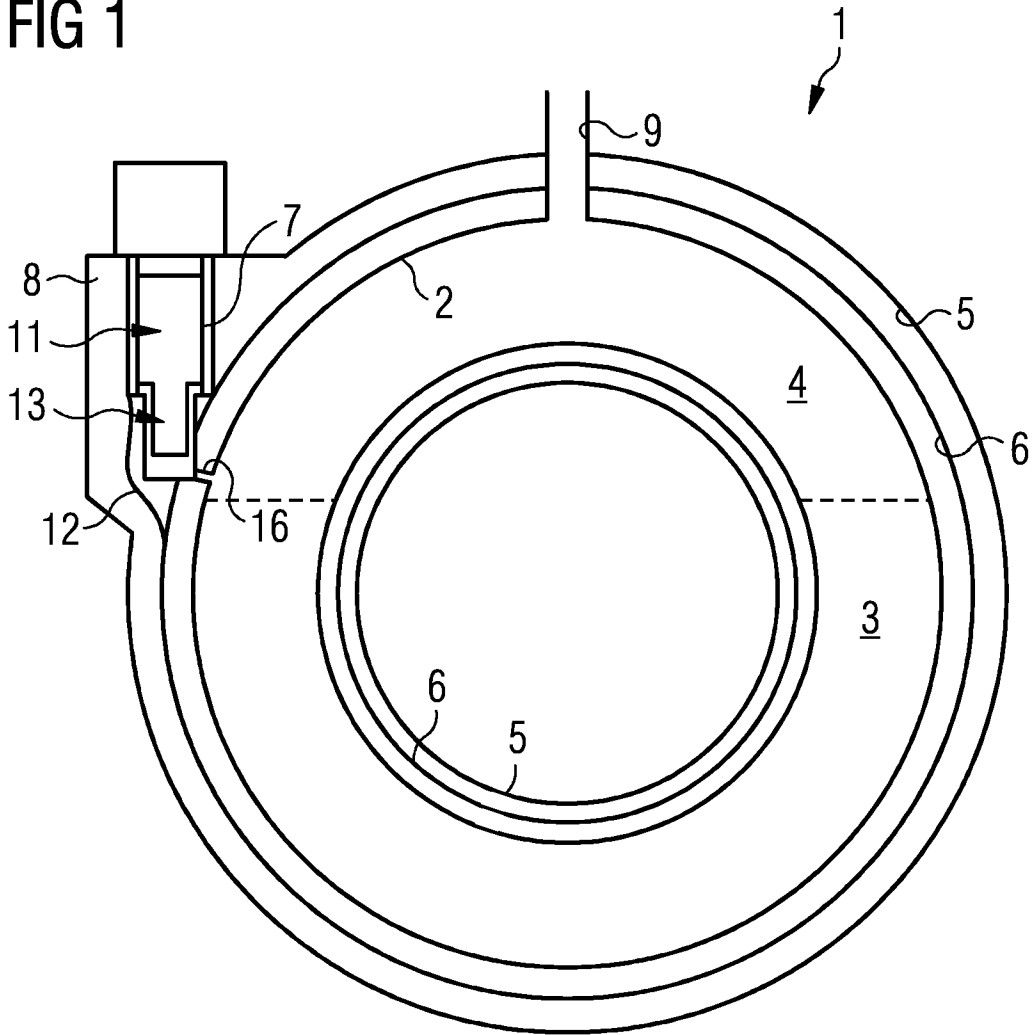

FIG 2

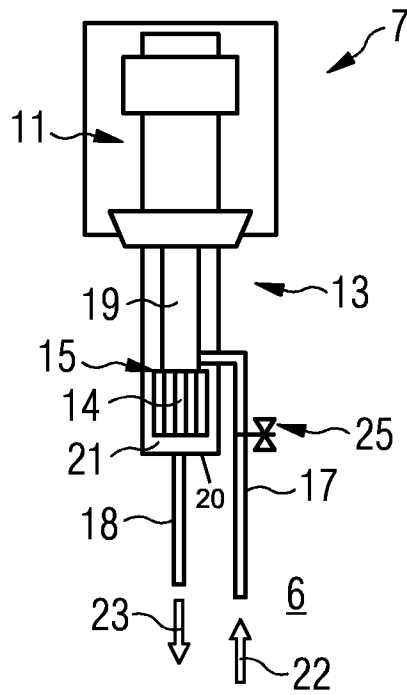
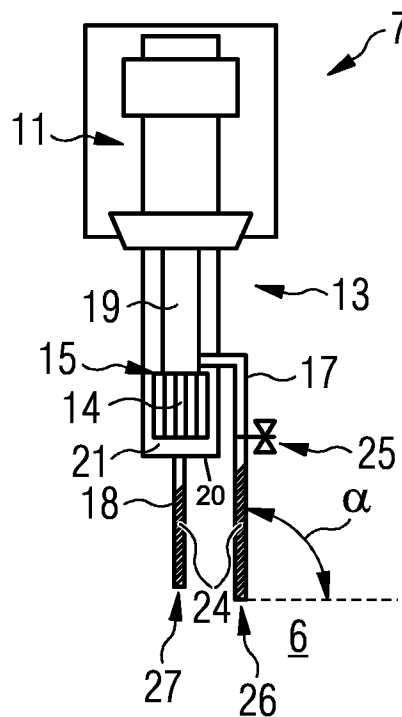

FIG 3



**INTERNATIONAL SEARCH REPORT**

International application No  
PCT/EP2015/054945

A. CLASSIFICATION OF SUBJECT MATTER  
 INV. F25B9/10 F25D19/00 F25B9/14  
 ADD.  
 According to International Patent Classification (IPC) or to both national classification and IPC

B. FIELDS SEARCHED  
 Minimum documentation searched (classification system followed by classification symbols)  
 F25B F25D

Documentation searched other than minimum documentation to the extent that such documents are included in the fields searched

Electronic data base consulted during the international search (name of data base and, where practicable, search terms used)  
 EPO-Internal, WPI Data

C. DOCUMENTS CONSIDERED TO BE RELEVANT

Category*	Citation of document, with indication, where appropriate, of the relevant passages	Relevant to claim No.
X	US 2009/049863 A1 (WANG CHAO [US]) 26 February 2009 (2009-02-26) the whole document -----	1-8
X	EP 1 760 480 A1 (BRUKER BIOSPIN AG [CH]) 7 March 2007 (2007-03-07) the whole document -----	1-8
A	US 5 936 499 A (ECKELS PHILLIP WILLIAM [US]) 10 August 1999 (1999-08-10) the whole document -----	1-8
A	US 2012/167598 A1 (DIEDERICHS JOST [US] ET AL) 5 July 2012 (2012-07-05) the whole document -----	1-8

Further documents are listed in the continuation of Box C.

See patent family annex.

\* Special categories of cited documents :

"A" document defining the general state of the art which is not considered to be of particular relevance	"T" later document published after the international filing date or priority date and not in conflict with the application but cited to understand the principle or theory underlying the invention
"E" earlier application or patent but published on or after the international filing date	"X" document of particular relevance; the claimed invention cannot be considered novel or cannot be considered to involve an inventive step when the document is taken alone
"L" document which may throw doubts on priority claim(s) or which is cited to establish the publication date of another citation or other special reason (as specified)	"Y" document of particular relevance; the claimed invention cannot be considered to involve an inventive step when the document is combined with one or more other such documents, such combination being obvious to a person skilled in the art
"O" document referring to an oral disclosure, use, exhibition or other means	"&" document member of the same patent family
"P" document published prior to the international filing date but later than the priority date claimed	

Date of the actual completion of the international search  18 June 2015	Date of mailing of the international search report  26/06/2015
---	--

Name and mailing address of the ISA/ European Patent Office, P.B. 5818 Patentlaan 2 NL - 2280 HV Rijswijk Tel. (+31-70) 340-2040, Fax: (+31-70) 340-3016	Authorized officer  Lucic, Anita
--	--

# INTERNATIONAL SEARCH REPORT

Information on patent family members

International application No PCT/EP2015/054945
---

Patent document cited in search report	Publication date	Patent family member(s)	Publication date
US 2009049863	A1	26-02-2009	NONE
-----			
EP 1760480	A1	07-03-2007	DE 102005041383 A1 22-03-2007
			EP 1760480 A1 07-03-2007
			JP 4336359 B2 30-09-2009
			JP 2007064984 A 15-03-2007
			US 2007107445 A1 17-05-2007
-----			
US 5936499	A	10-08-1999	DE 69929494 T2 14-09-2006
			EP 0937995 A2 25-08-1999
			JP 4960539 B2 27-06-2012
			JP H11317307 A 16-11-1999
			US 5936499 A 10-08-1999
-----			
US 2012167598	A1	05-07-2012	US 2012167598 A1 05-07-2012
			WO 2013043248 A1 28-03-2013
-----			