

O. O. STORLE.  
Knot-Tier for Grain-Binders.

No. 220,551.

Patented Oct. 14, 1879.

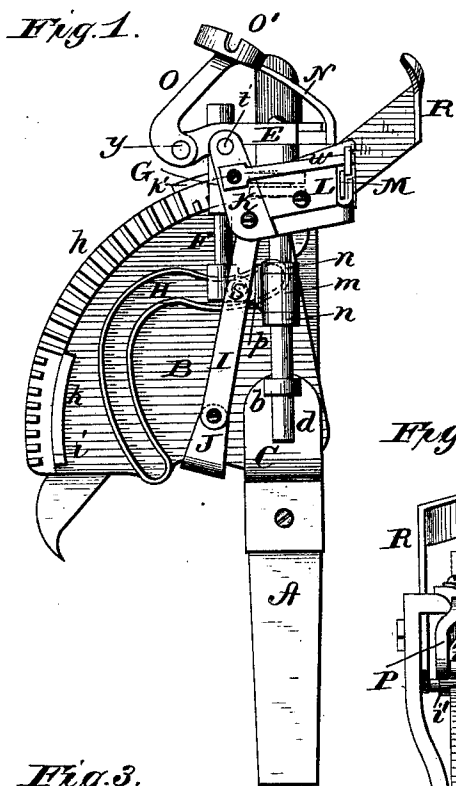

Fig. 11.

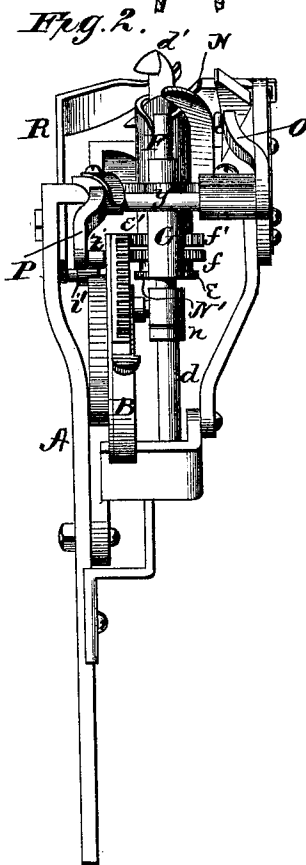
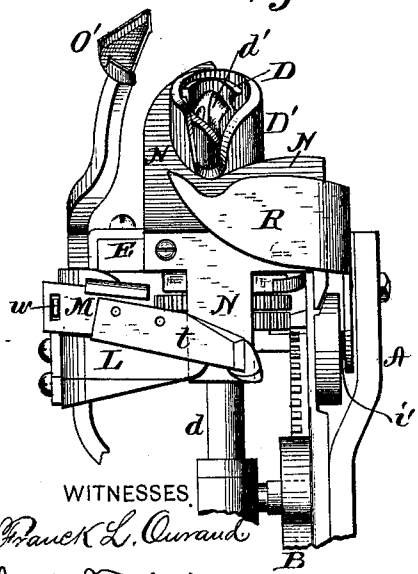

Fig. 3.



WITNESSES.

Francis L. Curran  
H. A. Toulmin.

INVENTOR

O. O. Storle

per S. S. Stout

ATTORNEY

O. O. STORLE.  
Knot-Tier for Grain-Binders.

No. 220,551.

Patented Oct. 14, 1879.

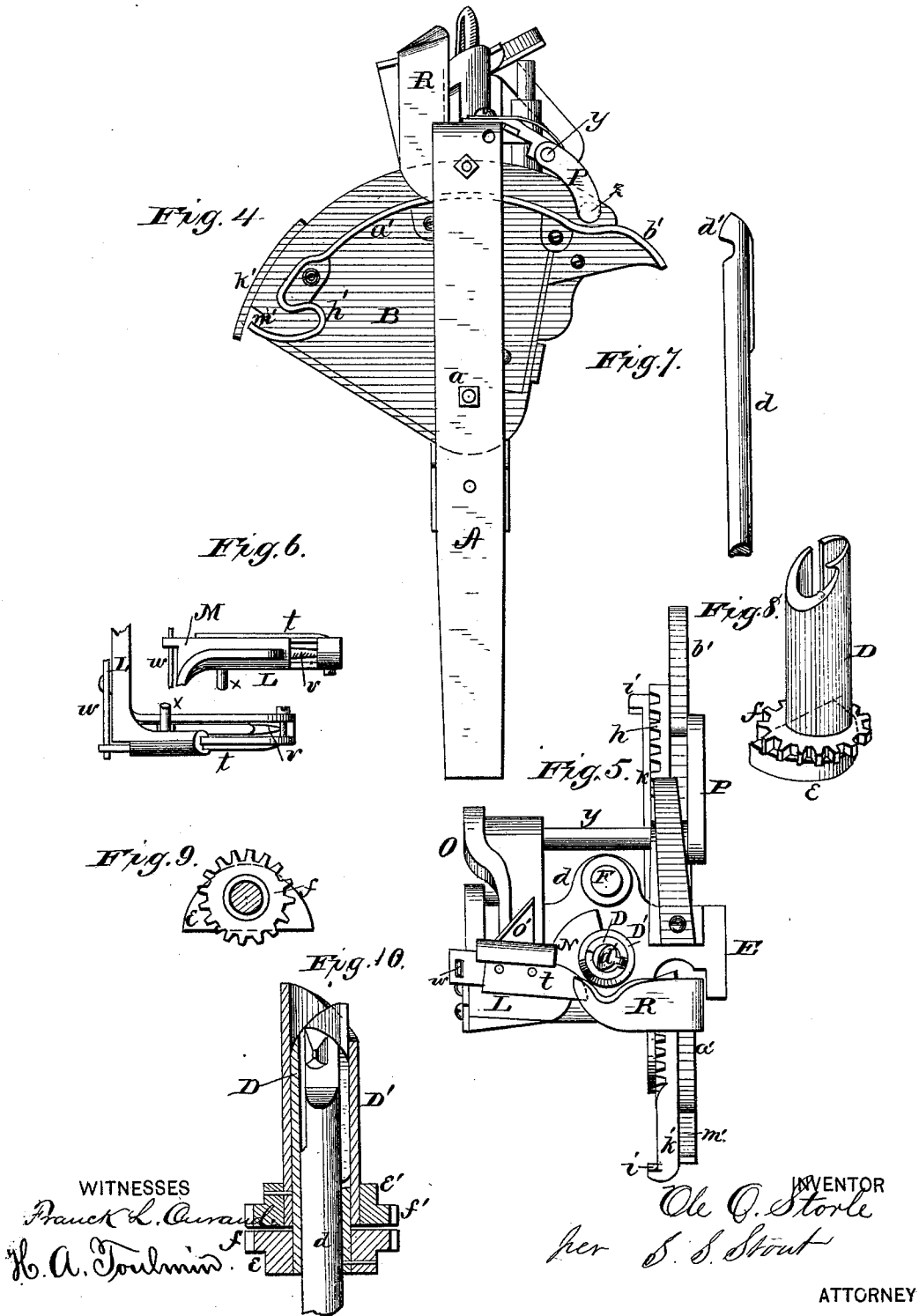

WITNESSES

Frank L. Curran  
H. A. Toulmin

INVENTOR

O. O. Storle  
per S. S. Stout

ATTORNEY

# UNITED STATES PATENT OFFICE.

OLE O. STORLE, OF MILWAUKEE, WISCONSIN, ASSIGNOR OF TWO-THIRDS OF HIS RIGHT TO J. G. FLINT, JR., OF SAME PLACE.

## • IMPROVEMENT IN KNOT-TIERS FOR GRAIN-BINDERS.

Specification forming part of Letters Patent No. **220,551**, dated October 14, 1879; application filed May 24, 1879.

*To all whom it may concern:*

Be it known that I, OLE O. STORLE, of Milwaukee, in the county of Milwaukee, and in the State of Wisconsin, have invented a new and useful Improvement in Knot-Tiers for Grain-Binders; and do hereby declare that the following is a full, clear, and exact description thereof.

My invention relates to grain-binders, and more particularly to the mechanism for tying the knot; and it consists in the construction and arrangement of devices whereby the ends of the cord which is made to encircle the bundle of grain are drawn together and tied, as will be hereinafter more fully set forth.

In order to enable others skilled in the art to which my invention appertains to make and use the same, I will now proceed to describe its construction and operation, referring to the annexed drawings, which form a part of this specification, and in which—

Figure 1 is a side elevation of my device. Figs. 2 and 3 are edge views of the same. Fig. 4 is a side elevation from the opposite side to that shown in Fig. 1. Fig. 5 is a plan view. Figs. 6, 7, 8, 9, and 10 are detailed views of parts of the machine. Fig. 11 shows the knot tied by the machine.

A represents the standard or frame to which all the operating parts are connected, and which is to be firmly secured in any suitable or convenient manner to the main frame of the binder. To this standard, at *a*, is pivoted a segment, B, by which the mechanism for tying is operated. Below the pivot-point to the standard A is attached a bracket, C, to which is attached a loop or eye, *b*, and through this eye passes the lower end of a vertical shaft, *d*. This shaft passes upward through two concentric tubes, D D', which are journaled in a head, E, attached to or formed on the upper end of the standard or frame A. The inside tube, D, is at or near its lower end provided with a pinion, *f*, which has on its lower side a triangular piece, *e*, called a "delay." The lower end of the outside tube, D', is in like manner provided with pinion *f'*, having on its

upper face a delay, *e'*. The pinion *f'* is located immediately above the pinion *f*.

The upper end of the shaft *d* is formed with a hook, *d'*, and said shaft is feathered in the interior tube, D, so as to revolve at all times therewith, and yet be capable of an up-and-down movement. This feather also prevents the cord from wedging down at the side of the hook between it and the tube D.

The pinions *f f'* engage with a rack, *h*, on the side of the segment B, and which rack meshes with said pinions for about one-half of its length (more or less) in the center. At each end the rack is cut away one-half in width for about one-fourth of its length. At one end this is done at the top and at the other end at the bottom of the rack. Corresponding with these reduced portions of the rack, delay-surfaces *k k'* are formed beyond the inner and outer peripheries of the rack, as shown, and the outer end of each delay-surface forms a stop, *i*.

On the shaft or spindle *d* are secured two collars, *n n*, between which is fitted a tube, *m*, formed with a bar or web, *p*, connecting it with a vertical rod, F, which passes upward through a tubular bearing, G, on the head E, parallel with the shaft or spindle *d*.

From the connecting bar or web *p* projects a stud with roller *s*, which works in an eccentric guide, H, on the face of the segment B. To the face of the segment is further attached a bracket, J, to which is pivoted an arm, I, for operating the mechanism for holding both portions of the looped cord after it has passed around the bundle of grain, and during the tying process.

This mechanism consists of an arm, K, pivoted at *t'* to the head E, and having a bent arm, L, attached to its outer end, the arm I being pivoted to said arm K at its end, as shown. The outer portion of the arm L projects over and at right angles to the segment B, and is constructed to form a guide for a plate, M, to which the cutter *t* is secured. A pin, *v*, also projects from said plate or slide M, below the cutter, and a spring, *w*, is arranged

at the end of the plate for holding the same with the cutter and pin inward in position.

Another pin, *x*, projects downward from the plate M, for a purpose that will be hereinafter described.

To the head E is attached a shield, N, which partially encircles the upper end of the tube D' and forms a guide for the loop. This shield is inclined, as shown, and is attached to the head by means of an elbow, which projects down and passes around the shaft *d*, forming a bearing, N', for the delay *e* to revolve in.

At one side of the head is a rock-shaft, *y*, which has on one end an arm, O, projecting in the direction of the cord-holding mechanism above described, and which carries at its end the arm O'. At the other end of the rock-shaft *y* is another arm, P, projecting in the opposite direction, and provided at its end with a stud and roller, *z*, which supports said arm upon a guide, *a'*, on the back of the segment B. This guide terminates at one end in a raised surface, *b'*, and at the other end in a hooked or depressed surface, *h'*. This hook or depression operates a finger, R, pivoted eccentrically to the standard, and provided with a stud and roller, *i'*, on which said hook takes.

The operation of my machine is substantially as follows:

The frame or standard A being securely fastened to the binder-frame in a perpendicular position, suitable mechanical means are employed to give the segment B, which operates the various devices in the knot-tier, a reciprocating movement. By preference I employ a crank on some revolving shaft in the reaper or binder proper, coupled to the segment by means of a connecting-rod. When the point *m'* is at its point of nearest approach to the center of the standard A the machine is in position to engage the cord thrown over and around the bundle. The end of the cord, before it is looped around the bundle, is securely held by the pin *v* in the cord-holder. The cord is looped about the bundle by means of an arm similar to that employed in the ordinary well-known binder. As the cord is carried down after encircling the bundle it is brought near to and past the holder and between the finger R and the tier. The finger is now thrown forward by the stud and roller *i'*, passing out of the depression *h'* and onto the track *a'*, and presses both parts of the cord into the notches or jaws of the two tubes D D', where they are securely held. By the peculiar system of gears and delays the inside tube, D, is made first to rotate, while the outside tube, D', is at rest, until the cord is securely bit or held between the sides of the two notched tubes, when they are both moved simultaneously by means of the gears *f f'* on the rack *h*. During this part of the movement of the segment the spindle *d* is moved upward by means of the eccentric guide H on the segment, and the cord-holder is turned upward close under the finger R. As the fast-held cord is carried about the spindle it forms a

loop-plate, N, and the incline on tube D' guiding the parts of the cord near to the cord-holder over the looped or wound part into the hook *d'* on the spindle. As the segment continues to advance the spindle continues to descend and draws the cord from above the loop down through it, and the inner tube, D, is stopped by its delay, while the outer tube, D', continues to rotate, whereby the cord previously grasped is gradually released, and the continuously descending movement of the spindle draws the knot tight, since the tube D holds the looped cord from following it; and at the same time the cutting device is operated by the cam O', and the end of the cord is grasped and held by the pin *v* to enable the binder-arm to bring the cord around a new bundle and the operation repeated. When the knot is tied or fully formed the loop is easily slipped over the end of the spindle by the falling bundle. The return movement of the segment B carries all the parts back to their original positions.

It will be noticed that the cord is clamped at two points; that the loop is formed from that portion of the cord held between the two clamps and around the inner clamp or that next to the gavel, and that the cord is drawn through the loop to form the knot before the inner clamp releases the cord, so that the slack of the knot or loop is not allowed to go into the bundle or that portion of the cord around the gavel, but is taken up outside the knot in the loop of the cord which is pulled through the loop first formed by the hook or spindle.

The cutting device is operated at the proper time by the roller *z*, riding upon the raised surface *b'* at the end of the track *a'*, which throws the arm O forward, so that the front portion of the cam O', striking the pin *x*, will move back the slide M, with the cutter *t* and cord-holding pin *v*. As soon as the front portion of said cam has passed the pin *x* the rear portion of the cam operates against the same pin to throw the slide M inward, causing the cutter to sever the cord and the pin *v* to take hold of the end of the cord from the spool, the spring *w* simply holding the parts in proper position.

Having thus fully described my invention, what I claim as new, and desire to secure by Letters Patent, is—

1. In a binder, the combination of a clamping mechanism adapted to clamp the cord at two points, a looping mechanism adapted to form a loop from that portion of the cord held between the two clamps, the loop being formed around the inner clamp or next to the gavel, and a device adapted to draw the cord through the loop and form the knot before the clamp next the gavel releases the cord, substantially as described.

2. In a grain-binder, a combined clamp and looping mechanism consisting of two concentric cylinders or tubes, with gear mechanism adapted to impart both simultaneous and in-

dependent rotary motion thereto, and a guide or shield, the devices combined substantially in the manner and for the purpose specified.

3. A knot-tier for grain-binders, consisting of an outer tube, D', and an inner tube, D, constructed as described, which clamp the cord or twine between them, and a hook to draw the bow through to form the knot, as set forth.

4. The combination of the inner tube, D, and the outer tube, D', having both simultaneous and independent rotary motion, and the spindle *d*, rotating with the inner tube, and movable up and down therein, substantially as herein set forth.

5. The combination of the tubes D D', constructed as described, gears *f f'*, with delays *e e'*, and the reciprocating segment B, provided with the rack *h*, cut away at its ends, and provided with the delay-surfaces *k k'*, substantially as and for the purposes herein set forth.

6. The finger R, operated by means of the stud and roller *i*, and the segment B, with track *a'* and hook *h'*, in combination with the tubes D D', for the purposes herein set forth.

7. The combination of the segment B, bracket J, arm and cord-holder K L, as and for the purpose herein set forth.

8. The slide M, arranged in the arm L, and provided with the cutter *t*, holding-pin *v*, and pin *x*, in combination with the double cam O', substantially as and for the purposes herein set forth.

9. The combination of the cam O', arm O, rocking shaft *y*, arm P, with stud and roller *z*, and the segment B, having track *a'*, with raised surface *b'*, substantially as and for the purposes herein set forth.

10. The combination of the spindle *d*, with collars *n n*, tube *m*, with web *p*, guide-rod F, stud and roller *s*, and the eccentric guide H on the segment B, substantially as and for the purposes herein set forth.

In testimony that I claim the foregoing I have hereunto set my hand.

OLE O. STORLE.

Witnesses:

E. G. ASMUS,  
STANLEY S. STOUT.