

(19) World Intellectual Property Organization  
International Bureau



(43) International Publication Date  
29 March 2012 (29.03.2012)

(10) International Publication Number  
**WO 2012/040438 A1**

(51) International Patent Classification:  
A61B 18/14 (2006.01)

(21) International Application Number:  
PCT/US2011/052723

(22) International Filing Date:  
22 September 2011 (22.09.2011)

(25) Filing Language: English

(26) Publication Language: English

(30) Priority Data:  
61/386,117 24 September 2010 (24.09.2010) US

(71) Applicant (for all designated States except US):  
ETHICON ENDO-SURGERY, INC. [US/US]; 4545  
Creek Road, Cincinnati, OH 45242 (US).

(72) Inventors; and

(75) Inventors/Applicants (for US only): **WORRELL, Barry, C.** [US/US]; 1647 Lago Mar Drive, Centerville, OH 45458 (US). **NORVELL, David, K.** [US/US]; 570 Doverdale Drive, Monroe, OH 45050 (US). **SCHEIB, Charles, J.** [US/US]; 11329 Donwiddle Drive, Loveland, OH 45140 (US). **SHELTON, Frederick, E., IV** [US/US]; 245 East Main Street, Hillsboro, OH 45153 (US). **STROBL, Geoffrey, S.** [US/US]; 15993 Colonial Drive, Williamsburg, OH 45176 (US). **SWAYZE, Jeffrey, S.** [US/US]; 7047 Birchley Drive, Hamilton, OH 45011 (US). **TREES, Gregory, A.** [US/US]; 9265 Hickory Hill Court, Loveland, OH 45140 (US). **ZERKLE, Jason, E.** [US/US]; 755 Macedonia Road, Blanchester, OH

45107 (US). **MONTGOMERY, Kevin, M.** [US/US]; Kevin M. Montgomery, 12031 Cedar creek Drive, Cincinnati, OH 45240 (US).

(74) Agents: **JOHNSON, Philip, S.** et al.; Johnson & Johnson, 1 Johnson & Johnson Plaza, New Brunswick, NJ 08933 (US).

(81) Designated States (unless otherwise indicated, for every kind of national protection available): AE, AG, AL, AM, AO, AT, AU, AZ, BA, BB, BG, BH, BR, BW, BY, BZ, CA, CH, CL, CN, CO, CR, CU, CZ, DE, DK, DM, DO, DZ, EC, EE, EG, ES, FI, GB, GD, GE, GH, GM, GT, HN, HR, HU, ID, IL, IN, IS, JP, KE, KG, KM, KN, KP, KR, KZ, LA, LC, LK, LR, LS, LT, LU, LY, MA, MD, ME, MG, MK, MN, MW, MX, MY, MZ, NA, NG, NI, NO, NZ, OM, PE, PG, PH, PL, PT, QA, RO, RS, RU, RW, SC, SD, SE, SG, SK, SL, SM, ST, SV, SY, TH, TJ, TM, TN, TR, TT, TZ, UA, UG, US, UZ, VC, VN, ZA, ZM, ZW.

(84) Designated States (unless otherwise indicated, for every kind of regional protection available): ARIPO (BW, GH, GM, KE, LR, LS, MW, MZ, NA, SD, SL, SZ, TZ, UG, ZM, ZW), Eurasian (AM, AZ, BY, KG, KZ, MD, RU, TJ, TM), European (AL, AT, BE, BG, CH, CY, CZ, DE, DK, EE, ES, FI, FR, GB, GR, HR, HU, IE, IS, IT, LT, LU, LV, MC, MK, MT, NL, NO, PL, PT, RO, RS, SE, SI, SK, SM, TR), OAPI (BF, BJ, CF, CG, CI, CM, GA, GN, GQ, GW, ML, MR, NE, SN, TD, TG).

**Declarations under Rule 4.17:**

— as to the identity of the inventor (Rule 4.17(i))

[Continued on next page]

(54) Title: ARTICULATION JOINT FEATURES FOR ARTICULATING SURGICAL DEVICE

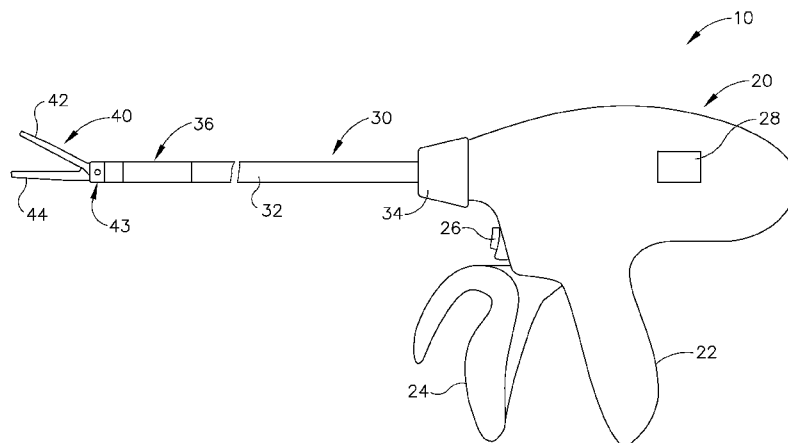

Fig.1

(57) Abstract: An electrosurgical device comprises a body, an end effector, a cutting member, and a shaft. The end effector includes a pair of jaws that are operable to deliver RF energy to tissue that is clamped between the jaws. The cutting member is operable to sever tissue that is clamped between the jaws. The shaft extends between the body and the end effector. The shaft includes an articulation section that is operable to selectively position the end effector at non-parallel positions relative to the longitudinal axis of the shaft. Some versions include a rotation section that is distal to the articulation section. The rotation section is operable to rotate the end effector relative to the articulation section.



WO 2012/040438 A1

- *as to applicant's entitlement to apply for and be granted a patent (Rule 4.17(ii))*
  - *as to the applicant's entitlement to claim the priority of the earlier application (Rule 4.17(iii))*
- Published:**
- *with international search report (Art. 21(3))*
  - *before the expiration of the time limit for amending the claims and to be republished in the event of receipt of amendments (Rule 48.2(h))*

## ARTICULATION JOINT FEATURES FOR ARTICULATING SURGICAL DEVICE

Barry C. Worrell  
David K. Norvell  
Charles J. Scheib  
Frederick E. Shelton, IV  
Geoffrey S. Strobl  
Jeffrey S. Swayze  
Gregory A. Trees  
Jason E. Zerkle  
Kevin M. Montgomery

## PRIORITY

**[0001]** This application claims priority to U.S. Provisional Application Serial No. 61/386,117, filed September 24, 2010, entitled "Articulating Surgical Device," the disclosure of which is incorporated by reference herein.

## BACKGROUND

**[0002]** A variety of surgical instruments include a tissue cutting element and one or more elements that transmit RF energy to tissue (e.g., to coagulate or seal the tissue). An example of such a device is the ENSEAL® Tissue Sealing Device by Ethicon Endo-Surgery, Inc., of Cincinnati, Ohio. Further examples of such devices and related concepts are disclosed in U.S. Pat. No. 6,500,176 entitled "Electrosurgical Systems and Techniques for Sealing Tissue," issued December 31, 2002, the disclosure of which is incorporated by reference herein; U.S. Pat. No. 7,112,201 entitled "Electrosurgical Instrument and Method of Use," issued September 26, 2006, the disclosure of which is incorporated by reference herein; U.S. Pat. No. 7,125,409, entitled "Electrosurgical Working End for Controlled Energy Delivery," issued October 24, 2006, the disclosure of which is incorporated by reference herein; U.S. Pat. No. 7,169,146 entitled "Electrosurgical Probe and Method of Use," issued January 30, 2007, the disclosure of which is incorporated by reference herein; U.S. Pat. No. 7,186,253, entitled

“Electrosurgical Jaw Structure for Controlled Energy Delivery,” issued March 6, 2007, the disclosure of which is incorporated by reference herein; U.S. Pat. No. 7,189,233, entitled “Electrosurgical Instrument,” issued March 13, 2007, the disclosure of which is incorporated by reference herein; U.S. Pat. No. 7,220,951, entitled “Surgical Sealing Surfaces and Methods of Use,” issued May 22, 2007, the disclosure of which is incorporated by reference herein; U.S. Pat. No. 7,309,849, entitled “Polymer Compositions Exhibiting a PTC Property and Methods of Fabrication,” issued December 18, 2007, the disclosure of which is incorporated by reference herein; U.S. Pat. No. 7,311,709, entitled “Electrosurgical Instrument and Method of Use,” issued December 25, 2007, the disclosure of which is incorporated by reference herein; U.S. Pat. No. 7,354,440, entitled “Electrosurgical Instrument and Method of Use,” issued April 8, 2008, the disclosure of which is incorporated by reference herein; U.S. Pat. No. 7,381,209, entitled “Electrosurgical Instrument,” issued June 3, 2008, the disclosure of which is incorporated by reference herein; U.S. Pub. No. 2011/0087218, entitled “Surgical Instrument Comprising First and Second Drive Systems Actuable by a Common Trigger Mechanism,” published April 14, 2011, the disclosure of which is incorporated by reference herein; and U.S. Pat. App. No. 13/151,181, entitled “Motor Driven Electrosurgical Device with Mechanical and Electrical Feedback,” filed June 2, 2011, the disclosure of which is incorporated by reference herein.

**[0003]** In addition, a variety of surgical instruments include a shaft having an articulation section, providing enhanced positioning capabilities for an end effector that is located distal to the articulation section of the shaft. Examples of such devices include various models of the ENDOPATH® endocutters by Ethicon Endo-Surgery, Inc., of Cincinnati, Ohio. Further examples of such devices and related concepts are disclosed in U.S. Pat. No. 7,380,696, entitled “Articulating Surgical Stapling Instrument Incorporating a Two-Piece E-Beam Firing Mechanism,” issued June 3, 2008, the disclosure of which is incorporated by reference herein; U.S. Pat. No. 7,404,508, entitled “Surgical Stapling and Cutting Device,” issued July 29, 2008, the disclosure of which is incorporated by reference herein; U.S. Pat. No. 7,455,208, entitled “Surgical Instrument with Articulating Shaft with Rigid Firing Bar Supports,” issued November 25, 2008, the disclosure of which is incorporated by reference herein; U.S. Pat. No. 7,506,790, entitled “Surgical

Instrument Incorporating an Electrically Actuated Articulation Mechanism,” issued March 24, 2009, the disclosure of which is incorporated by reference herein; U.S. Pat. No. 7,549,564, entitled “Surgical Stapling Instrument with an Articulating End Effector,” issued June 23, 2009, the disclosure of which is incorporated by reference herein; U.S. Pat. No. 7,559,450, entitled “Surgical Instrument Incorporating a Fluid Transfer Controlled Articulation Mechanism,” issued July 14, 2009, the disclosure of which is incorporated by reference herein; U.S. Pat. No. 7,654,431, entitled “Surgical Instrument with Guided Laterally Moving Articulation Member,” issued February 2, 2010, the disclosure of which is incorporated by reference herein; U.S. Pat. No. 7,780,054, entitled “Surgical Instrument with Laterally Moved Shaft Actuator Coupled to Pivoting Articulation Joint,” issued August 24, 2010, the disclosure of which is incorporated by reference herein; U.S. Pat. No. 7,784,662, entitled “Surgical Instrument with Articulating Shaft with Single Pivot Closure and Double Pivot Frame Ground,” issued August 31, 2010, the disclosure of which is incorporated by reference herein; and U.S. Pat. No. 7,798,386, entitled “Surgical Instrument Articulation Joint Cover,” issued September 21, 2010, the disclosure of which is incorporated by reference herein.

**[0004]** While several medical devices have been made and used, it is believed that no one prior to the inventors has made or used the invention described in the appended claims.

#### BRIEF DESCRIPTION OF THE DRAWINGS

**[0005]** While the specification concludes with claims which particularly point out and distinctly claim this technology, it is believed this technology will be better understood from the following description of certain examples taken in conjunction with the accompanying drawings, in which like reference numerals identify the same elements and in which:

**[0006]** FIG. 1 depicts a side elevational view of an exemplary electrosurgical medical device;

**[0007]** FIG. 2 depicts a perspective view of the end effector of the device of FIG. 1, in an open configuration;

- [0008] FIG. 3 depicts another perspective view of the end effector of the device of FIG. 1, in an open configuration;
- [0009] FIG. 4 depicts a cross-sectional end view of the end effector of FIG. 2, in a closed configuration and with the blade in a distal position;
- [00010] FIG. 5 depicts a perspective view of an exemplary articulation section for the shaft of the device of FIG.1;
- [00011] FIG. 6 depicts a cross-sectional end view of the articulation section of FIG. 5, taken along line 6-6 of FIG. 5;
- [00012] FIG. 7 depicts a top perspective view of another exemplary articulation section for the shaft of the device of FIG. 1;
- [00013] FIG. 8 depicts a bottom perspective view of another the articulation section of FIG. 7;
- [00014] FIG. 9 depicts a top plan view of the articulation section of FIG. 7;
- [00015] FIG. 10 depicts a perspective view of another exemplary articulation section for the shaft of the device of FIG. 1;
- [00016] FIG. 11 depicts an exploded view of the articulation section of FIG. 10;
- [00017] FIG. 12 depicts an exploded view of another articulation section for the shaft of the device of FIG. 1;
- [00018] FIG. 13 depicts a plan view of the articulation section of FIG. 12;
- [00019] FIG. 14 depicts a perspective view of another exemplary articulation section for the shaft of the device of FIG. 1;
- [00020] FIG. 15 depicts a perspective view of a bead component of the articulation section of FIG. 14;
- [00021] FIG. 16 depicts a top plan view of the bead component of FIG. 15;
- [00022] FIG. 17 depicts a cross-sectional side view of the articulation section of FIG. 14;

- [00023] FIG. 18 depicts a partial perspective view of distal end portions of the articulation section of FIG. 14;
- [00024] FIG. 19 depicts a partial perspective view of an upper portion of a distal rotation feature associated with the articulation section of FIG. 14; and
- [00025] FIG. 20 depicts a partial perspective view of a lower portion of the distal rotation feature of FIG. 19.
- [00026] The drawings are not intended to be limiting in any way, and it is contemplated that various embodiments of the technology may be carried out in a variety of other ways, including those not necessarily depicted in the drawings. The accompanying drawings incorporated in and forming a part of the specification illustrate several aspects of the present technology, and together with the description serve to explain the principles of the technology; it being understood, however, that this technology is not limited to the precise arrangements shown.

#### DETAILED DESCRIPTION

- [00027] The following description of certain examples of the technology should not be used to limit its scope. Other examples, features, aspects, embodiments, and advantages of the technology will become apparent to those skilled in the art from the following description, which is by way of illustration, one of the best modes contemplated for carrying out the technology. As will be realized, the technology described herein is capable of other different and obvious aspects, all without departing from the technology. Accordingly, the drawings and descriptions should be regarded as illustrative in nature and not restrictive.
- [00028] It is further understood that any one or more of the teachings, expressions, embodiments, examples, etc. described herein may be combined with any one or more of the other teachings, expressions, embodiments, examples, etc. that are described herein. The following-described teachings, expressions, embodiments, examples, etc. should therefore not be viewed in isolation relative to each other. Various suitable ways in which the teachings herein may be combined will be readily apparent to those of ordinary

skill in the art in view of the teachings herein. Such modifications and variations are intended to be included within the scope of the claims.

**[00029]** I. Exemplary Electrosurgical Device with Articulation Feature

**[00030]** FIGS. 1-4 show an exemplary electrosurgical instrument (10) that is constructed and operable in accordance with at least some of the teachings of U.S. Pat. No. 6,500,176; U.S. Pat. No. 7,112,201; U.S. Pat. No. 7,125,409; U.S. Pat. No. 7,169,146; U.S. Pat. No. 7,186,253; U.S. Pat. No. 7,189,233; U.S. Pat. No. 7,220,951; U.S. Pat. No. 7,309,849; U.S. Pat. No. 7,311,709; U.S. Pat. No. 7,354,440; U.S. Pat. No. 7,381,209; U.S. Pub. No. 2011/0087218; and/or U.S. Pat. App. No. 13/151,181. As described therein and as will be described in greater detail below, electrosurgical instrument (10) is operable to cut tissue and seal or weld tissue (e.g., a blood vessel, etc.) substantially simultaneously. In other words, electrosurgical instrument (10) operates similar to an endocutter type of stapler, except that electrosurgical instrument (10) provides tissue welding through application of bipolar RF energy instead of providing lines of staples to join tissue. It should also be understood that electrosurgical instrument (10) may have various structural and functional similarities with the ENSEAL® Tissue Sealing Device by Ethicon Endo-Surgery, Inc., of Cincinnati, Ohio. Furthermore, electrosurgical instrument (10) may have various structural and functional similarities with the devices taught in any of the other references that are cited and incorporated by reference herein. To the extent that there is some degree of overlap between the teachings of the references cited herein, the ENSEAL® Tissue Sealing Device by Ethicon Endo-Surgery, Inc., of Cincinnati, Ohio, and the following teachings relating to electrosurgical instrument (10), there is no intent for any of the description herein to be presumed as admitted prior art. Several teachings below will in fact go beyond the scope of the teachings of the references cited herein and the ENSEAL® Tissue Sealing Device by Ethicon Endo-Surgery, Inc., of Cincinnati, Ohio.

**[00031]** A. Exemplary Handpiece and Shaft

**[00032]** Electrosurgical instrument (10) of the present example includes a handpiece (20), a shaft (30) extending distally from handpiece (20), and an end effector (40) disposed at a



distal end of shaft (30). Handpiece (20) of the present example includes a pistol grip (22), a pivoting trigger (24), an activation button (26), and an articulation control (28). Trigger (24) is pivotable toward and away from pistol grip (22) to selectively actuate end effector (40) as will be described in greater detail below. Activation button (26) is operable to selectively activate RF circuitry that is in communication with end effector (40), as will also be described in greater detail below. In some versions, activation button (26) also serves as a mechanical lockout against trigger (24), such that trigger (24) cannot be fully actuated unless button (26) is being pressed simultaneously. Examples of how such a lockout may be provided are disclosed in one or more of the references cited herein. It should be understood that pistol grip (22), trigger (24), and button (26) may be modified, substituted, supplemented, etc. in any suitable way, and that the descriptions of such components herein are merely illustrative. Articulation control (28) of the present example is operable to selectively control articulation section (36) of shaft (30), which will be described in greater detail below. Various examples of forms that articulation control (28) may take will also be described in greater detail below, while further examples will be apparent to those of ordinary skill in the art in view of the teachings herein.

**[00033]** Shaft (30) of the present example includes an outer sheath (32) and an articulation section (36). Articulation section (36) is operable to selectively position end effector (40) at various angles relative to the longitudinal axis defined by sheath (32). Various examples of forms that articulation section (36) and other components of shaft (30) may take will be described in greater detail below, while further examples will be apparent to those of ordinary skill in the art in view of the teachings herein. For instance, it should be understood that various components that are operable to actuate articulation section (36) may extend through the interior of sheath (32). In some versions, shaft (30) is also rotatable about the longitudinal axis defined by sheath (32), relative to handpiece (20), via a knob (34). Such rotation may provide rotation of end effector (40) and shaft (30) unitarily. In some other versions, knob (34) is operable to rotate end effector (40) without rotating any portion of shaft (30) that is proximal of articulation section (36). As another merely illustrative example, electrosurgical instrument (10) may include one rotation control that provides rotatability of shaft (30) and end effector (40) as a single

unit; and another rotation control that provides rotatability of end effector (40) without rotating any portion of shaft (30) that is proximal of articulation section (36). Other suitable rotation schemes will be apparent to those of ordinary skill in the art in view of the teachings herein. Of course, rotatable features may simply be omitted if desired.

**[00034]**                    B.        Exemplary End Effector

**[00035]**            End effector (40) of the present example comprises a first jaw (42) and a second jaw (44). In the present example, second jaw (44) is substantially fixed relative to shaft (30); while first jaw (42) pivots relative to shaft (30), toward and away from second jaw (44). In some versions, actuators such as rods or cables, etc., may extend through sheath (32) and be joined with first jaw (42) at a pivotal coupling (43), such that longitudinal movement of the actuator rods/cables/etc. through shaft (30) provides pivoting of first jaw (42) relative to shaft (30) and relative to second jaw (44). Of course, jaws (42, 44) may instead have any other suitable kind of movement and may be actuated in any other suitable fashion. By way of example only, and as will be described in greater detail below, jaws (42, 44) may be actuated and thus closed by longitudinal translation of a firing beam (60), such that actuator rods/cables/etc. may simply be eliminated in some versions.

**[00036]**            As best seen in FIGS. 2-4, first jaw (42) defines a longitudinally extending elongate slot (46); while second jaw (44) also defines a longitudinally extending elongate slot (48). In addition, the top side of first jaw (42) presents a first electrode surface (50); while the underside of second jaw (44) presents a second electrode surface (52). Electrode surfaces (50, 52) are in communication with an electrical source (80) via one or more conductors (not shown) that extend along the length of shaft (30). Electrical source (80) is operable to deliver RF energy to first electrode surface (50) at a first polarity and to second electrode surface (52) at a second (opposite) polarity, such that RF current flows between electrode surfaces (50, 52) and thereby through tissue captured between jaws (42, 44). In some versions, firing beam (60) serves as an electrical conductor that cooperates with electrode surfaces (50, 52) (e.g., as a ground return) for delivery of bipolar RF energy captured between jaws (42, 44). Electrical source (80) may be external to electrosurgical instrument (10) or may be integral with electrosurgical

instrument (10) (e.g., in handpiece (20), etc.), as described in one or more references cited herein or otherwise. A controller (82) regulates delivery of power from electrical source (80) to electrode surfaces (50, 52). Controller (82) may also be external to electrosurgical instrument (10) or may be integral with electrosurgical instrument (10) (e.g., in handpiece (20), etc.), as described in one or more references cited herein or otherwise. It should also be understood that electrode surfaces (50, 52) may be provided in a variety of alternative locations, configurations, and relationships.

**[00037]** As best seen in FIG. 4, the lower side of first jaw (42) includes a longitudinally extending recess (58) adjacent to slot (46); while the upper side of second jaw (44) includes a longitudinally extending recess (58) adjacent to slot (48). FIG. 2 shows the upper side of first jaw (42) including a plurality of teeth serrations (46). It should be understood that the lower side of second jaw (44) may include complementary serrations that nest with serrations (46), to enhance gripping of tissue captured between jaws (42, 44) without necessarily tearing the tissue. FIG. 3 shows an example of serrations (46) in first jaw (42) as mainly recesses; with serrations (48) in second jaw (44) as mainly protrusions. Of course, serrations (46, 48) may take any other suitable form or may be simply omitted altogether. It should also be understood that serrations (46, 48) may be formed of an electrically non-conductive, or insulative, material, such as plastic, glass, and/or ceramic, for example, and may include a treatment such as polytetrafluoroethylene, a lubricant, or some other treatment to substantially prevent tissue from getting stuck to jaws (42, 44).

**[00038]** With jaws (42, 44) in a closed position, shaft (30) and end effector (40) are sized and configured to fit through trocars having various inner diameters, such that electrosurgical instrument (10) is usable in minimally invasive surgery, though of course electrosurgical instrument (10) could also be used in open procedures if desired. By way of example only, with jaws (42, 44) in a closed position, shaft (30) and end effector (40) may present an outer diameter of approximately 5 mm. Alternatively, shaft (30) and end effector (40) may present any other suitable outer diameter (e.g., between approximately 2 mm and approximately 20 mm, etc.).

**[00039]** As another merely illustrative variation, either jaw (42, 44) or both of jaws (42, 44) may include at least one port, passageway, conduit, and/or other feature that is operable to draw steam, smoke, and/or other gases/vapors/etc. from the surgical site. Such a feature may be in communication with a source of suction, such as an external source or a source within handpiece (20), etc. In addition, end effector (40) may include one or more tissue cooling features (not shown) that reduce the degree or extent of thermal spread caused by end effector (40) on adjacent tissue when electrode surfaces (50, 52) are activated. Various suitable forms that such cooling features may take will be apparent to those of ordinary skill in the art in view of the teachings herein.

**[00040]** In some versions, end effector (40) includes one or more sensors (not shown) that are configured to sense a variety of parameters at end effector (40), including but not limited to temperature of adjacent tissue, electrical resistance or impedance of adjacent tissue, voltage across adjacent tissue, forces exerted on jaws (42, 44) by adjacent tissue, etc. By way of example only, end effector (40) may include one or more positive temperature coefficient (PTC) thermistor bodies (54, 56) (e.g., PTC polymer, etc.), located adjacent to electrodes (50, 52) and/or elsewhere. Data from sensors may be communicated to controller (82). Controller (82) may process such data in a variety of ways. By way of example only, controller (82) may modulate or otherwise change the RF energy being delivered to electrode surfaces (50, 52), based at least in part on data acquired from one or more sensors at end effector (40). In addition or in the alternative, controller (82) may alert the user to one or more conditions via an audio and/or visual feedback device (e.g., speaker, lights, display screen, etc.), based at least in part on data acquired from one or more sensors at end effector (40). It should also be understood that some kinds of sensors need not necessarily be in communication with controller (82), and may simply provide a purely localized effect at end effector (40). For instance, a PTC thermistor bodies (54, 56) at end effector (40) may automatically reduce the energy delivery at electrode surfaces (50, 52) as the temperature of the tissue and/or end effector (40) increases, thereby reducing the likelihood of overheating. In some such versions, a PTC thermistor element is in series with power source (80) and electrode surface (50, 52); and the PTC thermistor provides an increased impedance (reducing flow of current) in response to temperatures exceeding a threshold. Furthermore, it should be understood

that electrode surfaces (50, 52) may be used as sensors (e.g., to sense tissue impedance, etc.). Various kinds of sensors that may be incorporated into electrosurgical instrument (10) will be apparent to those of ordinary skill in the art in view of the teachings herein. Similarly various things that can be done with data from sensors, by controller (82) or otherwise, will be apparent to those of ordinary skill in the art in view of the teachings herein. Other suitable variations for end effector (40) will also be apparent to those of ordinary skill in the art in view of the teachings herein.

**[00041]** C. Exemplary Firing Beam

**[00042]** As also seen in FIGS. 2-4, electrosurgical instrument (10) of the present example includes a firing beam (60) that is longitudinally movable along part of the length of end effector (40). Firing beam (60) is coaxially positioned within shaft (30), extends along the length of shaft (30), and translates longitudinally within shaft (30) (including articulation section (36) in the present example), though it should be understood that firing beam (60) and shaft (30) may have any other suitable relationship. Firing beam (60) includes a sharp distal blade (64), an upper flange (62), and a lower flange (66). As best seen in FIG. 4, distal blade (64) extends through slots (46, 48) of jaws (42, 44), with upper flange (62) being located above jaw (44) in recess (59) and lower flange (66) being located below jaw (42) in recess (58). The configuration of distal blade (64) and flanges (62, 66) provides an "I-beam" type of cross section at the distal end of firing beam (60). While flanges (62, 66) extend longitudinally only along a small portion of the length of firing beam (60) in the present example, it should be understood that flanges (62, 66) may extend longitudinally along any suitable length of firing beam (60). In addition, while flanges (62, 66) are positioned along the exterior of jaws (42, 44), flanges (62, 66) may alternatively be disposed in corresponding slots formed within jaws (42, 44). For instance, each jaw (42, 44) may define a "T"-shaped slot, with parts of distal blade (64) being disposed in one vertical portion of each "T"-shaped slot and with flanges (62, 66) being disposed in the horizontal portions of the "T"-shaped slots. Various other suitable configurations and relationships will be apparent to those of ordinary skill in the art in view of the teachings herein.

[00043] Distal blade (64) is substantially sharp, such that distal blade will readily sever tissue that is captured between jaws (42, 44). Distal blade (64) is also electrically grounded in the present example, providing a return path for RF energy as described elsewhere herein. In some other versions, distal blade (64) serves as an active electrode. In addition or in the alternative, distal blade (64) may be selectively energized with ultrasonic energy (e.g., harmonic vibrations at approximately 55.5 kHz, etc.).

[00044] The “I-beam” type of configuration of firing beam (60) provides closure of jaws (42, 44) as firing beam (60) is advanced distally. In particular, flange (62) urges jaw (44) pivotally toward jaw (42) as firing beam (60) is advanced from a proximal position (FIGS. 1-3) to a distal position (FIG. 4), by bearing against recess (59) formed in jaw (44). This closing effect on jaws (42, 44) by firing beam (60) may occur before distal blade (64) reaches tissue captured between jaws (42, 44). Such staging of encounters by firing beam (60) may reduce the force required to squeeze grip (24) to actuate firing beam (60) through a full firing stroke. In other words, in some such versions, firing beam (60) may have already overcome an initial resistance required to substantially close jaws (42, 44) on tissue before encountering resistance from the tissue captured between jaws (42, 44). Of course, any other suitable staging may be provided.

[00045] In the present example, flange (62) is configured to cam against a ramp feature at the proximal end of jaw (44) to open jaw (42) when firing beam (60) is retracted to a proximal position and to hold jaw (42) open when firing beam (60) remains at the proximal position. This camming capability may facilitate use of end effector (40) to separate layers of tissue, to perform blunt dissections, etc., by forcing jaws (42, 44) apart from a closed position. In some other versions, jaws (42, 44) are resiliently biased to an open position by a spring or other type of resilient feature. While jaws (42, 44) close or open as firing beam (60) is translated in the present example, it should be understood that other versions may provide independent movement of jaws (42, 44) and firing beam (60). By way of example only, one or more cables, rods, beams, or other features may extend through shaft (30) to selectively actuate jaws (42, 44) independently of firing beam (60). Such jaw (42, 44) actuation features may be separately controlled by a dedicated feature of handpiece (20). Alternatively, such jaw actuation features may be controlled by

trigger (24) in addition to having trigger (24) control firing beam (60). It should also be understood that firing beam (60) may be resiliently biased to a proximal position, such that firing beam (60) retracts proximally when a user relaxes their grip on trigger (24).

**[00046]** D. Exemplary Operation

**[00047]** In an exemplary use, end effector (40) is inserted into a patient via a trocar. Articulation section (36) is substantially straight when end effector (40) and part of shaft (30) are inserted through the trocar. Articulation control (28) may then be manipulated to pivot or flex articulation section (36) of shaft (30) in order to position end effector (40) at a desired position and orientation relative to an anatomical structure within the patient. Two layers of tissue of the anatomical structure are then captured between jaws (42, 44) by squeezing trigger (24) toward pistol grip (22). Such layers of tissue may be part of the same natural lumen defining anatomical structure (e.g., blood vessel, portion of gastrointestinal tract, portion of reproductive system, etc.) in a patient. For instance, one tissue layer may comprise the top portion of a blood vessel while the other tissue layer may comprise the bottom portion of the blood vessel, along the same region of length of the blood vessel (e.g., such that the fluid path through the blood vessel before use of electrosurgical instrument (10) is perpendicular to the longitudinal axis defined by end effector (40), etc.). In other words, the lengths of jaws (42, 44) may be oriented perpendicular to (or at least generally transverse to) the length of the blood vessel. As noted above, flanges (62, 66) cammingly act to pivot jaw (42) toward jaw (44) when firing beam (60) is actuated distally by squeezing trigger (24) toward pistol grip (22).

**[00048]** With tissue layers captured between jaws (42, 44) firing beam (60) continues to advance distally by the user squeezing trigger (24) toward pistol grip (22). As firing beam (60) advances distally, distal blade (64) simultaneously severs the clamped tissue layers, resulting in separated upper layer portions being apposed with respective separated lower layer portions. In some versions, this results in a blood vessel being cut in a direction that is generally transverse to the length of the blood vessel. It should be understood that the presence of flanges (62, 66) immediately above and below jaws (42, 44), respectively, may help keep jaws (42, 44) in a closed and tightly clamping position. In particular, flanges (62, 66) may help maintain a significantly compressive force

between jaws (42, 44). With severed tissue layer portions being compressed between jaws (42, 44), electrode surfaces (50, 52) are activated with bipolar RF energy by the user depressing activation button (26). In some versions, electrodes (50, 52) are selectively coupled with power source (80) (e.g., by the user depressing button (26), etc.) such that electrode surfaces (50, 52) of jaws (42, 44) are activated with a common first polarity while firing beam (60) is activated at a second polarity that is opposite to the first polarity. Thus, a bipolar RF current flows between firing beam (60) and electrode surfaces (50, 52) of jaws (42, 44), through the compressed regions of severed tissue layer portions. In some other versions, electrode surface (50) has one polarity while electrode surface (52) and firing beam (60) both have the other polarity. In either version (among at least some others), bipolar RF energy delivered by power source (80) ultimately thermally welds the tissue layer portions on one side of firing beam (60) together and the tissue layer portions on the other side of firing beam (60) together.

**[00049]** In certain circumstances, the heat generated by activated electrode surfaces (50, 52) can denature the collagen within the tissue layer portions and, in cooperation with clamping pressure provided by jaws (42, 44), the denatured collagen can form a seal within the tissue layer portions. Thus, the severed ends of the natural lumen defining anatomical structure are hemostatically sealed shut, such that the severed ends will not leak bodily fluids. In some versions, electrode surfaces (50, 52) may be activated with bipolar RF energy before firing beam (60) even begins to translate distally and thus before the tissue is even severed. For instance, such timing may be provided in versions where button (26) serves as a mechanical lockout relative to trigger (24) in addition to serving as a switch between power source (80) and electrode surfaces (50, 52).

**[00050]** While several of the teachings below are described as variations to electrosurgical instrument (10), it should be understood that various teachings below may also be incorporated into various other types of devices. By way of example only, in addition to being readily incorporated into electrosurgical instrument (10), various teachings below may be readily incorporated into the devices taught in any of the references cited herein, other types of electrosurgical devices, surgical staplers, surgical clip applicators, and tissue graspers, among various other devices. Other suitable devices into which the following



teachings may be incorporated will be apparent to those of ordinary skill in the art in view of the teachings herein.

**[00051]** II. Exemplary Articulation Joint Configurations

**[00052]** As noted above, some versions of shaft (30) include an articulation section (36), which is operable to selectively position end effector (40) at various angles relative to the longitudinal axis defined by sheath (32). Several examples of forms that articulation section (36) and other components of shaft (30) may take will be described in greater detail below, while further examples will be apparent to those of ordinary skill in the art in view of the teachings herein. By way of example only, some merely illustrative alternative examples of articulation section (36) are disclosed in U.S. Patent App. No. [ATTORNEY DOCKET NO. END6889USNP1], entitled "Articulation Joint Features for Articulating Surgical Device," filed on even date herewith, the disclosure of which is incorporated by reference herein

**[00053]** A. Exemplary Articulation Section with Parallel Support Rails

**[00054]** FIGS. 5-6 show an exemplary articulation section (100) disposed between a rigid shaft section (102) and an end effector (104). It should be understood that these features may be readily incorporated into electrosurgical instrument (10) described above, with shaft section (102) corresponding to shaft (30) and end effector (104) corresponding to end effector (40). Articulation section (100) of this example comprises a molded member (110) that defines a plurality of slots (112, 114, 116) and a pair of recesses (118). Molded member (110) may comprise a variety of materials, including but not limited to Vectra, Isoplast, a high density polyethylene, and/or various other materials. In some instances, the material forming molded member (110) provides a resilient bias to molded member (110) to assume a substantially straight orientation. Other suitable selections and properties for molded member (110) will be apparent to those of ordinary skill in the art in view of the teachings herein. Similarly, while molded member (110) is formed through a molding process in the present example, it should be understood that a variety of other processes may be used, including but not limited to extrusion, etc.

**[00055]** Slots (112, 114) extend longitudinally along the length of molded member (110), opening at a top portion of molded member (110) but terminating within the bottom portion of molded member (110). Slot (112) extends along the axis of molded member (110) while slots (114) are laterally offset from the axis. Slots (116) are oriented transversely relative to the axis of molded member (110). Like slots (112, 114), slots (116) also open at a top portion of molded member (110) while terminating within the bottom portion of molded member (110). Slots (116) are configured to facilitate flexing of molded member (110). Slot (112) is configured to slidably receive firing beam (160). Firing beam (160) is equivalent to firing beam (60) discussed above. It should therefore be understood that firing beam (160) is operable to translate longitudinally within slot (112). It should also be understood that firing beam (160) has sufficient flexibility to enable firing beam to translate along a curved path when articulation section is in a bent, articulated configuration. The material forming molded member (110) and/or coatings on molded member (110) may be selected to minimize friction between firing beam (160) and molded member (110). By way of example only, molded member (110) may include baked on silicone and/or sodium stearate and/or various other materials.

**[00056]** Recesses (118) are configured to receive articulation bands (140, 142). The distal ends of articulation bands (140, 142) are secured to the distal end of articulation section (100). The proximal ends of articulation bands (140, 142) are in communication with a control such as articulation control (28). In some versions, articulation control (28) is operable to selectively advance or retract one band (140, 142) while keeping the position of the other band (140, 142) substantially constant, thereby causing articulation section (100) to bend. In some other versions, articulation control (28) is operable to selectively advance band (140) while simultaneously retracting band (142); and/or to selectively retract band (140) while simultaneously advancing band (142). Of course, bands (140, 142) may be substituted with cables and/or various other types of components. A flexible sheath or wrap may be positioned about articulation section (100), to assist in holding bands (140, 142) against molded member (110). In addition or in the alternative, molded member (110) may include vertically extending slots and/or other types of features that hold bands (140, 142) against molded member (110), including when articulation section (100) is in a bent configuration.

**[00057]** Slots (114) are configured to receive spring beams (150). In some versions, spring beams (150) are resiliently biased to orient molded member (110) in a substantially straight configuration. This resilient bias may also reduce binding loads on firing beam (160) when firing beam (160) translates through articulation section (100) in a bent configuration. Spring beams (150) are also configured to enhance the structural integrity of articulation section (100), such as by providing resistance to lateral buckling or blowout of firing beam (160) when firing beam (160) translates through articulation section (100) in a bent configuration. Since spring beams (150) are located in slots (114) that are separate from the slot (112) for firing beam (160), spring beams (150) do not come into contact with firing beam (160) during operation of articulation section (100) and/or during operation of firing beam (160). This spacing may also reduce pinch loads of spring beams (150) on firing beam (160).

**[00058]** In some versions, both ends of each spring beam (150) are unsecured to anything, such that spring beams (150) float freely within articulation section (100). In some other versions, one end of each spring beam (150) is secured relative to articulation section (100) while the other end of each spring beam (150) floats freely. Other suitable components, configurations, arrangements, and relationships will be apparent to those of ordinary skill in the art in view of the teachings herein. It should also be understood that any of slots (112, 114, 116) and/or some other component of articulation section (110) may accommodate one or more wires that provide electrical communication between end effector (104) and a power source.

**[00059]** B. Exemplary Articulation Section Formed by Molded Joint

**[00060]** FIGS. 7-9 show another exemplary articulation section (200) disposed between a rigid shaft section (202) and an end effector (204). It should be understood that these features may be readily incorporated into electrosurgical instrument (10) described above, with shaft section (202) corresponding to shaft (30) and end effector (204) corresponding to end effector (40). Articulation section (200) of this example comprises a molded member (210) that defines a plurality of slots (212, 216), a lumen (214), and a pair of recesses (218). Molded member (210) may comprise a variety of materials, including but not limited to Vectra, Isoplast, a high density polyethylene, and/or various

other materials. In some instances, the material forming molded member (210) provides a resilient bias to molded member (210) to assume a substantially straight orientation. Other suitable selections and properties for molded member (210) will be apparent to those of ordinary skill in the art in view of the teachings herein. Similarly, while molded member (210) is formed through a molding process in the present example, it should be understood that a variety of other processes may be used.

**[00061]** As best seen in FIGS. 8-9, slot (212) and lumen (214) each extend longitudinally along the length of molded member (110). Slot (212) is configured to accommodate one or more wires that provide electrical communication between end effector (204) and a power source. Lumen (214) is configured to slidably receive a firing beam (not shown), much like slot (112) receiving firing beam (160) as described above. Thus, a firing beam may translate through molded member (210) regardless of whether articulation section (200) is in a substantially straight or bent configuration. Slots (216) are oriented transversely relative to the axis of molded member (210). Slots (216) are configured to facilitate flexing of molded member (210). In the present examples, as best seen in FIG. 9, slots (216) are alternately staggered in their relative spacing along the length of molded member (210). Such a configuration may facilitate bending of molded member (210). In some other versions, slots (216) are oppositely positioned instead of being staggered.

**[00062]** Recesses (218) are configured to receive articulation bands (240, 242). The distal ends of articulation bands (240, 242) are secured to the distal end of articulation section (200). The proximal ends of articulation bands (240, 242) are in communication with a control such as articulation control (28). In some versions, articulation control (28) is operable to selectively advance or retract one band (240, 242) while keeping the position of the other band (240, 242) substantially constant, thereby causing articulation section (200) to bend. In some other versions, articulation control (28) is operable to selectively advance band (240) while simultaneously retracting band (242); and/or to selectively retract band (240) while simultaneously advancing band (242). As yet another merely illustrative example, articulation control (28) may be operable to selectively advance band (240) while letting band (242) remain slack/free; and/or to selectively retract band

(240) while letting band (242) remain slack/free. Of course, bands (240, 242) may be substituted with cables and/or various other types of components; and may be operable in various other ways.

**[00063]** A flexible sheath or wrap may be positioned about articulation section (200), to assist in holding bands (240, 242) against molded member (210). In addition or in the alternative, molded member (210) may include vertically extending slots and/or other types of features that hold bands (240, 242) against molded member (210), including when articulation section (200) is in a bent configuration.

**[00064]** FIGS. 10-11 show another exemplary articulation section (300) disposed between a rigid shaft section (302) and an end effector (304). It should be understood that these features may be readily incorporated into electrosurgical instrument (10) described above, with shaft section (302) corresponding to shaft (30) and end effector (304) corresponding to end effector (40). Articulation section (300) of this example comprises a pair of molded members (310, 311). Each molded member (310, 311) may comprise a variety of materials, including but not limited to Vectra, Isoplast, a high density polyethylene, and/or various other materials. In some instances, the material forming molded members (310, 311) provides a resilient bias to molded members (310, 311) to assume a substantially straight orientation. Other suitable selections and properties for molded members (310, 311) will be apparent to those of ordinary skill in the art in view of the teachings herein. Similarly, while molded members (310, 311) are formed through a molding process in the present example, it should be understood that a variety of other processes may be used. Molded members (310, 311) are configured to apposingly join together to form articulation section (300), as shown in FIG. 10. Molded members (310, 311) may be secured together in numerous ways, including but not limited to adhesives, ultrasonic welding, snap-fittings, clamps, clips, an external sheath, etc.

**[00065]** As best seen in FIGS. 11, molded member (310) includes a plurality of recesses (312, 314, 316, 318) and a plurality of ribs (320). Recesses (312, 314, 316, 318) all extend longitudinally along the length of molded member (310). Recess (312) is positioned on an upper side of molded member (310) while recesses (314, 316, 318) are positioned on a lower side of molded member (310). Ribs (320) extend laterally from

molded member (310) and are spaced apart equidistantly along the length of molded member. Recess (312) is configured to accommodate one or more wires that provide electrical communication between end effector (304) and a power source.

**[00066]** Molded member (311) also includes a plurality of recesses (313, 315, 317, 319) and a plurality of ribs (321). Recesses (313, 315, 317, 319) all extend longitudinally along the length of molded member (311). Recess (313) is positioned on an upper side of molded member (311) while recesses (315, 317, 319) are positioned on a lower side of molded member (311). Ribs (321) extend laterally from molded member (310) and are spaced apart equidistantly along the length of molded member. Recess (313) is configured to accommodate one or more wires that provide electrical communication between end effector (304) and a power source. In some versions, either recess (312) or recess (313) receives such a wire while the other recess (312, 313) does not receive a wire. In some other versions, each recess (312, 313) receives at least one respective wire.

**[00067]** When molded members (310, 311) are joined together as shown in FIG. 10, recesses (314, 315) align and cooperate to form a channel through which a firing beam (not shown) may be slidably disposed. This channel is thus functionally similar to lumen (214) described above. In addition, recesses (316, 317) align and cooperate to form a channel to receive a first articulation cable (not shown) while recesses (318, 319) align and cooperate to form a channel to receive a second articulation cable (not shown) when molded members (310, 311) are joined together. Such articulation cables may be operable in a manner similar to that described above for articulation bands (140, 142). In some other versions, recesses (316, 317, 318, 319) are configured to form channels that receive bands instead of cables. Other suitable features that may be used to provide articulation of articulation section (300) will be apparent to those of ordinary skill in the art in view of the teachings herein. As best seen in FIG. 10, ribs (320, 321) are configured to interleave with each other when molded members (310, 311) are joined together. However, it should be understood that ribs (320, 321) may instead align with each other, if desired. It should also be understood that ribs (320, 321) permit articulation section (300) to bend relative to its longitudinal axis regardless of whether ribs (320, 321) are aligned or interleaved. In some versions, an outer wrap or shrink tubing is provided

about the exterior of molded members (310, 311), though this is merely optional. Such a wrap or tubing may assist in holding molded members (310, 311) together.

**[00068]** FIGS. 12-13 show yet another exemplary articulation section (400) that is essentially a variation of articulation section (300) described above. Articulation section (400) is formed by a pair of apposed molded members (410, 411). Each molded member (410, 411) may comprise a variety of materials, including but not limited to Vectra, Isoplast, a high density polyethylene, and/or various other materials. In some instances, the material forming molded members (410, 411) has resilient properties and thereby biases molded members (410, 411) to assume a substantially straight orientation. In other words, molded members (410, 411) may have shape memory providing a bias to a substantially straight configuration. Other suitable selections and properties for molded members (410, 411) will be apparent to those of ordinary skill in the art in view of the teachings herein. Similarly, while molded members (410, 411) are formed through a molding process in the present example, it should be understood that a variety of other processes may be used.

**[00069]** Molded member (410) includes a plurality of recesses (414, 416, 418) and a plurality of ribs (420). Recesses (414, 416, 418) are essentially equivalent to recesses (314, 316, 318) described above, such that they will not be described in greater detail here. It should also be understood that molded member (410) may include a recess that is analogous to recess (312) described above. Likewise, molded member (411) includes a plurality of recesses (415, 417, 419) and a plurality of ribs (421), with recesses (415, 417, 419) being essentially equivalent to recesses (315, 317, 319) described above. Molded member (411) may also include a recess that is analogous to recess (313) described above.

**[00070]** Unlike molded member (310), molded member (410) includes a plurality of posts (430) extending downwardly from the underside of molded member (410). Ribs (420) of molded member (410) also include a plurality of recesses (422). Unlike molded member (311), molded member (411) includes a plurality of openings (431) that are configured to receive posts (430) when molded members (410, 411) are joined together. Ribs (421) of molded member (411) include a plurality of protrusions (423), which are received in

recesses (422) of corresponding ribs (420) of molded member (410) when molded members (410, 411) are joined together. Thus, unlike ribs (320, 321) of molded members (310, 311), ribs (420, 421) align with each other when molded members (410, 411) are joined together.

**[00071]** FIG. 13 illustrates another difference between molded members (410, 411) and molded members (310, 311). In particular, FIG. 13 shows how the thickness of a spine section (440) of molded members (410, 411) decreases along the length of articulation section (400). It should be understood that the left-hand side of FIG. 13 corresponds with the distal end of articulation section (400) while the right-hand side of FIG. 13 corresponds with the proximal end of articulation section (400). As shown, a proximal region (442) of spine section (440) has a width “W1” that is greater than the width “W2” of a distal region (444) of spine section (440). Such a configuration may reduce the amount of force necessary to bend the distal end of articulation section (400) relative to the longitudinal axis defined by articulation section (400). In other words, gradually reducing the width of spine section (440) along length of articulation section (400) may facilitate articulation of articulation section (400). Of course, any other suitable features or configurations may be used. In some versions, an outer wrap or shrink tubing is provided about the exterior of molded members (410, 411), though this is merely optional. Such a wrap or tubing may assist in holding molded members (410, 411) together.

**[00072]** C. Exemplary Beaded Articulation Section

**[00073]** FIGS. 14-20 show yet another exemplary articulation section (500) that is disposed between a rigid shaft section (502) and an end effector (504). As will be described in greater detail below, end effector (504) is coupled with a rotation section (580), which is positioned distal to articulation section (500). It should be understood that these features may be readily incorporated into electrosurgical instrument (10) described above, with shaft section (502) corresponding to shaft (30) and end effector (504) corresponding to end effector (40). However, as will be described in greater detail below, in some versions end effector (504) is rotatable relative to shaft section (502) and relative to articulation section (500). Articulation section (500) of this example



comprises a plurality of coaxially aligned beads (510). As best seen in FIGS. 15-16, each bead (510) includes a first face (512) and a second face (514). Each face (512, 514) has a convex configuration. With beads (510) positioned adjacent to each other, the convex configuration of faces (512, 514) may facilitate articulation of articulation section (520). For instance, the face (512) of one bead (510) may simply roll against the face (514) of an adjacent bead (510) during articulation.

**[00074]** The outer perimeter of each bead (510) also includes recesses (520, 522, 524) extending from face (512) to face (514). Beads (510) are all configured similarly in this example, such that corresponding recesses (520, 522, 524) of adjacent beads (510) may be readily aligned with each other. As shown in FIGS. 14 and 18-20, recesses (520, 522) receive respective articulation cables (540, 542). Articulation cables (540, 542) are operable in a manner similar to that described above for articulation bands (140, 142). Of course, cables (540, 542) may be substituted with bands and/or various other kinds of structures. Recess (524) is configured to receive a wire (544), as shown in FIG. 20. As will be described in greater detail below, wire (544) is configured to provide electrical communication between end effector (504) and a power source. It should be understood that, as with other wires referred to herein, wire (544) may readily bend with articulation section (500) when articulation section (500) is articulated.

**[00075]** Each bead (510) further includes a central bore (530) extending from face (512) to face (514). Bores (530) of all beads (510) are all substantially coaxially aligned when articulation section (500) is in a substantially straight configuration. As best seen in FIG. 17, a firing drive cable (560) extends through bores (530). Drive cable (560) of the present example comprises a multi-strand construction with sufficient tensile strength to support distal and proximal driving forces through drive cable (560). The construction of drive cable (560) also permits drive cable (560) to be used to rotatably drive end effector (504) in either direction as will be described in greater detail below. As also best seen in FIG. 17, each bore (530) has a tapered configuration, which may facilitate flexing of drive cable (560) through articulation section (500) when articulation section (500) is in an articulated configuration. Bores (530) are also sized to permit rotation of drive cable (560) within beads (510), as will be described in greater detail below. In some versions,

an outer wrap or shrink tubing is provided about the exterior of beads (510), though this is merely optional. Such a wrap or tubing may assist in holding beads (510) together.

[00076] Drive cable (560) is secured to a firing bar (562) via an adapter (561) in a region distal to articulation section (500). Firing bar (562) is essentially equivalent to firing bar (60) described above. In particular, firing bar (562) includes a distal blade (564) and a pair of flanges (566) that are configured to close jaws (506, 508) when firing bar (562) is advanced distally; and to open jaws (506, 508) when firing bar (562) is retracted proximally. Drive cable (560) is operable to drive firing bar (562) distally and proximally by translating drive cable (560) distally or proximally. Drive cable (560) may be translated by actuation of trigger (24) and/or in any other suitable fashion.

[00077] Other suitable components, features, configurations, and operabilities for the above described articulation sections (100, 200, 300, 400, 500) will be apparent to those of ordinary skill in the art in view of the teachings herein.

[00078] III. Exemplary Articulation Control Configurations

[00079] Articulation control (28) may take a variety of forms. By way of example only, articulation control (28) may be configured in accordance with one or more teachings of U.S. Patent App. No. [ATTORNEY DOCKET NO. END6888USNP], entitled "Control Features for Articulating Surgical Device," filed on even date herewith, the disclosure of which is incorporated by reference herein. As another merely illustrative example, articulation control (28) may be configured in accordance with one or more teachings of U.S. Patent App. No. [ATTORNEY DOCKET NO. END6888USNP1], entitled "Control Features for Articulating Surgical Device," filed on even date herewith, the disclosure of which is incorporated by reference herein. Furthermore, articulation section may be configured in accordance with the teachings of at least one other of the references cited herein. Various other suitable forms that articulation control (28) may take will be apparent to those of ordinary skill in the art in view of the teachings herein.

[00080] IV. Other Exemplary Features

[00081] It should be understood that any of the versions of electrosurgical instrument (10) described herein may include various other features in addition to or in lieu of those

described above. By way of example only, FIGS. 14 and 17-20 show an example of a distal rotation section (580) that may be used to provide rotatability of end effector (504) in a region that is distal to articulation section (500). In other words, rotation section (580) and end effector (504) may be rotated together while articulation section (500) and shaft section (502) remain substantially stationary. It should be understood that rotation section (580) and end effector (504) may be rotated together regardless of whether articulation section (500) is in a substantially straight configuration or a bent/articulated configuration.

**[00082]** In the present example, rotation section (580) and end effector (504) are rotated by rotating drive cable (560). For instance, in some versions, handpiece (20) includes a knob or other feature that is operable to rotate drive cable (560). In some other versions, handpiece (20) is omitted, and rotation section (580) and end effector (504) are driven by motor, solenoid, and/or some other feature, as part of a robotic system. Other suitable components, configurations, and techniques for driving rotation system and end effector (504) will be apparent to those of ordinary skill in the art in view of the teachings herein. It should also be understood that an electrosurgical instrument (10) may provide both of two forms of rotation. For instance, one form of rotation may include simultaneous rotation of shaft section (502), articulation section (500), rotation section (580), and end effector (504) (regardless of whether articulation section (500) is in a straight or bent configuration); while another form of rotation may include rotation of only rotation section (580) and end effector (504), with shaft section (502) and articulation section (500) remaining rotationally stationary (again regardless of whether articulation section (500) is in a straight or bent configuration).

**[00083]** As noted above, wire (544) passes through articulation section (500) to provide electrical communication between end effector (504) and a power source that is proximal to shaft (502). In some the present example, rotation section (580) is configured to permit electrical power to be communicated from wire (544) to end effector (504) without wire (544) getting wrapped or twisted when end effector (504) is rotated relative to articulation section (500). In particular, and as best seen in FIGS. 19-20, wire (544) is secured to a prong (584) of a slip ring (586). Slip ring (586) is positioned and resiliently

biased to contact a cuff (590), which includes distally extending arms (594). Prong (584), slip ring (586), cuff (590), and extending arms (594) each comprise an electrically conductive material. These components are all contained within a sheath (582). Arms (594) are in electrical communication with one or both of jaws (506, 508), to provide bipolar RF energy through either or both jaws (506, 508) as described above and as described in various references that are cited herein.

**[00084]** Cuff (590) is secured to a body (592) within rotation section (580). Cuff (590) and body (592) rotate together with end effector (504). The relationship between slip ring (586) and cuff (590) provides electrical continuity between slip ring (586) and cuff (590) even as cuff (590) rotates with end effector (504) while slip ring (586) and articulation section (500) remain rotationally stationary. It should be understood that one or more bearing surfaces or features may also be provided between articulation section (500) and rotation section (580) to further facilitate rotation of rotation section (580) relative to articulation section (580).

**[00085]** While the example shown in FIGS. 14 and 17-20 is provided in the context of articulation section (500), it should be understood that rotation section (580) may also be readily incorporated into any of the other versions of articulation sections or electro-surgical instrument (10) described herein. It should also be understood that rotation section (580) may be readily incorporated into various other kinds of instruments as well, including but not limited to the various kinds of instruments that are described herein and/or that are described in the various references that are cited herein. Still other suitable instruments in which rotation section (580) may be incorporated will be apparent to those of ordinary skill in the art in view of the teachings herein.

**[00086]** It should be understood that any of the devices herein may also include one or more of the various features disclosed in U.S. Patent App. No. [ATTORNEY DOCKET NO. END6888USNP], entitled "Control Features for Articulating Surgical Device," filed on even date herewith, the disclosure of which is incorporated by reference herein; U.S. Patent App. No. [ATTORNEY DOCKET NO. END6888USNP1], entitled "Articulation Joint Features for Articulating Surgical Device," filed on even date herewith, the disclosure of which is incorporated by reference herein; and/or U.S. Patent App. No.

[ATTORNEY DOCKET NO. END6889USNP1], entitled "Control Features for Articulating Surgical Device," filed on even date herewith, the disclosure of which is incorporated by reference herein.

[00087] It should also be understood that any of the devices described herein may be modified to include a motor or other electrically powered device to drive an otherwise manually moved component. Various examples of such modifications are described in U.S. Patent App. No. 13/151,481, entitled "Motor Driven Electrosurgical Device with Mechanical and Electrical Feedback," filed June 2, 1011, the disclosure of which is incorporated by reference herein. Various other suitable ways in which a motor or other electrically powered device may be incorporated into any of the devices herein will be apparent to those of ordinary skill in the art in view of the teachings herein.

[00088] Furthermore, it should be understood that any of the devices described herein may be modified to contain most, if not all, of the required components within the medical device itself. More specifically, the devices described herein may be adapted to use an internal or attachable power source instead of requiring the device to be plugged into an external power source by a cable. Various examples of how medical devices may be adapted to include a portable power source are disclosed in U.S. Provisional Application Serial No. 61/410,603, filed November 5, 2010, entitled "Energy-Based Surgical Instruments," the disclosure of which is incorporated by reference herein. Various other suitable ways in which a power source may be incorporated into any of the devices herein will be apparent to those of ordinary skill in the art in view of the teachings herein.

[00089] VI. Miscellaneous

[00090] While the examples herein are described mainly in the context of electrosurgical instruments, it should be understood that the teachings herein may be readily applied to a variety of other types of medical instruments. By way of example only, the teachings herein may be readily applied to tissue graspers, tissue retrieval pouch deploying instruments, surgical staplers, ultrasonic surgical instruments, etc. It should also be understood that the teachings herein may be readily applied to any of the instruments described in any of the references cited herein, such that the teachings herein may be

readily combined with the teachings of any of the references cited herein in numerous ways. Other types of instruments into which the teachings herein may be incorporated will be apparent to those of ordinary skill in the art.

**[00091]** It should be appreciated that any patent, publication, or other disclosure material, in whole or in part, that is said to be incorporated by reference herein is incorporated herein only to the extent that the incorporated material does not conflict with existing definitions, statements, or other disclosure material set forth in this disclosure. As such, and to the extent necessary, the disclosure as explicitly set forth herein supersedes any conflicting material incorporated herein by reference. Any material, or portion thereof, that is said to be incorporated by reference herein, but which conflicts with existing definitions, statements, or other disclosure material set forth herein will only be incorporated to the extent that no conflict arises between that incorporated material and the existing disclosure material.

**[00092]** Embodiments of the present invention have application in conventional endoscopic and open surgical instrumentation as well as application in robotic-assisted surgery. For instance, those of ordinary skill in the art will recognize that various teaching herein may be readily combined with various teachings of U.S. Pat. No. 6,783,524, entitled "Robotic Surgical Tool with Ultrasound Cauterizing and Cutting Instrument," published August 31, 2004, the disclosure of which is incorporated by reference herein.

**[00093]** Embodiments of the devices disclosed herein can be designed to be disposed of after a single use, or they can be designed to be used multiple times. Embodiments may, in either or both cases, be reconditioned for reuse after at least one use. Reconditioning may include any combination of the steps of disassembly of the device, followed by cleaning or replacement of particular pieces, and subsequent reassembly. In particular, embodiments of the device may be disassembled, and any number of the particular pieces or parts of the device may be selectively replaced or removed in any combination. Upon cleaning and/or replacement of particular parts, embodiments of the device may be reassembled for subsequent use either at a reconditioning facility, or by a surgical team immediately prior to a surgical procedure. Those skilled in the art will appreciate that

reconditioning of a device may utilize a variety of techniques for disassembly, cleaning/replacement, and reassembly. Use of such techniques, and the resulting reconditioned device, are all within the scope of the present application.

**[00094]** By way of example only, embodiments described herein may be processed before surgery. First, a new or used instrument may be obtained and if necessary cleaned. The instrument may then be sterilized. In one sterilization technique, the instrument is placed in a closed and sealed container, such as a plastic or TYVEK bag. The container and instrument may then be placed in a field of radiation that can penetrate the container, such as gamma radiation, x-rays, or high-energy electrons. The radiation may kill bacteria on the instrument and in the container. The sterilized instrument may then be stored in the sterile container. The sealed container may keep the instrument sterile until it is opened in a medical facility. A device may also be sterilized using any other technique known in the art, including but not limited to beta or gamma radiation, ethylene oxide, or steam.

**[00095]** Having shown and described various embodiments of the present invention, further adaptations of the methods and systems described herein may be accomplished by appropriate modifications by one of ordinary skill in the art without departing from the scope of the present invention. Several of such potential modifications have been mentioned, and others will be apparent to those skilled in the art. For instance, the examples, embodiments, geometrics, materials, dimensions, ratios, steps, and the like discussed above are illustrative and are not required. Accordingly, the scope of the present invention should be considered in terms of the following claims and is understood not to be limited to the details of structure and operation shown and described in the specification and drawings.

I/We claim:

1. An electrosurgical device, comprising:
  - (a) a body;
  - (b) an end effector comprising:
    - (i) a first jaw, wherein the first jaw includes a first electrode, and
    - (ii) a second jaw, wherein the second jaw includes a second electrode, wherein the first jaw is movable toward the second jaw to clamp tissue between the first and second jaws, wherein the first and second electrodes are operable to deliver RF energy to tissue clamped between the first and second jaws;
  - (c) a cutting member operable to cut tissue clamped between the first jaw and the second jaw; and
  - (d) a shaft extending between the body and the end effector, wherein the shaft defines a longitudinal axis, wherein the shaft includes an articulation section, wherein the articulation section is operable to selectively position the end effector at non-parallel positions relative to the longitudinal axis of the shaft.
2. The electrosurgical device of claim 1, wherein the articulation section comprises a molded piece of plastic.
3. The electrosurgical device of claim 2, wherein the articulation section comprises a pair of complementary pieces of molded plastic apposed together.
4. The electrosurgical device of claim 1, wherein the articulation section comprises a plurality of recesses, wherein a portion of the cutting member is disposed in one of the recesses.
5. The electrosurgical device of claim 4, further comprising a resilient beam disposed in another recess of the plurality of recesses.



6. The electrosurgical device of claim 5, wherein the resilient beam is parallel to the portion of the cutting member disposed in one of the recesses.

7. The electrosurgical device of claim 1, wherein the articulation section comprises one or more articulation beams operable to selectively drive the end effector toward or away from the longitudinal axis of the shaft to thereby articulate the end effector.

8. The electrosurgical device of claim 1, wherein the articulation section presents a plurality of lateral recesses separating a plurality of laterally extending ribs positioned on two lateral sides of the articulation section, wherein the ribs positioned on a first lateral side of the articulation section are longitudinally offset relative to the ribs positioned on a second lateral side of the articulation section.

9. The electrosurgical device of claim 1, wherein the articulation section defines a recess configured to receive a wire to provide electrical power to the end effector.

10. The electrosurgical device of claim 1, wherein the articulation section presents a plurality of lateral recesses separating a plurality of laterally extending ribs positioned on two lateral sides of the articulation section, wherein a first set of the ribs are also positioned on a top half of the articulation section, wherein a second set of the ribs are positioned on a bottom half of the articulation section, wherein the first set of ribs are interleaved with the second set of ribs.

11. The electrosurgical device of claim 1, wherein the articulation section presents a plurality of lateral recesses separating a plurality of laterally extending ribs positioned on two lateral sides of the articulation section, wherein the articulation section further includes spine portions separating the two lateral sides of the articulation section, wherein a proximal spine portion has a first width at a proximal region of the articulation section, wherein a distal spine portion has a second width at a distal region of the articulation section.

12. The electrosurgical device of claim 11, wherein the second width is less than the first width.

13. The electrosurgical device of claim 12, wherein the width of the spine portions successively decreases past each pair of ribs from a proximal pair of ribs to a distal pair of ribs.

14. The electrosurgical device of claim 1, wherein the articulation section includes an outer shrink tubing.

15. The electrosurgical device of claim 1, wherein the articulation section comprises a plurality of beads.

16. The electrosurgical device of claim 15, wherein the beads each include a convex distal face and a convex proximal face.

17. The electrosurgical device of claim 1, wherein the shaft further comprises a rotation section, wherein the rotation section is distal to the articulation section, wherein the rotation section is operable to rotate the end effector relative to the articulation section.

18. The electrosurgical device of claim 1, wherein the body comprises a handpiece.

19. An electrosurgical device, comprising:

(a) a body;

(b) an end effector comprising:

(i) a first jaw, and

(ii) a second jaw,

wherein the first jaw is movable toward the second jaw to clamp tissue between the first and second jaw,

wherein at least one of the jaws comprises at least one electrode,

wherein the at least one electrode is operable to deliver RF energy to tissue clamped between the first and second jaw;

(c) a cutting member operable to cut tissue clamped between the first jaw and the second jaw; and

- (d) a shaft extending between the body and the end effector, wherein the shaft defines a longitudinal axis, wherein the shaft includes an articulation section, wherein the articulation section is operable to selectively position the end effector at non-parallel positions relative to the longitudinal axis of the shaft, wherein the articulation section comprises:
  - (i) a passageway, wherein a portion of the cutting member is slidably disposed in the passageway,
  - (ii) a first articulation member, and
  - (iii) a second articulation member,wherein the first articulation member and the second articulation member are operable to selectively deflect the end effector away from the longitudinal axis of the shaft.

20. An electrosurgical device, comprising:

- (a) a body;
- (b) an end effector comprising:
  - (i) a first jaw, and
  - (ii) a second jaw,wherein the first jaw is movable toward the second jaw to clamp tissue between the first and second jaw,  
wherein at least one of the jaws comprises at least one electrode,  
wherein the at least one electrode is operable to deliver RF energy to tissue clamped between the first and second jaw;
- (c) a cutting member operable to cut tissue clamped between the first jaw and the second jaw; and
- (d) a shaft extending between the body and the end effector, wherein the shaft defines a longitudinal axis, wherein the shaft includes:
  - (i) a proximal section,
  - (ii) an articulation section, wherein the articulation section is distal to the proximal section, wherein the articulation section is operable

- 34 -

to selectively position the end effector at non-parallel positions relative to the longitudinal axis of the shaft, and

- (iii) a rotation section, wherein the rotation section is distal to the articulation section, wherein the rotation section is operable to selectively rotate the end effector relative to the articulation section.

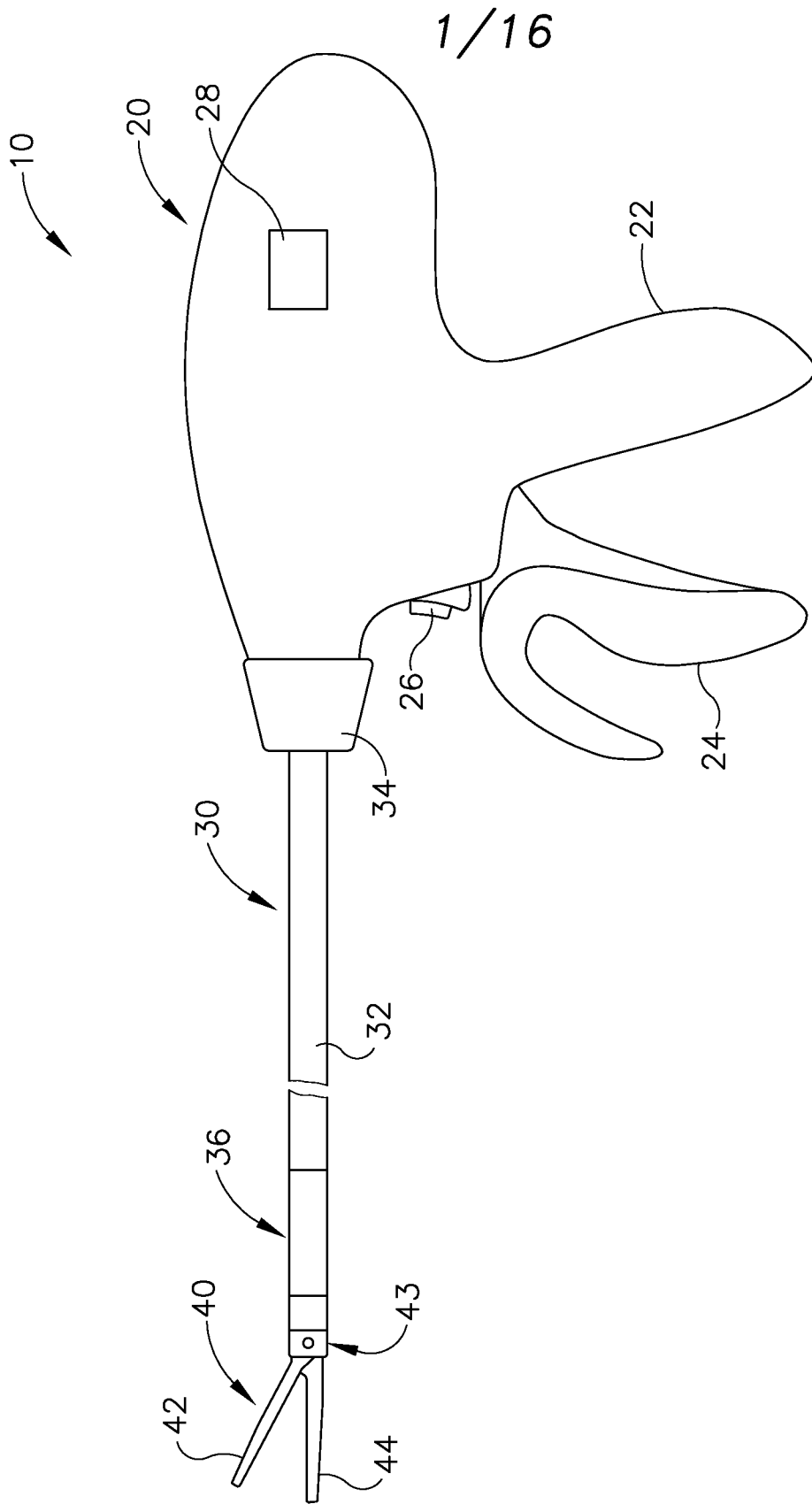

Fig. 1

2/16

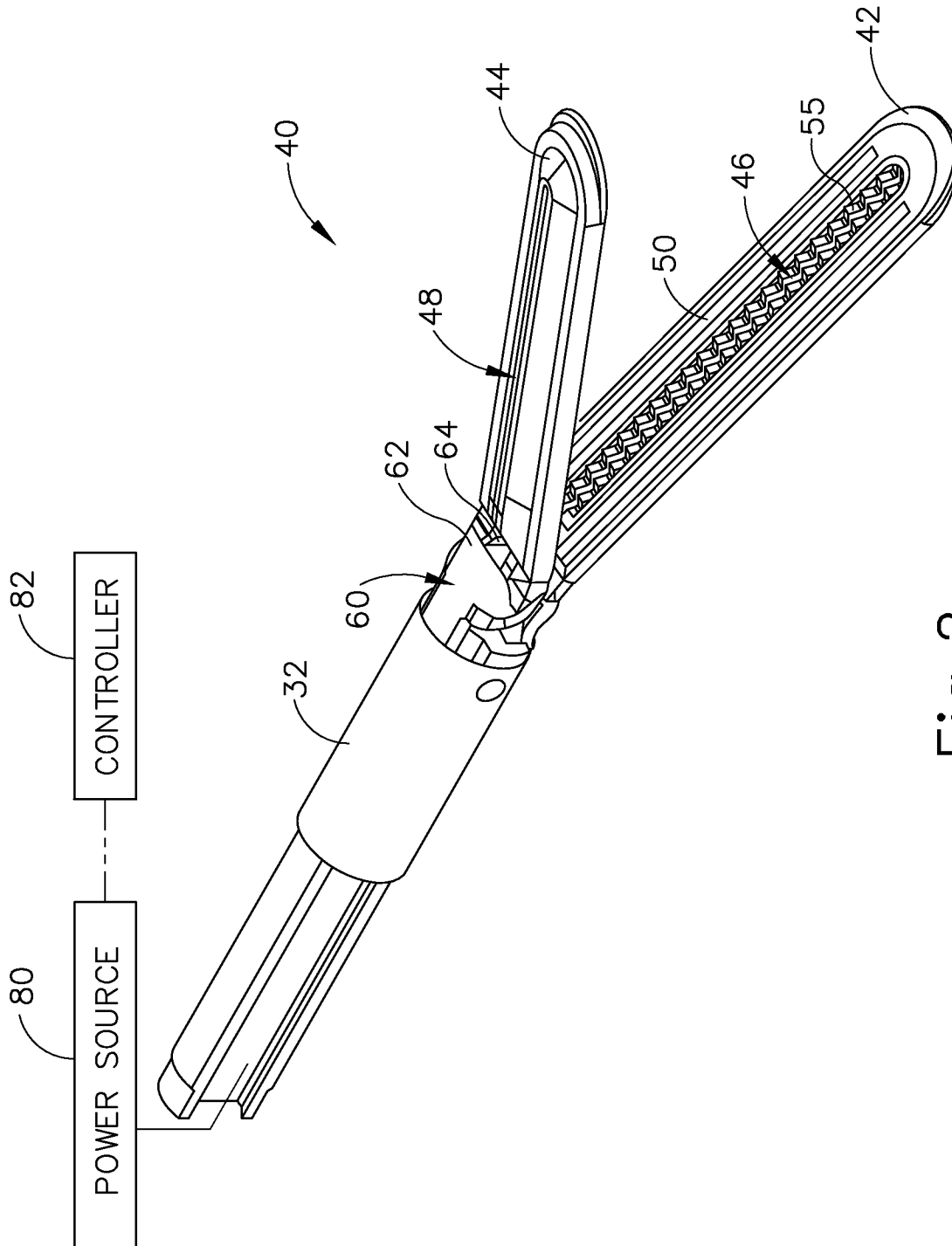

Fig. 2

3/16

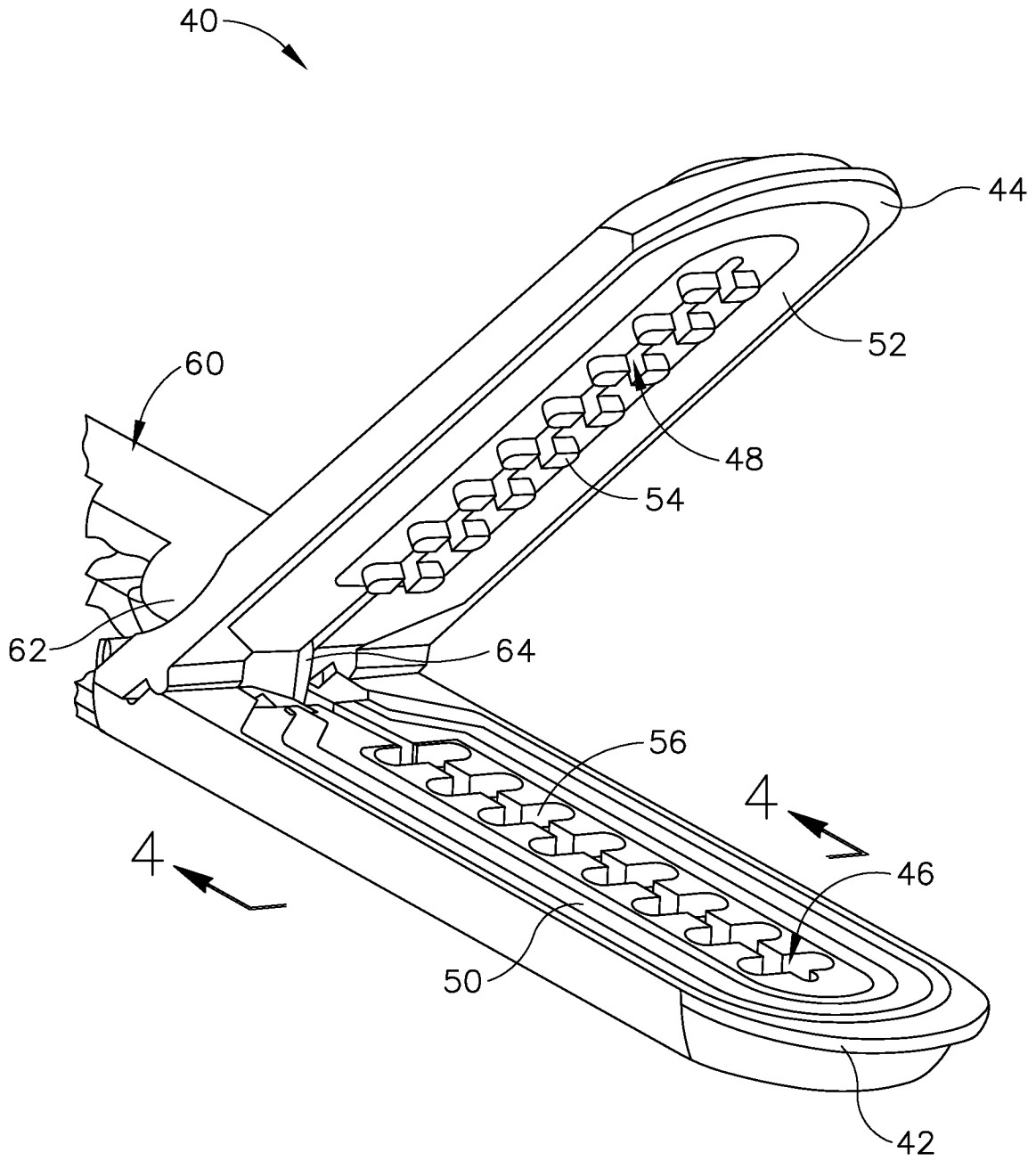

Fig.3

4/16

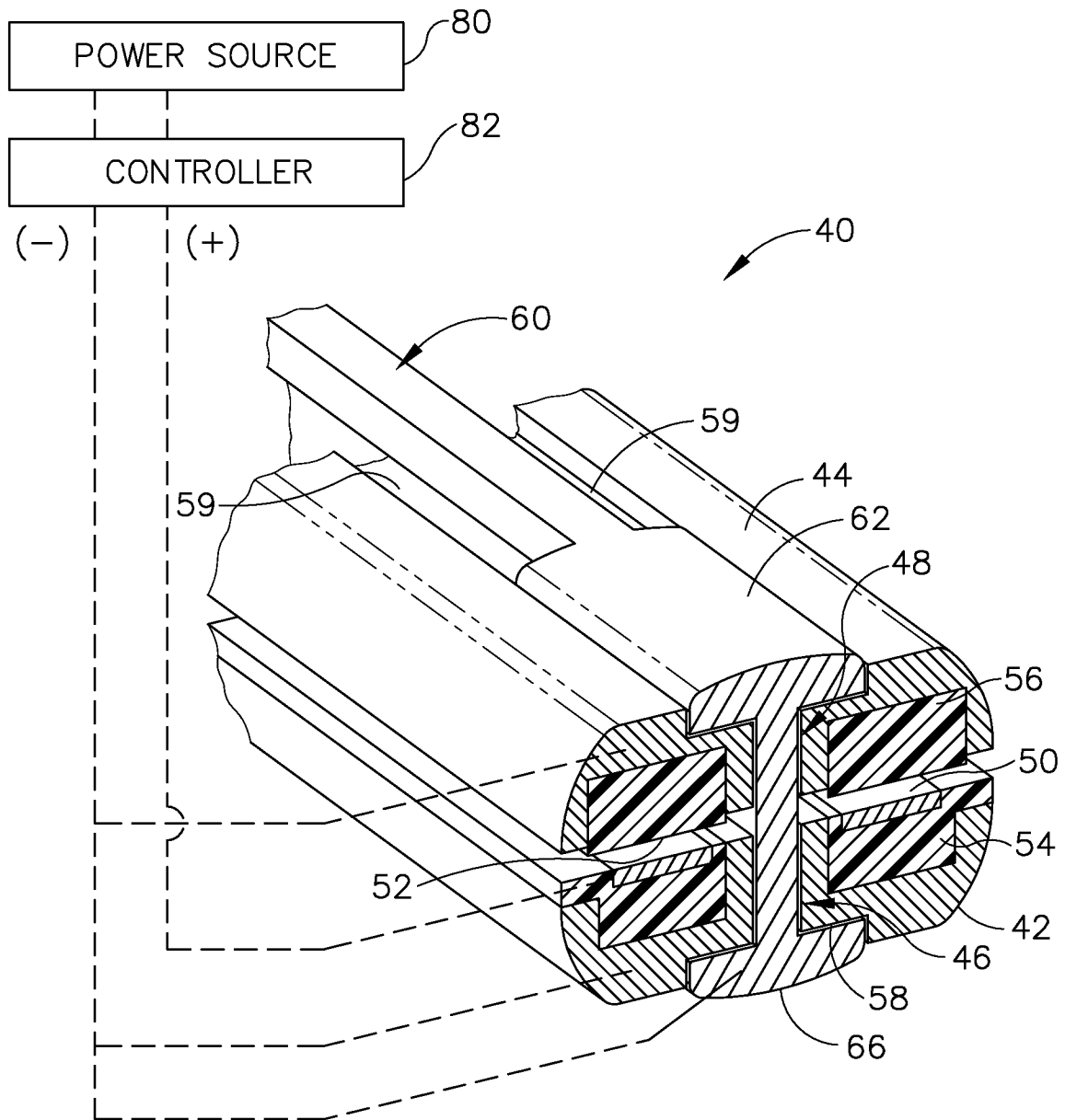

Fig.4



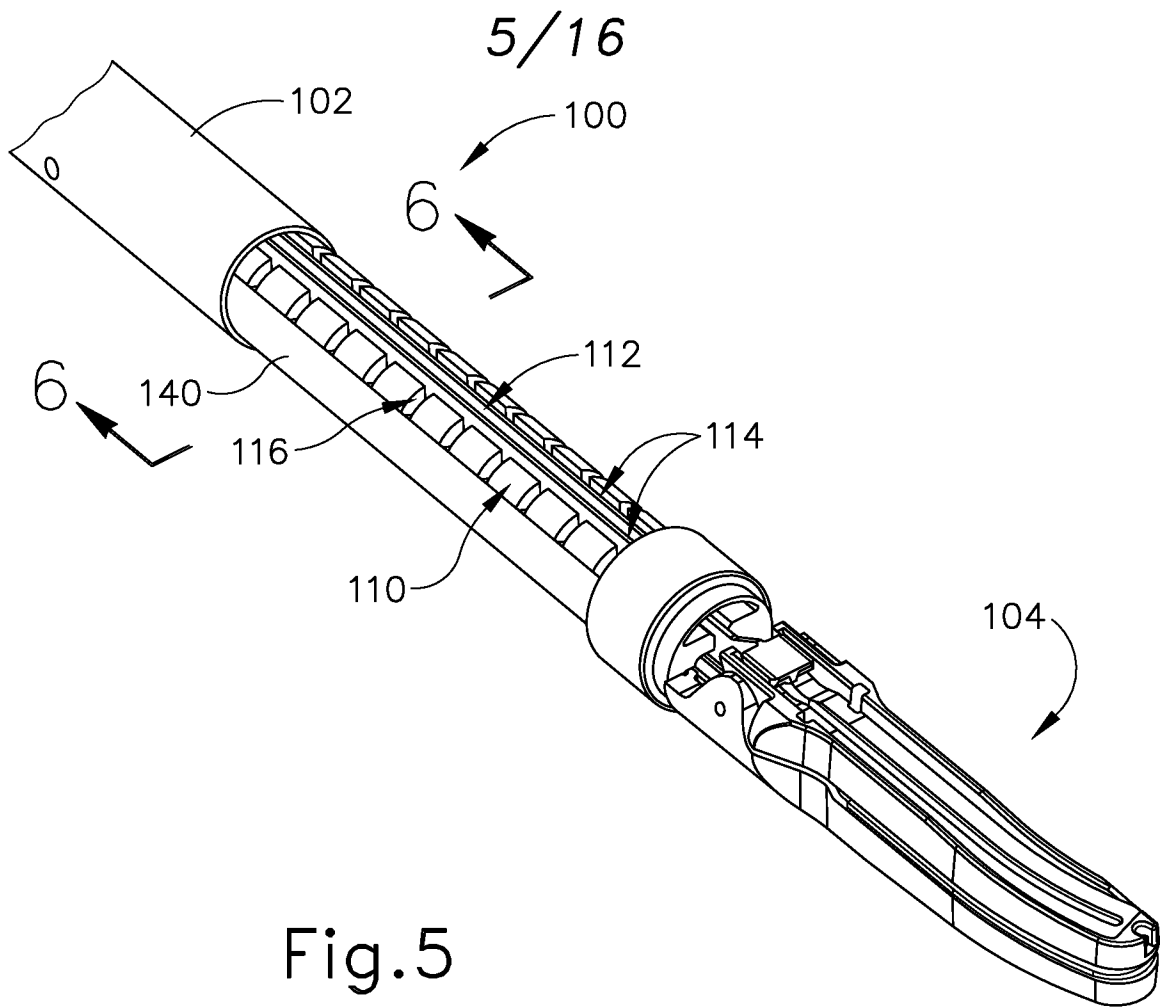

Fig.5

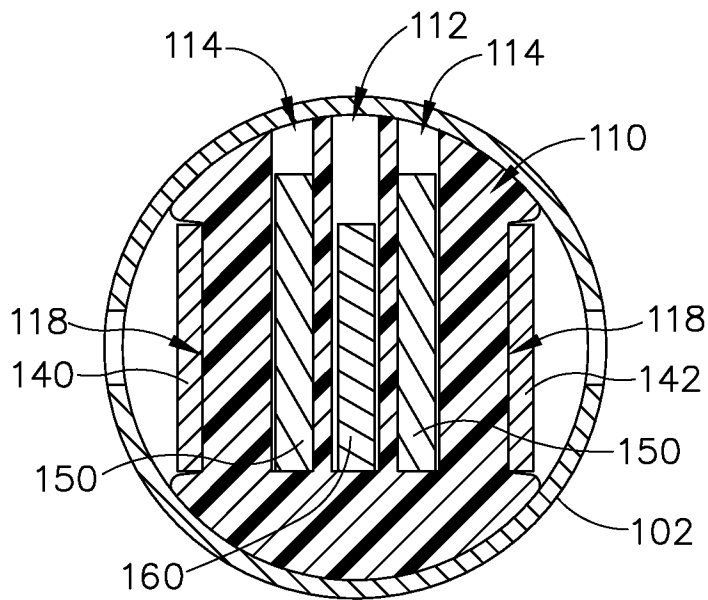

Fig.6

6/16

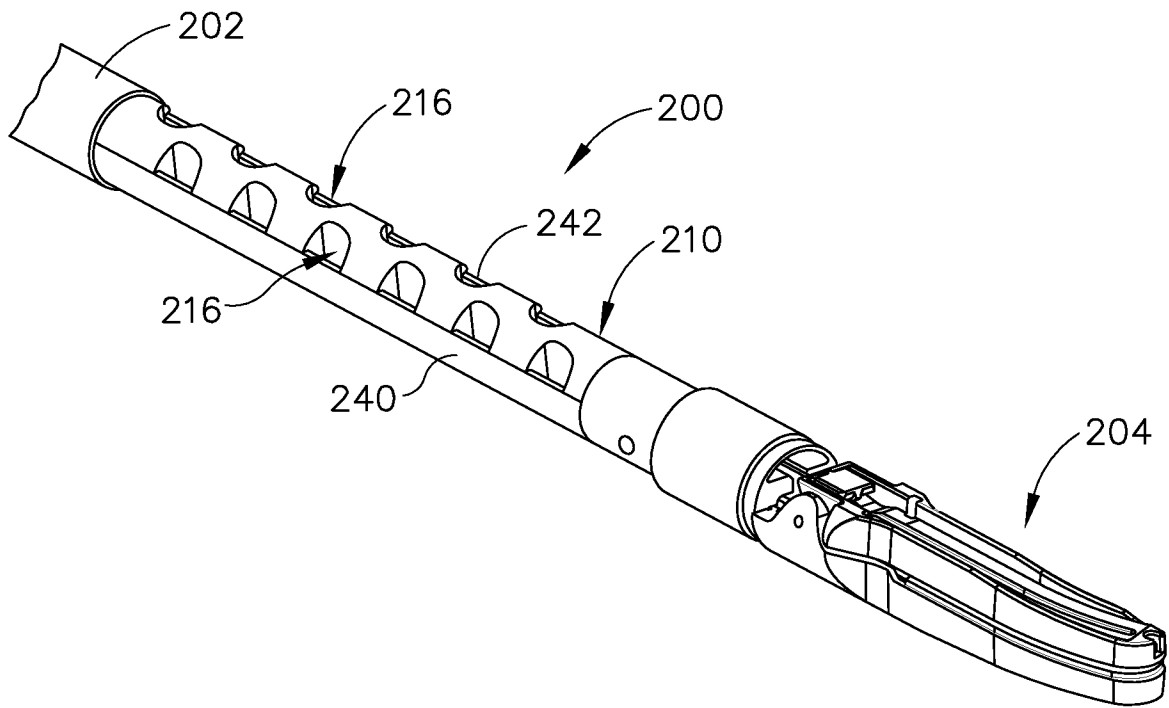

Fig. 7

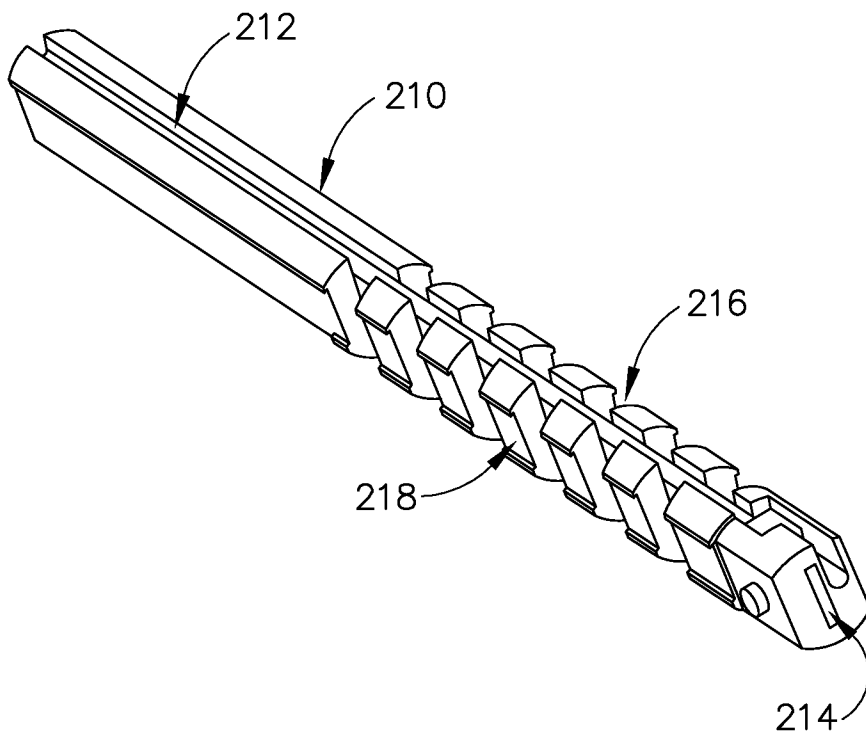

Fig. 8

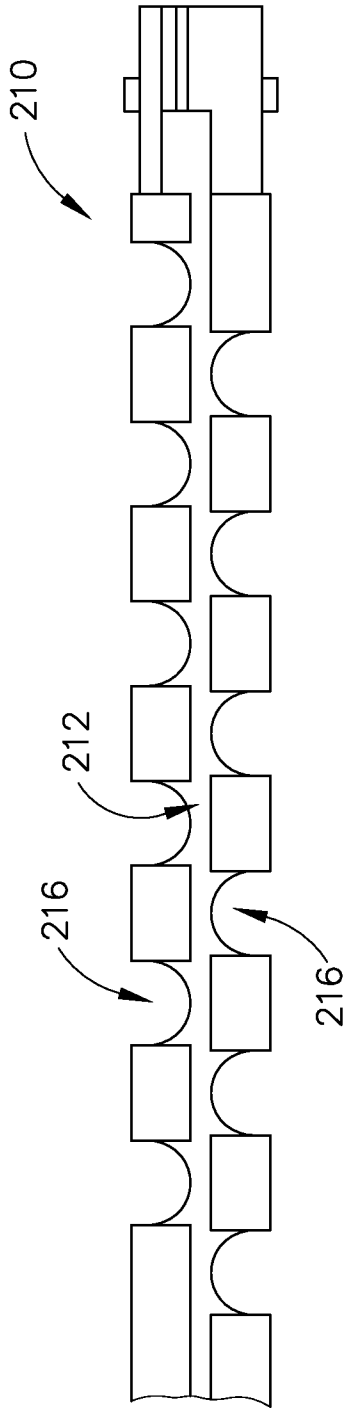

Fig. 9

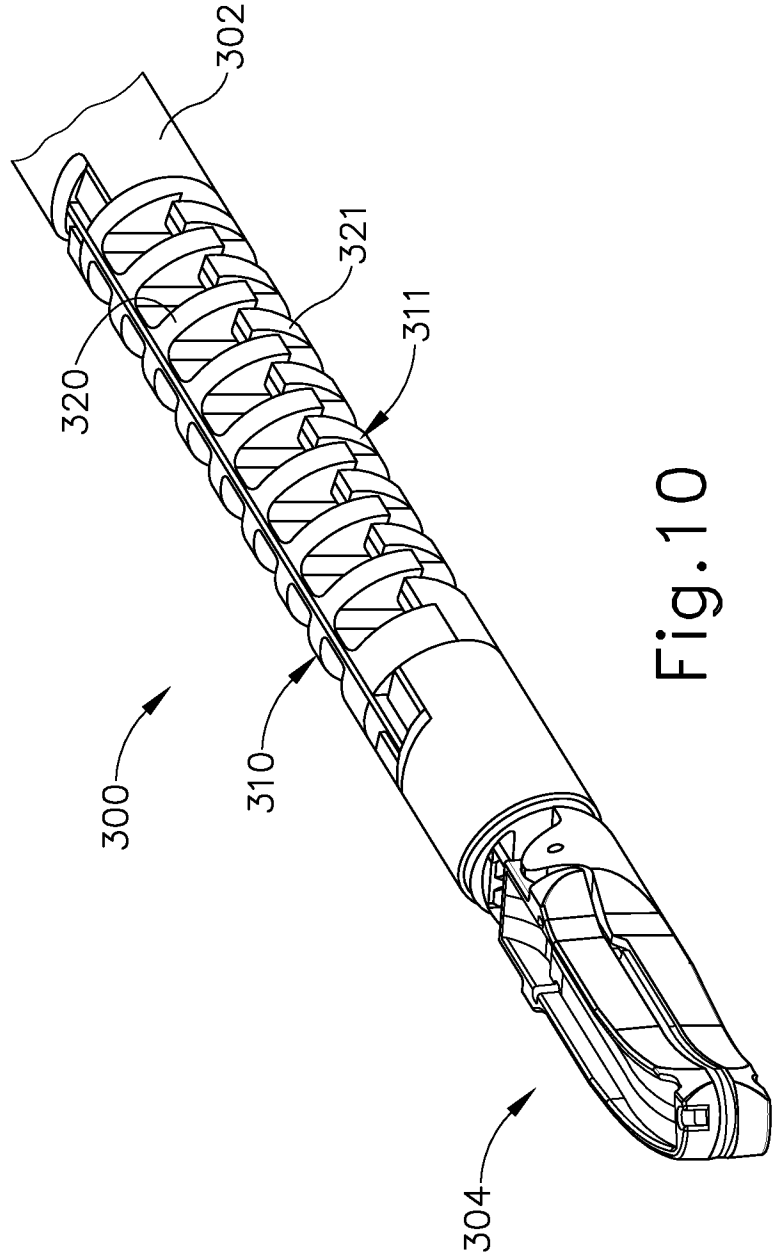

Fig. 10

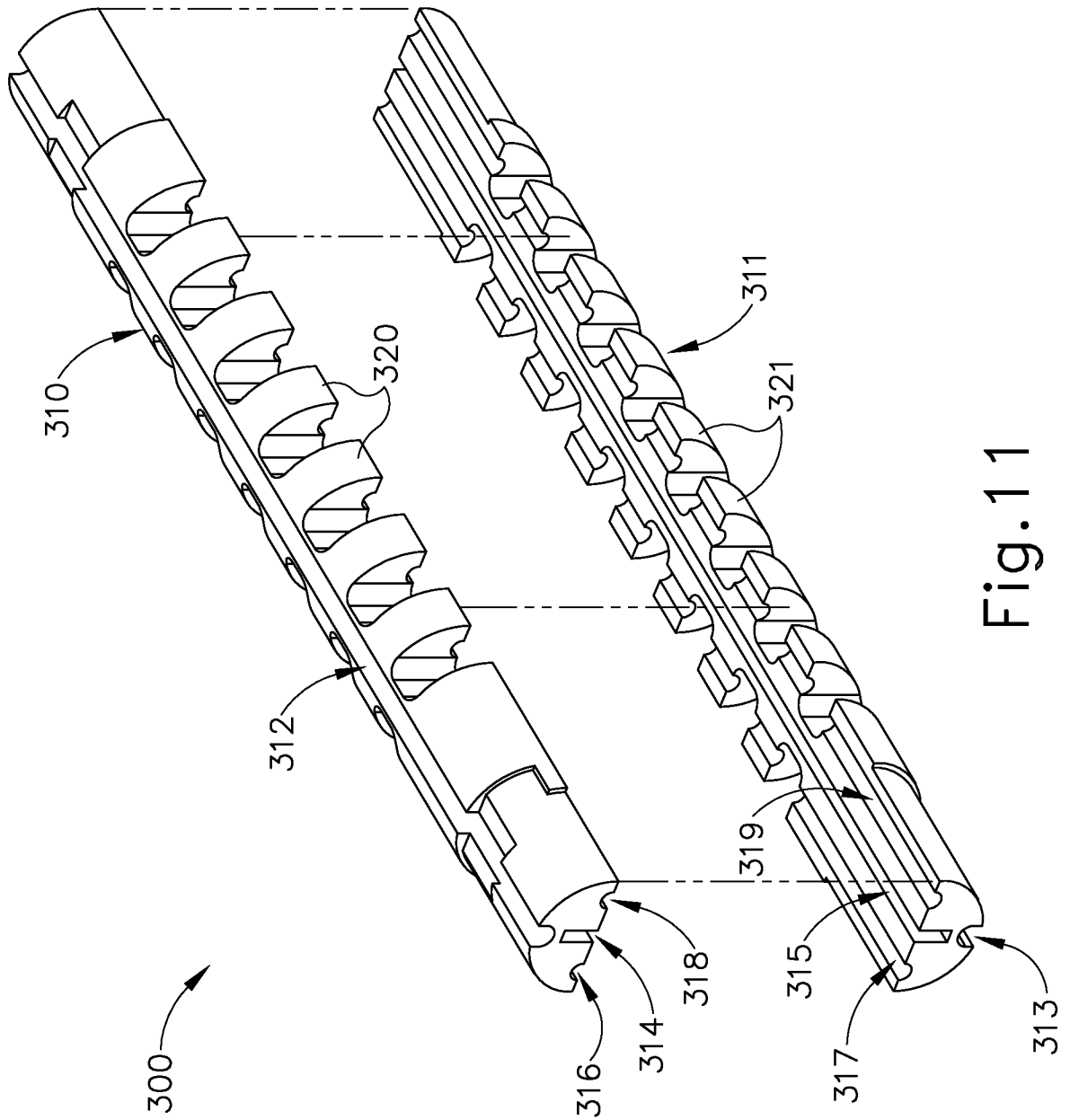

Fig. 11

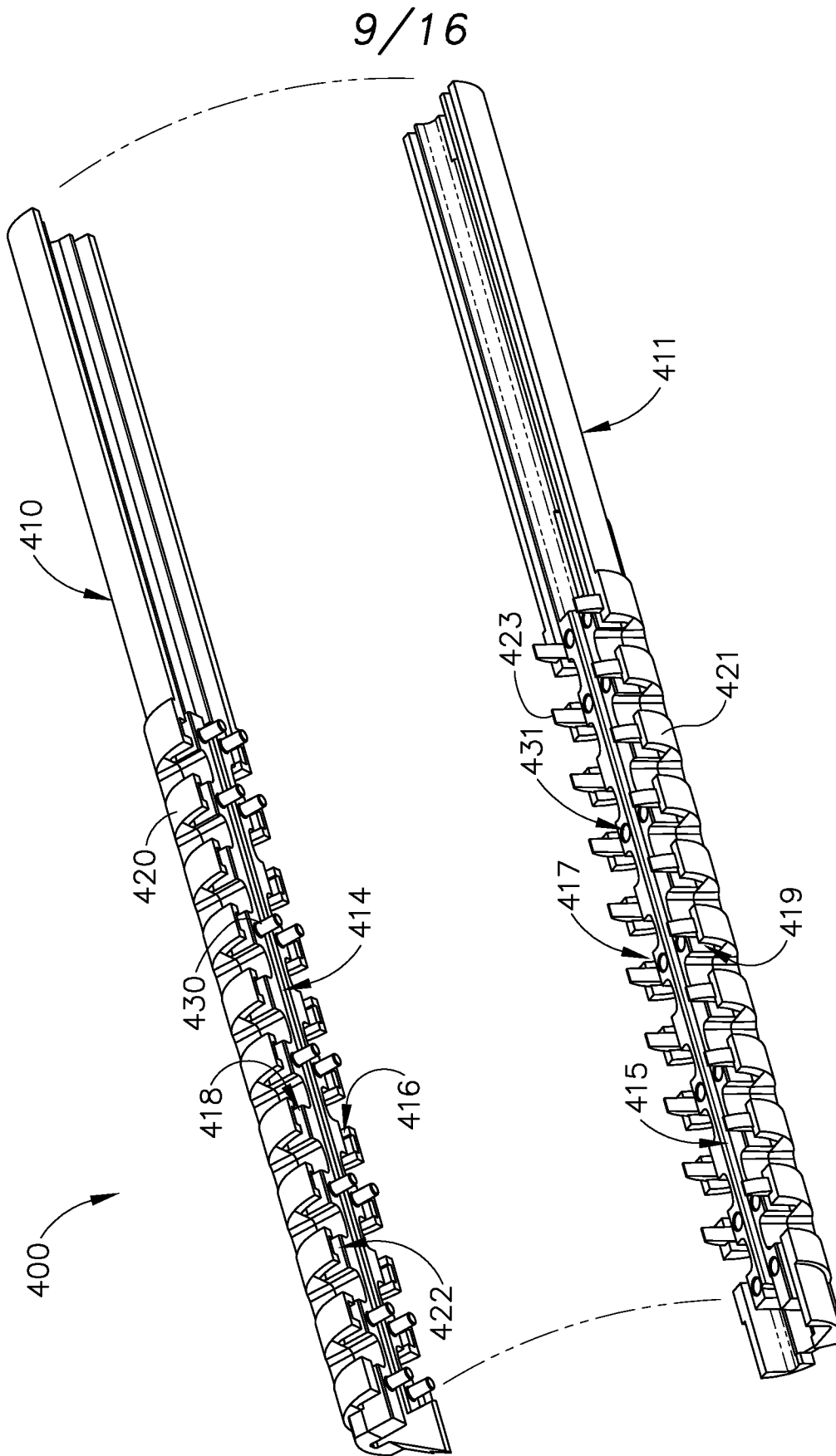

Fig.12

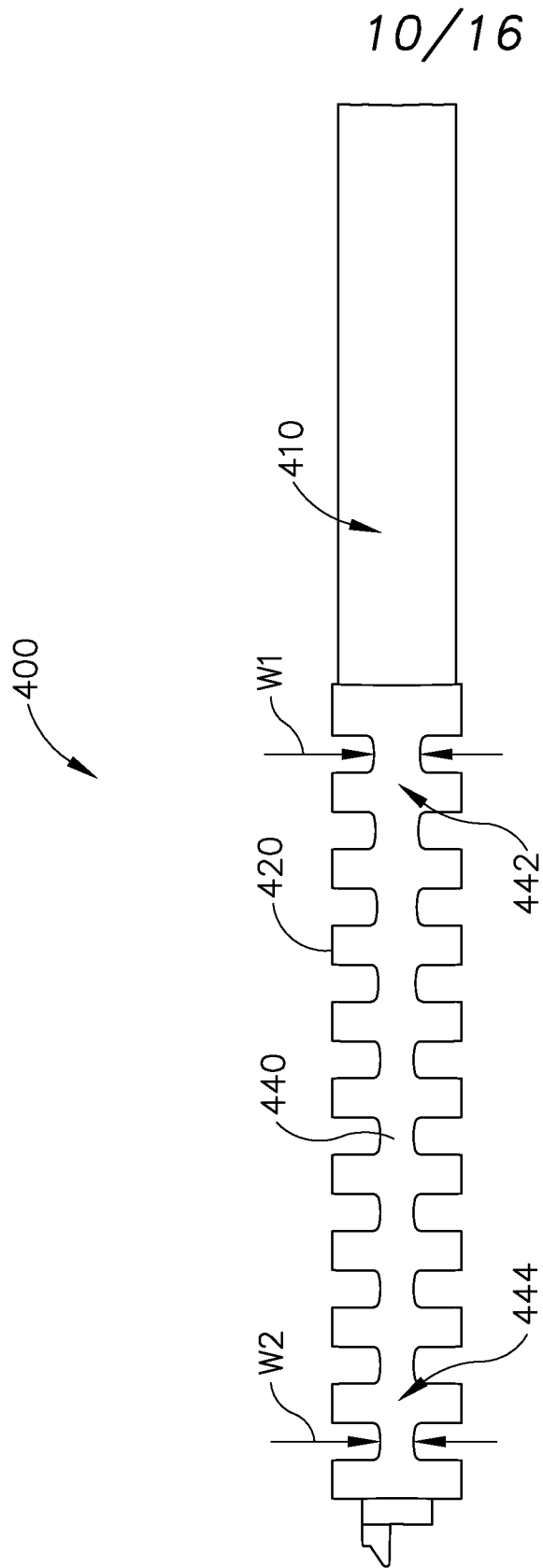

Fig. 13

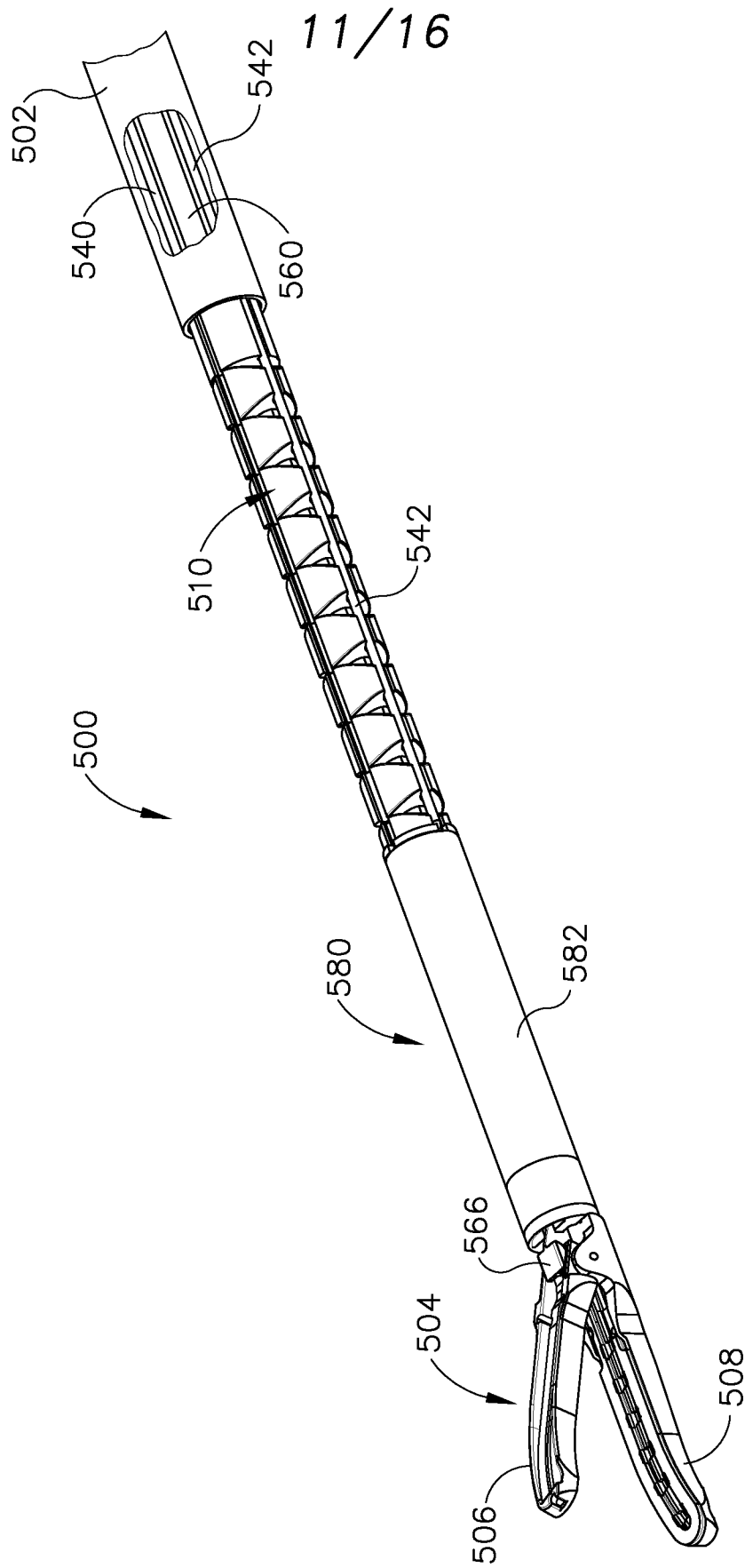

Fig. 14

12/16

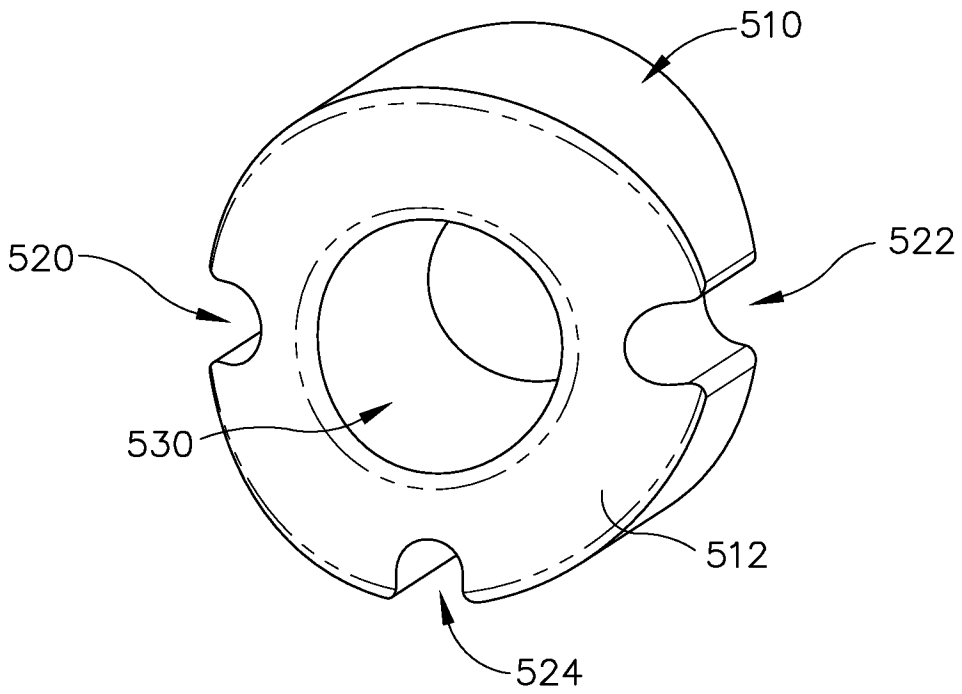

Fig. 15

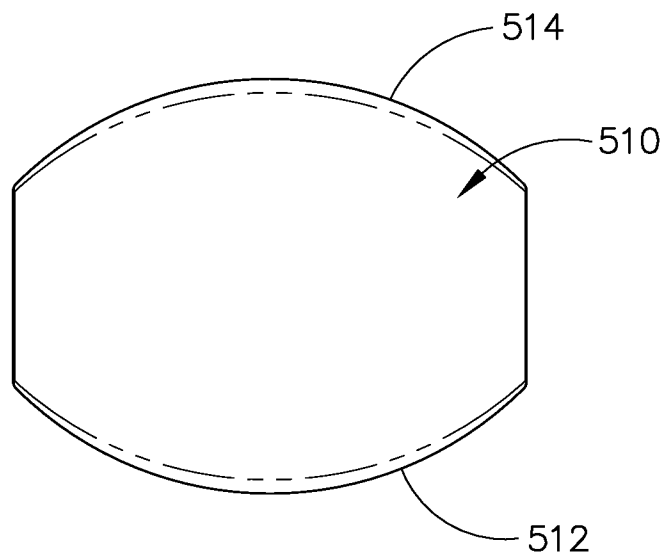

Fig. 16



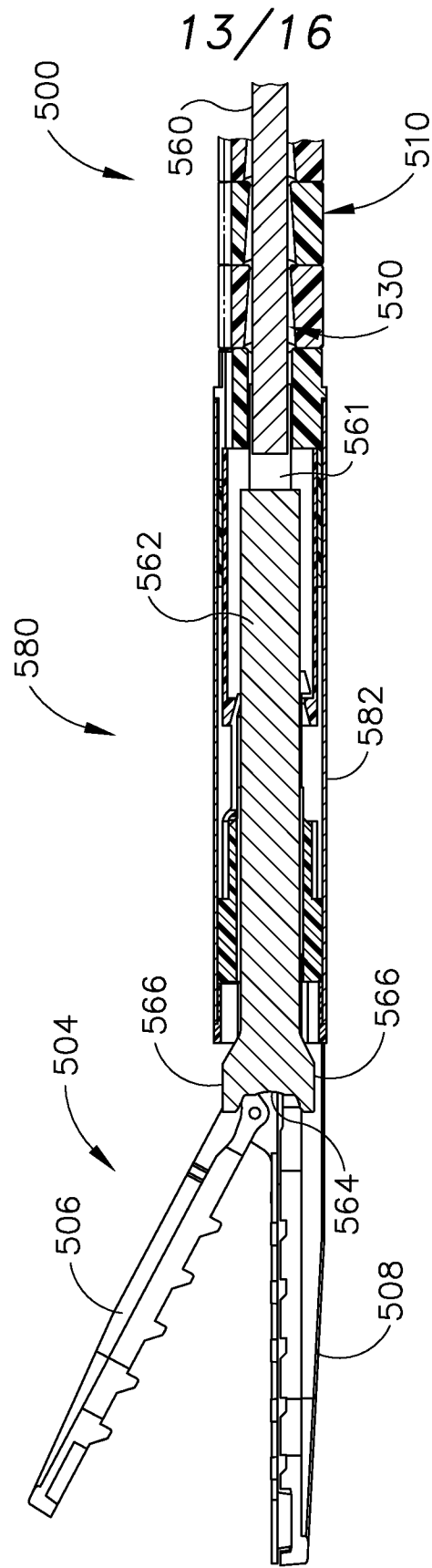

Fig.17

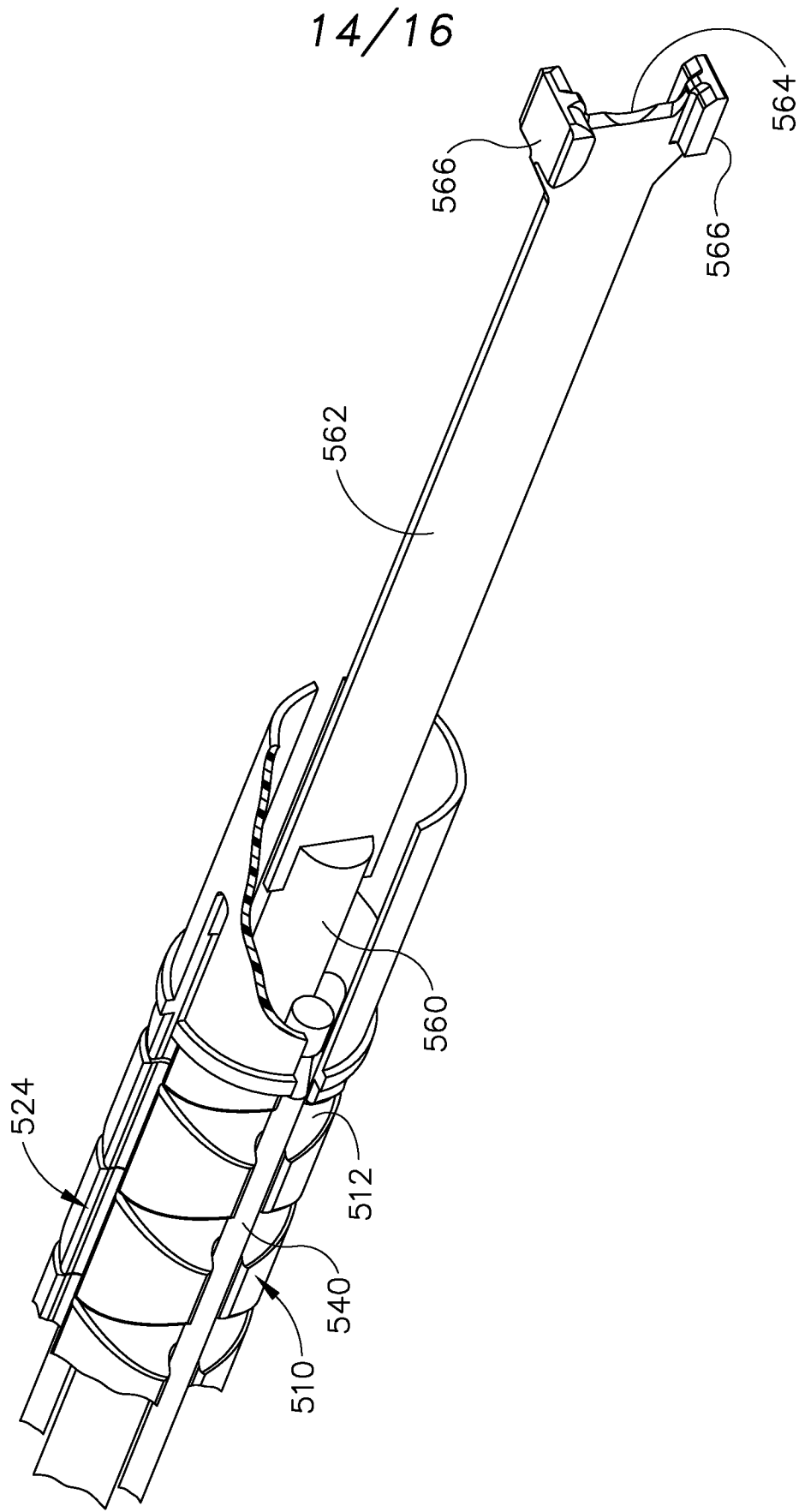

Fig. 18

15/16

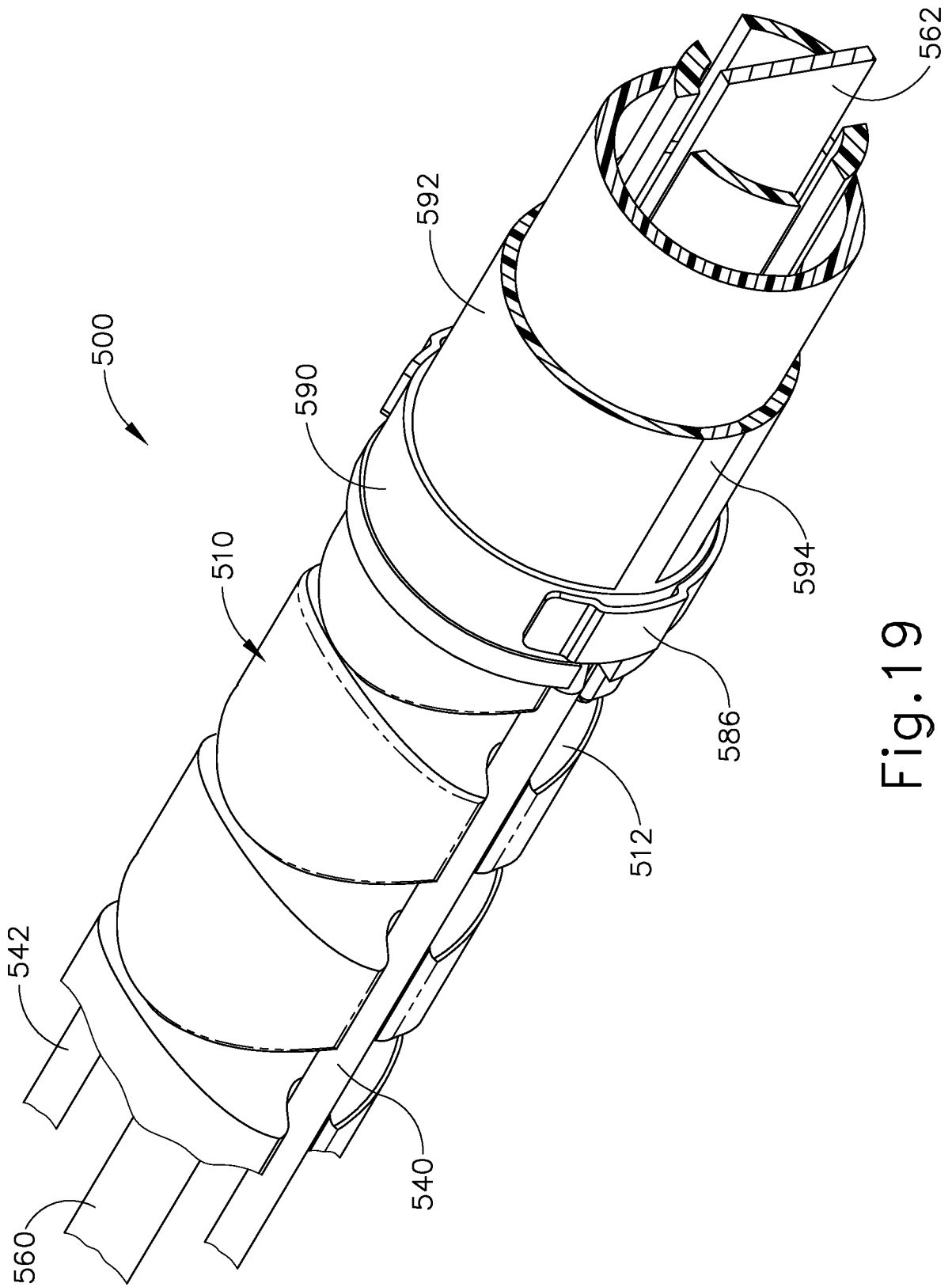

Fig. 19

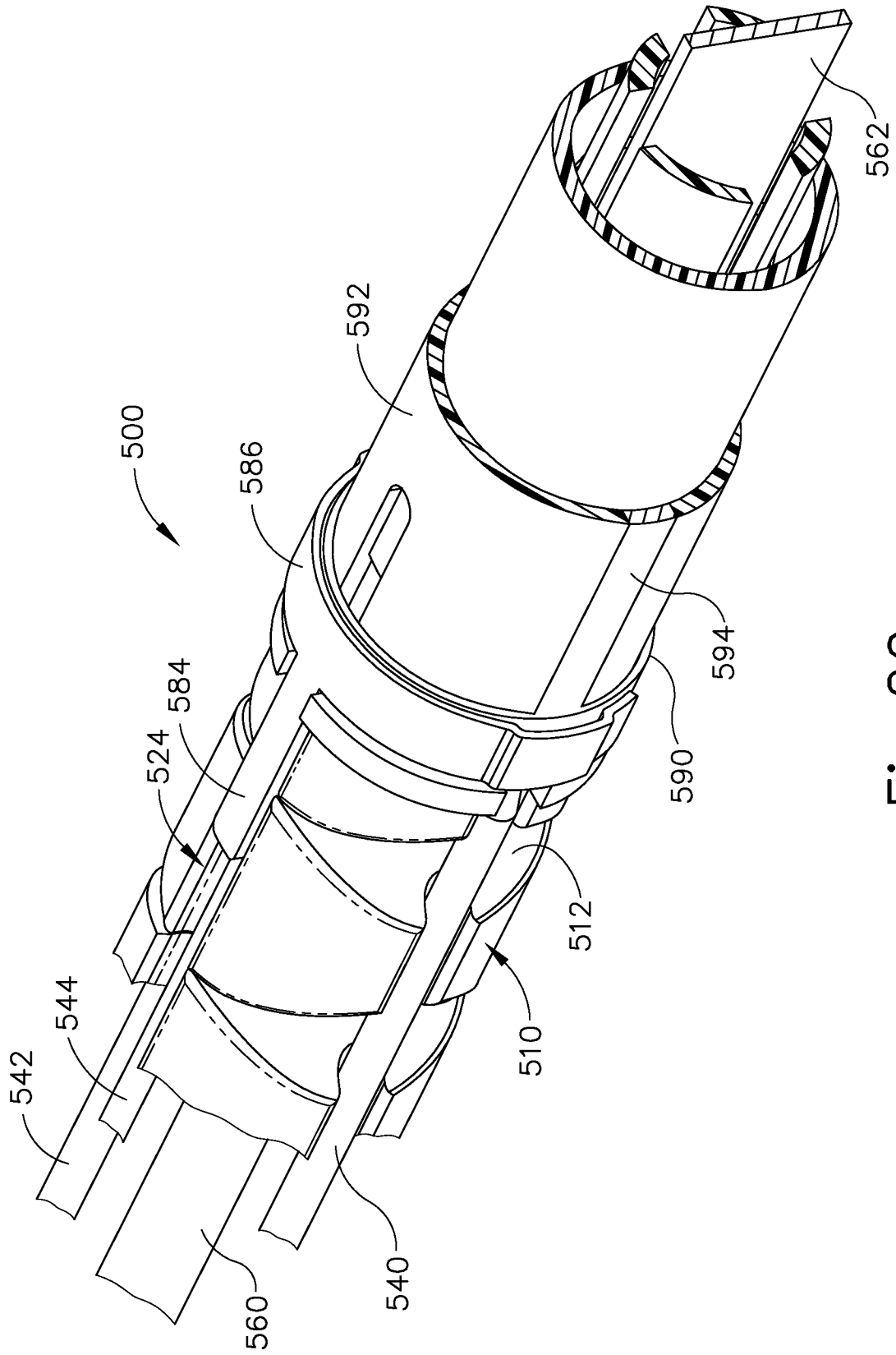

Fig. 20

## INTERNATIONAL SEARCH REPORT

International application No

PCT/US2011/052723

**A. CLASSIFICATION OF SUBJECT MATTER**

INV. A61B18/14  
ADD.

According to International Patent Classification (IPC) or to both national classification and IPC

**B. FIELDS SEARCHED**

Minimum documentation searched (classification system followed by classification symbols)

A61B

Documentation searched other than minimum documentation to the extent that such documents are included in the fields searched

Electronic data base consulted during the international search (name of data base and, where practical, search terms used)

EPO-Internal, WPI Data

**C. DOCUMENTS CONSIDERED TO BE RELEVANT**

Category*	Citation of document, with indication, where appropriate, of the relevant passages	Relevant to claim No.
X	EP 2 151 204 A1 (TYCO HEALTHCARE [US]) 10 February 2010 (2010-02-10) abstract; figures 1,3,5,8,10a,11d,23,32,33,47 paragraphs [0005], [0080], [0082] - [0084], [0087], [0092], [0107], [0115], [0129], [0134] - [0137] -----	1-13, 15-18,20
X	US 2010/179540 A1 (MARCZYK STANISLAW [US] ET AL) 15 July 2010 (2010-07-15) abstract; figures 1a,8,21 paragraphs [0020], [0103], [0121], [0125], [0177], [0193] -----	1-13,15, 16,19,20
X	EP 1 637 086 A1 (SHERWOOD SERV AG [CH] COVIDIEN AG [CH]) 22 March 2006 (2006-03-22) the whole document -----	1-13,15, 16,20
	-/--	

Further documents are listed in the continuation of Box C.

See patent family annex.

\* Special categories of cited documents :

"A" document defining the general state of the art which is not considered to be of particular relevance

"E" earlier document but published on or after the international filing date

"L" document which may throw doubts on priority claim(s) or which is cited to establish the publication date of another citation or other special reason (as specified)

"O" document referring to an oral disclosure, use, exhibition or other means

"P" document published prior to the international filing date but later than the priority date claimed

"T" later document published after the international filing date or priority date and not in conflict with the application but cited to understand the principle or theory underlying the invention

"X" document of particular relevance; the claimed invention cannot be considered novel or cannot be considered to involve an inventive step when the document is taken alone

"Y" document of particular relevance; the claimed invention cannot be considered to involve an inventive step when the document is combined with one or more other such documents, such combination being obvious to a person skilled in the art.

"&" document member of the same patent family

Date of the actual completion of the international search

19 January 2012

Date of mailing of the international search report

01/02/2012

Name and mailing address of the ISA/

European Patent Office, P.B. 5818 Patentlaan 2  
NL - 2280 HV Rijswijk  
Tel. (+31-70) 340-2040,  
Fax: (+31-70) 340-3016

Authorized officer

Pereda Cubián, David

**INTERNATIONAL SEARCH REPORT**

International application No  
PCT/US2011/052723

C(Continuation). DOCUMENTS CONSIDERED TO BE RELEVANT		
Category*	Citation of document, with indication, where appropriate, of the relevant passages	Relevant to claim No.
X	WO 2010/104755 A1 (TYCO HEALTHCARE [US]; MARCZYK STANISLAW [US]; PRIBANIC RUSSELL [US]) 16 September 2010 (2010-09-16) the whole document -----	1-13,15, 16,19,20
X	WO 2008/045348 A2 (TYCO HEALTHCARE [US]; TAYLOR ERIC J [US]; HATHAWAY PETER [US]) 17 April 2008 (2008-04-17) the whole document -----	1-13,15, 16,19,20
X	US 2010/179545 A1 (TWOMEY JOHN R [US] ET AL) 15 July 2010 (2010-07-15) the whole document -----	1-16,19, 20

## INTERNATIONAL SEARCH REPORT

International application No

PCT/US2011/052723

Patent document cited in search report	Publication date	Patent family member(s)	Publication date
EP 2151204	A1	10-02-2010	AU 2009203208 A1 18-02-2010
			CA 2674520 A1 04-02-2010
			CN 101849846 A 06-10-2010
			EP 2151204 A1 10-02-2010
			JP 2010036039 A 18-02-2010
			US 2010030018 A1 04-02-2010
-----			
US 2010179540	A1	15-07-2010	NONE
-----			
EP 1637086	A1	22-03-2006	AU 2005211626 A1 06-04-2006
			CA 2520408 A1 21-03-2006
			EP 1637086 A1 22-03-2006
			EP 2248481 A2 10-11-2010
			ES 2349468 T3 03-01-2011
			US 2006064085 A1 23-03-2006
			US 2009018535 A1 15-01-2009
			US 2010312238 A1 09-12-2010
-----			
WO 2010104755	A1	16-09-2010	EP 2403421 A1 11-01-2012
			WO 2010104755 A1 16-09-2010
-----			
WO 2008045348	A2	17-04-2008	AU 2007307082 A1 17-04-2008
			AU 2007307084 A1 17-04-2008
			CA 2664111 A1 17-04-2008
			CA 2664167 A1 17-04-2008
			CN 101522127 A 02-09-2009
			CN 101522128 A 02-09-2009
			EP 2081512 A2 29-07-2009
			EP 2086439 A2 12-08-2009
			JP 2010505521 A 25-02-2010
			JP 2010505522 A 25-02-2010
			US 2010076433 A1 25-03-2010
			US 2010094289 A1 15-04-2010
			WO 2008045348 A2 17-04-2008
			WO 2008045350 A2 17-04-2008
-----			
US 2010179545	A1	15-07-2010	NONE
-----			