

No. 854,325.

PATENTED MAY 21, 1907.

H. F. BELCHER.  
DESK RULER.

APPLICATION FILED DEC. 19, 1906.

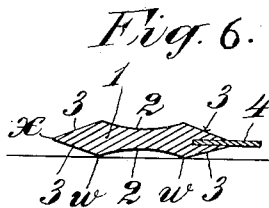
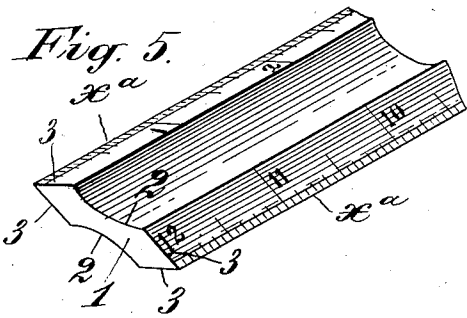
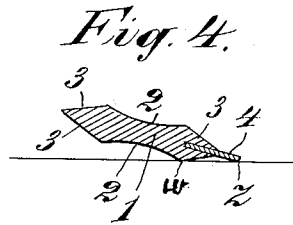
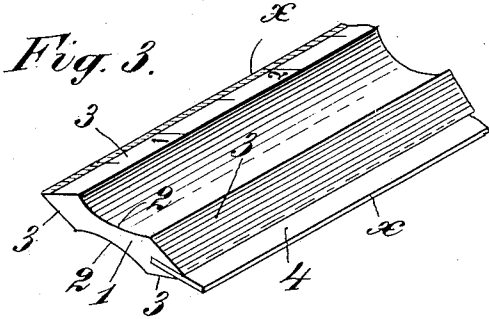
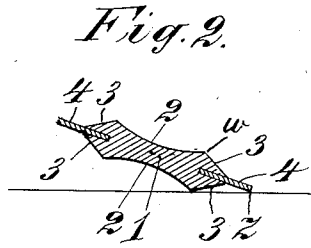
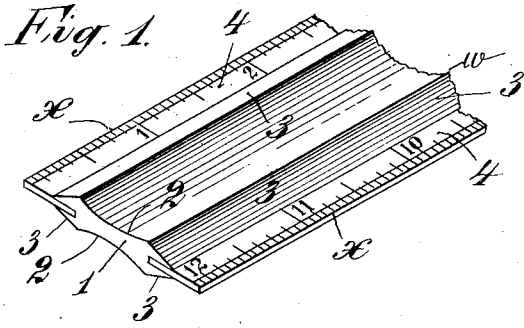

Witnesses  
J. H. Klineau  
William J. Firth

H. F. Belcher  
Inventor  
By his Attorney, Henry Bennett

# UNITED STATES PATENT OFFICE.

HENRY F. BELCHER, OF IRVINGTON, NEW JERSEY, ASSIGNOR TO THE  
BELCHER BROTHERS COMPANY, OF NEW YORK, N. Y.

## DESK-RULER.

No. 854,325.

Specification of Letters Patent.

Patented May 21, 1907.

Application filed December 19, 1905. Serial No. 292,454.

To all whom it may concern:

Be it known that I, HENRY F. BELCHER, a citizen of the United States, residing at Irvington, in the county of Essex and State of New Jersey, have invented certain new and useful Improvements in Desk-Rulers, of which the following is a specification.

This invention relates to certain improvements in rulers, and more particularly in that class of such devices commonly termed desk rulers and which are of elongated flattened formation, and the object of the invention is to provide a device of this character of a comparatively simple and inexpensive nature which shall be neat and attractive in appearance, strong in construction and capable of convenient and improved use.

The invention consists in certain novel principles and features of the construction, and combinations and arrangements of the several parts of the improved ruler, whereby certain important advantages are attained, and the device is rendered simpler, cheaper and otherwise better adapted and more convenient for use, all as will be hereinafter fully set forth.

The novel features of the invention will be carefully defined in the claims.

In the accompanying drawings which serve to illustrate my invention—Figure 1 is a fragmentary perspective view showing a ruler embodying my improvements; Fig. 2 is a cross section taken through the ruler as seen in Fig. 1 and showing the same tilted or inclined to bring its graduated or fiducial edge portion into contact with a desired surface; Fig. 3 is a perspective view similar to Fig. 1, but illustrating a modified formation of the improved ruler; Fig. 4 is a cross section similar to Fig. 2, but illustrating the modified formation shown in Fig. 3; Fig. 5 is another perspective view similar to Figs. 1 and 3 and illustrating another modified formation of the improved ruler; Fig. 6 is a cross section similar to Fig. 4, but illustrating the modified formation seen in Figs. 3 and 4 rested flat upon a desired surface.

Referring primarily to Figs. 1 and 2, the improved ruler comprises a body portion 1 which may be made of wood or other material in elongated form and of a general flattened formation in cross section so as to be adapted to rest readily upon its opposite

flattened sides while its opposite edges are made thin so as to permit of convenient handling and use in ruling, measurement, and the like.

The opposite flattened faces 2, 2 of the improved ruler are not formed of plane surfaces, but are made concave, and the axes of their curvatures are extended lengthwise of the central portion of the ruler so that central depressions are produced extended lengthwise along said opposite faces of the ruler as clearly shown in the drawings.

Along the opposite edges of the ruler, and upon each of the wider side surfaces thereof, are produced reversely extended beveled surfaces 3, 3, the said surfaces at opposite edges of each side face of the ruler meeting the outer parts of the central longitudinal depression or concave surface 2, therein at angles, as seen at *w, w* in Figs. 1 and 2, so as to form projections or flanges along opposite edge portions of each lateral face or side of the ruler, and which, when the ruler is laid flat upon a desired surface, as indicated in Fig. 6, are adapted to contact therewith while the intervening concave surfaces 2 and the beveled exterior surfaces 3, 3 at opposite sides thereof, and which are extended in planes at angles to each other and to said concave surface 2, are supported out of contact with such surface, so that the improved ruler is adapted to be more readily and conveniently passed over a book or other article to be ruled or measured and is not likely to be caught or impeded by unevenness of the supporting surface.

The beveled surfaces 3, 3, at each edge portion of the improved ruler and on opposite side or lateral surfaces thereof are also extended at angles to each other so as to be adapted to meet along a line central and longitudinally extended at each edge of the body portion, and at the juncture of the said opposite beveled surfaces 3, 3 at each edge of the ruler, a thin metallic strip *x* is inserted in a well known way, forming a reinforce at such edge to prevent marring thereof, and said strip may, if desired be provided with suitable graduations as indicated in Fig. 1.

The thin metal strip or reinforce 4, at each edge of the improved ruler is extended in a plane at angles to each of the beveled faces 3, 3, at the juncture of which said strip is in-

serted, and the outer edge of each such strip 4 is extended beyond the point of juncture of such adjacent beveled surfaces 3, 3, so as to be adapted, when the ruler is tilted upon a desired supporting surface as shown in Fig. 2, for contact therewith, in such manner as to act in conjunction with the angular projection *w*, produced at the juncture of the lower-most beveled surface 3 with the lower-most concave surface 2, to hold the said lowermost beveled surface 3 from contact with the supporting surface whereby the ruler may be more readily passed over a book or other supporting surface and such movement of the ruler will not be impeded by irregularities or unevenness in the supporting surface.

In Figs. 3 and 4 I have shown a formation of the improved ruler similar to that above described except that the metal strip 4 is omitted at one edge of the ruler, and in Fig. 5 I have shown a similar formation wherein the metal strips are omitted from both edges of the ruler.

The improved ruler constructed according to my invention is of an extremely simple and comparatively inexpensive nature and is particularly well adapted for use by reason of the provision of the longitudinally extended projections which materially increase the convenience of its use by lessening the likelihood of catching of the ruler when passed over uneven surfaces, and also afford strength and rigidity so as to prevent breakage or warping of the device.

Having thus described my invention, what I claim and desire to secure by Letters Patent is—

1. A ruler having upon its lateral face a central longitudinally extended depression and provided with longitudinally extended non-alined edge surfaces which meet the opposite sides of said central depression at angles forming longitudinally extended projections along opposite sides of said depression and whereon the ruler is adapted to be supported with said edge surfaces and the

surface within the said depression out of contact with a supporting surface.

2. A ruler having upon its lateral face a central longitudinally extended depression, and provided with longitudinally extended edge surfaces at angles to each other and which meet the opposite sides of said central depression at angles forming longitudinally extended projections along opposite sides of said central depression, and whereon the ruler is adapted to be supported with said edge surfaces and the surface within said depression out of contact with a supporting surface.

3. A ruler having upon each of its opposite lateral faces a central longitudinally extended depression, and provided at opposite sides of each such depression with longitudinally extended edge surfaces at angles to each other and which meet the opposite sides of the intervening depression at angles forming longitudinally extended projections along opposite sides of said central depression and whereon the ruler is adapted to be supported with said edge surfaces and the surfaces within said depressions out of contact with a supporting surface.

4. A ruler having surfaces adapted to meet at angles along its edge, and terminating, opposite to their junctures, in projections extended lengthwise of the ruler, and a metallic strip held to the ruler at the juncture of said angular edge surfaces, and having an edge portion extended beyond the point of juncture of said angular edge surfaces of the ruler and adapted for contact with a support on which the ruler is rested, to maintain the ruler with its lowermost angular edge surface out of contact with such support.

In witness whereof I have hereunto signed my name this 14th day of December 1905, in the presence of two subscribing witnesses.

HENRY F. BELCHER.

Witnesses:

MARY EMMA KEENE,  
WILLIAM PRITCHARD.