

(19)



Europäisches Patentamt  
European Patent Office  
Office européen des brevets



(11)

**EP 1 498 042 B1**

(12)

**EUROPEAN PATENT SPECIFICATION**

(45) Date of publication and mention  
of the grant of the patent:  
**03.05.2006 Bulletin 2006/18**

(51) Int Cl.:  
**A43D 25/047<sup>(2006.01)</sup> A43D 25/18<sup>(2006.01)</sup>**  
**A43D 119/00<sup>(2006.01)</sup>**

(21) Application number: **03425467.2**

(22) Date of filing: **14.07.2003**

(54) **Machine for production of footwear**

Maschine zur Herstellung von Schuhwerken

Machine pour la fabrication d'articles chaussants

(84) Designated Contracting States:  
**CZ ES FR IT RO**

(43) Date of publication of application:  
**19.01.2005 Bulletin 2005/03**

(73) Proprietor: **OFFICINE MECCANICHE MOLINA &  
BIANCHI S.p.A.**  
**27029 Vigevano (Pavia) (IT)**

(72) Inventor: **Bianchi, Carlo**  
**27025 Gambolo' (PV) (IT)**

(74) Representative: **Simino, Massimo et al**  
**Perani Mezzanotte & Partners**  
**Piazza S. Babila, 5**  
**20122 Milano (IT)**

(56) References cited:  
**EP-A- 0 118 243 EP-A- 1 036 516**  
**US-A- 4 608 723**

**EP 1 498 042 B1**

Note: Within nine months from the publication of the mention of the grant of the European patent, any person may give notice to the European Patent Office of opposition to the European patent granted. Notice of opposition shall be filed in a written reasoned statement. It shall not be deemed to have been filed until the opposition fee has been paid. (Art. 99(1) European Patent Convention).

## Description

**[0001]** The present invention relates to a machine for production of footwear in accordance with the preamble of claim 1.

**[0002]** As is known, in the production of footwear the upper is glued onto the insole. For this purpose, the upper is applied and stretched on a footwear last, with the base of which an insole has previously been associated. Subsequently, after having spread glue on the contour of the insole, the edges of the upper are folded and pressed onto the insole, such as to obtain the required gluing.

**[0003]** According to the known art, the above-described operations are carried out in the footwear industry automatically by using pre-assembly machines in which the operation of adding the glue is carried out using different methods.

**[0004]** The use of machines which can carry out these operations automatically is advantageous from the points of view both of the high production volumes which these machines make it possible to obtain, and the constant quality of the products obtained, which these machines succeed in assuring.

**[0005]** The requirement which these machines must fulfil consists of succeeding in adapting to the different shapes and dimensions of existing insoles. In this respect it is necessary to take into consideration that for insoles of the same size, there can be models which have different shapes and fittings (for example narrow or wide).

**[0006]** In order to obtain satisfactory gluing of the upper to the insole, the glue must be well supplied at the contour of the insole. Thus, it is apparent that as the shape of the insole varies, the means provided for supplying the glue must be able to supply the glue at the points required, independently of the shape of the insole.

**[0007]** Account must also be taken of the fact that the glue supplying must be limited only to the portions of the insole which are designed to be glued onto the upper, i.e. along the contour of the insole. In fact, the presence of glue outside these portions is undesirable in the subsequent processing operations to which the upper must be subjected.

**[0008]** A machine which can carry out the above-described operation is known, for example, from patent application EP-A-1036516. In the machine according to the known art, the glue is added in the front part of the insole by means of a supplier plate which is provided with a plurality of suppliers at the rear part of the insole, by means of two movable suppliers, in order to follow the contour of the remaining part of the insole.

**[0009]** The patent also specifies that when the shape and dimension of the insoles varies, the plate can adapt to the profile of the front part of the insole, whereas the two suppliers follow the contour of the insole starting from the plate.

**[0010]** Although the solution proposed in patent application EP-A-1036516 is designed for insoles which have different shapes and dimensions, it is not satisfactory for

applying the glue onto an insole when the front part of the insole has a pointed or blunt shape, as it is known.

**[0011]** In order to eliminate this disadvantage, machines have been proposed for production of footwear, wherein the glue is added by means of two movable suppliers, in order to supply the glue along the contour of the insole, as far as the front end of the insole itself.

**[0012]** However these machines also have problems relating to the uniformity of glue supplying and the pressure of the insole against the sole of the footwear last. In particular, when the footwear last is extremely pointed, the movable suppliers cannot supply the glue regularly along the contour of the insole, particularly at the edges of the tip of the insole. In addition, if the insole is extremely thin, the pressure exerted by the suppliers is insufficient to maintain the tip of the insole pressed firmly against the base of the footwear last, when the suppliers are released from the insole in order to permit folding of the upper onto the insole.

**[0013]** The problem on which the present invention is based consists of devising a machine for production of footwear, which has characteristics such as to fulfil the above-described requirements and simultaneously to eliminate the disadvantages described with reference to the known art.

**[0014]** This problem is solved by a machine for production of footwear according to claim 1.

**[0015]** Further characteristics and the advantages of the machine according to the present invention will become apparent from the following description, provided by way of non-limiting indication, with reference to the appended figures, in which:

- figure 1 represents a schematic perspective view of a machine according to the invention;
- figures 2-5 represent schematic perspective views of the glue supplier means of the machine in figure 1, in different positions assumed during operation of the machine;
- figure 6 represents a schematic view of the glue supplier plate of the machine 1 in different positions assumed during operation of the machine;
- figures 7-9 represent schematic views of the glue supplier means of the machine in figure 1 according to a first operating mode of the machine;
- figures 10-12 represent schematic views of the glue supplier means of the machine in figure 1 according to a second operating mode of the machine;
- figure 13 represents a perspective view of a footwear last with which the upper and the insole are associated; and
- figures 14 to 18 represent plan views of an insole

during different stages of the operating cycle of the machine 1.

**[0016]** With reference to the appended figures, 1 indicates as a whole a machine for pre-assembly and assembly of an upper 21 on a footwear last 2. With the sole 15 of the last 2 there is associated a footwear insole 23 which extends between a rear end 32 and a front end 31.

**[0017]** The machine 1 comprises a support frame 3, to which there are secured positioning means 5 which are designed to support the last 2 at its tip 6.

**[0018]** In the example, the positioning means 5 take the form of a support element 4 which has a flat triangular surface with a limited size, on which the last 2 is designed to be positioned in a supported manner.

**[0019]** The support element 4 is inclined such that the line Z-Z perpendicular to its flat triangular surface coincides substantially with the line of view of an operator who is observing the surface itself, and is standing in front of the machine 1 (at the point indicated by 0 in figure 1).

**[0020]** The machine 1 comprises an upper thruster 7, two lateral thrusters, both of which are indicated by 8, and a rear thruster 9. These thrusters are designed to engage respectively with the back 10, with the sides 11 and with the heel 12 of the last 2, in order to maintain the last itself in pressure contact against the triangular surface of the support element 4, in an operative working position (Figures 3-5).

**[0021]** It should be noted that in the figures, for the sake of simplicity, there are not shown the support element 4 or other elements which are not essential for the purposes of understanding the operation of the machine according to the present invention, but are necessary in order for it to operate.

**[0022]** A plurality of grippers, all of which are indicated by 13, are disposed around the support element 4, such as to face the contour of the tip 6 of the footwear last 2. In a conventional known manner, the opening and closure of the grippers 13 is controlled, and they are displaced individually as required in order to obtain the desired tensioning of the upper 21 on the footwear last 2, before the gluing is carried out.

**[0023]** The machine 1 also comprises means which are indicated as 14 as a whole, in order to fold the edges of the upper 21 towards the sole 15 of the footwear last 2, after opening of the grippers 13, as well as means, not shown in the figures, to press the folded edges of the upper 21 from beneath, against the insole 23, along its contour which is provided with glue 24.

**[0024]** In the example illustrated, the means 14 for folding the edges of the upper 21 comprise two arched plates 17, which reproduce the profile of the contour of the tip 6 of the footwear last 2 and are movable towards the last itself.

**[0025]** The machine 1 comprises means for supplying the glue 24 onto the insole 23. These means comprise a glue supplier plate 19 which has a plurality of nozzles

20 and one or more glue suppliers 22, of which there are two in the example.

**[0026]** The supplier plate 19 is positioned in the vicinity of the support element 4, and is shaped specifically such as to follow the profile of the front portion of a footwear last. According to a preferred embodiment, the supplier plate 19 is associated with an underlying support plate 28, by means of securing elements which are not shown in the figures.

**[0027]** Advantageously, but not necessarily, the supplier plate 19 can comprise a plurality of pieces which are connected to one another such as to be articulated as described, for example, in European patent application EP-1036516.

**[0028]** With the nozzles 20 of the plate 19 there are associated electrical resistors which make it possible to heat the glue such as to make it fluid and facilitate its supplying.

**[0029]** By means of activation means 40, the supplier plate 19 is movable between a rest position which is spaced from the last 2, and an operative position in which the plate 19 is in contact with the footwear last 2, and specifically with the insole 23 applied to the sole 15, in order to supply the glue along the contour 27 of the front portion of the insole 23. In other words, the supplier plate 19 makes it possible to supply the glue at the tip 6 of the footwear last 2. In particular, the plate 19 has a surface portion 19a which can be associated with the insole 23 during the glue supplying.

**[0030]** Preferably the said activation means 40 do not act directly on the supplier plate 19, but on the support plate 28.

**[0031]** By means of activation means 41, the suppliers 22 are movable between a rest position and an operative position in which they engage from beneath with the footwear last 2, and in particular with the insole 23 applied to the sole 15, in order to supply the glue 24 along the contour 27 of the insole 23.

**[0032]** In particular, the suppliers 22 are movable, i.e. they are supported by the frame 3 of the machine 1 such as to be able to move along the contour 27 of the insole 23. In other words, the suppliers 22 make it possible to follow the sides of the insole 23 in order to supply the glue 24 along the latter.

**[0033]** According to a preferred embodiment, the suppliers 22 are associated with a support element 33, on which there act the activation means 41 which move the suppliers 22 such that the latter move along the contour 27 of the insole 23, starting from the rear part of the insole 23.

**[0034]** Preferably, the suppliers 22 are supplied with a thermoplastic thread of glue (not represented in the figures), and end in a roller which makes it possible to spread the glue 24 supplied along the contour 27 of the front portion of the insole 23.

**[0035]** Advantageously, with the suppliers 22 there are associated electrical resistors which make it possible to heat the thermoplastic thread of glue until it becomes an

adhesive fluid.

**[0036]** The activation means 40, 41 can comprise for example hydraulic actuators, step-by-step electric motors or other conventional means which are normally used to automate the movement of two or more parts. In addition, the machine 1 can be provided with command and control means in order to control the operation of the said activation means 40, 41, i.e. in order to control the movement respectively of the plate 19 and the suppliers 22 from the rest position to the operative position.

**[0037]** Advantageously, the rest position of the supplier plate 19 is such as to permit advance of the suppliers 22 as far as the front end 31 of the insole 23, without giving rise to interference between the supplier plate 19 and the suppliers 22 themselves. In particular, the rest position of the supplier plate 19 permits advance of the suppliers 22 as far as the front end 31 of the insole 23, such that the suppliers 22 are above the supplier plate 19.

**[0038]** Preferably, the plate 19 is displaced from the operative position to the rest position spaced from the footwear last 2, by means of translation movement parallel to the said direction Z-Z (figure 1).

**[0039]** Preferably, the support plate 28 is associated with a telescopic guide 42 which is movable in order to obtain displacement of the plate 19 between the rest position and the operative position and vice versa. In the example shown in the figures, the guide 42 is extended according to a straight axis parallel to the said direction Z-Z (figure 1), and is movable in this direction.

**[0040]** Activation means, not illustrated in the figures, are associated with the telescopic guide 42.

**[0041]** Alternatively, the support plate 28 can be supported by a sliding runner on a guide which extends in the direction Z-Z. The slide is then activated by drive means in order to control the movement of the slide along the guide.

**[0042]** In the rest position, the distance between the upper surface 19a of the plate 19 and the insole 23, measured along the axis Z-Z, is 10 cm or more, preferably between 10 cm and 13 cm, for example 11,5 cm.

**[0043]** The aforementioned values are provided by way of example with reference to a typical machine for production of footwear. It is apparent that these values can vary according to the dimension of the plate 19, the size of the suppliers 22, and the general dimension of the machine 1 for production of footwear.

**[0044]** According to a preferred embodiment, the plate 19 can stop in an intermediate position (I) between the rest position (R) and the operative position (O). At each actuation cycle of the machine, when use of the supplier plate 19 is required, this makes it possible to prevent long pause times which are necessary in order to displace the plate 19 from the rest position spaced from the last 2, to the operative position for supplying the glue, onto the insole 23.

**[0045]** In fact, since in the intermediate position (I) the distance between the portion of surface 19a of the plate 19 and the insole 23, measured along the axis Z-Z, is

short (in the example concerned it is between 2 cm and 3 cm, preferably 2,5 cm), and is substantially shorter than the distance between the spaced rest position and the operative position for supplying, the time taken by the supplier-plate 19 to go into the operative position for supplying (figure 11) is very short.

**[0046]** The supplier plate 19 is supplied with a thermoplastic thread of glue (shown in a broken line in the figures). Advantageously, with the supplier plate 19 there are associated electrical resistors which make it possible to heat the thermoplastic thread of glue such as to transform it into a fluid which can be supplied by means of the nozzles 20. The thread of thermoplastic material can be of the same type as that used for the suppliers 22.

**[0047]** The electrical resistors of the plate 19 are supplied by a supply cable which extends inside the telescopic guide 42. The supplier plate 19 comprises a temperature sensor which is connected by means of an electric wire to a control unit.

**[0048]** The supply cable and the electric wire of the sensor are slack, i.e. slightly longer than necessary, in order to be able to follow the plate 19 in its movement between the rest position and the operative position. As far as the thread of thermoplastic glue is concerned, there are no problems in following the movement of the supplier plate 19 and support 28, since this thread is supplied continuously.

**[0049]** Advantageously, the telescopic guide 42 consists of tubular elements inside which there pass the supply cable for the resistors of the plate 19, the electric wire of the temperature sensor, and the thread of thermoplastic glue.

**[0050]** When the machine 1 is operating, the footwear last 2 is supported in the support element 4. Subsequently, the thrusters 7, 8 and 9 fix the last 2 in its work position. By means of the grippers 13, tensioning of the upper 21 is pulled on the footwear last 2.

**[0051]** The operation of the supplying means is described starting with an initial situation in which the supplier plate 19 and the suppliers 22 are in the rest position and are ready to receive the commands from the command and control means.

**[0052]** In particular, the following description relates to operation of the machine 1 for gluing the upper to insoles which have medium to high rigidity and/or a tapered tip. In this case, the glue can advantageously be supplied solely by using the suppliers 22.

**[0053]** Figures 2 and 6 show the plate 19 and the suppliers 22 in a rest position (R).

**[0054]** If on the other hand the supplier plate 19 is in the intermediate position (I) between the rest position and the operative position (O) (fig. , the supplier plate 19 must be moved downwards, taking it from the intermediate position (I) to the rest position (O), such as to permit advance of the suppliers 22.

**[0055]** At this point, by means of the activation means 41, which are controlled by the command and control means, the suppliers 22 are advanced from the rest po-

sition to the operative position, such as to carry out glue supplying along respective portions of the contour of the insole 23 (figures 14-18).

**[0056]** Figure 3 and figures 7 to 9 show the movement of the suppliers 22 in the operative position and the plate 19 in the rest position (R).

**[0057]** The suppliers 22 are able to move along the said portions of the contour of the insole 23 such as to follow a path previously stored, and to remain constantly pressed against the insole 23. By this means, the suppliers 22 keep the insole 23 pressed against the sole 15 of the last 2.

**[0058]** In particular, the rest position assumed by the plate 19 allows the suppliers 22 to advance towards the front end 31 of the insole 23, without interference occurring between the supplier plate 19 and the suppliers 22. If this were not the case, i.e. if the plate 19 were in the intermediate position or in the operative position, the suppliers 22 could supply the glue along the contour 27 of the insole 23 only as far as in the vicinity of the plate 19, the presence of which would prevent further advance of the suppliers 22 towards the front end 31 of the insole 23.

**[0059]** On completion of the phase of supplying the glue 24, a supplier 22 is released from the insole 23 at a detachment point 29 which is positioned in the vicinity of the front end 31 of the insole 23, thus allowing only the remaining supplier 22 to continue as far as the front end of the tip of the insole (figures 14-18). Once the remaining supplier 22 also reaches the front end of the tip of the insole, the latter is released from the insole 23, and both the suppliers 22 return to the rest position.

**[0060]** There are preferably at least two suppliers 22, such -that each supplier can supply the glue 24 along a respective and distinct portion 26 of the insole 23.

**[0061]** In particular-, the portions 26 determine the contour 27 of the insole 23 along which the glue 24 is applied.

**[0062]** The suppliers 22 are thus movable along respective portions 26 of the contour 27 of the insole 23 which determine the said predetermined path. The path, which is variable according to the shape of the insole 23, is stored in order to control automatically the movement of the suppliers themselves.

**[0063]** Supplying the glue 24 onto the insole 23 is advantageously carried out starting from the rear part of the insole 23 towards the front end 31 of the insole 23, as shown in figure 3.

**[0064]** If the front end 31 of the insole 23 is tapered, on completion of the phase of supplying the glue 24, the two suppliers 22 are both released from the insole 23 at a detachment point 29 which is located in the vicinity of the front end 31 of the insole 23. In particular, each supplier will pass via this point 29 at successive temporal moments, such as to prevent interference with the other supplier.

**[0065]** Alternatively, on completion of the phase of supplying the glue 24, a first supplier is released from the insole 23 at a first point 29 which is located in the vicinity of the front end 31, whereas the other supplier is released

at a second point 30 which is located at a predetermined distance from the first point 32, so as not to interfere with the first supplier.

**[0066]** According to the said embodiment, the detachment points 29 and 30 -are disposed aligned with one another according to a longitudinal axis A-A of the insole 23, which passes via the front end 31 of the insole 23.

**[0067]** The points 29 and 30 are indicated in the figures by way of non-limiting example, thus allowing for the possibility of modifying the position of release of the suppliers 22 according to the different design requirements and the different shapes of the insole 23.

**[0068]** If the glue must be applied onto a footwear last which has an extremely pointed front profile and/or the insole is not very rigid, it is necessary to intervene with an appropriately-shaped supplier plate 19. In fact, in this case, the use of the suppliers 22 alone is not satisfactory in terms of uniformity of glue supplying at the edges of the front end 31 of the insole 23. Furthermore, the pressure exerted by the suppliers 22 alone is not sufficient to keep the insole 23 firmly pressed against the sole 15 of the footwear last 2 in the interval of time which elapses between release of the suppliers 22 from the insole 23 and the intervention of the means for folding of the upper 21.

**[0069]** In this case, the suppliers 22 are positioned in the vicinity of the supplier plate 19 (figure 10) and supply the glue 24 onto the insole 23 by moving from the plate 19 towards the rear end 32 of the insole 23 (figures 11 and 12).

**[0070]** Figure 4 and figure 11 show the suppliers 22 in the operative position in the vicinity of the plate 19 and the plate in the intermediate position.

**[0071]** Simultaneously with the movement of positioning of the suppliers 22 in the vicinity of the supplier plate 19, or when the suppliers 22 are in this position, by means of the activation means 40 which are controlled by the command and control means, the supplier plate 19 is moved from - the rest position (R), or, more advantageously, from the intermediate position (I), to the operative position (O), where glue is supplied onto the insole 23 via the nozzles 20.

**[0072]** Subsequently, the suppliers 22 and the plate 19 are returned (figure 12) to the respective rest or intermediate positions. Figure 5 shows the plate 19 and the suppliers 22 in the operative position.

**[0073]** The glue is applied along the contour 27 of the front portion of the insole 23, in particular at the front end 31 of the insole 23.

**[0074]** When the operation of supplying the glue by the plate 19 is completed, the activation means 40 are controlled in order to return the plate 19 to the rest position.

**[0075]** Subsequently, the means 14 for folding the edges of the upper 21 towards the insole 23 are activated, and then the means for pressing the edges themselves against the insole 23 are activated, such as to assure correct gluing of the upper 21 to the insole 23.

**[0076]** At each operating cycle of the machine 1, the

command and control means make it possible to command and control the means for activation 40 and 41 according to the type of insole 23 onto which the upper is to be glued. For example, the operator may decide to use only the suppliers 22, and not to use the supplier plate 19, or to use the said means for supplying the glue 19, 22 in succession, as described in the example previously given.

**[0077]** As can be appreciated from the foregoing description, the machine for production of footwear according to the present invention has structural and functional characteristics which can meet the above-described requirements, at the same time eliminating the disadvantages presented and described with reference to the machines according to the known art for production of footwear.

**[0078]** In particular, the machine can be used in two different operative modes. According to a first operative mode, only movable suppliers are used, in particular for footwear lasts which have a tapered profile and for insoles which have medium to high rigidity. According to a second operative mode, the supplier plate is also used, in particular for footwear lasts which have a profile with an extremely pointed tip, and for insoles with low rigidity.

## Claims

### 1. Machine (1) for production of footwear, comprising:

- positioning means (5) for a footwear last (2), on which an upper (21) is stretched, and to which there is associated a footwear insole (23) which extends between a rear end (32) and a front end (31),
- means (7, 8, 9) for fixing the last (2) on the said positioning means (5),
- a plurality of tensioning grippers (13) in order to engage the edge of the upper (21) and pulling the upper (21) itself, making it adhere to the footwear last (2),
- means for folding (14) and pressing the edge of the upper (21) onto the insole (23), and
- means (19, 22) for supplying the glue (24) onto the insole (23),

wherein the said means (19, 22) for supplying the glue comprise

- a glue supplier plate (19) which has a plurality of nozzles (20) in order to supply the glue along the contour (27) of the front portion of the insole (23), the said plate being movable between a rest position and an operative position in which it is in contact with the insole (23), and
- one or more glue suppliers (22) which are movable to supply the glue along the contour of the insole (23),

### characterised in that

the said rest position of the supplier plate (19) is such as to permit advance of at least one of the said one or more suppliers (22) as far as the front end (31) of the insole (23), without interfering with the supplier plate (19).

2. Machine (1) for production of footwear according to claim 1, wherein the said plate (19) is able to stop in an intermediate position between the rest position and the operative position.

3. Machine (1) for production of footwear according to claim 1 or claim 2, wherein the said plate (19) is movable along a predetermined straight direction (Z-Z) .

4. Machine (1) for production of footwear according to claim 3, wherein the said plate (19) is associated with a telescopic guide (42) which is movable along the said predetermined direction (Z-Z) in order to obtain displacement of the plate (19), between the rest position and the operative position.

5. Machine (1) for production of footwear according to claim 3 or claim 4, wherein, in the rest position, the distance between the plate (19) and the insole (23), measured along the said predetermined direction (Z-Z) is greater than 10 cm.

6. Machine (1) for production of footwear according to claim 5, wherein the said distance is preferably between 10 cm and 12 cm.

7. Machine (1) for production of footwear according to any one of claims 3 to 6, wherein, in the intermediate position, the distance between the plate (19) and the insole (23), measured along the said predetermined direction (Z-Z), is between 1,5 cm and 3 cm.

8. Machine (1) for production of footwear according to claim 7, wherein, in the intermediate position, the distance between the plate (19) and the insole (23), measured along the said predetermined direction (Z-Z), is preferably 2,5 cm.

9. Machine (1) for production of footwear according to any one of claims 1 to 8, wherein the said one or more glue suppliers (22) are able to move along the contour (27) of the insole (23) in order to follow a predetermined path, whilst remaining pressed against the insole (23), such as to keep the insole itself in contact with the sole (15) of the last (2), at least one supplier being able to be released from the insole (23) at a detachment point (32) which is positioned in the vicinity of the front end (31) of the insole (23).

10. Method for application of a glue (24) onto a footwear

insole (23) by means of use of a machine for production of footwear comprising a glue supplier plate (19) for supplying the glue along the contour (27) of the front portion of the insole (23), and one or more movable glue suppliers (22) for supplying the glue along the contour of the insole (23), the said plate being movable between a rest position and an operative position in which it is in contact with the insole (23), in the said rest position the supplier plate (19) permitting the advance of at least one of the said one or more suppliers (22) as far as the front end (31) of the insole (23), without interference with the supplier plate (19), the said method comprising the phases of:

- positioning on a support element (4) a footwear last (2), on which last (2) an upper (21) is stretched and with the sole (15) of which there is associated a footwear insole (23) which extends between a rear end (32) and a front end (31);
- taking the said supplier plate (19) into the said rest position such as to permit advance of the said one or more glue suppliers (22);
- supplying a glue (24) along a portion of the insole by means of the said one or more glue suppliers (22),

wherein, on completion of the said phase of supplying the glue (24), the said at least one supplier is released from the insole (23) at a point of detachment (29) which is positioned in the vicinity of the front end (31) of the insole (23).

#### Patentansprüche

##### 1. Maschine (1) zur Herstellung von Schuhwerk, umfassend:

- Positioniermittel (5) für einen Schuhteil (2), über den ein Obermaterial (21) gespannt wird und dem eine Schuhinnensohle (23) zugeordnet ist, die sich zwischen einem hinteren Ende (32) und einem vorderen Ende (31) erstreckt,
- Mittel (7, 8, 9) zum Fixieren des Leistens (2) an den Positioniermitteln (5),
- eine Mehrzahl von Spanngreifern (13) zum Angreifen am Rand des Obermaterials (21) und zum Ziehen des Obermaterials (21) selbst, um es mit dem Schuhteil (2) zu verkleben,
- Mittel zum Falten (14) und Pressen des Randes des Obermaterials (21) auf die Innensohle (23), und
- Mittel (19, 22) zum Zuführen des Klebstoffs (24) auf die Innensohle (23),

wobei die Mittel (19, 22) zum Zuführen des Klebstoffs umfassen:

- eine Klebstoffzuführplatte (19) mit einer Mehrzahl von Düsen (20) zum Zuführen des Klebstoffs entlang der Kontur (27) des vorderen Bereichs der Innensohle (23), wobei die Platte zwischen einer Ruhestellung und einer Betriebsstellung, in der sie mit der Innensohle (23) in Kontakt steht, bewegbar ist, und
- einen oder mehrere Klebstoffzuführer (22), die bewegbar sind, um den Klebstoff entlang der Kontur der Innensohle (23) zuzuführen,

#### dadurch gekennzeichnet,

**dass** die Ruhestellung der Zuführplatte (19) so ist, dass die Vorwärtsbewegung von mindestens einem Zuführer (22) bis zu dem vorderen Ende (31) der Innensohle (23) erlaubt wird, ohne mit der Zuführplatte (19) zu interferieren.

2. Maschine (1) zur Herstellung von Schuhwerk nach Anspruch 1, wobei die Platte (19) in einer Zwischenstellung zwischen der Ruhestellung und der Betriebsstellung anhalten kann.
3. Maschine (1) zur Herstellung von Schuhwerk nach Anspruch 1 oder Anspruch 2, wobei die Platte (19) entlang einer vorgegebenen geraden Richtung (Z-Z) bewegbar ist.
4. Maschine (1) zur Herstellung von Schuhwerk nach Anspruch 3, wobei der Platte (19) eine Teleskopführung (42) zugeordnet ist, die entlang der vorgegebenen Richtung (Z-Z) bewegbar ist, um eine Verschiebung der Platte (19) zwischen der Ruhestellung und der Betriebsstellung zu erhalten.
5. Maschine (1) zur Herstellung von Schuhwerk nach Anspruch 3 oder Anspruch 4, wobei in der Ruhestellung der Abstand zwischen der Platte (19) und der Innensohle (23), gemessen entlang der vorgegebenen Richtung (Z-Z), größer als 10 cm ist.
6. Maschine (1) zur Herstellung von Schuhwerk nach Anspruch 5, wobei der Abstand vorzugsweise zwischen 10 cm und 12 cm beträgt.
7. Maschine (1) zur Herstellung von Schuhwerk nach einem der Ansprüche 3 bis 6, wobei in der Zwischenstellung der Abstand zwischen der Platte (19) und der Innensohle (23), gemessen entlang der vorgegebenen Richtung (Z-Z), zwischen 1,5 cm und 3 cm beträgt.
8. Maschine (1) zur Herstellung von Schuhwerk nach Anspruch 7, wobei in der Zwischenstellung der Abstand zwischen der Platte (19) und der Innensohle (23), gemessen entlang der vorgegebenen Richtung (Z-Z), vorzugsweise 2,5 cm beträgt.

9. Maschine (1) zur Herstellung von Schuhwerk nach einem der Ansprüche 1 bis 8, wobei der eine oder die mehreren Klebstoffzuführer (22) entlang der Kontur (27) der Innensohle (23) bewegbar sind, um einem vorgegebenen Pfad zu folgen, während sie gegen die Innensohle (23) gedrückt bleiben, so dass die Innensohle selbst mit der Sohle (15) des Leistens (2) in Kontakt bleibt, wobei mindestens ein Zuführer an einem Ablösungspunkt (32), der in der Nachbarschaft des vorderen Endes (31) der Innensohle (23) positioniert ist, von der Innensohle (23) lösbar ist.
10. Verfahren zum Aufbringen eines Klebstoffs (24) auf eine Schuhinnensohle (23) durch die Verwendung einer Maschine zur Herstellung von Schuhwerk, umfassend eine Klebstoffzuführplatte (19) zum Zuführen des Klebstoffs entlang der Kontur (27) des vorderen Bereichs der Innensohle (23) und einen oder mehrere bewegliche Klebstoffzuführer (22) zum Zuführen des Klebstoffs entlang der Kontur der Innensohle (23), wobei die Platte zwischen einer Ruhestellung und einer Betriebsstellung, in der sie mit der Innensohle (23) in Kontakt steht, bewegbar ist, wobei die Zuführplatte (19) in der Ruhestellung die Vorwärtsbewegung von mindestens einem Zuführer (22) bis zu dem vorderen Ende (31) der Innensohle (23) erlaubt, ohne mit der Zuführplatte (19) zu interferieren, wobei das Verfahren die Phasen umfasst:

- Positionieren eines Schuhleistens (2) auf einem Halteelement (4), über welchen Leisten (2) ein Obermaterial (21) gespannt wird und dessen Sohle (15) eine Schuhinnensohle (23) zugeordnet ist, die sich zwischen einem hinteren Ende (32) und einem vorderen Ende (31) erstreckt,
- Bringen der Zuführplatte (19) in die Ruhestellung, so dass eine Vorwärtsbewegung des einen oder der mehreren Klebstoffzuführer (22) erlaubt wird;
- Zuführen eines Klebstoffs (24) entlang einem Bereich der Innensohle mittels des einen oder der mehreren Klebstoffzuführer (22),

wobei nach Beendigung der Phase des Zuführens des Klebstoffs (24) der mindestens eine Zuführer an einem Ablösungspunkt (29), der in der Nachbarschaft des vorderen Endes (31) der Innensohle (23) positioniert ist, von der Innensohle (23) gelöst wird.

## Revendications

1. Machine (1) pour la production d'un article chaussant, comportant :
- des moyens de positionnement (5) pour une forme d'article chaussant (2), sur laquelle une tige (21) est étirée, et à laquelle est associée

une première d'article chaussant (23) qui s'étend entre une extrémité arrière (32) et une extrémité avant (31),

- des moyens (7, 8, 9) pour fixer la forme (2) sur lesdits moyens de positionnement (5),
- une pluralité d'éléments de préhension de tension (13) pour venir en prise avec le bord de la tige (21) et tirer la tige (21) elle-même, en la faisant venir en adhérence sur la forme d'article chaussant (2),
- des moyens pour plier (14) et comprimer le bord de la tige (21) sur la première (23), et
- des moyens (19, 22) pour alimenter de la colle (24) sur la première (23),

lesdits moyens (19, 22) pour alimenter la colle comportant

- une plaque de dispositif d'alimentation en colle (19) qui a une pluralité de buses (20) pour alimenter la colle le long du contour (27) de la partie avant de la première (23), ladite plaque étant mobile entre une position de repos et une position opérationnelle dans laquelle elle est en contact avec la première (23), et
- un ou plusieurs dispositif(s) d'alimentation en colle (22) qui est (sont) mobile(s) pour alimenter la colle le long du contour de la première (23),

## caractérisée en ce que

ladite position de repos de ladite plaque de dispositif d'alimentation (19) est telle qu'elle permet l'avance d'au moins un parmi les un ou plusieurs dispositifs d'alimentation (22) aussi loin que l'extrémité avant (31) de la première (23), sans interférer avec la plaque de dispositif d'alimentation (19).

2. Machine (1) pour la production d'un article chaussant selon la revendication 1, dans laquelle ladite plaque (19) est capable de s'arrêter dans une position intermédiaire entre la position de repos et la position opérationnelle.
3. Machine (1) pour la production d'un article chaussant selon la revendication 1 ou la revendication 2, dans laquelle ladite plaque (19) est mobile le long d'une direction rectiligne prédéterminée (Z-Z).
4. Machine (1) pour la production d'un article chaussant selon la revendication 3, dans laquelle ladite plaque (19) est associée à un guide télescopique (42) qui est mobile le long de ladite direction prédéterminée (Z-Z) pour obtenir un déplacement de la plaque (19), entre la position de repos et la position opérationnelle.
5. Machine (1) pour la production d'un article chaussant selon la revendication 3 ou la revendication 4, dans

- laquelle, dans la position de repos, la distance entre la plaque (19) et la première (23), mesurée le long de ladite direction prédéterminée (Z-Z), est supérieure à 10 cm.
6. Machine (1) pour la production d'un article chaussant selon la revendication 5, dans laquelle ladite distance est de préférence comprise entre 10 cm et 12 cm.
7. Machine (1) pour la production d'un article chaussant selon l'une quelconque des revendications 3 à 6, dans laquelle, dans la position intermédiaire, la distance entre la plaque (19) et la première (23), mesurée le long de ladite direction prédéterminée (Z-Z), est comprise entre 1,5 cm et 3 cm.
8. Machine (1) pour la production d'un article chaussant selon la revendication 7, dans laquelle, dans la position intermédiaire, la distance entre la plaque (19) et la première (23), mesurée le long de ladite direction prédéterminée (Z-Z), est de préférence de 2,5 cm.
9. Machine (1) pour la production d'un article chaussant selon l'une quelconque des revendications 1 à 8, dans laquelle ledit un ou lesdits plusieurs dispositif(s) d'alimentation en colle (22) est (sont) capable(s) de se déplacer le long du contour (27) de la première (23) pour suivre un trajet prédéterminé, tout en restant comprimé(s) contre la première (23), de manière à maintenir la première elle-même en contact avec la semelle (15) de la forme (2), au moins un dispositif d'alimentation étant capable d'être libéré de la première (23) au niveau d'un point de séparation (32) qui est positionné à proximité de l'extrémité avant (31) de la première (23).
10. Procédé d'application d'une colle (24) sur une première (23) d'article chaussant par l'intermédiaire de l'utilisation d'une machine pour la production d'un article chaussant comportant des dispositifs d'alimentation en colle (19) pour alimenter la colle le long du contour (27) de la partie avant de la première (23), et un ou plusieurs dispositif(s) d'alimentation en colle (22) mobile(s) pour alimenter la colle le long du contour de la première (23), ladite plaque étant mobile entre une position de repos et une position opérationnelle dans laquelle elle est en contact avec la première (23), dans ladite position de repos, la plaque de dispositif d'alimentation (19) permettant l'avance d'au moins un dudit ou desdits dispositif(s) d'alimentation (22) aussi loin que l'extrémité avant (31) de la première (23), sans interférence avec la plaque de dispositif d'alimentation (19), ledit procédé comportant les étapes consistant à :

quelle une tige (21) est étirée, et dont la semelle (15) est associée à une première d'article chaussant (23) qui s'étend entre une extrémité arrière (32) et une extrémité avant (31),

- mettre ladite plaque de dispositif d'alimentation (19) dans ladite position de repos, de manière à permettre l'avance dudit ou desdits dispositif(s) d'alimentation en colle (22),
- alimenter une colle (24) le long d'une partie de la première par l'intermédiaire dudit ou desdits dispositif(s) d'alimentation en colle (22),

dans lequel, à l'achèvement de ladite phase consistant à alimenter la colle (24), ledit au moins un dispositif d'alimentation est libéré de la première (23) au niveau d'un point de séparation (29) qui est positionné à proximité de l'extrémité avant (31) de la première (23).

- positionner sur un élément de support (4) une forme d'article chaussant (2), forme (2) sur la-

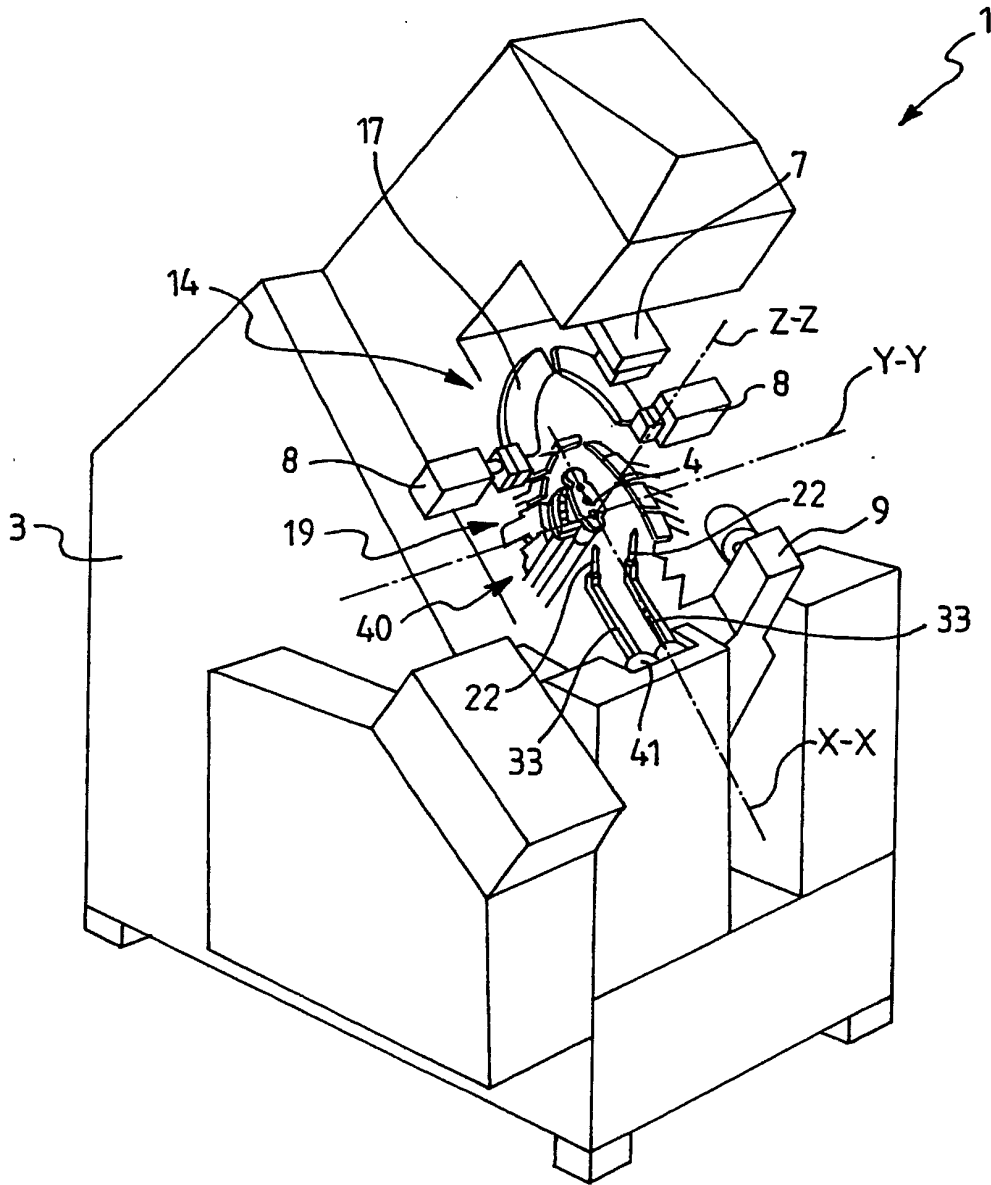

FIG. 1

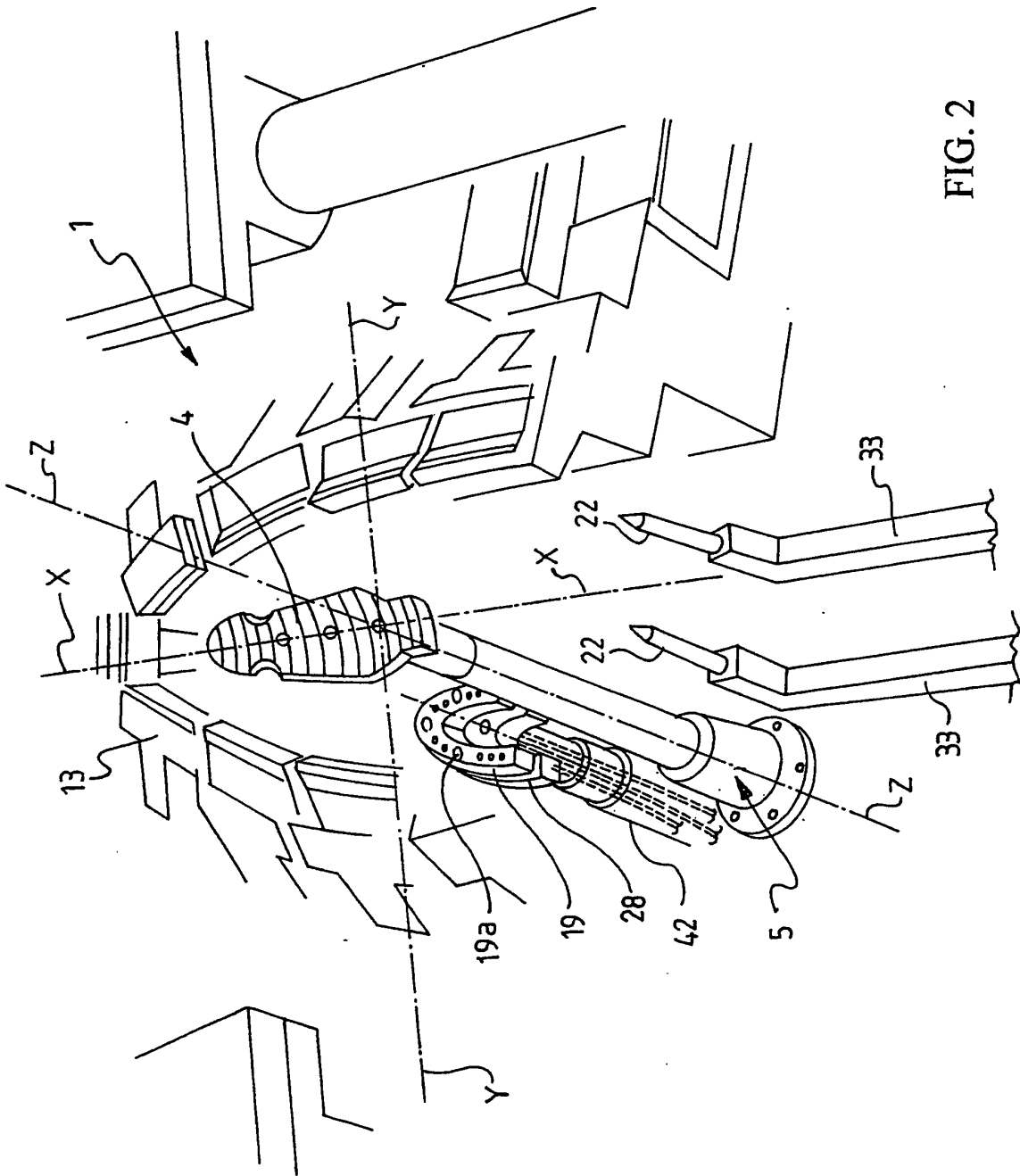

FIG. 2

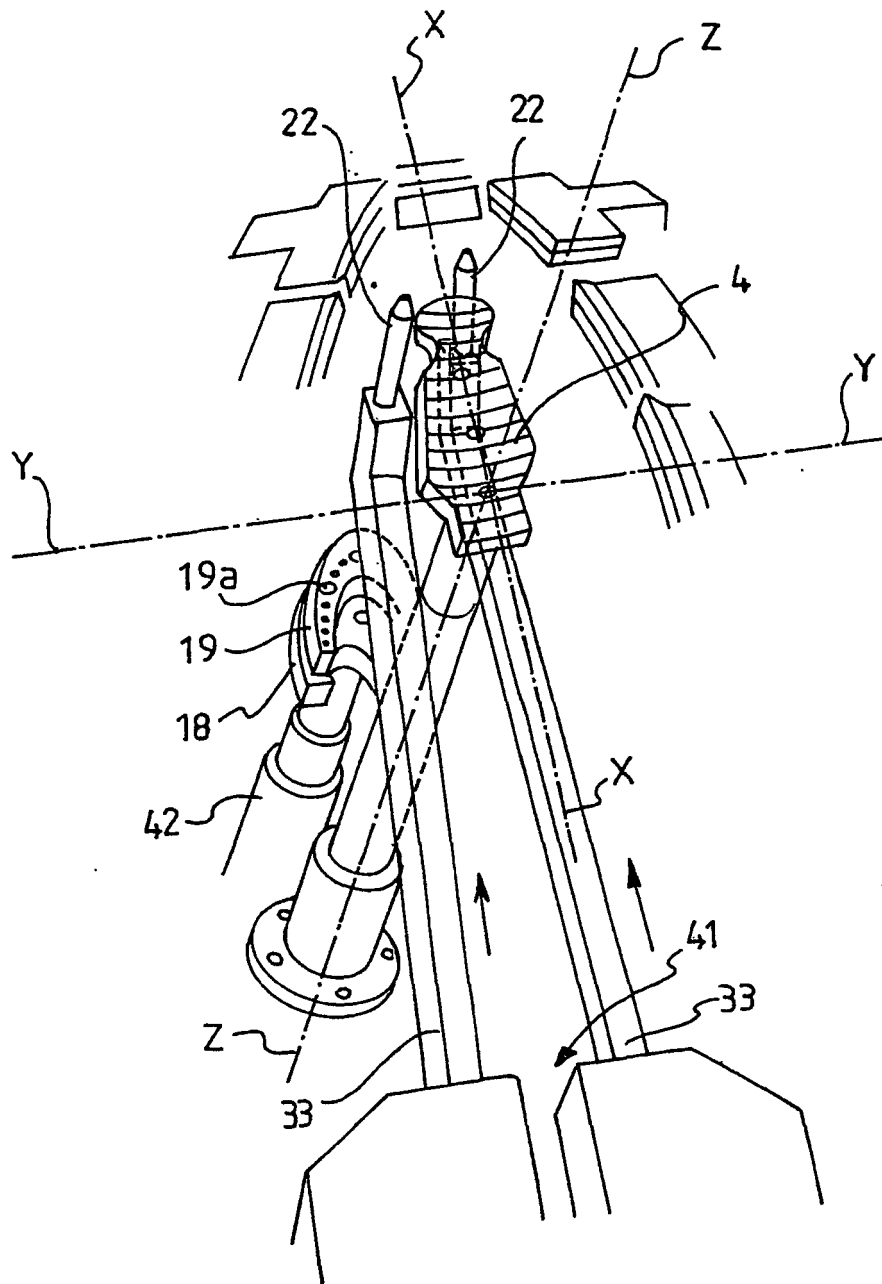

FIG. 3

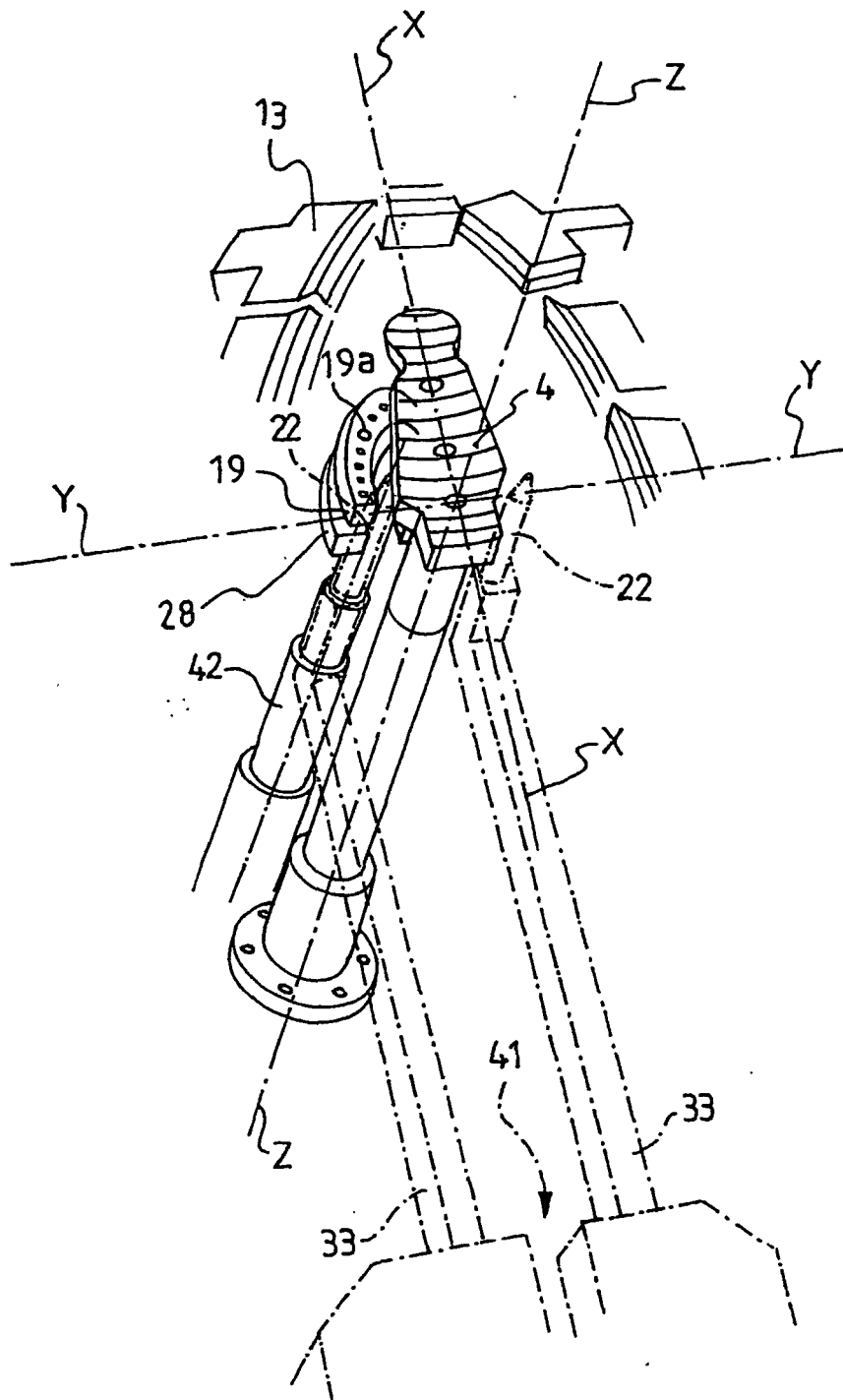

FIG. 4

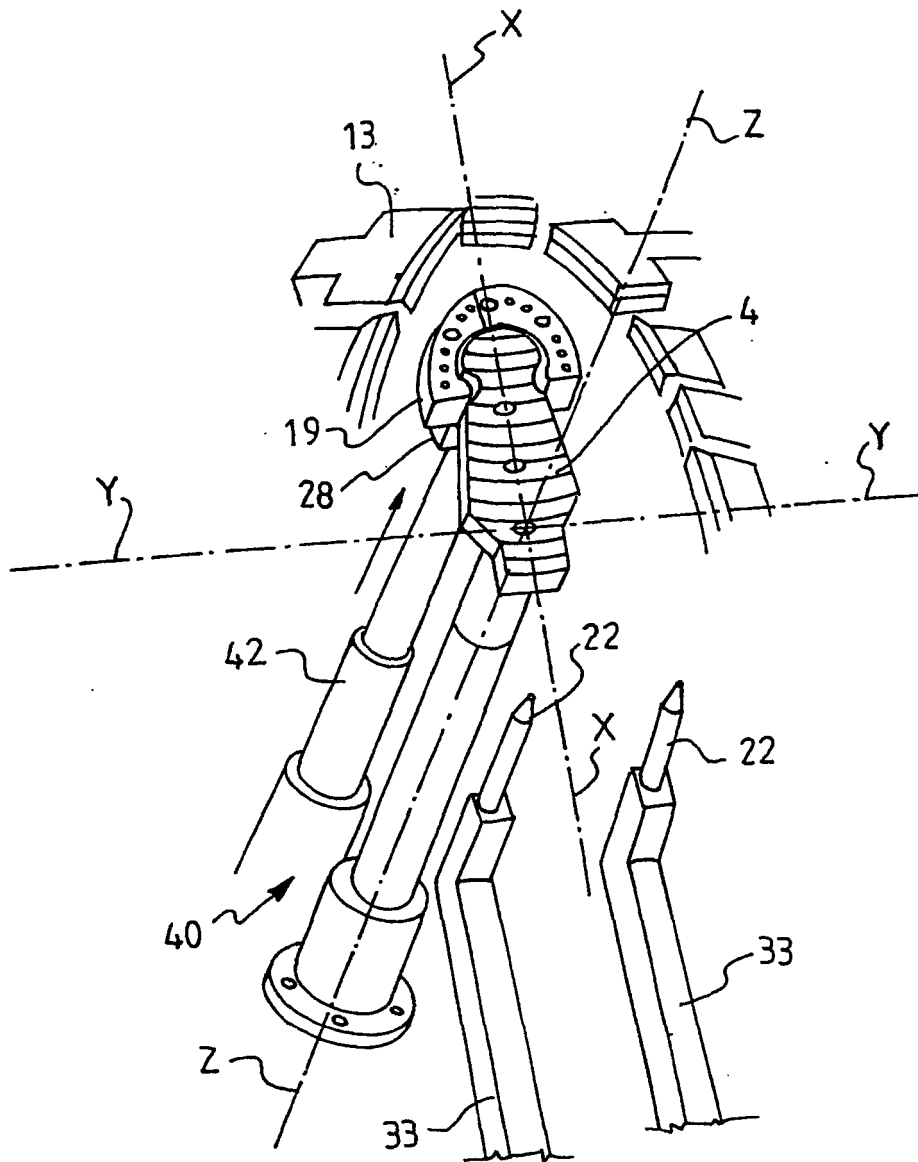

FIG. 5

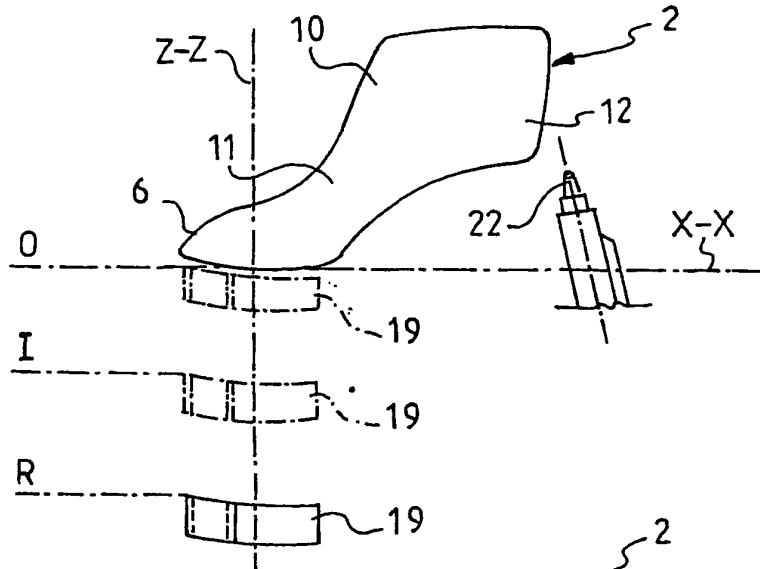

FIG. 6

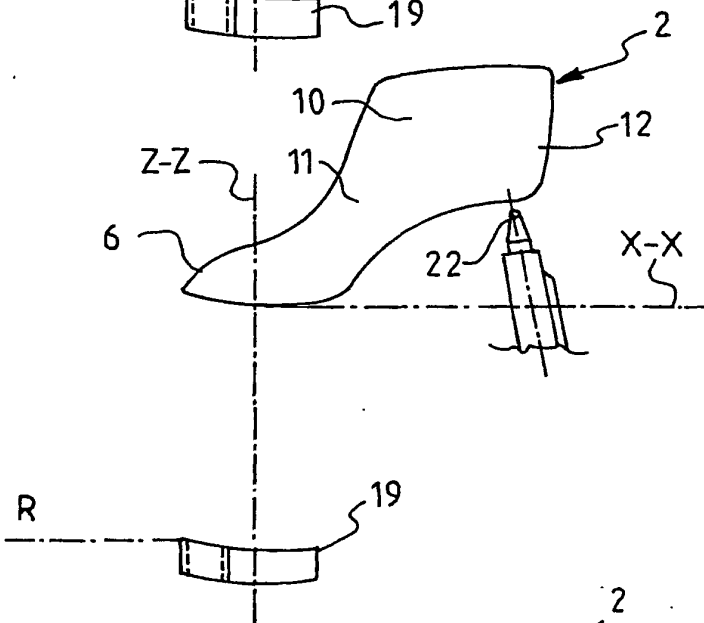

FIG. 7

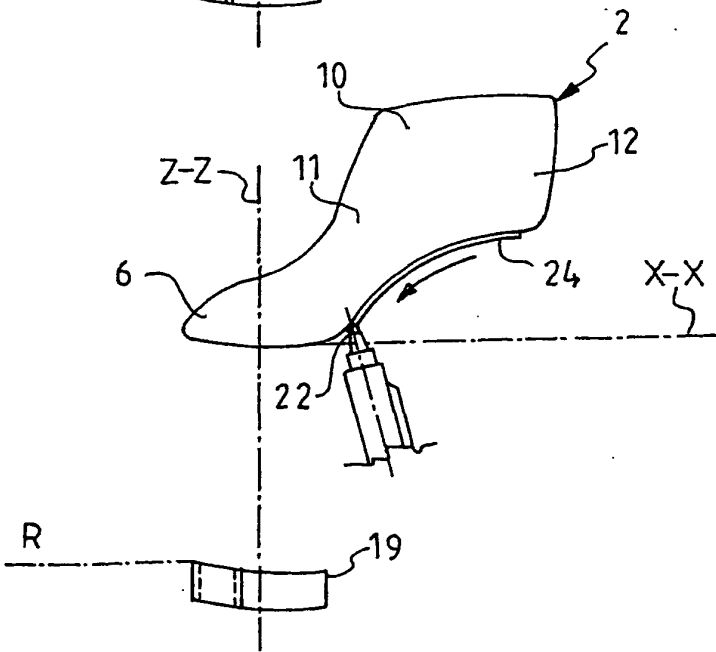

FIG. 8

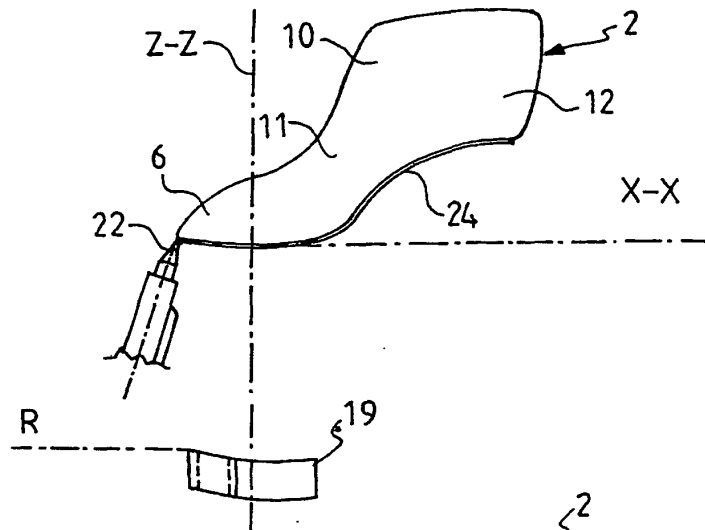

FIG. 9

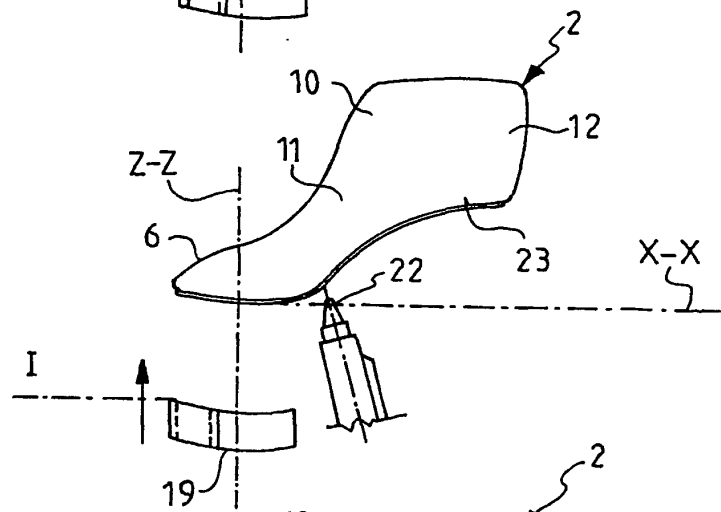

FIG. 10

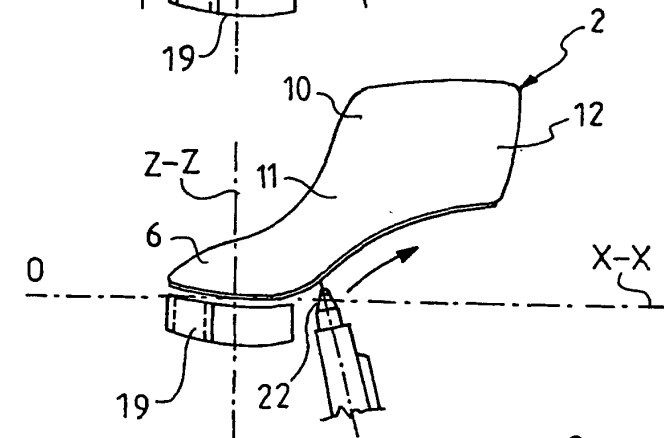

FIG. 11

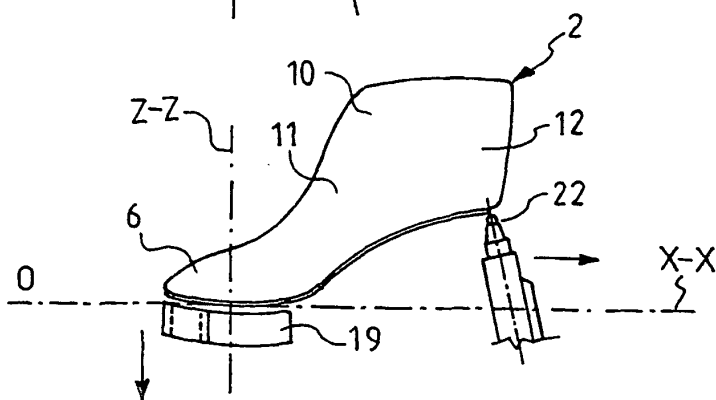

FIG. 12

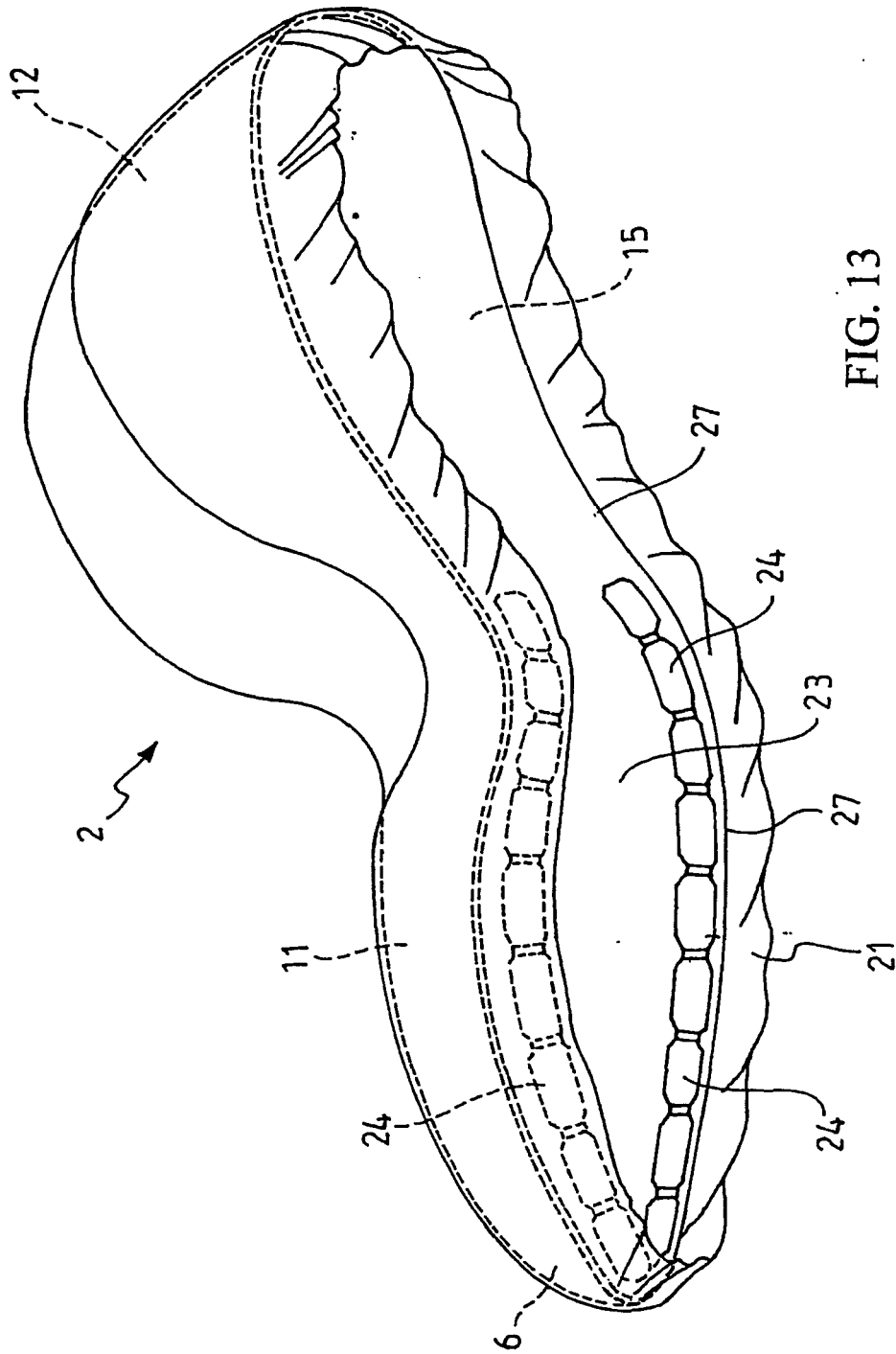

FIG. 13

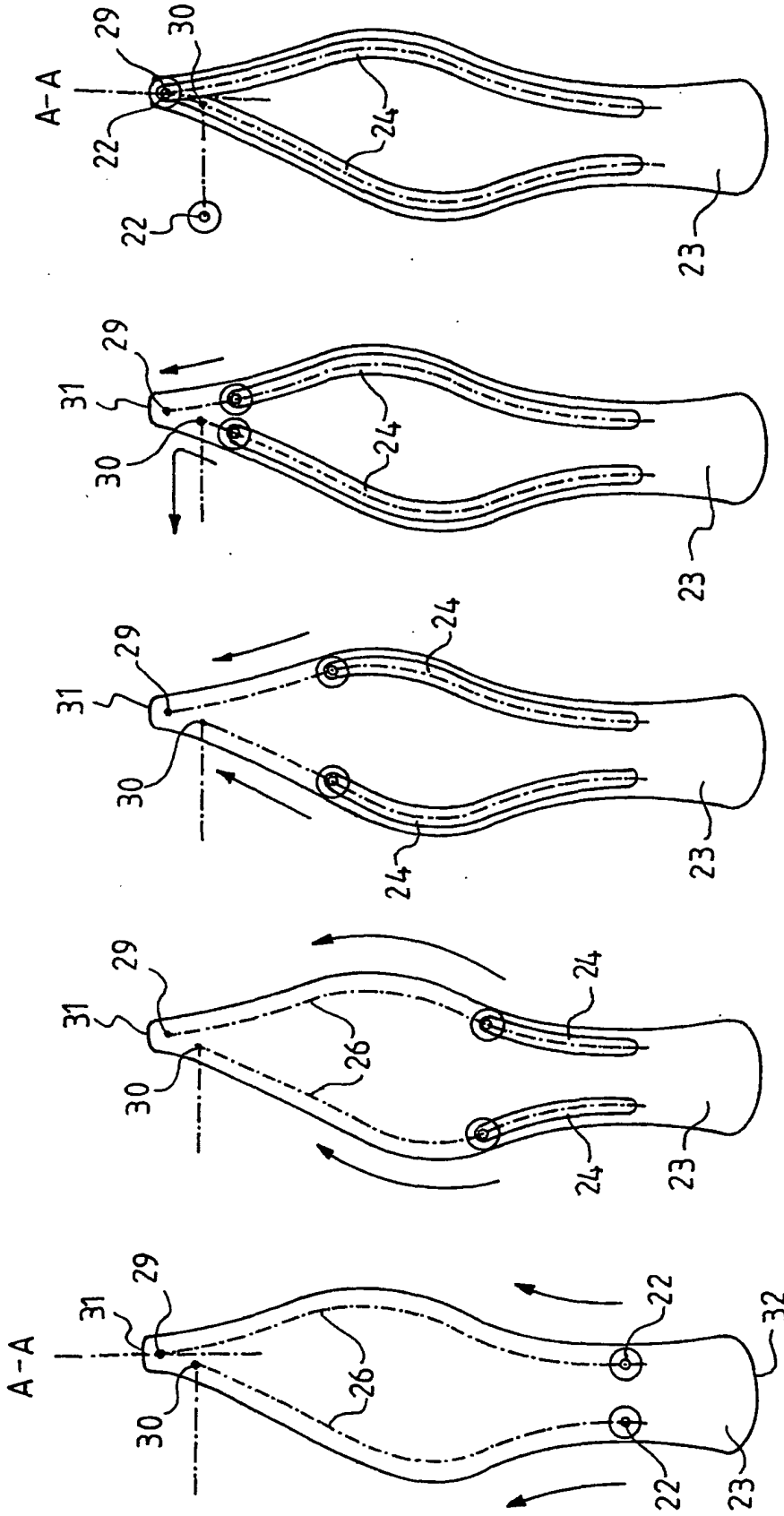

FIG. 14

FIG. 15

FIG. 16

FIG. 17

FIG. 18