



INTERNATIONAL APPLICATION PUBLISHED UNDER THE PATENT COOPERATION TREATY (PCT)

<p>(51) International Patent Classification ⁶ : G02F 1/1335</p>	<p>A1</p>	<p>(11) International Publication Number: WO 96/18129 (43) International Publication Date: 13 June 1996 (13.06.96)</p>
<p>(21) International Application Number: PCT/GB95/02628 (22) International Filing Date: 9 November 1995 (09.11.95) (30) Priority Data: 9424924.0 9 December 1994 (09.12.94) GB (71) Applicant (for all designated States except US): CENTRAL RESEARCH LABORATORIES LIMITED [GB/GB]; Dawley Road, Hayes, Middlesex UB3 1HH (GB). (72) Inventors; and (75) Inventors/Applicants (for US only): HOLDEN, John [GB/GB]; Central Research Laboratories, Dawley Road, Hayes, Middlesex UB3 1HH (GB). DOBRUSSKIN, Christoph [NL/NL]; Philips Corporate Design, Building SX, Postbox 218, NL-5600 MD Eindhoven (NL). (74) Agent: MARSH, Robin, Geoffrey; Thom Emi Patents Limited, Central Research Laboratories, Dawley Road, Hayes, Middlesex UB3 1HH (GB).</p>		<p>(81) Designated States: CA, JP, US, European patent (AT, BE, CH, DE, DK, ES, FR, GB, GR, IE, IT, LU, MC, NL, PT, SE). Published With international search report.</p>

(54) Title: A DEVICE FOR BACKLIGHTING A LIQUID CRYSTAL PANEL

(57) Abstract

A device for backlighting a liquid crystal panel (4) comprises a source (1) of diffuse light, a quarter wave retarder (3), and a circularly polarizing element (2) arranged between the source and the retarder. In operation, diffuse light from the source passes through the circularly polarizing element and then through the retarder, thereby providing un-collimated plane-polarized light for backlighting a liquid crystal display. The device can give the advantage of enabling the use of cheaper, lower quality optical elements and eliminating expensive collimators.

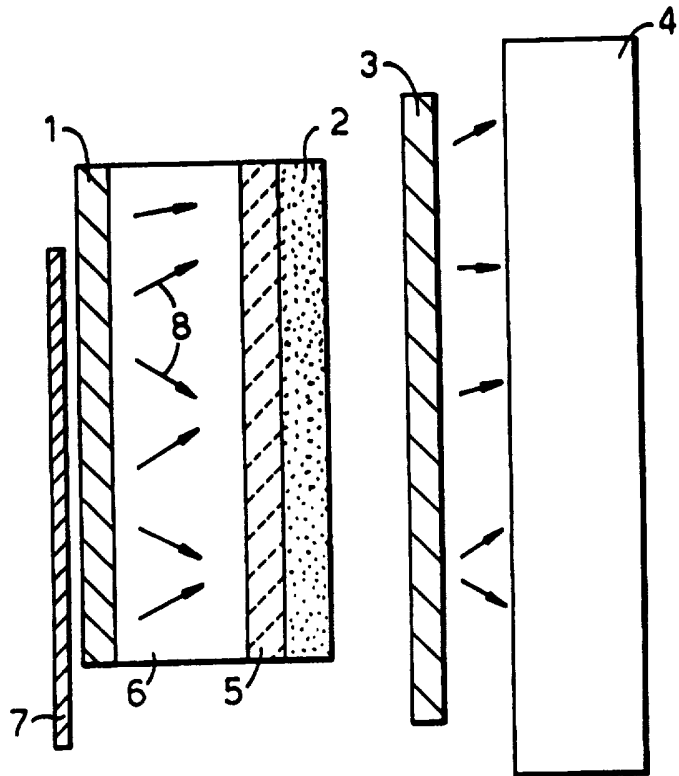

FOR THE PURPOSES OF INFORMATION ONLY

Codes used to identify States party to the PCT on the front pages of pamphlets publishing international applications under the PCT.

AT	Austria	GB	United Kingdom	MR	Mauritania
AU	Australia	GE	Georgia	MW	Malawi
BB	Barbados	GN	Guinea	NE	Niger
BE	Belgium	GR	Greece	NL	Netherlands
BF	Burkina Faso	HU	Hungary	NO	Norway
BG	Bulgaria	IE	Ireland	NZ	New Zealand
BJ	Benin	IT	Italy	PL	Poland
BR	Brazil	JP	Japan	PT	Portugal
BY	Belarus	KE	Kenya	RO	Romania
CA	Canada	KG	Kyrgystan	RU	Russian Federation
CF	Central African Republic	KP	Democratic People's Republic of Korea	SD	Sudan
CG	Congo	KR	Republic of Korea	SE	Sweden
CH	Switzerland	KZ	Kazakhstan	SI	Slovenia
CI	Côte d'Ivoire	LI	Liechtenstein	SK	Slovakia
CM	Cameroon	LK	Sri Lanka	SN	Senegal
CN	China	LU	Luxembourg	TD	Chad
CS	Czechoslovakia	LV	Latvia	TG	Togo
CZ	Czech Republic	MC	Monaco	TJ	Tajikistan
DE	Germany	MD	Republic of Moldova	TT	Trinidad and Tobago
DK	Denmark	MG	Madagascar	UA	Ukraine
ES	Spain	ML	Mali	US	United States of America
FI	Finland	MN	Mongolia	UZ	Uzbekistan
FR	France			VN	Viet Nam
GA	Gabon				

A DEVICE FOR BACKLIGHTING A LIQUID CRYSTAL PANEL

This invention relates to a device for backlighting a liquid crystal panel, comprising a source of light, a quarter wave retarder and a circularly polarizing element being arranged between the source and the retarder, such that in operation
5 light from the source passes through the circularly polarizing element and through the quarter wave retarder, thereby providing plane-polarized light for backlighting a liquid crystal panel.

A known such device is disclosed in WO 94/16355. In this device the
10 circularly polarizing element comprises a plurality of aligned cholesteric liquid crystal layers each reflecting light of a first circular polarization and transmitting light of the other sense of circular polarization. The device also includes Fresnel lenses to collimate and condense the light to provide a bright source suitably for use in an overhead projection system.

The use of such a device in an overhead projection system requires the use of
15 large area optical quality retarder and polarizer elements. A further requirement is Fresnel lenses or other collimating means. Such additional elements are expensive to manufacture and require alignment of the optical system to work in an optimum fashion. Both of these aspects increase the cost of making the device. In addition such
20 prior art devices only operate over a restricted angle of view.

It is an object of the present invention to enable the above disadvantages to be mitigated.

According to the invention there is provided a device for backlighting a liquid
25 crystal panel as defined in the first paragraph above, characterized in that the light being supplied to the quarter wave retarder from the source is diffuse and/or uncollimated.

Such a device can be cheaper and easier to manufacture for use with non-
30 projection liquid crystal displays. Preferably the light source emits substantially unpolarized light, which increases the potential efficiency of the system and further minimizes cost.

The circularly polarizing element may conveniently comprise an aligned chiral
liquid crystal material, which reduces the absorption of light having the opposite sense of circular polarization. The circularly polarizing element may advantageously
35 comprises a plurality of laminae, each lamina having a respective wavelength reflective characteristic. Preferably, the circularly polarizing element comprises a plurality of flakes of an aligned chiral liquid crystal material which is a solid at room temperature, the flakes being carried on a light transmissive substrate

The light source may consist of a luminescent element having an area approximately equal to that of the liquid crystal panel to be illuminated. This can optimize the efficiency of the device in the absence of a collimating optical system. Preferably the luminescent element comprises a planar layer of luminescent material.

5 Embodiments of the invention will now be described, by way of example only, with reference to the accompanying diagrammatic drawings, in which Figure 1 shows, a cross section of a first device, and Figure 2 shows, a cross section of a second device.

10 In Figure 1, a device for backlighting a liquid crystal panel (4), comprises a source of light consisting in the present example of a layer of a phosphor material (1) on the exterior of a surface of a glass envelope of an electrodeless lamp having a gas filled central cavity (6) and a dichroic UV mirror (5) which allows all non-UV light to pass through provided on the opposite surface of the glass envelope, a quarter wave retarder (3), and a circularly polarizing element (2) arranged between the light source (1) and the retarder (3). The electrodeless lamp has an external spiral electrode (7). In operation, diffuse unpolarized light (8) is emitted by the phosphor layer (1). This light passes through the circularly polarizing element (2) in its way towards the retarder (3) and ultimately the liquid crystal panel (4).

15 The circularly polarizing element (2) comprises a layer of a chiral liquid crystal material (in the present example a layer of an aligned cholesteric liquid crystal polymer which has been UV cross-linked and is a solid at room temperature). In operation, the phosphor layer is excited by UV light generated in the gas filled cavity by a plasma driven by the spiral external electrode. The phosphor layer may in general be on an internal or external surface of this envelope, or on another surface within the envelope.

20 Obviously in the present case where the phosphor is on an external surface envelope must be made from quartz or another material which is transparent to such UV light, otherwise the layers (1) and (5) would need to be on the internal surfaces of the envelope. This excitation produces visible light which is diffuse and unpolarized. This light will emerge from the lamp and pass through the UV dichroic filter to impinge upon the circularly polarizing element. The UV dichroic filter is there to improve the lamp efficiency by directing UV light which is generated by the plasma in the gas filled cavity back towards the phosphor layer so that it is not lost.

25 The circularly polarizing element in the present example is chosen to have a reflection characteristic such that all visible wavelengths being left-hand circularly polarized are reflected back towards the light source. This reflected light will then be re-reflected by the phosphor layer. This second reflection (and any subsequent odd numbered reflections from the phosphor layer) will change the polarization state of the

30

35

light to be right hand circularly polarized, such that when the light again emerges from the lamp and impinges upon the circularly polarizing element it will be transmitted. Thus the light travelling towards the quarter wave retarder will be diffuse uncollimated light having no left hand circular polarized component, but having a larger than usual
5 right hand circularly polarized component. This predominantly right hand circularly polarized light will be transformed into predominantly linearly polarized light by the quarter wave retarder (3), so that the liquid crystal display panel (4) is illuminated by this light.

10 In the present example, the light source (1) has an area which is slightly smaller than that of the liquid crystal panel, but is of approximately the same size.

Figure 2 shows a cross section of a second device according to the invention. Elements of the device having the same function in Figure 1 and Figure 2 are denoted by the same numerals where possible. In this second example the light source comprises a bank of elongate fluorescent tubes (10) which emit white light towards a
15 diffusive light-transmissive sheet (11). This sheet is coated on the side facing away from the fluorescent tubes with a layer comprising flakes of a solid aligned cholesteric liquid crystal polymer in a light transmissive non birefringent binder. This sheet forms a liquid crystal lamina which acts as a diffusing circularly polarizing element. The rest of the device in this second example comprises a quarter wave retarder (3) and liquid
20 crystal panel (4), as in the first example described above. In this example, the source of diffusive light may be replaced by a point light source as the circularly polarizing element will cause the light impinging upon the quarter wave retarder to be diffuse. As an alternative to a diffusive light source, a point light source plus diffusing means may in general be substituted.

25 As a further example, the light source may take the form of an edge-lit transparent sheet having a diffusive coating such as white paint on its rear surface. The light source may also be constituted by an illuminated sheet of fluorescent plastic.

Although in the above examples the chiral liquid crystal lamina has only a single reflection characteristic which substantially spans the visible wave band, the layer may
30 be made up from a plurality of layers (or a plurality of flakes in a single layer) each having a respective wavelength reflection band. If such bands are arranged such that substantially the whole visible wave band is in one or other of the respective reflection characteristics an equivalent high efficiency device also results. In order to ensure that the light from the device is substantially polarized for large angles of view, it is
35 desirable that the reflection characteristics extend into the ultra-violet region of the spectrum.

The devices described above may be provided with a liquid crystal panel to give a display device, or can be provided for use with a separate liquid crystal panel. The devices described can have significant advantages over those described in the prior art. In particular the devices are simpler and cheaper to construct and do not require alignment of focussing or collimating means. In addition, the devices are suitable for display devices which are not to be used for overhead projector applications. The devices have the potential for a much wider angle of view or much wider angle of polarized illumination. The use of a circular polarizing element which is not of a high optical quality (e.g. consisting of a plurality of separate flakes supported on a light transmissive substrate) may significantly reduce the cost of manufacture.

CLAIMS

1. A device for backlighting a liquid crystal panel, comprising a source of light (1), a quarter wave retarder (3), and a circularly polarizing element (2) being arranged between the source and the retarder, such that in operation light from the source passes through the circularly polarizing element and through the quarter wave retarder, thereby providing plane-polarized light for backlighting a liquid crystal panel, characterized in that the light being supplied to the quarter wave retarder from the source is diffuse and/or un-collimated.
2. A device as claimed in claim 1 in which the source emits substantially unpolarized light in operation.
3. A device as claimed in any preceding claim in which the circularly polarizing element comprises an aligned chiral liquid crystal material.
4. A device as claimed in any preceding claim in which the circularly polarizing element comprises a plurality of chiral liquid crystal laminae, each lamina having a respective reflection characteristic.
5. A device as claimed in claim 4 in which the circularly polarizing element comprises a plurality of flakes of an aligned chiral liquid crystal material which is a solid at room temperature, the flakes being carried by a light transmissive member.
6. A device as claimed in any preceding claim in which the source of light is constituted by a luminescent element.
7. A device as claimed in claim 6 in which the luminescent element comprises a planar layer of luminescent material.
8. A device as claimed in claim 1 further comprising a liquid crystal panel backlit by the source of light in operation.
9. A device as claimed in claim 8, in which the source of light is constituted by a luminescent element being of approximately equal area to the liquid crystal panel.

Fig.1.

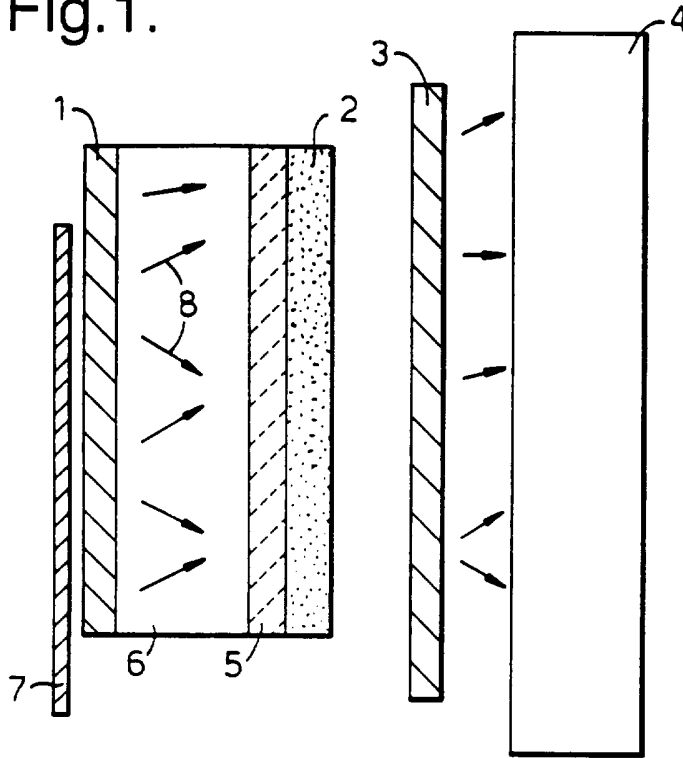
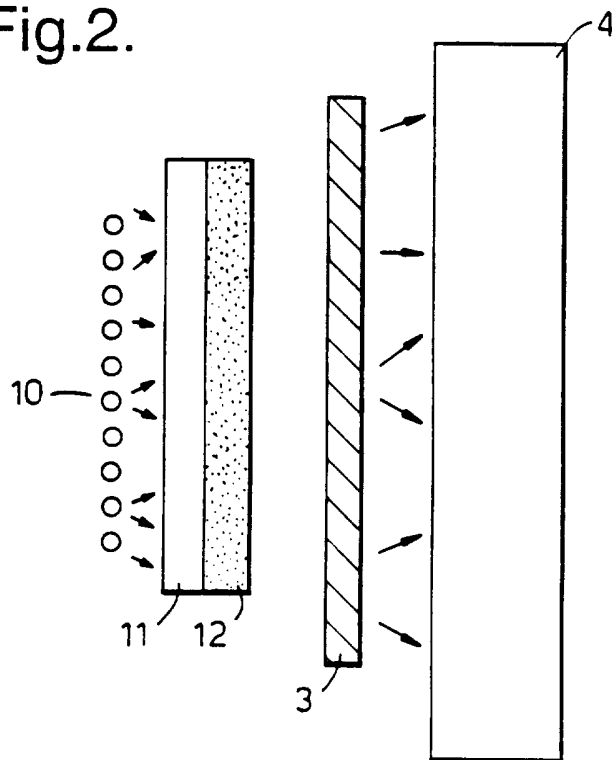

Fig.2.



INTERNATIONAL SEARCH REPORT

International Application No
PCT/GB 95/02628

A. CLASSIFICATION OF SUBJECT MATTER IPC 6 G02F1/1335				
According to International Patent Classification (IPC) or to both national classification and IPC				
B. FIELDS SEARCHED				
Minimum documentation searched (classification system followed by classification symbols) IPC 6 G02F				
Documentation searched other than minimum documentation to the extent that such documents are included in the fields searched				
Electronic data base consulted during the international search (name of data base and, where practical, search terms used)				
C. DOCUMENTS CONSIDERED TO BE RELEVANT				
Category *	Citation of document, with indication, where appropriate, of the relevant passages	Relevant to claim No.		
X Y Y	EP,A,0 606 939 (PHILIPS N.V) 20 July 1994 see column 9, line 05 - column 14, line 25 --- EP,A,0 275 601 (PHILIPS N.V) 27 July 1988 see page 4, line 38 - page 7, line 06 -----	1-5 6-9 6-9		
<input type="checkbox"/> Further documents are listed in the continuation of box C.				
<input checked="" type="checkbox"/> Patent family members are listed in annex.				
* Special categories of cited documents :				
<table style="width: 100%; border: none;"> <tr> <td style="width: 50%; vertical-align: top; padding: 5px;"> *A* document defining the general state of the art which is not considered to be of particular relevance *E* earlier document but published on or after the international filing date *L* document which may throw doubts on priority claim(s) or which is cited to establish the publication date of another citation or other special reason (as specified) *O* document referring to an oral disclosure, use, exhibition or other means *P* document published prior to the international filing date but later than the priority date claimed </td> <td style="width: 50%; vertical-align: top; padding: 5px;"> *T* later document published after the international filing date or priority date and not in conflict with the application but cited to understand the principle or theory underlying the invention *X* document of particular relevance; the claimed invention cannot be considered novel or cannot be considered to involve an inventive step when the document is taken alone *Y* document of particular relevance; the claimed invention cannot be considered to involve an inventive step when the document is combined with one or more other such documents, such combination being obvious to a person skilled in the art. *&* document member of the same patent family </td> </tr> </table>			*A* document defining the general state of the art which is not considered to be of particular relevance *E* earlier document but published on or after the international filing date *L* document which may throw doubts on priority claim(s) or which is cited to establish the publication date of another citation or other special reason (as specified) *O* document referring to an oral disclosure, use, exhibition or other means *P* document published prior to the international filing date but later than the priority date claimed	*T* later document published after the international filing date or priority date and not in conflict with the application but cited to understand the principle or theory underlying the invention *X* document of particular relevance; the claimed invention cannot be considered novel or cannot be considered to involve an inventive step when the document is taken alone *Y* document of particular relevance; the claimed invention cannot be considered to involve an inventive step when the document is combined with one or more other such documents, such combination being obvious to a person skilled in the art. *&* document member of the same patent family
A document defining the general state of the art which is not considered to be of particular relevance *E* earlier document but published on or after the international filing date *L* document which may throw doubts on priority claim(s) or which is cited to establish the publication date of another citation or other special reason (as specified) *O* document referring to an oral disclosure, use, exhibition or other means *P* document published prior to the international filing date but later than the priority date claimed	*T* later document published after the international filing date or priority date and not in conflict with the application but cited to understand the principle or theory underlying the invention *X* document of particular relevance; the claimed invention cannot be considered novel or cannot be considered to involve an inventive step when the document is taken alone *Y* document of particular relevance; the claimed invention cannot be considered to involve an inventive step when the document is combined with one or more other such documents, such combination being obvious to a person skilled in the art. *&* document member of the same patent family			
Date of the actual completion of the international search <p style="text-align: center; font-size: 1.2em;">14 March 1996</p>	Date of mailing of the international search report <p style="text-align: center; font-size: 1.2em;">22.03.96</p>			
Name and mailing address of the ISA European Patent Office, P.B. 5818 Patentlaan 2 NL - 2280 HV Rijswijk Tel. (+ 31-70) 340-2040, Tx. 31 651 epo nl, Fax (+ 31-70) 340-3016	Authorized officer <p style="text-align: center; font-size: 1.2em;">Diot, P</p>			

INTERNATIONAL SEARCH REPORT

...information on patent family members

Inter nal Application No
PCT/GB 95/02628

Patent document cited in search report	Publication date	Patent family member(s)	Publication date
EP-A-606939	20-07-94	CN-A- 1092528 JP-A- 6324333	21-09-94 25-11-94

EP-A-275601	27-07-88	AU-B- 8293687 CA-A- 1274613 DE-D- 3788274 DE-T- 3788274 JP-A- 1173091 US-A- 4882617	30-06-88 25-09-90 05-01-94 19-05-94 07-07-89 21-11-89
