



Europäisches Patentamt
European Patent Office
Office européen des brevets



(11) **EP 0 789 105 B1**

(12) **EUROPEAN PATENT SPECIFICATION**

(45) Date of publication and mention
of the grant of the patent:
28.11.2001 Bulletin 2001/48

(51) Int Cl.7: **D06F 58/24, D06F 58/22**

(21) Application number: **96202695.1**

(22) Date of filing: **26.09.1996**

(54) **Laundry-drier with a panel-type front door and extractable tank for collecting condensation water**

Wäschetrockner mit einer Frontplattentypetür und einem abnehmbaren Kondensatsammelbehälter

Sèche linge avec porte de type à panneau frontal et avec réservoir extractible pour collecter l'eau condensée

(84) Designated Contracting States:
FR IT

(72) Inventor: **Fumagalli, Silvano**
20052 Monza, Milano (IT)

(30) Priority: **06.02.1996 IT MI960095 U**

(74) Representative: **Perani, Aurelio et al**
c/o JACOBACCI & PERANI S.p.A
Via Senato 8
20121 Milano (IT)

(43) Date of publication of application:
13.08.1997 Bulletin 1997/33

(73) Proprietor: **CANDY S.p.A.**
I-20052 Monza (Milano) (IT)

(56) References cited:
EP-A- 0 555 703 **GB-A- 2 115 127**

EP 0 789 105 B1

Note: Within nine months from the publication of the mention of the grant of the European patent, any person may give notice to the European Patent Office of opposition to the European patent granted. Notice of opposition shall be filed in a written reasoned statement. It shall not be deemed to have been filed until the opposition fee has been paid. (Art. 99(1) European Patent Convention).

Description

[0001] The present invention relates to the laundry-drying machines of the domestic type, with a panel-type front door and extractable tank for collecting the condensation water.

[0002] Front-loading laundry-drying machines are known, both of the type in which the loading opening is closed by a porthole and of the type in which the loading opening is closed by a continuous panel which covers the entire front surface of the machine excluding the single control panel and a lower base.

[0003] For reasons of space and rational utilization of the limited volume available, there is a trend towards providing said laundry-drying machines with a tank for collecting the condensation water, which is removably accommodated in the space formed by the loading opening and supported by the closing door.

[0004] If this solution is adopted, it is necessary to solve various technical problems:

[0005] It is necessary to ensure that the drying circuit is sealed relative to the external atmosphere to avoid humid air escaping.

[0006] It is necessary to provide in the drying circuit, at the exit of the drying chamber, an easily removable and cleanable filter for catching the fluff and down released by the fabrics, to avoid these being carried along and accumulated in a condenser.

[0007] It is necessary to ensure that the tank for collecting the condensation water does not become pressurized by the gradual filling and that, in the event that the tank is completely filled, the operation of the machine is stopped to avoid the accumulation of water in the condenser which is provided with a reservoir of limited capacity for collecting the condensate.

[0008] Various solutions have been proposed for solving these problems, none of which fully satisfies the requirements, resulting in constructional complications which reduce the reliability of the machines and involve great difficulty of operation.

[0009] EP-A-0 555 703 discloses an arrangement according to the preamble of claim 1.

[0010] According to the present invention, these problems are effectively solved in a constructionally simple and reliable manner which ensures extreme ease of operation, by a laundry-drying machine with a panel-type front door and an extractable tank for collecting condensate, which can be removed when the door is open.

[0011] The tank is provided, on its upper face, with a filling opening which freely faces, when the door is closed, a pipe for supplying condensation water, without the use of sealing connections or overflow pressure switches.

[0012] Any overflow of the tank is collected in the cassette housing of the tank and from this is conveyed by means of appropriate lower discharge means into a condenser reservoir of the machine.

[0013] The cassette housing of the tank also consti-

tutes a section of the drying circuit leaving the rotating basket for containing the laundry, which is closed by a perforated protection diaphragm and in which, interposed between diaphragm and collecting tank, there is accommodated a filter for catching fluff, which can be removed separately from said tank and cleaned easily.

[0014] A first seal arranged all around the loading opening ensures, when the door is closed, the sealing of the drying circuit from the outside.

[0015] A second seal, arranged inside the loading opening, mates with the internal diaphragm, isolating the section of the drying circuit leaving the rotating basket from the volume of the basket.

[0016] Advantageously, according to a further feature of the invention, the tank is provided with means which reduce to a minimum or eliminate the risk of overflows during handling of the tank.

[0017] The characteristics and advantages of the invention will emerge more clearly from the description below of a preferred embodiment and its two variantes, with reference to the attached drawings, in which:

Figure 1 is a view in anteroposterior section of a preferred embodiment of a front-loading laundry-drying machine with a panel-type closing door and a tank for collecting condensation water accommodated in the door, including likewise in diagrammatic form, for clarity and completeness of the description, the drying circuits and the functional machine components known per se;

Figure 2 is a partially exploded perspective view, with the door open, of the laundry-drying machine in Fig. 1;

Figure 3 is a diagrammatic view in anteroposterior section of the collecting tank for the machine in Figs 1 and 2, provided with means of reducing to a minimum the risk of overflow, which consist of an internal tube which limits the filling level of the tank;

Figure 4 is a diagrammatic view in anteroposterior section of a collecting tank for the machine in Figs 1 and 2, provided with means of eliminating completely the risk of overflow, which consist of a siphon which limits the filling and partial emptying level of the tank;

Figure 5 is a diagrammatic view in anteroposterior section of a collecting tank provided with means of eliminating the risk of overflow, with the formation inside the tank of a pressurization volume, which can be depressurized by the removal of the tank, and

Figure 6 is a partial exploded perspective view with the door open of an alternative embodiment of the laundry-drying machine in Figs 1 and 2.

[0018] With reference to Fig. 1, the laundry-drying machine comprises essentially a rotating drum or basket 1 which holds the laundry, is set in rotation by a motor 2 and passed through by a flow of air which is introduced

into the drum 1 by a centrifugal fan 3 and is subject to heating by heating elements 4.

[0019] The laundry contained in the drum 1 releases, by evaporation, the humidity which it contains to the flow of hot air. The hot humid air leaves the drum through a filter 5 (which retains flying down and fluff) and is conveyed by an appropriate pipe entering a condenser 6 which is cooled by a flow of relatively cold air drawn in from the atmosphere by means of a centrifugal aspirator 7.

[0020] In the condenser 6, the vapour contained in the flow of hot air is condensed to liquid by cooling and collects in a condenser reservoir 8 arranged below the level of a door for closing the loading opening, while the dehumidified air leaving the condenser 6 is drawn by the fan 3 and made to recirculate in the drum 1, subject to reheating.

[0021] The flow of ambient air used for the condensation is on the other hand dispersed into the atmosphere.

[0022] The condensation liquid collected in the reservoir 8 is conveyed, by means of a pump 9, into a collecting tank 10 which is arranged at a higher level relative to that of the condenser.

[0023] A level sensor 11, for example of the pressure-switch type, acts if the level of liquid in the reservoir exceeds a predetermined value, stopping the operation of the machine.

[0024] The operation of the machine is controlled by a programmer 12 which is actuated by buttons or knobs 13 arranged on a front control panel 14.

[0025] All these elements are accommodated in a piece of furniture provided with a front wall 15, in which a loading opening opens, which is closed by a door.

[0026] The innovative features of the present invention will now be considered with reference to both Figures 1 and 2.

[0027] The loading opening 16 in the front wall is defined by a collar 17 which extends internally from the front wall 15 to be connected, by a labyrinth seal, to a front rim 18 of the rotating drum 1.

[0028] In the lower wall of the collar, aspiration openings 19 open, which are connected to an aspiration pipe 20 which conveys the humid air leaving the rotating drum to the condenser 6.

[0029] In the upper part of the collar, there opens freely, in other words without any device for valve-type closing or sealed connection to the tank, a nozzle 21 for discharge of the condensation water which the pump 9 draws from the condenser reservoir 8.

[0030] The external edge and the internal edge of the collar are expediently provided with a resilient seal 22, 23 respectively.

[0031] The door for closing the loading opening, which is hinged on the front wall, is formed by a flat external front panel 24 and by an internal counter-panel 25 which has a flat frame which, when the door is closed, is juxtaposed to the seal 22 bringing about the sealed closing of the loading opening. The counter-panel forms

a sleeve 26 which projects internally and is accommodated in the collar of the loading opening and the external wall of which is juxtaposed, when the door is closed, to the seal 23.

[0032] Formed inside the sleeve is a housing 27 or containing cassette, which is generally cylindrical but can be prismatic, for a tank 10 for collecting the condensation water, which can be removed from the cassette in the direction of the housing axis represented by the arrow 28 and inserted by translation in the opposite direction.

[0033] On the uppermost edge of the sleeve 26 (or on one side), a perforated cover 29 is hinged, which constitutes a separation diaphragm between the internal volume of the rotating drum 1 and the cylindrical housing 27 to prevent the penetration of the laundry to be dried into the housing 27 during operation of the machine.

[0034] Inside the cover 29, which is provided to this end with a containing frame, a filter 5 for catching the down and fluff shed by the laundry is removably engaged.

[0035] The filter 5 is expediently provided with a knob 31 or equivalent means for its extraction from the cover 29 in the direction represented by the arrow 32.

[0036] Expediently, the knob 31 also serves as a spacer and, by bearing against the wall of the tank 10, ensures the formation, between filter and tank, of an air chamber, through which the hot humid air which passes through the filter can flow towards the aspiration pipe 20, through expedient openings 34 formed in the lower wall of the sleeve.

[0037] The sleeve 26 is provided on its upper wall with a funnel-shaped opening 33 which brings the outside of the sleeve into communication with the internal housing 27 and, when the door is closed, faces the nozzle 21 for discharge of the condensation water.

[0038] Provided in the lower wall of the sleeve, as already mentioned, are similar openings 34 which, when the door is closed, face the aspiration pipe 20.

[0039] The tank 10 is expediently provided with a handle 35 for extraction/insertion and, on its upper face, with a filling mouth 36 which, when the tank is inserted in its housing, is juxtaposed freely, in other words without any device for valve-type closing or sealed connection to a delivery pipe, to the funnel-shaped opening 33.

[0040] The filling mouth therefore functions jointly as a filling opening and a vent opening and prevents the tank becoming pressurized during filling.

[0041] Expediently, the tank 10 is provided on one side and on the upper wall with a recessed groove 37 which extends from the filling mouth 36 to the lower wall of the tank in such a manner that, when the tank is full, the excess liquid conveyed into the tank can freely overflow from the mouth 36 and flow along the groove 37 to the lower wall of the sleeve 26 where, passing through the openings 34, it is conveyed into the condenser 6 and discharged into the reservoir 8.

[0042] The operation of the laundry-drying machine

described is very simple: by opening the loading door, the operator can insert the laundry to be dried into the rotating drum, check that the filter 5 is clean and, if necessary, clean it by opening the cover 29 and removing the filter independently of the tank.

[0043] It is also possible to check that the tank 10, expediently made to this end of transparent material, is empty and, if necessary, remove it and empty it.

[0044] When the tank has been reinserted into its housing, the filter has been reinserted into the cover 29 and the cover has been reclosed, the door can be reclosed and the operation of the drier can be started.

[0045] If, as a result of this, the condensation liquid which is conveyed to the tank exceeds the accumulation volume available, for example as a result of omitting to empty the tank beforehand, the overflow of liquid which is conveyed into the condenser reservoir brings about the action of the pressure-switch protection and stopping of the machine. It is not necessary to provide other safety systems apart from those essential to a conventional laundry-drying machine.

[0046] If, by lack of attention, the operator omits to insert the tank in its housing, the condensation liquid leaving the nozzle 21 is discharged into the housing 27 and, conveyed back into the condenser reservoir, brings about the action of the protection, in the same manner, at the very beginning of the drying operation.

[0047] The operator, alerted by the action of the protection, can easily recognize, by opening the loading door, the full state of the tank or its absence from the housing.

[0048] The structure of the machine is therefore very simple and extremely reliable and at the same time particularly ergonomic and convenient to operate.

[0049] The removability of the filter independently of the collecting tank allows it to be handled easily, unaffected by the weight of the tank, for thorough cleaning, if necessary under a jet of water, without risk of damage.

[0050] At the same time, the removal of the tank for emptying can be carried out without special precautions, except those which are necessary in order to avoid any overflows if the tank is completely full.

[0051] Figures 3, 4 and 5 represent a number of measures which reduce to a minimum or eliminate the risk of any overflows during removal of the tank.

[0052] In Fig. 3, the tank 10 is provided internally with an overflow tube 40 which is open on the lower wall of the tank and the top of which ends close to the handle 35 for extracting the tank from its housing. Since the handle is eccentric relative to the barycentric vertical axis of the tank, the tank tends, during its removal from the cassette housing, to rotate slightly to be arranged with its barycentre vertically aligned with the gripping handle.

[0053] As a result of this rotation, the upper part of the liquid contained in the tank tends to move away from the upper mouth of the overflow tube 40 so that possible overflows from the overflow tube are avoided.

[0054] As illustrated in Fig. 4, the overflow tube 40 can

advantageously be replaced by a siphon 41 which comes into action when the level of the liquid in the tank reaches the threshold 42 of the siphon and brings about the partial emptying of the tank to the level of the mouth 43 for feeding the siphon.

[0055] Alternatively, as illustrated in Fig. 5, the mouth 36 for filling the tank 10 is provided with a funnel-shaped sleeve 44 which penetrates a convenient depth into the tank.

[0056] When the level of the liquid in the tank reaches the lower edge 45 of the funnel-shaped sleeve 44, a volume of air is formed in the upper part of the tank, which is pressurized by any further liquid supply and prevents complete filling of the tank.

[0057] The maximum pressurization which can be exerted is determined in terms of water column, by the difference between the overflow level of the mouth 36 and the filling level of the tank.

[0058] By providing a vent opening 46, which is normally closed when the tank 10 is correctly installed in its housing by a resilient plug 47 arranged in the housing, on the first movement of the tank 10 for its removal, the opening 46 is opened, drawing back into the tank the liquid contained in the sleeve 44.

[0059] Alternatively, as shown in Fig. 2, the resilient plug 47 can be mounted on the filter 5 and the vent 46 can be provided on the wall of the tank facing the filter in such a manner that opening the cover 29 brings about opening of the vent, still before the tank is removed from its housing.

[0060] Fig. 6 represents an alternative embodiment of the laundry-drying machine in Figs 1 and 2, in which, inside the front closing door, the counter-panel 25 forms a cassette 27 or pocket housing for the tank and filter, which is open at the top.

[0061] In this case, the perforated diaphragm 50 for closing the cassette is an integral part and steady with the counter-panel itself.

[0062] The filter 5, provided with a spacing frame 30 and an upper handle 48, is arranged in the cassette 27 in an interposed position between the perforated diaphragm 50 and the tank 10 which is provided with an upper handle 49 and a filling mouth 36.

[0063] The tank is expediently shaped to allow its removal from the cassette by slight rotation and translation upwards, subject to removal of the filter 30, so as to utilize (as in the case of Figs 1 and 2) the volume offered by the thickness of the closing door.

[0064] Since the removal of the tank 10 is subject to the removal of the filter, the further advantage is achieved that the filter is inspected upon each operation to remove the tank, avoiding subsequent disadvantages (reduction of the drying efficiency, greater wear of the fan and overheating of the recirculation air).

[0065] All the other features of the laundry-drying machine are unchanged and are therefore not discussed. It is clear that all the overflow measures already described can be applied to the tank.

Claims

1. Laundry-drying machine with a front door (24, 25, 26) formed by a flat external panel (24) for closing the loading opening (16) and by an internal counter-panel (25), and a tank (10) for collecting condensate accommodated in said door (24, 25, 26), said laundry-drying machine being provided with a rotating drum (1) for containing the laundry and with a condenser (6) reservoir (8) arranged below the level of said front door, comprising:
- a nozzle (21), for supplying condensation water, which is freely open in said loading opening (16),
 - a cassette (27) for housing a collecting tank (10), which cassette is formed in said internal counter-panel (25), provided at the top with an opening (33) which, when the door is closed, faces said nozzle (21),
 - a tank (10) for collecting condensation water, which is accommodated in said cassette (27) and can be removed from said cassette only when the door is open, said tank (10) being provided, on its upper face, with a filling mouth (36) which freely faces said supply nozzle (21), when said front door is closed,
 - a perforated diaphragm (29, 47, 50) associated with said cassette (27) to separate the volume of said drum (1) from the volume of said cassette (27), and
 - a filter (5) for catching fluff, which is accommodated in said cassette (27), interposed between said tank (10) and said diaphragm (29, 47, 50),

characterized in that

said cassette (27) is provided at the bottom with means (34, 20) capable of conveying an overflow of liquid into said condenser reservoir (8) by gravity, and **in that**

the filter (5) can be removed from the cassette (27) independently from said tank (10) only when the door is open.

2. Laundry-drying machine according to Claim 1, in which said internal counter-panel (25) forms a sleeve (26) inside which said cassette (27) is formed, said diaphragm (29) is hinged on an edge of the sleeve (26) in order to assume a position for closing said cassette and a position in which the cassette is open, and said filter (5) is mounted removably on the inside of said diaphragm (29) and can be removed when the door is open, and in which:

said tank (10) can be extracted from said cassette in a direction perpendicular to the flat surface of said panel (24), in said opening position

of said cassette (27).

3. Laundry-drying machine according to Claim 1, in which said cassette housing (27) is open at the top and said filter (5) and said tank (10) can be extracted separately from said cassette by translation upwards.
4. Laundry-drying machine according to Claim 3, in which said tank (10) can be extracted from said cassette housing (27) only subject to extraction of said filter (5) from said cassette.
5. Laundry-drying machine according to Claims 1, 2, 3 or 4, in which said tank (10) is provided internally with an overflow tube (40) which is open at the bottom of said tank (10).
6. Laundry-drying machine according to Claims 1, 2, 3 or 4, in which said tank (10) is provided with an internal siphon (41) for overflow and partial emptying, which is open at the bottom of said tank (10).
7. Laundry-drying machine according to Claims 1, 2, 3 or 4, in which said tank (10) is provided with means (44) of pressurization of a volume at the top of said tank, and with means (46) of depressurization of said volume at the top, which can be actuated on removal of said tank (10) from said cassette.

Patentansprüche

1. Wäschetrockner mit einer Fronttür (24, 25, 26), die durch eine flache Außenplatte (24) zum Verschließen der Ladeöffnung (16) und durch eine innere Gegenplatte (25) gebildet ist, und mit einem Behälter (10) zum Sammeln von Kondensat, der in der Tür (24, 25, 26) untergebracht ist, wobei der Wäschetrockner mit einer rotierenden Trommel (1) für die Aufnahme der Wäsche und mit einem Kondensatspeicher versehen ist, der unterhalb der Ebene der Fronttür positioniert ist, mit folgenden weiteren Merkmalen:
- einer Düse (21) zum Zuführen von Kondensatwasser, die in die Ladeöffnung (16) offen hineinragt,
 - einer Kassette (27) für die Aufnahme eines Sammelbehälters (10), die in der inneren Gegenplatte (25) ausgeformt ist, und die an ihrer Oberseite eine Öffnung (33) aufweist, die bei geschlossener Tür mit der Düse (21) fluchtet,
 - einem Behälter (10) zum Sammeln von Kondensatwasser, der in der Kassette (27) untergebracht ist und nur bei offener Tür von der Kassette (27) entfernt werden kann, wobei der Behälter (10) an seiner Oberseite mit einem

- Befüllmund (36) versehen ist, der bei geschlossener Fronttür mit der Zufühdüse (21) fluchtet,
- einem perforierten Boden (29, 47, 50), der der Kassette (27) zum Trennen des Inhaltes der Trommel (1) von dem Inhalt der Kassette (27) zugeordnet ist, und
 - einem Filter (5) zum Auffangen von Flusen, der in der Kassette (27) untergebracht und zwischen dem Behälter (10) und dem Boden (29, 47, 50) angeordnet ist,

dadurch gekennzeichnet, dass

die Kassette (27) an ihrem Boden mit Mitteln (34, 20) versehen ist, die überlaufende Flüssigkeit durch Schwerkraft in den Kondensatspeicher (8) leiten, und dass der Filter (5) unabhängig von dem Behälter (10) nur bei offener Tür von der Kassette (27) entfernt werden kann.

2. Wäschetrockner nach Anspruch 1, wobei die innere Gegenplatte (25) eine Muffe (26) bildet, innerhalb der die Kassette (27) ausgebildet ist, wobei der Boden (29) an einer Kante der Muffe (26) angeschlagen ist, um eine die Kassette schließende und eine die Kassette freigebende Position einnehmen zu können, und wobei der Filter (5) lösbar an der Innenseite des Bodens (29) befestigt ist und bei offener Tür entfernt werden kann, und wobei der Behälter (10) aus der Kassette rechtwinklig zu der flachen Oberfläche der Platte (24) in der Öffnungsposition der Kassette herausgezogen werden kann.
3. Wäschetrockner nach Anspruch 1, bei dem das Kassettengehäuse (27) an seiner Oberseite offen ist und der Filter (5) und der Behälter (10) jeweils separat durch eine Aufwärtsbewegung aus der Kassette herausgenommen werden können.
4. Wäschetrockner nach Anspruch 3, bei dem der Behälter (10) aus dem Kassettengehäuse (27) nur gemeinsam mit dem Filter (5) herausgenommen werden kann.
5. Wäschetrockner nach Anspruch 1, 2, 3 oder 4, bei dem der Behälter (10) innen mit einem Überlaufrohr (40) versehen ist, das am Boden des Behälters (10) offen ist.
6. Wäschetrockner nach Anspruch 1, 2, 3, oder 4, bei dem der Behälter (10) mit einem Innensiphon (41) für Überlauf und teilweises Entleeren versehen ist, der am Boden des Behälters (10) offen ist.
7. Wäschetrockner nach Anspruch 1, 2, 3, oder 4, bei dem der Behälter (10) mit Mitteln (44) zum Unterdrucksetzen eines Raumes im oberen Bereich des Behälters und mit Mitteln (46) zum Belüften des Raumes in dem oberen Bereich versehen ist, die

bei einem Entfernen des Behälters (10) von der Kassette aktiviert werden können.

5 **Revendications**

1. Sèche-linge pourvu d'une trappe avant (24, 25, 26) formée par un panneau externe plat (24) destiné à fermer l'ouverture de chargement (16) et par un contre-panneau interne (25), et d'un réservoir (10) destiné à collecter le condensat et reçu dans la dite trappe (24, 25, 26), le dit sèche-linge étant équipé d'un tambour tournant (1) destiné à contenir le linge et d'un réservoir (8) de condenseur (6) qui est disposé au-dessous du niveau de la dite trappe avant, comprenant :

- une buse (21), destinée à amener l'eau de condensation, qui débouche librement dans la dite ouverture de chargement (16),
- une cassette (27) destinée à loger un réservoir de collecte (10), laquelle cassette est formée dans le dit contre-panneau interne (25), pourvue à la partie supérieure d'une ouverture (33) qui, quand la trappe est fermée, fait face à la dite buse (21),
- un réservoir (10) destiné à collecter l'eau de condensation, qui est reçu dans la dite cassette (27) et qui peut être retiré de la dite cassette uniquement lorsque la trappe est ouverte, le dit réservoir (10) étant équipé, sur sa face supérieure, d'une embouchure de remplissage (36) qui fait librement face à la dite buse d'amenée (21), lorsque la dite trappe avant est fermée,
- un diaphragme perforé (29, 47, 50) associé à la dite cassette (27) afin de séparer le volume du dit tambour (1) du volume de la dite cassette (27), et
- un filtre (5) destiné à piéger les peluches, qui est reçu dans la dite cassette (27), interposé entre le dit réservoir (10) et le dit diaphragme (29, 47, 50),

caractérisé en ce que

la dite cassette (27) est pourvue, à la partie inférieure, de moyens (34, 20) aptes à acheminer un trop-plein de liquide dans le dit réservoir (8) de condenseur par gravité,

et en ce que

le filtre (5) peut être retiré de la cassette (27) indépendamment du dit réservoir (10) uniquement lorsque la trappe est ouverte.

2. Sèche-linge selon la revendication 1, dans lequel le dit contre-panneau interne (25) forme un manchon (26) à l'intérieur duquel la dite cassette (27) est formée, le dit diaphragme (29) est mis en articulation sur un bord du manchon (26) de manière à prendre

une position qui permette la fermeture de la dite cassette et une position dans laquelle la cassette est ouverte, et le dit filtre (5) est monté, de façon amovible, sur l'intérieur du dit diaphragme (29) et peut être retiré lorsque la trappe est ouverte, et dans lequel :

le dit réservoir (10) peut être extrait de la dite cassette suivant une direction perpendiculaire à la surface plate du dit panneau (24), dans la dite position d'ouverture de la dite cassette (27).

3. Sèche-linge selon la revendication 1, dans lequel le dit logement de cassette (27) est ouvert à la partie supérieure et le dit filtre (5) et le dit réservoir (10) peuvent être extraits séparément de la dite cassette par mouvement de translation vers le haut. 15
4. Sèche-linge selon la revendication 3, dans lequel le dit réservoir (10) peut être extrait du dit logement de cassette (27), à la condition unique que le dit filtre (5) soit extrait de la dite cassette. 20
5. Sèche-linge selon la revendication 1, 2, 3 ou 4, dans lequel le dit réservoir (10) est équipé, à l'intérieur, d'un tube de trop-plein (40) qui est ouvert à la partie inférieure du dit réservoir (10). 25
6. Sèche-linge selon la revendication 1, 2, 3 ou 4, dans lequel le dit réservoir (10) est équipé d'un siphon interne (41) destiné au trop-plein et à la vidange partielle, qui est ouvert à la partie inférieure du dit réservoir (10). 30
7. Sèche-linge selon la revendication 1, 2, 3 ou 4, dans lequel le dit réservoir (10) est équipé de moyens (44) de mise sous pression d'un volume à la partie supérieure du dit réservoir, et de moyens (46) de dépressurisation du dit volume à la partie supérieure, qui peuvent être actionnés lors du retrait du dit réservoir (10) de la dite cassette. 35 40

45

50

55

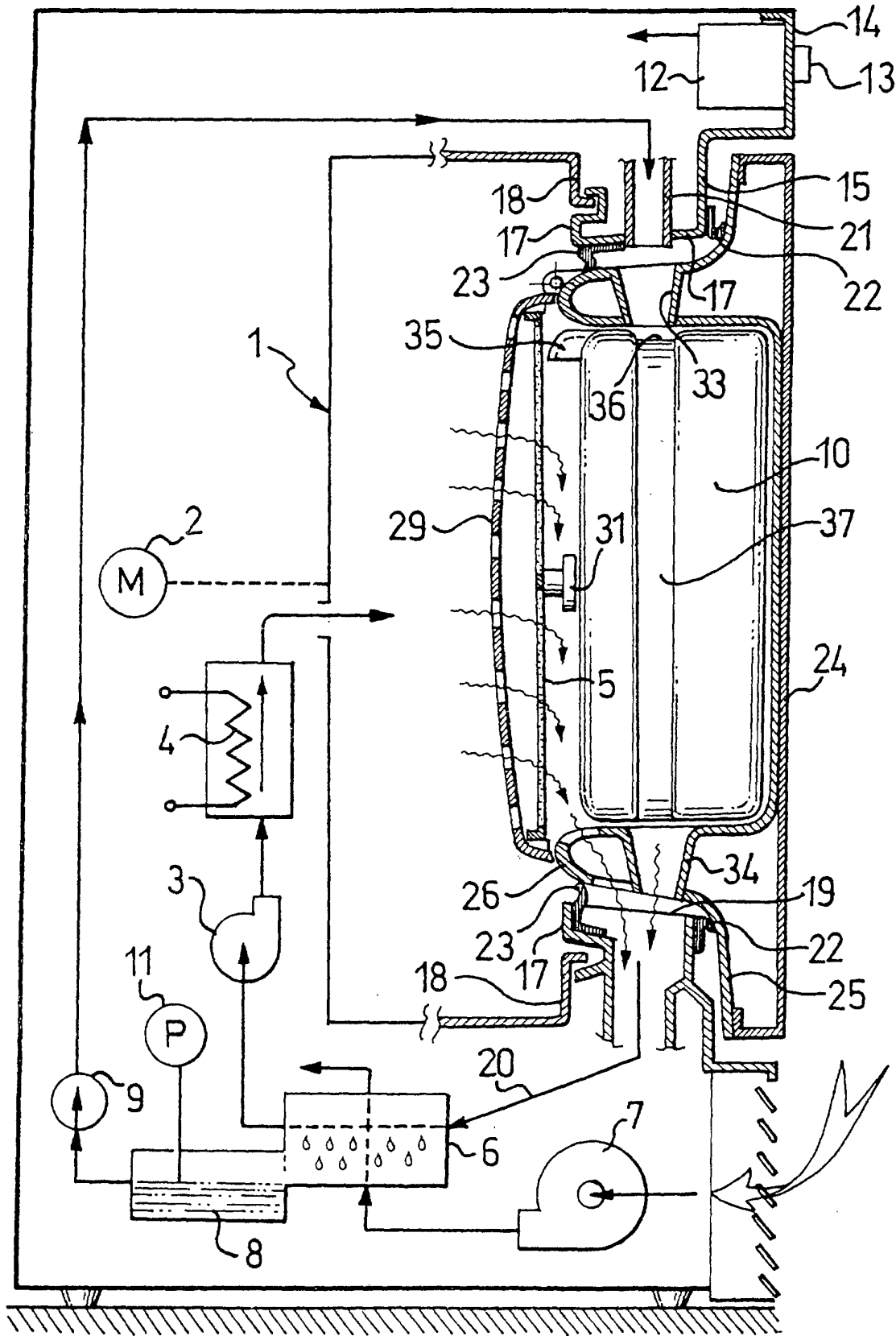

FIG.1

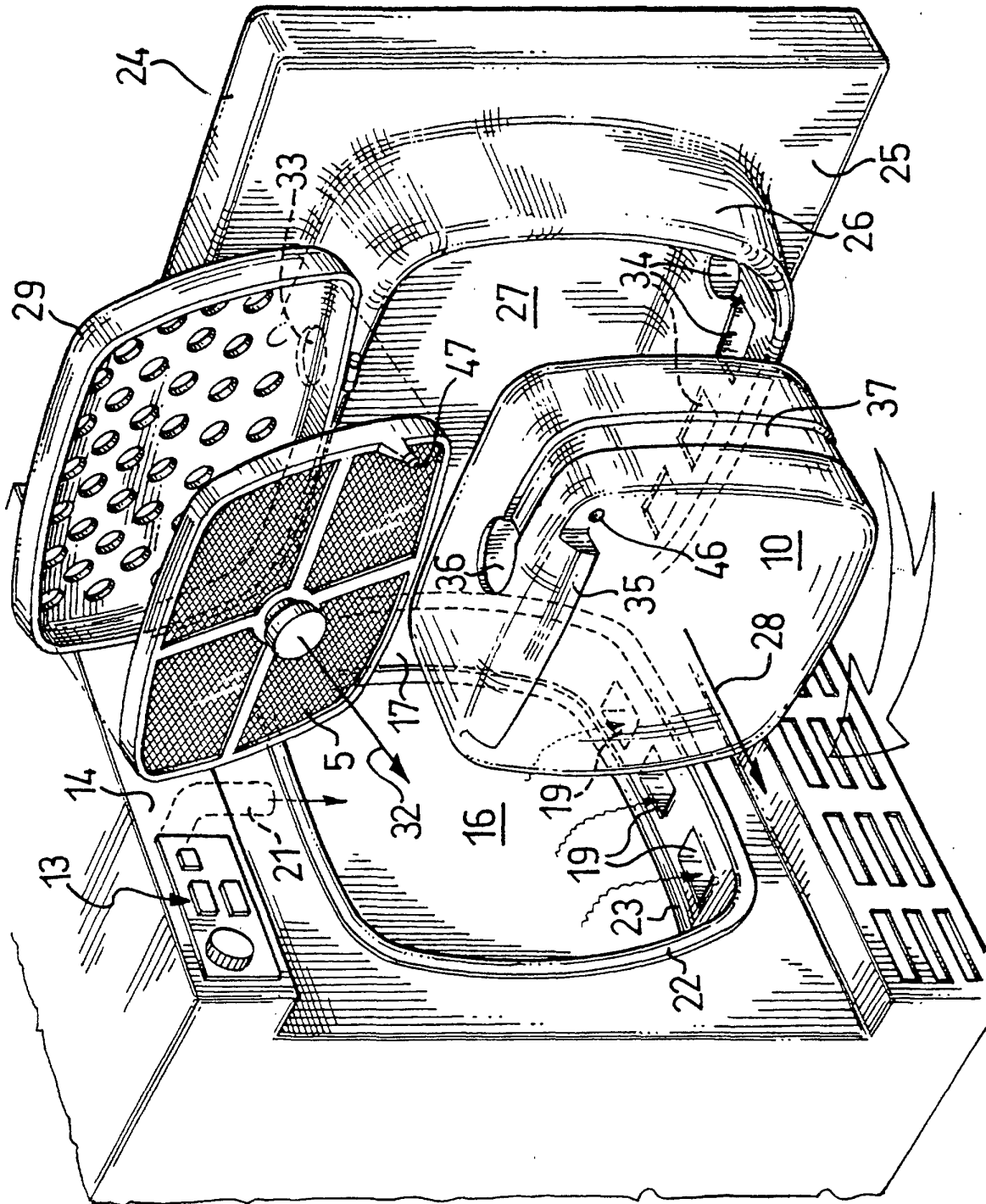

FIG. 2

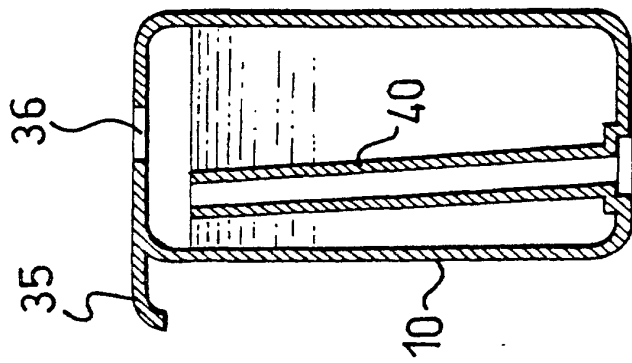

FIG. 3

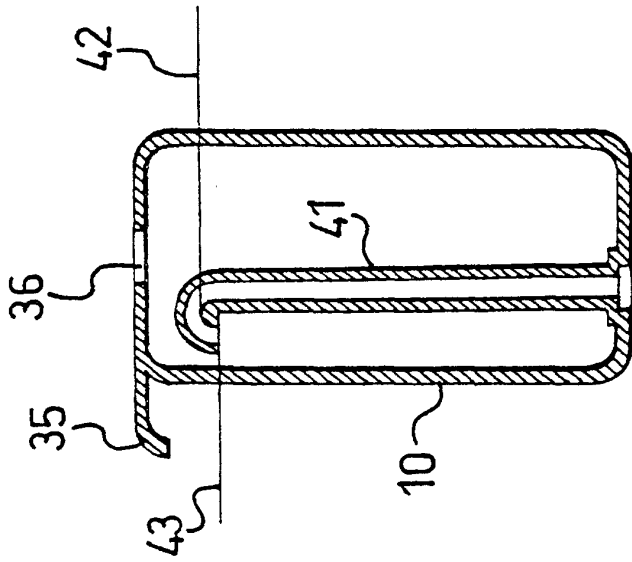

FIG. 4

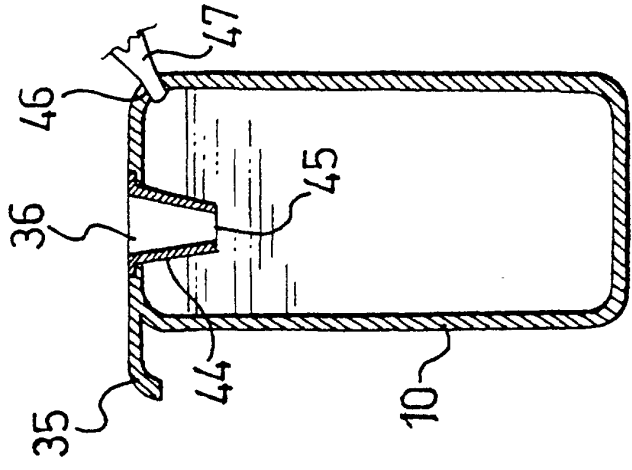

FIG. 5

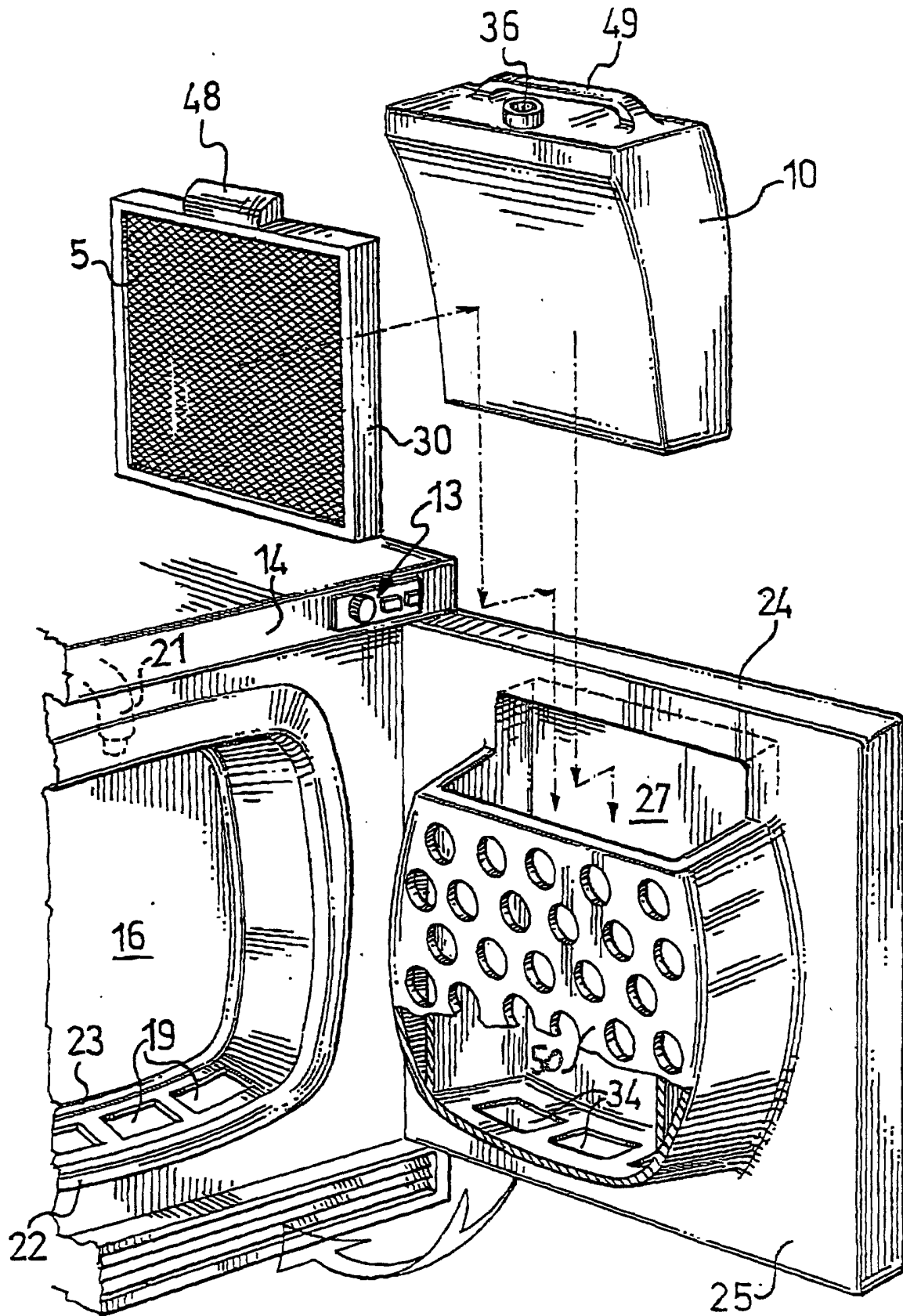

FIG. 6