

(19) World Intellectual Property Organization
International Bureau



(43) International Publication Date
14 November 2002 (14.11.2002)

PCT

(10) International Publication Number
WO 02/091765 A2

(51) International Patent Classification⁷: H04Q 7/22

(74) Agents: GRAZIANO, James, M. et al.; Patton Boggs LLP, P. O. Box 270930, Louisville, CO 80027-5015 (US).

(21) International Application Number: PCT/US01/49700

(81) Designated States (national): AE, AG, AL, AM, AT, AU, AZ, BA, BB, BG, BR, BY, BZ, CA, CH, CN, CO, CR, CU, CZ, DE, DK, DM, DZ, EC, EE, ES, FI, GB, GD, GE, GH, GM, HR, HU, ID, IL, IN, IS, JP, KE, KG, KP, KR, KZ, LC, LK, LR, LS, LT, LU, LV, MA, MD, MG, MK, MN, MW, MX, MZ, NO, NZ, PH, PL, PT, RO, RU, SD, SE, SG, SI, SK, SL, TJ, TM, TR, TT, TZ, UA, UG, UZ, VN, YU, ZA, ZW.

(22) International Filing Date:
28 December 2001 (28.12.2001)

(25) Filing Language: English

(26) Publication Language: English

(30) Priority Data:
09/853,142 9 May 2001 (09.05.2001) US

(84) Designated States (regional): ARIPO patent (GH, GM, KE, LS, MW, MZ, SD, SL, SZ, TZ, UG, ZM, ZW), Eurasian patent (AM, AZ, BY, KG, KZ, MD, RU, TJ, TM), European patent (AT, BE, CH, CY, DE, DK, ES, FI, FR, GB, GR, IE, IT, LU, MC, NL, PT, SE, TR), OAPI patent (BF, BJ, CF, CG, CI, CM, GA, GN, GQ, GW, ML, MR, NE, SN, TD, TG).

(71) Applicant: VESUVIUS, INC. [US/US]; 1252 Pintail Circle, Boulder, CO 80303 (US).

(72) Inventors: MCKENNA, Daniel, B.; 2650 Windward Way, Steamboat Springs, CO 80487 (US). GRAZIANO, James, M.; 4662 Weld County Road 34, Platteville, CO 80651 (US).

Declarations under Rule 4.17:
— as to applicant's entitlement to apply for and be granted a patent (Rule 4.17(ii)) for all designations

[Continued on next page]

(54) Title: COMMUNIQUE SYSTEM FOR VIRTUAL PRIVATE NARROWCASTS IN CELLULAR COMMUNICATION NETWORKS

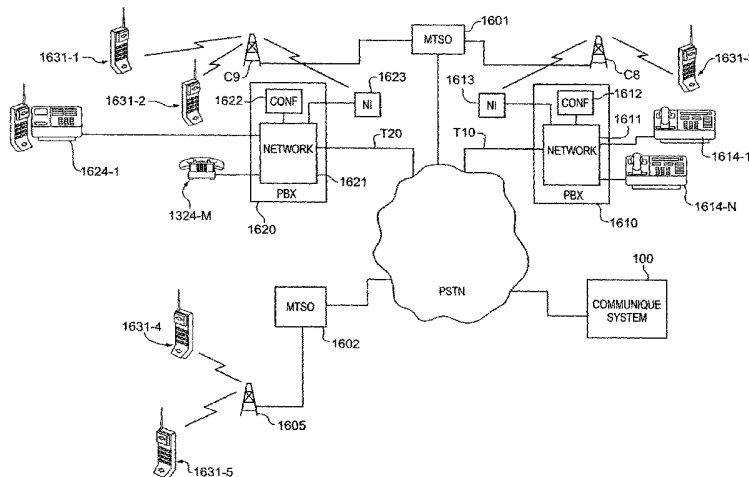

(57) Abstract: The communiqué system for private virtual narrowcasts operates with existing cellular communication networks to provide private virtual narrowcast communication services, that are initiated by a narrowcast host, to subscribers. The Communiqué can be unidirectional (broadcast) or bi-directional (interactive) in nature and the extent of the Communiqué is narrowcast, where cells and/or cell sectors are grouped to cover a predetermined geographic area or demographic population or subscriber interest group to transmit information to a private group of subscribers who populate the target audience for the narrowcast transmissions. The grouping of cells to form the communiqué coverage area for the narrowcast transmissions need not be contiguous. The private virtual narrowcasts use the code, frequency and time domains to enable multiple users to share the same wireless resource in a manner that, from the users perspective, has dedicated spectrum or channel capacity to their particular application.



WO 02/091765 A2



— *as to the applicant's entitlement to claim the priority of the earlier application (Rule 4.17(iii)) for all designations*

For two-letter codes and other abbreviations, refer to the "Guidance Notes on Codes and Abbreviations" appearing at the beginning of each regular issue of the PCT Gazette.

Published:

— *without international search report and to be republished upon receipt of that report*

COMMUNIQUE SYSTEM FOR VIRTUAL PRIVATE NARROWCASTS IN CELLULAR COMMUNICATION NETWORKS

Field of the Invention

5 This invention relates to cellular communication networks and to a communiqué system that makes use of the bandwidth capacity in existing point-to-point cellular communication networks to provide subscribers with access to a plurality of broadcast and narrowcast based services.

Problem

10 It is a problem in cellular communication networks that the network topology is exclusively point to point in nature. This paradigm represents the historical view of cellular communications as a wireless equivalent of traditional wire-line telephone communication networks, which serve to interconnect a calling party with a called party. An additional problem in cellular communication networks is that the need to
15 concurrently serve many voice subscribers with the limited bandwidth available in cellular communication networks has prevented the provision of wide bandwidth communication services, such as data, to these subscribers.

The third generation (3G) wireless communication systems, as specified by the ITU/IMT-2000 requirements for cellular communications, represent a step toward
20 solving the above-noted problems. The third generation wireless communication systems support the provision of advanced packet data services. In 3G/IMT-2000 systems, dynamic Internet Protocol address assignment is required in addition to static Internet Protocol (IP) address assignment. With static IP address assignment, the wireless subscriber station's static IP address is fixed and assigned by the home
25 wireless network. When the wireless subscriber station is away from its home wireless network (roaming), a special data communications link (Wireless IP tunnel) needs to be established between the visited wireless network and the home wireless network. In this case, IP packets destined to the wireless subscriber station's IP address of the home wireless network are routed to the home wireless network according to standard
30 IP routing. A Wireless IP tunnel is used in the home wireless network to redirect the IP packets that are destined to the wireless subscriber station's static IP address to the visited wireless network where the roaming wireless subscriber station is located and being served. When a wireless subscriber station moves from one wireless network coverage area to another, Wireless IP mobility binding updates are performed between
35 the wireless subscriber station and its Home Agent (HA) in the home wireless network. Since both the wireless station's IP address and its Home Agent IP address are static or fixed, a shared secret between the wireless subscriber station and the Home Agent

can be preprogrammed into the wireless station and its Home Agent so that the Home Agent can authenticate Wireless IP registrations requested by the wireless subscriber station and perform mobility binding updates in a secure manner.

5 However, even with advances in bandwidth utilization and the provision of packet data services, the cellular communication networks still operate on a point to point paradigm, with the networks being unable to concurrently communicate data to a plurality of subscribers, which is the fundamental concept of broadcast communications, especially in the case of a dynamically changing audience for the broadcasts.

Solution

10 The above described problems are solved and a technical advance achieved by the communiqué system for private virtual narrowcasts that operates with existing cellular communication networks to provide private virtual narrowcast communication services, that are initiated by a narrowcast host, to subscribers. The Communiqué transported by this system can be unidirectional or bi-directional (interactive) in nature
15 and the extent of the Communiqué is narrowcast, where cells and/or cell sectors are grouped to cover a predetermined geographic area or demographic population or subscriber interest group to transmit information to a private group of subscribers who populate the target audience for the narrowcast transmissions. The grouping of cells to form the communiqué coverage area for the narrowcast transmissions need not be
20 contiguous and can comprise dynamic combinations of contiguous and non-contiguous cells as well as combinations of in-building wireless coverage areas, standard terrestrial cells, non-terrestrial cells, orchestrated in a hierarchical manner. The private virtual narrowcasts use the code, frequency and time domains to enable multiple users to share the same wireless resource in a manner that, from the users perspective, has
25 dedicated spectrum or channel capacity to their particular application. The applications can include asymmetric bi-directional communications where private virtual narrowcasts are the stimulus for point-to-point responses from subscriber terminal devices.

The content of these communiqué transmissions can be multi-media in nature and comprise a combination of various forms of media: audio, video, graphics, text,
30 data and the like. The subscriber terminal devices used to communicate with the communiqué system for private virtual narrowcasts are typically full function communication devices that include: standard cellular telephones, WAP enabled cellular telephones, personal digital assistants, Palm Pilots, personal computers, and the like or special communiqué only communication devices that are specific to

communiqué reception; or MP3 audio players (essentially a radio receiver or
communiqué radio); or an MPEG4 video receiver (communiqué TV); or other such
specialized communication device. The subscriber terminal devices used in the
communiqué system for private virtual narrowcasts can be mobile wireless
5 communication devices in the traditional mobile subscriber paradigm, or the fixed
wireless communication devices in the more recent wireless product offerings, or
wireline-based communication devices. Furthermore, the communiqué communication
services can be free services, subscription based services, or toll based services, while
the data propagation can be based on push, pull and combinations of push/pull
10 information distribution modes.

Brief Description of the Drawing

Figures 1A - 1C illustrate in block diagram form the overall architecture of typical
cellular and wireline communication networks that are equipped with the communiqué
system for private virtual narrowcasts;

15 Figure 2 illustrates in flow diagram form the operation of a typical cellular
communication system in implementing an idle handoff mode of operation;

Figure 3 illustrates in block diagram form a typical configuration of the base to
end user forward CDMA channel used in cellular communication networks;

20 Figure 4 illustrates in block diagram form a typical assignment of cells in a
cellular communication network for a unidirectional transmission without subscriber
registration mode of operation of the communiqué system for private virtual
narrowcasts;

Figure 5 illustrates in block diagram form a typical configuration of the base to
end user forward CDMA channel used in cellular communication networks;

25 Figure 6 illustrates in block diagram form a typical assignment of cells in a
cellular communication network as an example of the operation of the communiqué
system for private virtual narrowcasts;

30 Figure 7 illustrates in block diagram form a typical assignment of cells in a
cellular communication network for a non-interactive bi-directional transmission with
subscriber registration mode of operation of the communiqué system for private virtual
narrowcasts;

Figure 8 illustrates in block diagram form a typical signaling protocol for a Traffic
channel for use in the communiqué system for private virtual narrowcasts;

35 Figure 9 illustrates in block diagram form the overall architecture of a
communiqué wireless subscriber device;

Figure 10 illustrates in flow diagram form one mode of using subscriber information as active feedback in the operation of the communiqué system for private virtual narrowcasts;

5 Figure 11 illustrates in flow diagram form the operation of the Spatial-Temporal Content Manager;

Figure 12 illustrates a typical program coverage pattern;

Figure 13 illustrates a typical program stream for a plurality of communication channels;

10 Figure 14 illustrates in block diagram form the overall architecture of a communiqué wired subscriber device;

Figure 15 illustrates a plurality of cell sites and their coverage areas;

Figure 16 illustrates in block diagram form additional detail of a portion of the network configuration that supports the narrowcast coverage area described above;

15 Figure 17 illustrates in flow diagram form the operation of the communiqué system for private virtual narrowcasts in executing the multi-location narrowcast network operation described above;

Figure 18 illustrates in block diagram form a network configuration that supports a chat room-like service from the communiqué system for private virtual narrowcasts; and

20 Figure 19 illustrates in flow diagram form the operation of the communiqué system for private virtual narrowcasts in executing the distributed device control and utility meter reading application.

Detailed Description

Existing cellular communication networks are designed with a network topology
25 that is exclusively point to point in nature. This paradigm represents the historical view of cellular communications as a wireless equivalent of traditional wire-line telephone communication networks, which serve to interconnect a calling party with a called party. The need to concurrently serve many voice subscribers with the limited bandwidth available in cellular communication networks has also prevented the provision of wide
30 bandwidth communication services to these subscribers. These existing systems are largely static in their operation, with each cell providing point to point communications to a population of subscribers who reside in or roam into the predefined service area of the cell. There is an absence of a capability to provide a communication service to a subscriber population that comprises a dynamically changing coverage area that
35 spans multiple cells. The dynamic convergence of a plurality of subscribers to constitute a target audience for Communiqués is a paradigm that is not addressed by

existing cellular communication systems, nor is there any functionality suggested in existing cellular communication systems to deal with providing information relevant to this target audience in a real time manner.

Cellular Communication Network Philosophy

5 Cellular communication networks as shown in block diagram form in Figures 1A & 1B, provide the service of connecting wireless telecommunication customers, each having a wireless subscriber device, to both land-based customers who are served by the common Carrier Public Switched Telephone Network (PSTN) 108 as well as other wireless telecommunication customers. In such a network, all incoming and outgoing
10 calls are routed through Mobile Telephone Switching Offices (MTSO) 106, each of which is connected to a plurality of cell sites (also termed Base Station Subsystems 131-151) which communicate with wireless subscriber devices 101, 101' located in the area covered by the cell sites. The wireless subscriber devices 101, 101' are served by the cell sites, each of which is located in one cell area of a larger service region.
15 Each cell site in the service region is connected by a group of communication links to the Mobile Telephone Switching Office 106. Each cell site contains a group of radio transmitters and receivers (Base Station Transceiver 132, 142, 143, 152) with each transmitter-receiver pair being connected to one communication link. Each transmitter-receiver pair operates on a pair of radio frequencies to create a communication
20 channel: one frequency to transmit radio signals to the wireless subscriber device and the other frequency to receive radio signals from the wireless subscriber device.

The first stage of a cellular communication connection is set up when a transmitter-receiver pair in a cell site 131, operating on a predetermined pair of radio frequencies, is turned on and a wireless subscriber device 101, located in the cell site
25 131, is tuned to the same pair of radio frequencies to thereby activate a communication channel between the wireless subscriber device 101 and the cell site 131. The second stage of the communication connection is between the communication link connected to this transmitter-receiver pair and the common carrier Public Switched Telephone Network 108. This second stage of the communication connection is set up in the
30 Mobile Telephone Switching Office 106, which is connected to the common carrier Public Switched Telephone Network 108 by incoming and outgoing trunks.

The Mobile Telephone Switching Office 106 contains a switching network 106N to switch wireless subscriber voice and/or data signals from the communication link to an incoming or outgoing trunk. The Mobile Telephone Switching Office 106 and
35 associated software typically manages the base station controllers 132, 142, 152 and the Base Station Transceiver Transmit/Receive electronics which serve to implement the wireless radio frequency link to the wireless subscriber devices 101. The Mobile

Telephone Switching Office 106, in conjunction with the Home Location Register (HLR) 161 and the Visitor Location Register (VLR) 162, manages subscriber registration, subscriber authentication, and the provision of wireless services such as voice mail, call forwarding, roaming validation and so on. The Mobile Telephone Switching Office
5 Controller 106C also controls the actions of the associated base station controllers 132, 142, 152 by generating and interpreting the control messages that are exchanged with the associated base station controllers 132, 142, 152 over data links that interconnect these subsystems. The base station controllers 132, 142, 152 at each cell site 131-151, in response to control messages from the Mobile Telephone Switching Office 106,
10 control the transmitter-receiver pairs at the cell site 131. The control processes at each cell site also control the tuning of the wireless subscriber devices to the selected radio frequencies. In the case of CDMA, the system also selects the PN code word to enhance isolation of the communications with the wireless subscriber devices.

Each cell in the cellular communication network comprises a predetermined
15 volume of space radially arranged around the cell site transmitting antenna with the region of space roughly approximating a cylindrical volume having predetermined height. Since all of the wireless subscriber devices are installed in ground-based units (such as motor vehicles or handheld units) in traditional cellular communication systems, the antenna radiation pattern of the cell site is aligned to be proximate to the
20 ground and the polarization of the signals produced by the cell site antenna is vertical in nature. In order to prevent the radio signals in one cell site from interfering with radio signals in an adjacent cell site, the transmitter frequencies for adjacent cell sites are selected to be different so that there is sufficient frequency separation between adjacent transmitter frequencies to avoid overlapping transmissions among adjacent
25 cell sites. In order to reuse the same frequencies, the cellular telecommunication industry has developed a small but finite number of transmitter frequencies and a cell site allocation pattern that ensures that two adjacent cell sites do not operate on the same frequency. When a ground-based wireless subscriber device initiates a call connection, control signals from the local cell site transmitter cause the frequency agile transponder in the ground-based wireless subscriber device to operate at the frequency
30 of operation designated for that particular cell site. As the ground-based wireless subscriber device moves from one cell site to another, the call connection is handed off to the successive cell sites and the frequency agile transponder in the ground-based wireless subscriber device adjusts its frequency of operation to correspond to the
35 frequency of operation of the transmitter located in the cell site in which the ground-based wireless subscriber device is presently operational.

There are numerous technologies that can be used to implement the cellular communication network and these include both digital and analog paradigms, with the digital apparatus representing the more recent of the two technologies. Furthermore, the frequency spectrum is allocated for different cellular communication systems, with the personal communication system (PCS) systems being located in the 1.9 GHz region of the spectrum while traditional cellular systems are located in the 800 MHz region of the spectrum. The access methods used in cellular communication systems include Code Division Multiple Access (CDMA) that uses orthogonal codes to implement communication channels, Time Division Multiple Access (TDMA) which uses time division multiplexing of a frequency to implement communication channels and Frequency Division Multiple Access (FDMA) which uses separate frequencies to implement communication channels, as well as combinations of these technologies.

There is also a HDR (High Data Rate) service, also called 1xEV or 1xEV-DO (1x Evolution-Data Only), which comprises a 2.4 Mbps communication architecture. This service uses a CDMA carrier but acts like TDMA from the user's perspective, with TCP/IP as the application layer protocol. The HDR service is one-one in format and bi-directional in communication mode. On the forward path, base to mobile, the HDR service only communicates with any one end-user at any given time, allocating the entire 2.4 Mbps bandwidth to that end user. It then bursts the next forward path transmission to the next end-user. The reverse path is contention based. This architecture takes advantage of the group traffic profile of multiple users who are surfing the web wirelessly. These concepts are well known in the field of cellular communications and various ones of these can be used to implement the ubiquitous wireless subscriber device of the present invention. These technologies are not limitations to the system which is described herein, since a novel system concept is disclosed, not a specific technologically limited implementation of an existing system concept.

The traditional CDMA cellular network architecture is designed to carry a wireless call between a wireless subscriber device and a base station, by simultaneously using multiple base stations or antennas to mitigate the effects of signal fading of various types, including, but not limited to: Rayleigh, rician and log-normal. If one cell or one antenna in the CDMA cellular network has a poor signal for a given time frame, another cell or antenna in the CDMA cellular network which had an acceptable signal carries the call. This call management process is called soft or softer hand-off, depending on whether the call is carried between two cells or two antennas at a given cell, respectively.

Cellular Communication Network Architecture

Figures 1A - 1C are the block diagram of the architecture of the communiqué system for private virtual narrowcasts 100 and one example of existing commercial cellular and wireline communication networks in which it is implemented. In the description of the communiqué system for private virtual narrowcasts, the major entities of the cellular communication network providing communiqué services to the wireless subscriber device 101 are the Base Station Subsystems 131-151 that are associated with the Mobile Telephone Switching Office 106. In a typical cellular communications network, there are numerous Mobile Telephone Switching Offices 106, but for the sake of simplicity only a single Mobile Telephone Switching Office is shown.

The typical implementation of an existing Mobile Telephone Switching Office 106 comprises a Mobile Telephone Switching Office Controller 106C which executes call processing associated with the Mobile Telephone Switching Office 106. A switching network 106N provides the telephone connectivity between Base Station Subsystems 131-151. Base Station Subsystems 131-151 communicate with wireless subscriber device 101 using Radio Frequency (RF) channels 111 and 112, respectively. RF channels 111 and 112 convey both command messages as well as digital data, which may represent voice signals being articulated at the wireless subscriber device 101 and the far-end party. With a CDMA system, the wireless subscriber device 101 communicates with at least One Base Station Subsystem 131. In Figure 1, the wireless subscriber device 101 is simultaneously communicating with two Base Station Subsystems 131, 141, thus constituting a soft handoff. However, a soft handoff is not limited to a maximum of two base stations. Standard EIA/TIA IS-95-B supports a soft handoff with as many as six base stations. When in a soft handoff, the base stations serving a given call must act in concert so that commands issued over RF channels 111 and 112 are consistent with each other. In order to accomplish this consistency, one of the serving Base Station Subsystems may operate as the primary Base Station Subsystem with respect to the other serving Base Station Subsystems. Of course, a wireless subscriber device 101 may communicate with only a single Base Station Subsystem if determined as sufficient by the cellular communication network.

Cellular communication networks provide a plurality of concurrently active communications in the same service area, with the number of concurrently active communication connections exceeding the number of available radio channels. This is accomplished by reusing the channels via the provision of multiple Base Station Subsystems 131-151 in the service area that is served by a single Mobile Telephone Switching Office 106. The overall service area of a Mobile Telephone Switching Office 106 is divided into a plurality of "cells", each of which includes a Base Station

Subsystem 131 and associated radio transmission tower 102. The radius of the cell is basically the distance from the base station radio transmission tower 102 to the furthest locus at which good reception between the wireless subscriber device 101 and the radio transmission tower 102 can be effected. The entire service area of a Mobile Telephone Switching Office 106 is therefore covered by a plurality of adjacent cells. There is an industry standard cell pattern in which sets of channels are reused. Within a particular cell, the surrounding cells are grouped in a circle around the first cell and the channels used in these surrounding cells differ from the channels used in the particular cell and from each of the other surrounding cells. Thus, the signals emanating from the radio transmission tower in the particular cell do not interfere with the signals emanating from the radio transmission towers located in each of the surrounding cells because they are at different radio frequencies and have different orthogonal coding. However, in the case of soft handoff, the frequencies must be the same for all cells involved in the soft or softer handoff process. In addition, the next closest cell using the transmission frequency of the particular cell is far enough away from this cell that there is a significant disparity in signal power and therefore sufficient signal rejection at the receivers to ensure that there is no signal interference. The shape of the cell is determined by the surrounding terrain and is typically not circular, but skewed by irregularities in the terrain, the effect of buildings and vegetation and other signal attenuators present in the cell area. Thus, the cell pattern is simply conceptual in nature and does not reflect the actual physical extent on the various cells, since the implemented cells are not hexagonal in configuration and do not have precisely delimited boundary edges.

The control channels that are available in this system are used to setup the communication connections between the subscriber stations 101 and the Base Station Subsystem 131. When a call is initiated, the control channel is used to communicate between the wireless subscriber device 101 involved in the call and the local serving Base Station Subsystem 131. The control messages locate and identify the wireless subscriber device 101, determine the dialed number, and identify an available voice/data communication channel consisting of a pair of radio frequencies and orthogonal coding which is selected by the Base Station Subsystem 131 for the communication connection. The radio unit in the wireless subscriber device 101 retunes the transmitter-receiver equipment contained therein to use these designated radio frequencies and orthogonal coding. Once the communication connection is established, the control messages are typically transmitted to adjust transmitter power and/or to change the transmission channel when required to handoff this wireless subscriber device 101 to an adjacent cell, when the subscriber moves from the present

cell to one of the adjoining cells. The transmitter power of the wireless subscriber device 101 is regulated since the magnitude of the signal received at the Base Station Subsystem 131 is a function of the subscriber station transmitter power and the distance from the Base Station Subsystem 131. Therefore, by scaling the transmitter power to correspond to the distance from the Base Station Subsystem 131, the received signal magnitude can be maintained within a predetermined range of values to ensure accurate signal reception without interfering with other transmissions in the cell.

The voice communications between wireless subscriber device 101 and other subscriber stations, such as land line based subscriber station 109, is effected by routing the communications received from the wireless subscriber device 101 via switching network 106N and trunks to the Public Switched Telephone Network (PSTN) 108 where the communications are routed to a Local Exchange Carrier 125 that serves land line based subscriber station 109. There are numerous Mobile Telephone Switching Offices 106 that are connected to the Public Switched Telephone Network (PSTN) 108 to thereby enable subscribers at both land line based subscriber stations and wireless subscriber devices to communicate between selected stations thereof. This architecture represents the present architecture of the wireless and wireline communication networks. The communiqué system for private virtual narrowcasts 100 is shown connected to the Public Switched Telephone Network 108, the Mobile Telephone Switching Offices 106, as well as a data communication network such as the Internet 107, although these examples of interconnections are subject to an implementation selected by the purveyor of communiqué services and some of these connections can be eliminated as unnecessary for some implementations as described below.

Format of the Forward CDMA Channel

Figure 3 illustrates in block diagram form a typical configuration of the Base Station Subsystem 131 to wireless subscriber device 101 forward CDMA channel used in cellular communication networks. The typical Base Station Subsystem 131 to wireless subscriber device 101 forward CDMA channel comprises a predefined bandwidth centered about a selected carrier frequency. The bandwidth of the selected channel as well as the selected carrier frequency is a function of the technical implementation of the Base Station Subsystem 131 of the cellular communication network and is not discussed further herein. The channel is typically divided into a plurality of segments: Pilot 301, Synchronization (Synch) 302, Paging 303, Traffic 304. The Paging 303 and Traffic 304 segments are further divided into a plurality of channels Ch1-Ch7 and Ch1-Ch55, respectively. Each traffic channel represents a

communication space for a selected wireless subscriber device 101. The plurality of paging channels Ch1-Ch7 are available for the Base Station Subsystem 131 to page a selected wireless subscriber device 101 in well-known fashion. In order to segregate these channels, each channel is assigned a selected one of the 64 Walsh codes, from
5 W=0 to W=63. For example, the Pilot channel is assigned a Walsh code of W=0, while the Synch channel is assigned a Walsh code of W=32. The Paging channels Ch1-Ch7 are assigned Walsh codes of W=1-W=7, respectively. The remaining Walsh codes are assigned to the traffic channels CH1-CH55 as shown in Figure 3. Each Traffic channel consists of data traffic 311 as well as in band signaling 312 transmitted from the Base
10 Station Subsystem 131 to the wireless subscriber device 101.

Idle Handoff of Wireless Subscriber Devices

Figure 2 illustrates in flow diagram form the operation of a typical cellular communication system in implementing an idle handoff mode of operation. An idle handoff occurs when a wireless subscriber device 101 has moved from the coverage
15 area of one Base Station Subsystem 131 into the coverage area of another Base Station Subsystem 141 during the Wireless Station Idle State. As shown in Figure 2, at step 201, the wireless subscriber device 101 scans for pilot signals for the base stations that serve the coverage area in which the wireless subscriber device 101 is operational. If the wireless subscriber device 101 detects a Pilot channel signal from
20 another base station subsystem 141, that is sufficiently stronger than that of the present Base Station Subsystem 131, the wireless subscriber device 101 determines that an idle handoff should occur. Pilot channels are identified by their offsets relative to the zero offset pilot PN sequence and typically are the Walsh Code 0 for each channel. The wireless subscriber device 101 at step 202 groups pilot offsets into sets describing
25 their status with regard to pilot searching. The following sets of pilot offsets are defined for a wireless subscriber device 101 in the Wireless Station Idle State. Each pilot offset is a member of only one set.

Active Set: The pilot offset of the Forward CDMA Channel whose Paging channel is being monitored.

30 Neighbor Set: The offsets of the Pilot channels that are likely candidates for idle handoff. The members of the Neighbor Set are specified in the Neighbor List Message, Extended Neighbor List Message, and the General Neighbor List Message.

Remaining Set: The set of all possible pilot offsets.

35 In the process of Figure 2, the wireless subscriber device 101 at step 203 selects the 3 strongest pilot signals for use in establishing/maintaining the cellular communication connection. In this process, the RAKE receiver in the wireless subscriber device 101 at step 207 continuously looks for the strongest pilot signals to

ensure the continuation of the cellular communication connection. The wireless subscriber device 101 at step 204 decodes the pilot signals and locks on to the synch channel of selected forward CDMA channels having the strongest pilot signals.

At step 205, the wireless subscriber device 101 switches to selected Traffic channels, one per selected forward CDMA channel and demodulates the signals received therein and at step 206 outputs the demodulated multi-media output to the user interface of the wireless subscriber device 101 for use by the subscriber.

As described herein, the overhead required in point to point cellular communications to manage hand-offs between cells within the cellular communication network is considerable and continuous, since many of the wireless subscriber devices served by the cellular communication network are mobile in nature. In the communiqué system for private virtual narrowcasts, the need for this overhead in processing call hand-offs is reduced since the wireless subscriber device is not provided with a unique communication link, but shares this link with many other wireless subscriber devices. There are a number of communiqué implementations that can be overlaid on this standard handoff process.

Wireline Communication Network Architecture

Figure 1C illustrates in block diagram form the overall architecture of a typical wireline-based communication network in which the communiqué system for private virtual narrowcasts 100 is operational. For the purpose of illustrating the communiqué concepts, a broadband cable television network 170 is described, which functions to distribute the communiqués received from the communiqué system for private virtual narrowcasts 100 to selected ones of a plurality of wired subscriber devices 172-174 that are served by the broadband cable television network 170. The following description only provides the high level concepts of the broadband cable television network 170 to simplify the description, since the implementation details of this system are well-known and not pertinent to the implementation of the communiqué service. There are numerous type of wired subscriber devices and those described herein are selected to simply illustrate the operation of the system. There are also other types of wireline-based communication networks that can support the communiqué system for private virtual narrowcasts 100, such as traditional telephone systems, Local Area Networks, and the like. The wireline-based communication networks can use a variety of physical media to interconnect the communiqué wired subscriber devices to the wireline-based

communication network and these include: twisted pair, Ethernet, coaxial cable, fiber optic cable, DSL on twisted pair, 4-wire, and the like.

Existing broadband cable television networks 170 comprise a multi-layer network which are used to distribute program materials, such as video, from program sources that are connected to a head end 171, through the various layers of the multi-layer network to the end user locations. A typical multi-layer network comprises a multiplicity of layers (typically two) interposed between the head-end 171 and the distribution nodes 191-192 that serve a plurality of end user locations. The original broadband cable television networks were engineered to provide a one-way distribution of video program material to the end user locations, therefore 95% of the available data transmission bandwidth in these broadband cable television networks are dedicated to transmissions from the head-end to the end user locations. The upstream path of the broadband cable television network is therefore a critical resource that limits the number of end user locations that can be served by a distribution node and also limits the number and nature of new interactive services that can be offered to the end user locations. Therefore, existing service offerings are limited to those that place a minimal demand on the upstream communication capabilities of the broadband cable television network. In addition, service providers have limited the number of end user locations that can be served by each passive fiber node in the broadband cable television network to enable the upstream channel to serve these end user locations. Therefore, the bandwidth limitation of the upstream channel in the broadband cable television network represents a service offering limitation and an inefficiency in terms of the number of end user locations that can be served.

Figure 1C illustrates in block diagram form the architecture of a typical broadband cable television network. In this network, the various end user locations are typically served by distribution nodes 191-192 which serve to interconnect a plurality of end user locations and their associated wired subscriber devices to ones of secondary hubs 181-185. A plurality of secondary hubs 181-185 are in turn interconnected to and served by primary hubs 175-176, a plurality of which are connected to a head-end 171. The head-end 171 receives data from various sources, and a few typical content sources are shown here. In particular, the head-end 171 is connected to a plurality of content sources. The sources can be a remotely located program source for providing for example network news, such as a national network station 122A that is connected

via a satellite uplink 123A and satellite 124A to a satellite downlink 126A and forwarded to satellite interface 117A that is part of the head-end 171 or can use the Public Switched Telephone Network and trunk interface 116D. Alternatively, the program source can be a local program source 120A for local news and information, that is
5 connected via a data communication medium, such as the Internet 107A, to an Internet server interface 115A of the head-end 171. The various program sources provide information of various types, including but not limited to: news, advertisements, traffic, weather, travel information, and the like. Thus, data transmitted to the head-end 171 is forwarded through the primary hubs 175-176 and the secondary hubs 181-185 to the
10 distribution nodes 191-192 and the local loops to the wired subscriber devices at the end user locations.

The communiqué system for private virtual narrowcasts 100 also provides a data input to the head-end 171. This input is the program stream described below and is distributed to the end user locations where the communiqués are presented to the
15 subscribers via the wired subscriber devices. The communiqué wireless subscriber device MS described below provides addressing, registration and authentication functions that are directly applicable to a typical wired subscriber device. For example, the wired subscriber device can be a set top box that serves a television set and is equipped to provide both upstream and downstream communications as noted above.
20 Thus, the cable television network set top box registration can be effected in a manner that is analogous to cellular communication network registration process used for the communiqué wireless subscriber device MS, with the communication channels used for communiqués in the broadband cable television network 170 being the television channels.

25 **Philosophy of the Communiqué System**

The terms "cell site" and "cell" are sometimes loosely used in the literature, and the term "cell site" generally denotes the locus, such as Base Station Subsystem 131, at which the radio frequency transmitter and receiver apparatus (Base Station Transceiver 133, 143, 144, 153) is located, while the term "cell" generally denotes the
30 region of space which is served by a particular radio frequency transmitter-receiver pair which is installed in Base Station Transceiver 133 at Base Station Subsystem 131, and includes sectors of a particular cell where the cell comprises a plurality of sectors. The cells can also be the coverage area that is created by in-building wireless communication systems, private wireless networks, as well as wireline-based
35 communication networks. The collection of wired subscriber devices served by a

wireline communication network or a segment thereof is considered a cell for the purposes of this description.

The particular technology used to implement the communications between wireless subscriber devices and the radio frequency transmitter-receiver pairs and
5 between the head-end and the wired subscriber devices as well as the nature of the data transferred there between, be it voice, video, telemetry, computer data, and the like, are not limitations to the communiqué system for private virtual narrowcasts 100 which is described herein, since a novel system concept is disclosed, not a specific technologically limited implementation of an existing system concept. Therefore, the
10 term "cellular" as it is used herein denotes a communication system which operates on the basis of dividing space into a plurality of volumetric sections or cells, and managing communications between wireless subscriber devices located in the cells and the associated radio frequency transmitter-receiver pairs located at the cell site for each of these cells. In addition, the term "telecommunications cell" is used in the general sense
15 and includes a traditional cell generated by a cell site as well as a sector of a cell, as well as a cell elevation sector, regardless of size and shape.

The wireless subscriber device, as noted above, can be any of a number of full function communication devices that include: standard cellular telephones, WAP enabled cellular telephones, personal digital assistants, Palm Pilots, personal
20 computers, and the like or special communiqué only communication devices that are specific to communiqué reception; or MP3 audio players (essentially a radio receiver or communiqué radio); or an MPEG4 video receiver (communiqué TV); or other such specialized communication device. The subscriber terminal devices can either be mobile wireless communication devices in the traditional mobile subscriber paradigm,
25 or the fixed wireless communication devices in the more recent wireless product offerings.

The communiqué system for private virtual narrowcasts operates with existing cellular communication networks, as described above, to provide other than strictly point to point communication services, which are collectively termed "communiqué services"
30 herein, to subscribers. The Communiqué transported by this system can be unidirectional (broadcast) or bi-directional (interactive) in nature and the extent of the Communiqué can be network-wide or narrowcast, where one or more cells and/or cell sectors are grouped to cover a predetermined geographic area or demographic population or subscriber interest group to transmit information to subscribers who
35 populate the target audience for the narrowcast transmissions. For instance, the coverage region can be implemented in the radio frequency domain by using frequency assignments, code assignments or dynamically shaped antenna patterns. Pattern

shaping is done now to manage capacity constraint issues (e.g. a cell size would be shaped/shrunk at busy hour with adjacent cells helping to carry a particular region's traffic). The communiqué system for private virtual narrowcasts can use pattern shaping to create a narrowcast region for instance. In addition, the applications can include asymmetric bi-directional communications where private virtual narrowcasts are the stimulus for point-to-point responses from subscriber terminal devices.

The communiqué system for private virtual narrowcasts 100 creates broadcast and/or narrowcast regions in a "virtual" manner. With this concept, the RF configuration is separable, in that it can be static in its architecture or it could be configured as described above in a dynamic manner. The "virtual" architecture is achieved in the content domain - a very powerful and flexible concept. By selectively enabling and disabling specific content on a cell-by-cell basis, a shaped broadcast or narrowcast can be realized from the end-subscriber's perspective even though the RF configuration may have remained static or unchanged. This is a powerful narrowcast tool since it is relatively simple to dynamically change the specific content being transmitted at a given cell. The combinatorial effect is spatial and temporal in its extent even though the RF architecture may have been unchanged.

The preferred method for creating a virtual private narrowcast is to, in the time domain, establish a packet framing protocol wherein each virtual private narrowcast group accesses only the time slots within the packet frame that are intended for it. In this example, the RF carrier is operating at a particular frequency and, if the transmission protocol is CDMA, a particular Walsh code is also incorporated. The composite data stream is then segmented in the time domain on a dynamic and adaptive basis using a variety of factors: the number of virtual private narrowcasts, the number of subscribers receiving a given virtual private narrowcast, the time-sensitive importance of the data for a given virtual private narrowcast, general network loading to include circuit switched traffic loads, the time-based rate of change of end-subscribers entering/exiting a given virtual private narrowcast region (or cell, or sector), and so on. A narrowcast directory can be used to provide the end-subscribers with information on where to "look" for content/data which is specific for a given virtual private narrowcast. Security and subscription levels manage which end-subscribers have access to which virtual private narrowcast data streams.

Operationally, the network, upon recognizing and tallying the number of end-subscribers of a particular virtual private narrowcast that are located within a given cell or cell sector, can add or delete a new time slot within the virtual private narrowcast

packet frame for the new cluster of end-subscribers who recently entered or departed the cell or cell sector coverage region. In addition, the network can modify a particular virtual private narrowcast group's time slot size based on the number of subscribers and the overall level of traffic to be conveyed, whether it be unidirectional or bi-directional.

5 In essence, the virtual private narrowcast architecture enables multiple simultaneous narrowcast communiqués with each virtual private narrowcast having differing coverage areas and effective bandwidths based on the number of virtual private narrowcast subscribers in a given location or based on the type of traffic they need to convey. Again, the key concept is creation of dynamic virtual private narrowcast regions through
10 the use of how the content domain is managed (i.e. what content is delivered to which cells). By delivering the same virtual private narrowcast slots to multiple locations, a content domain coverage region is created. This architecture offers incredible flexibility in terms of its ability to offer real-time services to multiple subscribers formed into pre-determined demographic groups. The true power of this approach is that each virtual
15 private narrowcast can have its own coverage area and, more important, the coverage area or areas may be noncontiguous. Conceptually, the delivery costs for these types of services are de minimis since millions of subscribers formed into thousands of virtual private narrowcasts all share a minute fraction of the overall delivery cost.

The basic functionality of the communiqué system for private virtual narrowcasts
20 100 comprises an information distribution management functionality that concurrently propagates information to a plurality of wireless subscriber devices, using push, pull and combinations of push/pull data propagation modes. The need for information dissemination is identified: in response to external events, in response to predetermined temporal/spatial stimuli; as a function of subscriber inquiries/requests; and the like. The
25 communiqué system for private virtual narrowcasts 100, in response to an identified information dissemination event, identifies a plurality of cells in the cellular communication network as well as available communication channels in each of these cells to carry the information that is to be transmitted to a plurality of wireless subscriber devices extant in the locales served by the selected cells, as well as communication
30 channels and sites served by the wireline communication network. The communication channels can be dedicated to communiqué services or can be selected from the pool of available communication channels. The subscribers access the Communiqués by selecting the communication channel on their wireless subscriber device or wireline

subscriber device that carries the Communiqué. The subscriber can be alerted to the presence of the Communiqué in many ways or can activate their wireless subscriber device or wireline subscriber device to retrieve the Communiqué absent any alert being transmitted to the wireless subscriber device or wireline subscriber device. The

5 Communiqué retrieved by the subscriber is not subscriber-unique, in that the Communiqué is transmitted to many subscribers, with a plurality of subscribers concurrently accessing the Communiqué being a typical mode of operation. In addition, the bandwidth required for communiqué services can be variable, with unused channels of the existing cellular communication network being allocated on an as needed basis

10 to communiqué services. Furthermore, the routine point to point cellular communication traffic can be load balanced with the communiqué services, with routine cellular traffic being preferentially served by cells that have unused capacity to thereby free up channels in other cells for communiqué services. In addition, the communiqué system for private virtual narrowcasts 100 identifies the appropriate source of information

15 available from a program source that is to be used to constitute the communiqué service. The information can be a predetermined continuous feed, or can be comprised of a plurality of segments that can be interspersed with advertisements, other information segments and the like.

Communiqué Wireless Subscriber Devices

20 Communiqué wireless subscriber devices MS are end-user devices (such as wireless subscriber devices 101) that are capable of receiving narrowcasted content from broadband cellular networks that deploy next generation architectures such as WCDMA (Wideband Code Division Multiple Access), CDMA2000, HDR (High Data Rate) and so on. This narrowcasted content (communiqué) is multimedia in nature and

25 simultaneously delivered to multiple communiqué wireless subscriber devices. The narrowcasted content includes:

- audio (music, radio shows, news and the like),
- video (MTV-like videos, news, live traffic cams and the like), and
- data (text information, stock quotes, graphical information and the like).

30 The end-user devices, herein now called communiqué wireless subscriber devices MS, are in many cases, next generation radio-television-internet receivers for generally unidirectional receipt of transmissions that have a highly targeted demographic focus. The above-noted content are conveyed by Radio Frequency

transmissions with the preferred delivery means being next generation, or third generation (3G), wireless cellular systems in a one-to more than one broadcast or narrowcast mode of operation. The demographic groups used for narrowcasting can range in size from a small neighborhood to a sports stadium as determined by the granularity of the cellular architecture being re-used to deliver the narrowcasted content. The content delivery region and conveyed content are dynamically changeable depending on the associated demographics.

Communicé wireless subscriber devices are multi-media devices and, as such, output digital content to the end-user in the following forms:

- 10 Digital Audio
- Digital Video
- Digital Internet
- Digital Text
- 15 Digital Graphics

The architecture of a communiqué wireless subscriber device is derived from modifications to existing and planned cellular radio architectures. The implementation of Narrowcast/Communicé capability is largely performed in software/firmware with the wireless radio frequency communication interface remaining very similar to present and future standards. In essence, the architecture is a novel systems overlay leveraging what already exists.

The present wireless architecture paradigm of circuit switched calls with the connection being exclusively between two single network nodes is obsolete in the narrowcasting mode of operation. Narrowcasting enables a cellular architecture to convey information or content to multiple communiqué wireless subscriber devices at the same time. In order to do this, two general systems problems must first be resolved:

- Multiple communiqué wireless subscriber device Addressing
- Handoffs in a Unidirectional Narrowcast.

These issues are discussed below.

30 Figure 9 illustrates, in block diagram form, the architecture of a typical embodiment of the communiqué wireless subscriber device MS of the present invention. This particular embodiment of the communiqué wireless subscriber device MS is disclosed to illustrate the concepts of the invention and is not intended to limit the

application of the disclosed concepts. The communiqué wireless subscriber device MS is equipped with a processor CONTROL that operates pursuant to instructions that are stored in MEMORY and the subscriber profile information stored in profile memory PS, as is described below. In this particular application, the communiqué wireless subscriber device MS can also contain mobile unit location apparatus, such as global positioning system GPS, to produce an indication of the location of the communiqué wireless subscriber device MS.

The communiqué wireless subscriber device MS is equipped with transmitter TRANS and receiver RCV circuits well known in cellular communications for providing voice and data communications via a voice data switch VDS. The apparatus also includes antenna VPA, which is typically mounted on an exterior surface of the communiqué wireless subscriber device MS and coupled in well known fashion to the transmitter TRANS and receiver RCV circuits by a duplexor. The power output of the transmitter TRANS can also be dynamically regulated as a function of the distance from the cell site transmitter antenna to ensure a relatively constant signal level, using the Power Control circuit presently available in many cellular radio systems.

The communiqué wireless subscriber device MS includes a user interface NTR that is equipped with the apparatus necessary to enable the user to receive and input data. For example, the user interface NTR includes a display device VD that produces a human sensible visualization of the data that is received and audio output device LS to produce a human sensible audio output of the received data. The user interface can also include audio input devices MIC and keyboard K (and/or mouse or pointer device) to enable the user to input data in an audible or textual form, respectively. The user interface NTR can optionally include a biometric interface BM that measures an immutable physical characteristic of the user, such as a fingerprint, retina scan, and the like, to enable the communiqué wireless subscriber device MS to authenticate the identity of the user. In addition, the communiqué wireless subscriber device MS can include sensors, or an interface SENI that is adapted to connect to one or more sensors SM1, SM2, to measure selected parameters, such as ambient temperature, velocity, altitude, and the like.

In the case of a receive-only communiqué wireless subscriber device, it is evident that the implementation described above can be simplified, since the transmitter

TRANS is not needed and many of the other capabilities, such a Global Positioning System and the like are likely not required.

Dynamically Configured Wireless Local Area Networks

There is presently an effort to manufacture wireless subscriber devices that are interoperable, via short-range, low power communications. These wireless subscriber devices are formed into a small wireless network on an ad hoc basis. Each wireless subscriber device seeks out and configures itself with a resident server device, which can be a permanent access point that is interconnected for example with the communiqué system for private virtual narrowcasts 100 or another wireless subscriber device.

An example of such a philosophy is presently embodied in the Bluetooth Special Interest Group which uses a wireless paradigm for interoperability of devices using a carrier frequency of between 2,400 MHz and 2,483.5 MHz to support a plurality of data transfer channels, which are either asymmetric or symmetric, as a function of the application that is enabled. The communiqué wireless subscriber device MS therefore can include a dynamic network system DNS that includes a local radio frequency (RF) transceiver LT, a baseband link control unit BU, associated link management control software/hardware LM and an antenna system PA. The transmitter portion of the local radio frequency transceiver LT mixes the baseband information with the frequency hopping local oscillator to generate a frequency-modulated carrier. The receiver portion of the local radio frequency transceiver LT down converts and demodulates the RF signal using the same oscillator in the adjacent time slot. The local radio frequency transceiver LT supports both point-to-point and point-to-multi-point connections. A plurality of wireless subscriber devices so enabled can dynamically configure themselves into a "piconet", with one wireless subscriber device designated as the master and the remaining units as slaves, or a peer-to-peer configuration. The piconet is distinguished from other similar piconets in the vicinity by the frequency hopping sequence. The baseband protocol can be used for both circuit and packet switched transmissions. Synchronous links can be established for voice connections, using reserved time slots, while asynchronous links are dedicated for data transmissions.

For example, the dynamic network system DNS may be used to serve a single auxiliary handset unit H and/or terminal device HT and can optionally be multiplexed to serve a plurality of auxiliary handset units H, H' and/or terminal devices HT, HT'. The

auxiliary handset H and/or terminal device HT can be hard wired to the communiqué wireless subscriber device MS or can be a wireless unit H', HT' of limited communication range that interconnects with the communiqué wireless subscriber device MS via radio frequency transmissions as noted above. In the multi-user application, the communiqué wireless subscriber device MS can comprise a "mini-cell" wherein the various auxiliary handsets H, H' and/or terminal devices HT, HT' are managed by the communiqué wireless subscriber device MS in a manner analogous to that performed by the typical cell site/MTSO. Thus, the handset units H, H' and/or terminal devices HT, HT' can be of a different technology, with the communiqué wireless subscriber device MS performing an integration function as well as the multiplexing function. The handsets H, H' can be personal communication system (PCS) units, pagers, code division multiple access (CDMA) units, or any other wireless communication devices which are in use by individuals. The communiqué wireless subscriber device MS receives the signals generated by the various handset units and formats (if necessary) the data contained in these transmissions into the format used for the radio link transmissions to the cell site. The communications in the reverse direction are managed in a complementary manner as is well known. The handset units H, H' can each have a unique identification which enables the underlying cellular communication network to communicate with the unit. The communiqué wireless subscriber device MS can therefore perform the handset registration function by polling the handset units extant in the space served by the electronics unit to thereby identify these units. This unit identification data can then be transmitted to the cell site via the control channels to enable the cellular network to ascertain the location of these particular units.

25 **Communiqué Wireless Subscriber Device - CDMA System Features**

In addition to the above-noted characteristics of the communiqué wireless subscriber device MS, there is an alternative cellular communication system termed Code Division Multiple Access (CDMA) which transmits a plurality of communications on each channel and differentiates the various communiqué wireless subscriber devices MS by the code assigned to each communiqué wireless subscriber device MS. These CDMA systems transmit multiple conversations on the same frequency. In order to maintain the overall system noise level at a minimum, the power level of the various communiqué wireless subscriber devices MS must be precisely controlled. With a

typical CDMA system, 64 Walsh codes are used to differentiate among the wireless subscriber devices served by a cell site and a predetermined number of these codes can be reserved for the exclusive use by communiqué wireless subscriber devices MS, since generally all of these codes are not all are used in a typical ground-based cell site.

5 Thus, the code separation in a CDMA system can be used to prevent the interference between communiqué wireless subscriber devices MS and the conventional ground-based wireless subscriber devices and their cell sites. In conjunction with unique Walsh code assignments, the network can also assign unique "Wide Area" code words to identify a virtual network overlay.

10 The data communication capability of the communiqué wireless subscriber device MS can be enhanced by increasing the bandwidth of the communication connection that is established with the cell site. There are a number of ways to provide an increased bandwidth, including allocating multiple communication channels to the data communication function. Thus, a single call connection for data communication
15 purposes comprises multiple physical communication channels managed in parallel to thereby multiply the data communication capacity associated with a single channel in the system. Alternatively, dedicated data communication channels can be allocated in the defined communication space, with the data communication channels occupying the bandwidth of multiple voice communication channels. In either case, the data
20 communication capability of the communiqué wireless subscriber device MS can be adapted to suit the needs of the subscriber.

An example of this is the connection of another terminal device, such as personal computer HT equipped with a modem, to the communiqué wireless subscriber device MS to thereby enable the user to transmit and receive data over the cellular voice
25 communication connection, as is well known. The data can include facsimile transmissions, E-Mail, data files and the like. Additionally, the terminal device HT can include a video display and the data displayed thereon can be entertainment or informational programs that are uploaded from the cell site or a source connected to the communiqué wireless subscriber device MS via a cellular communication connection.

30 **Communiqué Services in Cellular Communication Networks**

As can be seen from the above description, the transceiver GBR of the communiqué wireless subscriber device MS listens for the strongest pilot signal in one of the available communication channels and uses this pilot signal to derive a

time/frequency reference. The communiqué wireless subscriber device MS then demodulates the synch signal for this communication channel to precisely align the clock of the communiqué wireless subscriber device MS with that contained in the Base Station Subsystem 131. For a broadcast mode of operation, the communiqué wireless subscriber device MS must be given information that identifies which PN codes are broadcast/narrowcast signals for this communication channel. This can be accomplished by transmitting directory information to the communiqué wireless subscriber device MS in the pilot or synch signals or by using a predefined PN code for selected broadcast signals.

Since the cellular communication network continuously transmits the Communiqué signals from various cell sites, there is no statistical reduction of self-interference. Therefore, proper selection of frequencies for transmission and PN codes is necessary to reduce interference. Each PN code space can contain either a single transmission or can be used in a multiplex mode where multiple signals are transmitted.

In the latter mode, time slotted baseband data is streamed on a single CDMA waveform by the creation of multiple subchannels in each frame of the transmission. In this manner, lower data rate signals can share a single transmission.

The Mobile Telephone Switching Office 106, in conjunction with the VLR and HLR, helps to manage the registration process that includes subscriber authorization.

The Visitor Location Register 161 and the Home Location Register 162 are essentially sophisticated databases that are hooked to the Mobile Telephone Switching Office 106.

The VLR and HLR are sometimes the same device with logical functional partitions although VLRs can stand alone and can be distributed in their deployment while HLRs are typically more centralized. The Communiqué Location Register (CLR) 163, is the apparatus in the communiqué system for private virtual narrowcasts 100 where all of the systems information for subscribers' authorization and service plans reside. This has substantial merit in terms of practical implementation since it can be a wholly separate device that connects to the Mobile Telephone Switching Office 106 or as an integral part of the communiqué system for private virtual narrowcasts 100. The Communiqué Location Register 163 is attached to the Mobile Telephone Switching Office 106 in a manner similar to the HLR/VLR.

In order to describe the various services that are available from the communiqué system for private virtual narrowcasts 100, the terms used to describe the processes

operational in the recognition of a subscriber and provision of service to a subscriber must be defined. "Acquisition" is the process where the communiqué wireless subscriber device MS scans for pilots, locks onto synch channels and has all system based knowledge necessary to know where and how to receive Communiqués.

5 "Registration" is the process that entails the interchange of information between the communiqué wireless subscriber device MS and the cellular communication network wherein the cellular communication network becomes aware of and knows which subscribers are receiving Communiqués and where they are receiving them.

"Authorization" is the process where the communiqué system for private virtual
10 narrowcasts 100 grants end-user access to broadcast or narrowcast content to one or many subscribers in a general or specific location. Thus, a "free" communiqué service has the ACQUISITION process but does not have REGISTRATION or AUTHORIZATION processes. "Subscription" communiqué services have all three processes. "Pre-pay" communiqué services have a modified ACQUISITION process
15 but do not include REGISTRATION or AUTHORIZATION processes. Therefore, the term "autonomous" can be used to describe the "free" broadcast architecture, since the cellular communication network does not know who is listening or where they are listening. This is the equivalent of today's broadcast radio and TV with the exception that the content can be specialized into "free" narrowcasts that have a limited spatial
20 extent which can be dynamically managed. The communiqué wireless subscriber device MS used for such a communiqué service can be a one-way receive only (ultra-low cost) communiqué wireless subscriber device MS. For a communiqué service that includes free broadcasts and subscription services, the communiqué wireless subscriber device MS is not content interactive, meaning communiqué services such
25 as request-reply are not available. The communiqué wireless subscriber device MS is two-way in terms of its communication capability with the network for registration and authorization purposes. A Pre-pay Subscription communiqué service is conceptually similar to the digital TV recorders that have a one-time-only pre-pay subscription fee. This concept uses a modified forward paging channel to provide initialization
30 information for traffic channels and then uses in-band signaling on the forward traffic channel to convey systems information.

Addressing of Communiqué Wireless Subscriber Devices

First, a method is needed to “spoof” or fool the existing cellular communication system into sending content to more than one user at a time. Or, in other words, what is needed is an addressing scheme that is consistent with present and future practice but transcends the traditional circuit switched one-to-one architecture. Multiple methods of communiqué wireless subscriber device addressing are possible but one approach stands out as being least invasive in terms of architecture modification. While this method is the preferred approach, it is by no means the only method.

The preferred embodiment is through the creation of a common MIN or Mobile Identification Number. This universal MIN is deployed ubiquitously across all communiqué wireless subscriber devices. The universal narrowcast MIN enables all communiqué wireless subscriber devices to receive all content wirelessly conveyed to the communiqué wireless subscriber device. This universal MIN is stored in profile memory PS of the communiqué wireless subscriber device MS to thereby enable this device to access the services to which it is authorized. In addition, the universal MIN can be used as a filter, where the communiqué wireless subscriber device MS receives the content, but this does not necessarily mean the end-user has access to it. The universal MIN acts as a portal key merely enabling the narrowcasted content to pass through, as regulated by the subscriber profile information and subscription authorizations stored in profile memory PS and executed by the processor CONTROL.

The universal MIN does not determine whether the end-user has usable access to the narrowcasted content. Content access is determined through other means to include a hierarchical subscription type of model. A hierarchical content subscription service ranges from free to subscription access to pay-per-receipt (pay-per-listen, pay-per-view). Only specific types of communiqué wireless subscriber devices are capable of hierarchical content subscriptions since this requires a means for authorized access.

One method involves a pre-paid form of lifetime subscription (which doesn't require a bi-directional communiqué wireless subscriber device); another is a method for the communiqué wireless subscriber device to interact with the networks billing/authorization systems to enable end-user access to specific types of services (this is a bi-directional communiqué wireless subscriber device).

Handoff of Communiqué Wireless Subscriber Devices

Second, a method is needed to enable a one-way communiqué wireless subscriber device to coordinate its activities as required with the network. In particular, a method to enable handoffs is necessary to provide for seamless coverage. Handoffs
5 can take the following forms:

Soft (communiqué wireless subscriber device receives from multiple cells simultaneously on the same frequency but different Walsh codes)

Softer (communiqué wireless subscriber device receives from multiple sectors of a given cell on the same frequency but different Walsh codes)

10 Hard (communiqué wireless subscriber device receives from only one cell at a time on a given frequency and then switches frequencies as the handoff occurs to a new cell)

Digital CDMA architectures use all three types of handoffs while Analog FDMA and Digital TDMA are only capable of hard handoffs. From an architecture perspective
15 then, by solving the handoff problem for CDMA, the general handoff problem is solved for Analog and TDMA since the methods and concepts to perform a hard handoff on a CDMA platform are similar to what is done in Analog and TDMA architectures.

Types of Communiqué Wireless Subscriber Devices

When evaluating the two predominant issues, addressing and handoffs, they
20 must be considered in the context of the types of communiqué wireless subscriber devices that are possible, as noted in the following list.

1. One Way Narrowcast Reception, Incapable of Bi-Directional Administrative Systems Overhead ("Receive Only").
2. One Way Narrowcast Reception, Capable of Bi-Directional Administrative
25 Systems Overhead ("Receive Only, Two-way Admin Overhead").
3. Two Way Narrowcast Reception/Transmission, Capable of Bi-Directional Administrative Systems Overhead ("Transmit/Receive, Two-way Admin Overhead").

While the narrowcast architecture is predominantly one-way from the source to the communiqué wireless subscriber devices, bi-directional communiqués are also
30 possible. The last type of communiqué wireless subscriber device listed above has this capability.

Each communiqué wireless subscriber device type has a different type of network Registration—the process under which it becomes "connected" to the network.

This is different from the Authorization process described previously which enabled access to a particular type of content or narrowcast service. As previously described, the processes herein are for a CDMA architecture which is more complex in terms of its management of communiqué wireless subscriber devices particularly for the types of hand-offs required. The registration processes for an analog or TDMA or hybrid type of architecture are similar in concept and while the other methods are not described in detail here, the conceptual extension to the other architectures (analog/TDMA/hybrid) are well understood by those in the industry.

Unidirectional Transmission Without Subscriber Registration

There are numerous possible architectures that can be used to transmit information to the wireless subscriber devices with the architecture selected having an impact on the types of transmissions.

Figure 4 illustrates in block diagram form a typical assignment of cells in a cellular communication network for a unidirectional transmission without subscriber registration mode of operation of the communiqué system for private virtual narrowcasts 100, where a plurality of cells are transmitting Communiqué signals, with each cell using the same frequency and the same Walsh (PN) code for a selected Communiqué. There is a K=3 cell repeat pattern, although alternatively, the cells can be subdivided into three sectors for the same effect. In this manner, the communiqué wireless subscriber device MS does not have to search for the desired Communiqué, since the location is uniform throughout the cellular communication network. The communiqué wireless subscriber device MS is always in soft handoff mode and in the example of Figure 4, the PN code varies by cell according to the K=3 repeat pattern, so the communiqué wireless subscriber device MS maintains a soft handoff mode with the three PN codes, regardless of the location of the communiqué wireless subscriber device MS in the cellular communication network. Existing wireless subscriber devices are equipped with three receivers in the rake receiver system that enables operation in this mode.

Alternatively, adjacent cells (or cell sectors) can transmit the Communiqué signals on different frequencies, but this requires additional complexity in the wireless subscriber device, since the handoff must occur with both frequency and PN code making it a hard handoff. In addition, the lack of uniformity in the transmission frequency requires the wireless subscriber device to receive information from the base

station to identify the location of the desired Communiqué in order to enable the wireless subscriber device to lock on to the appropriate combination of frequency and PN code for each cell. One way of avoiding the complexity is illustrated in Figure 6 where there is a grouping of $K=3$ for the cells and the Walsh code assignment is static, using a specific Walsh code for each of the $K=3$ cells, such as Traffic channel 8 (Walsh code $W=8$) for the cell $K=1$ and Traffic channel Ch9 (Walsh code $W=9$) for the cell $K=2$ and Traffic channel Ch10 (Walsh code $W=10$) for cell $K=3$. Therefore, the subscriber does not need additional information from the cellular communication network to receive the broadcast information, since the communiqué wireless subscriber device MS has 3 RAKE receivers, which can each be locked on to one of the three Walsh codes $W=8$ - $W=10$ used in the $K=3$ repeat scenario. The communiqué wireless subscriber device MS can always be in a soft handoff mode to ensure that continual reception of the transmission takes place as the communiqué wireless subscriber device MS receives signals from the three predetermined Traffic channels.

For the "Receive Only" type of communiqué wireless subscriber device, the following Figure 2 describes the preferred registration algorithm although others are certainly possible (IS95 architecture adaptation). This is described as an Autonomous Registration since the network is unaware of the communiqué wireless subscriber device activity and the communiqué wireless subscriber device is incapable of communicating with the network.

Figure 2 illustrates in flow diagram form the operation of a typical cellular communication system in implementing an idle handoff mode of operation. An idle handoff occurs when a communiqué wireless subscriber device MS has moved from the coverage area of one Base Station Subsystem 131 into the coverage area of another Base Station Subsystem 141 during the Wireless Station Idle State. As shown in Figure 2, at step 201, the communiqué wireless subscriber device MS scans for pilot signals for the base stations that serve the coverage area in which the communiqué wireless subscriber device MS is operational. If the communiqué wireless subscriber device MS detects a Pilot channel signal from another Base Station Subsystem 141, that is sufficiently stronger than that of the present Base Station Subsystem 131, the communiqué wireless subscriber device MS determines that an idle handoff should occur. Pilot channels are identified by their offsets relative to the zero offset pilot PN sequence and typically are the Walsh Code 0 for each channel. The communiqué wireless subscriber device MS at step 202 groups pilot offsets into sets describing their status with regard to pilot searching. The following sets of pilot offsets are defined for

a communiqué wireless subscriber device MS in the Wireless Station Idle State. Each pilot offset is a member of only one set.

Active Set: The pilot offset of the Forward CDMA Channel whose Paging channel is being monitored.

5 Neighbor Set: The offsets of the Pilot channels that are likely candidates for idle handoff. The members of the Neighbor Set are specified in the Neighbor List Message, Extended Neighbor List Message, and the General Neighbor List Message.

Remaining Set: The set of all possible pilot offsets.

10 In the process of Figure 2, the communiqué wireless subscriber device MS at step 203 selects the 3 strongest pilot signals for use in establishing/maintaining the cellular communication connection. In this process, the RAKE receiver in the communiqué wireless subscriber device MS at step 207 continuously looks for the strongest pilot signals to ensure the continuation of the cellular communication connection. The communiqué wireless subscriber device MS at step 204 decodes the
15 pilot signals and locks on to the synch channel of selected forward CDMA channels having the strongest pilot signals.

At step 205, the communiqué wireless subscriber device MS switches to selected Traffic channels, one per selected forward CDMA channel as determined by a communiqué identifier stored in the profile memory PS and demodulates the signals
20 received therein and at step 206 outputs the demodulated multi-media output to the appropriate devices of the user interface NTR of the communiqué wireless subscriber device MS for use by the subscriber.

As described herein, the overhead required in point to point cellular communications to manage hand-offs between cells within the cellular communication
25 network is considerable and continuous, since many of the wireless subscriber devices served by the cellular communication network are mobile in nature. In the communiqué system for cellular communication networks, the need for this overhead in processing call hand-offs is reduced since the wireless subscriber device is not provided with a unique communication link, but shares this link with many other wireless
30 subscriber devices. There are a number of communiqué implementations that can be overlaid on this standard handoff process.

Specific attributes of the Autonomous Registration Cycle for the "Receive Only" communiqué wireless subscriber device include:

- 35 1. Adjacent cell pilots are $W=0$ (Walsh Code zero) but have unique sequence offsets to identify a particular base station from other base stations.
2. The synchronization or synch channels have the same offset as the pilot.

3. The static traffic channels conveying the narrowcasted content are always fixed within the network deployment using a K=3 algorithm. The communiqué wireless subscriber devices are pre-programmed to know which code sequence to look for (a priori knowledge of where the narrowcast resides).

5 4. Communiqué wireless subscriber devices are in continual soft or softer handoff.

5. All Walsh code assignments are static.

6. K=3 can be an omni cell grouping or a sector grouping.

7. Forward Paging Channels are not used.

10 8. Traffic Channel carries content and network overhead (as an in-band signaling protocol).

Non-Interactive Bi-Directional Transmission With Subscriber Registration

Figure 7 illustrates in block diagram form a typical assignment of cells in a cellular communication network for a non-interactive bi-directional transmission with subscriber registration mode of operation of the communiqué system for private virtual narrowcasts 100, where a plurality of cells are transmitting Communiqué signals, with each cell using any frequency and any Walsh (PN) code for a selected Communiqué.

This mode of operation enables the cellular communication system to select any repeat pattern of cells, any assignment of Walsh codes for a transmission to thereby enable communiqué services. The communiqué wireless subscriber device MS communicates with the Base Station Subsystem 131 for channel assignment spoofed registration purposes to receive free communiqué services. Thus, the communiqué wireless subscriber device MS does not require a unique MIN for this free communiqué services mode of operation, since billing or authorization is not required. This mode of operation can also be described as a receive-only mode of content delivery, with a bi-directional communication channel administration capability.

However, for subscription services, as shown in Figure 7, at step 701, the communiqué wireless subscriber device MS scans for pilot signals from the Base Station Subsystems that serve the coverage area in which the communiqué wireless subscriber device MS is operational. If the communiqué wireless subscriber device MS detects a Pilot Channel signal from another Base Station Subsystem 141, that is sufficiently stronger than that of the present Base Station Subsystem 131, the communiqué wireless subscriber device MS determines that an idle handoff should

occur. Pilot Channels are identified by their offsets relative to the zero offset pilot PN sequence and typically are the Walsh Code 0 for each channel. The communiqué wireless subscriber device MS at step 702 groups pilot offsets into sets describing their status with regard to pilot searching. The communiqué wireless subscriber device MS
5 at step 703 selects the 3 strongest pilot signals for use in establishing/maintaining the cellular communication connection. In this process, the RAKE receiver in the communiqué wireless subscriber device MS at step 710 continuously looks for the strongest pilot signals to ensure the continuation of the cellular communication connection. The communiqué wireless subscriber device MS at step 704 decodes the
10 pilot signals and locks on to the synch channel of the 3 selected forward CDMA channels having the strongest pilot signals.

At step 705, the communiqué wireless subscriber device MS registers with the Base Station Subsystem 131 using their unique ESN and SSD, but a common MIN that is used for communiqué purposes to spoof the base station subsystem 131 into
15 recognizing the communiqué wireless subscriber device MS without requiring a unique identity for the communiqué wireless subscriber device MS. In addition, the fraud prevention system (software) in the Mobile Telephone Switching Office 106 is disabled for Communiqués since the fraud system rejects multiple simultaneous MINs at different geographic locations. This feature is designed to prevent cloning fraud (more of an
20 artifact for analog versus digital) although multi-MIN fraud detection is used in digital systems as well. The Base Station Subsystem 131 verifies the authorization of this communiqué wireless subscriber device MS to receive the requested service, identifies the inbound call to the communiqué wireless subscriber device MS (shared by potentially many wireless subscriber devices) at step 706 via the Paging channel used
25 by the communiqué wireless subscriber device MS to request this service and, in response to control signals received by the communiqué wireless subscriber device MS from the Base Station Subsystem 131, the communiqué wireless subscriber device MS at step 707 changes to the identified traffic channel that carries the selected Communiqué. The communiqué wireless subscriber device MS at step 709 remains
30 in a soft handoff mode to ensure uninterrupted reception of the Communiqué and also at step 708 outputs the received multi-media data to the user.

In this scenario, the issue of "push/pull" transmissions was not mentioned. The subscriber at communiqué wireless subscriber device MS can receive "push" data

transmissions from a source which are directed to all subscribers of this service by the base station flood paging the MIN associated with this Communiqué. Thus, the communiqué wireless subscriber device MS would potentially have multiple MINs, with one for point to point traditional cellular communications and one for each of the

5 communiqué services to which the subscriber enrolls. Alternatively, the communiqué wireless subscriber device MS can have a single MIN that includes a Communiqué address embedded in the application layer of the application software of the communiqué wireless subscriber device MS that filters the content received by the communiqué wireless subscriber device MS. This filter function distributes the

10 Communiqué access control to the communiqué wireless subscriber device MS to thereby allow the subscriber to access only portions of the MIN enabled received content. Thus, when the communiqué wireless subscriber device MS is active in the service area, the flood page of one of the subscriber's MINs on the paging channel alerts the subscriber of the presence of a Communiqué transmission. The subscriber

15 can activate communiqué wireless subscriber device MS to receive this transmission or can reject the transmission by operating appropriate buttons on the communiqué wireless subscriber device MS. The reverse path on this communiqué channel is disabled, since there are many subscribers simultaneously registering for the Communiqué.

20 The Mobile Telephone Switching Office 106, Base Station Controller (BSC) 132, 142, 152 and Base Station Transceiver (BST) 133, 143, 144, 153 need appropriate software and control revisions to not alarm or error when no reverse path transmission on the traffic channel is received from the communiqué device (mobile or fixed). For the provision of subscription or toll services via the non-interactive bi-directional

25 transmission with subscriber registration mode of operation of the communiqué system for private virtual narrowcasts 100, a plurality of cells transmit Communiqué signals, with each cell using any frequency and any Walsh (PN) code for a selected Communiqué. This mode of operation enables the cellular communication system to select any repeat pattern of cells, any assignment of Walsh codes for a transmission

30 to thereby enable not only free communiqué services but also subscription services. The communiqué wireless subscriber device MS communicates with the base station 102 for registration purposes, but does not enter an interactive mode once registration is accomplished. Thus, the communiqué wireless subscriber device MS does not

require a unique MIN for this mode of operation, since the subscription billing and authorization can be implemented using the ESN and/or SSD of the communiqué wireless subscriber device MS or other such unique identifier.

5 The difference with this process compared to that of Figure 2 is that the registration process of step 705 consists of the communiqué wireless subscriber device MS transmitting the spoofing MIN as well as the SSD and/or ESN to the Base Station Subsystem 131 in a brief data exchange on the reverse CDMA paging channel to log the subscriber in to the selected subscription or toll services. If required, the subscriber can use the biometric device MU to authenticate the purchase of services, since the
10 immutable physical characteristic measured by the biometric device BU guarantees the identity of the subscriber. The forward page to the communiqué wireless subscriber device MS can include the Traffic channel identification of the subscribed services and the communiqué wireless subscriber device MS responds on the reverse CDMA channel with the subscriber registration information. Much of the communications to
15 effect soft handoff and registration can be carried in-band on the reverse CDMA channel.

To summarize, some of the attributes of this particular embodiment include:

1. Walsh assignments can be dynamic. This provides flexibility in planning and deploying the network.
- 20 2. Not constrained to K=3 architectures. This enables improved management of self-interference.
3. The system manages handoffs: soft, softer and hard.
4. Enables subscription types of narrowcast services.
5. Supports free narrowcasts.
- 25 6. Does not support interactive narrowcasts.
7. Can do a hard handoff if necessary.

The following are architectural features of this topology:

1. All communiqué wireless subscriber devices have the same MIN.
2. Subscription billing/authorization is done through means other than the
30 MIN by using other unique identifiers such as the ESN (Electronic Serial Number) or SSD (Shared Secret Data). Alternatively, a NID (Narrowcast ID) could be created however this doesn't exist today.

3. Base Station Subsystems (BSS) are “spoofed” into thinking a call (inbound to the communiqué wireless subscriber device) is always in place and needs to always be added whenever requested.

4. Fraud prevention software needs to be “spoofed” also. Disable fraud software for a given MIN.

5. Minimize reverse access channel paging congestion by priority assignment less than circuit switched voice traffic.

6. “Continuous” flood page to a specified MIN on the forward paging channel.

10 Flood page has lower priority than circuit switched call pages.

7. Overall objective is to minimize forward paging channel congestion.

8. Disable reverse path traffic channel on communiqué wireless subscriber device and error/loss measurement of carrier software at BTS/BSC. The reverse path traffic channel is disabled because the system is incapable of supporting of very large numbers of simultaneously transmitting communiqué wireless subscriber devices on one reverse traffic channel.

Interactive Bi-Directional Transmission With Subscriber Registration

This type of communiqué wireless subscriber device has the highest level of functionality and complexity. It adds two-way communiqué capability to the “Receive Only, Two-Way Admin Overhead” communiqué wireless subscriber device described above. This capability can be termed “Two Way Narrowcast Reception/Transmission, Capable of Bi-Directional Administrative Systems Overhead” to emphasize the fact that the content transmission as well as the administrative information transmissions are bi-directional. The registration process for this communiqué wireless subscriber device MS is identical for that described above in Figure 7 for the non-interactive transmission with subscriber registration, but the communiqué wireless subscriber device MS also has the capability to transmit data in the reverse direction, to the Base station Subsystem.

In essence, this communiqué wireless subscriber device MS is a fully functional cellular phone capable of receiving one-way communiqués in a blind radio like fashion (not transmit capable). It is also capable of receiving one-way communiqués with bi-directional administrative overhead capability for registration and channel assignment. And the final functionality is reverse path (mobile to base) communiqué capability. This

reverse path communiqué capability can be implemented in a packet or circuit switched manner and can be coordinated or uncoordinated with respect to the one-way communiqué being transmitted from the base station. In practice, the preferred method is to architect this channel in a packet switched mode enabling multiple end-users access on a demand basis using a variety of protocols such as aloha or slotted aloha. While it is possible to have the reverse communiqué channel be circuit switched, this architecture is not designed for thin route types of data transfer from large numbers of end-users.

In summary, the "Transmit/Receive, Two-way Admin Overhead" communiqué wireless subscriber device MS is a full function device capable of three modes of operation with the highest functionality being the mode wherein the device is capable of reverse path communiqués. The reverse path communiqué can have the same registered subscribers as the coincident forward path communiqué or the reverse path communiqué could have a unique narrowcast group. The communiqué group for reverse path (mobile to base) communiqués does not have to coincide with the communiqué assignments on the forward path (base-to-mobile). Of importance, each communiqué wireless subscriber device MS now becomes a content source in a peer-to-peer architecture where each communiqué wireless subscriber device has the ability to send information to other users in its reverse path communiqué group.

20 **Communiqué Wired Subscriber Devices**

Communiqué wired subscriber devices WS are end-user devices that are capable of receiving narrowcasted content from broadband wireline-based communication networks that deploy next generation architectures such as DOCSIS. This narrowcasted content (communiqué) is multimedia in nature and simultaneously delivered to multiple communiqué wired subscriber devices. The narrowcasted content includes:

- audio (music, radio shows, news and the like),
- video (MTV-like videos, news, live traffic cams and the like), and
- data (text information, stock quotes, graphical information and the like).

30 The end-user devices, herein now called communiqué wired subscriber devices WS, are, in essence, next generation radio-television-internet receivers for generally unidirectional receipt of transmissions that have a highly targeted demographic focus. The above-noted content are conveyed by wireline transmissions, with the preferred

delivery means being next generation broadband wireline-based communication networks in a one-to more than one broadcast or narrowcast mode of operation. The demographic groups used for narrowcasting can range in size from a small neighborhood to a sports stadium as determined by the granularity of the broadband wireline-based communication network being re-used to deliver the narrowcasted content. The content delivery region and conveyed content are dynamically changeable depending on the associated demographics.

Communiqué wired subscriber devices are multi-media devices and, as such, output digital content to the end-user in the following forms:

- 10 Digital Audio
- Digital Video
- Digital Internet
- Digital Text
- 15 Digital Graphics

The architecture of a communiqué wired subscriber device is derived from modifications to existing and planned wired device architectures. The implementation of Narrowcast/Communiqué capability is largely performed in software/firmware, with the communication interface for this device remaining very similar to present and future standards. In essence, the architecture is a novel systems overlay leveraging what already exists.

Figure 14 illustrates, in block diagram form, the architecture of a typical embodiment of the communiqué wired subscriber device WS of the present invention. This particular embodiment of the communiqué wired subscriber device WS is disclosed to illustrate the concepts of the invention and is not intended to limit the application of the disclosed concepts. The communiqué wired subscriber device WS is equipped with a processor CONTROL that operates pursuant to instructions that are stored in MEMORY and the subscriber profile information stored in profile memory PS, as is described below.

The communiqué wired subscriber device WS is equipped with transmitter TRANS and receiver RCV circuits well known in cable television communications for providing voice and data communications via a voice data switch VDS. The communiqué wired subscriber device WS includes a user interface NTR that is equipped with the apparatus necessary to enable the user to receive and input data.

For example, the user interface NTR includes a display device VD that produces a human sensible visualization of the data that is received and audio output device LS to produce a human sensible audio output of the received data. The user interface can also include audio input devices MIC and keyboard K (and/or mouse or pointer device) to enable the user to input data in an audible or textual form, respectively. The user interface NTR can optionally include a biometric interface BM that measures an immutable physical characteristic of the user, such as a fingerprint, retina scan, and the like, to enable the communicé wired subscriber device WS to authenticate the identity of the user. In addition, the communicé wired subscriber device WS can include sensors, or an interface SENI that is adapted to connect to one or more sensors SM1, SM2, to measure selected parameters, such as ambient temperature, velocity, altitude, and the like.

In the case of a receive-only communicé wired subscriber device, it is evident that the implementation described above can be simplified, since the transmitter TRANS is not needed and many of the other capabilities are likely not required.

Dynamically Configured Wireless Local Area Networks

There is presently an effort to manufacture wireless subscriber devices that are interoperable, via short-range, low power communications. These wireless subscriber devices are formed into a small wireless network on an ad hoc basis. Each wireless subscriber device seeks out and configures itself with a resident server device, which can be a permanent access point, such as a communicé wired subscriber device WS that is interconnected for example with the communicé system for private virtual narrowcasts 100 or another communicé wired subscriber device.

An example of such a philosophy is presently embodied in the Bluetooth Special Interest Group which uses a wireless paradigm for interoperability of devices using a carrier frequency of between 2,400 MHz and 2,483.5 MHz to support a plurality of data transfer channels, which are either asymmetric or symmetric, as a function of the application that is enabled. The communicé wired subscriber device WS therefore can include a dynamic network system DNS that includes a local radio frequency (RF) transceiver LT, a baseband link control unit BU, associated link management control software/hardware LM and an antenna system PA. The transmitter portion of the local radio frequency transceiver LT mixes the baseband information with the frequency hopping local oscillator to generate a frequency-modulated carrier. The receiver portion

of the local radio frequency transceiver LT down converts and demodulates the RF signal using the same oscillator in the adjacent time slot. The local radio frequency transceiver LT supports both point-to-point and point-to-multi-point connections. A plurality of wireless subscriber devices so enabled can dynamically configure themselves into a "piconet", with one wireless subscriber device designated as the master and the remaining units as slaves, or a peer-to-peer configuration. The piconet is distinguished from other similar piconets in the vicinity by the frequency hopping sequence. The baseband protocol can be used for both circuit and packet switched transmissions. Synchronous links can be established for voice connections, using reserved time slots, while asynchronous links are dedicated for data transmissions.

For example, the dynamic network system DNS may be used to serve a single auxiliary handset unit H and/or terminal device HT and can optionally be multiplexed to serve a plurality of auxiliary handset units H, H' and/or terminal devices HT, HT'. The auxiliary handset H and/or terminal device HT can be hard wired to the communiqué wired subscriber device WS or can be a wireless unit H', HT' of limited communication range that interconnects with the communiqué wired subscriber device WS via radio frequency transmissions as noted above. In the multi-user application, the communiqué wired subscriber device WS can comprise a "mini-cell" wherein the various auxiliary handsets H, H' and/or terminal devices HT, HT' are managed by the communiqué wired subscriber device WS in a manner analogous to that performed by the typical cell site/MTSO. Thus, the handset units H, H' and/or terminal devices HT, HT' can be of a different technology, with the communiqué wired subscriber device WS performing an integration function as well as the multiplexing function. The handsets H, H' can be personal communication system (PCS) units, pagers, code division multiple access (CDMA) units, or any other wireless communication devices which are in use by individuals. The communiqué wired subscriber device WS receives the signals generated by the various handset units and formats (if necessary) the data contained in these transmissions into the format used for the radio link transmissions to the cell site. The communications in the reverse direction are managed in a complementary manner as is well known. The handset units H, H' can each have a unique identification which enables the underlying cellular communication network to communicate with the unit. The communiqué wireless subscriber device MS can therefore perform the handset registration function by polling the handset units extant in the space served by

the electronics unit to thereby identify these units. This unit identification data can then be transmitted to the cell site via the control channels to enable the cellular network to ascertain the location of these particular units.

The communiqué wired subscriber device WS can implement the three above-
5 noted functionalities using communiqué address and communiqué device identifier data in a manner that is analogous to that described above for the communiqué wireless subscribed device MS. The communication protocol that is implemented for this purpose is dependent on the underlying communication protocol extant in the particular wireline-based communication network that serves the communiqué wired subscriber
10 device WS.

Content Delivery

The content of the Communiqués can vary widely and include but are not limited to: free information, subscription-based information, toll-based information, and the like, as noted above. The content can be locally generated or remotely generated, with the
15 propagation of the information to the various cell sites being implemented in a number of ways. Figures 1 A - 1C illustrate in block diagram form the overall architecture of a typical content delivery network for the communiqué system for private virtual narrowcasts 100. In particular, there is a Program Manager 113 that functions to receive the program source information from multiple sources and migrate information
20 to selected cell sites for transmission to the subscribers served by these cell sites. The Spatial-Temporal Content Manager 114 defines the geographic area or demographic population or subscriber interest group that are the metrics used to transmit information to subscribers who populate the target audience for narrowcast transmissions. The Spatial-Temporal Content Manager 114 also can include the selection of frequencies
25 and PN codes that are used by each cell site to transmit the Communiqués to subscribers. The basic content delivery network is independent of the existing radio frequency cellular communication network, but is cooperatively operative with the cellular communication network. Thus, it is expected that part of the functionality described herein for the content delivery network can be part of or integrated with the
30 cellular communication network, as a matter of expediency. The degree to which the content delivery network is incorporated into the cellular communication network or even into the communiqué system for private virtual narrowcasts 100 varies and does not diminish the applicability of the concepts embodied in the communiqué system for private virtual narrowcasts 100.

35 As shown in block diagram form in Figures 1A - 1C, the sources of data for the communiqué system for private virtual narrowcasts 100 can be varied, and a few typical

content sources are shown here to illustrate the concepts of the communiqué system for private virtual narrowcasts 100. In particular, the communiqué system for private virtual narrowcasts 100 is connected to a plurality of content sources. The sources can be a remotely located program source for providing for example network news, such as
5 a national network station 122 that is connected via a satellite uplink 123 and satellite 124 to a satellite downlink 126 and forwarded to satellite interface 117 that is part of the communiqué system for private virtual narrowcasts 100 or can use the Public Switched Telephone Network and trunk interface 116B. Alternatively, the program source can be a local program source 120 for local news and information, that is connected via a
10 data communication medium, such as the Internet 107, to an Internet server interface 115 of the communiqué system for private virtual narrowcasts 100. In addition, a program source, such as local program source 121 is connected via the Public Switched Telephone Network 108 to a trunk interface 116A of the communiqué system for private virtual narrowcasts 100. In addition, a local terminal device 127 can be
15 connected via interface 110 to the communiqué system for private virtual narrowcasts 100 for inputting information. The various program sources provide information of various types, including but not limited to: news, advertisements, traffic, weather, travel information, and the like.

The communiqué system for combined cellular and wireline communication
20 networks 100 also includes a local mass storage memory 119 for storing control instructions for use by processor 118 as well as program material received from the various program sources identified above. A processor complex that includes Spatial-Temporal Content Manager 114 to manage the definition of the cells to which a particular Communiqué is transmitted controls the communiqué system for private
25 virtual narrowcasts 100. Furthermore, the communiqué system for private virtual narrowcasts 100 includes Program Manager 113 to integrate information received from the various program sources into Communiqués that are transmitted over selected Traffic channels of the forward CDMA channel within one or more cells as identified by the Spatial-Temporal Content Manager 114. The Communiqués generated by the
30 Program Manager 113 are transmitted to the various Base Station Subsystems 131-151 identified by the Spatial-Temporal Content Manager 114 either directly or via the associated Mobile Telephone Switching Office 106. The Program Manager 113 functions to assemble program streams as described below and transmits the program streams containing the Communiqués via a selected communication medium, such as
35 the Public Switched Telephone Network 108, using network interface 116A, or some other communication medium, such as an IP network.

Content Domain Narrowcast

An alternative to the use of centralized, predetermined Communiqués that are formatted at the communiqué system for private virtual narrowcasts 100 and transmitted via the Base Station Subsystems 132, 142, 152 to the wireless subscriber devices, the
5 delivery of information can be effected by using the content domain as a distribution format. The content domain enables the communiqué system for private virtual narrowcasts 100 to achieve a dynamic, changeable broadcast/narrowcast without modifying or reconfiguring the RF network domain.

In particular, a broadband program stream containing all information for all cells
10 can be created by the Spatial-Temporal Content Manager 114. This information, such as that described below with respect to Figure 8, is delivered to the Mobile Telephone Switching Office 106 for distribution to all relevant Base Station Subsystems 132, 142, 152. The Base Station Subsystems 132, 142, 152 can either parse the information contained in the frame into a plurality of Communiqués for transmission in their cells,
15 such as the plurality of cells included in coverage areas A-C shown on Figure 12. Alternatively, the information can be passed directly to the wireless subscriber devices for parsing therein. However, it is expected that the bandwidth limitations in the communication link from the Base Station Subsystems 132, 142, 152 to the wireless subscriber devices render the former parsing scheme preferable to parsing at the
20 wireless subscriber device. Yet another alternative is the hierarchical parsing of the information, where the Base Station Subsystems 132, 142, 152 parse the received information frame into a plurality of subframes of similar format and reduced content for transmission to the wireless subscriber devices for further parsing of the subframes into the individual Communiqués. This process utilizes the available bandwidth to provide
25 the wireless subscriber devices with the information necessary to produce a number of Communiqués, thereby eliminating the need for the Base Station Subsystems 132, 142, 152 to communicate with the wireless subscriber devices to switch channels to access other Communiqués. This distributed switching and hierarchical information delivery architecture thereby reduces the Paging channel traffic for the Base Station
30 Subsystems 132, 142, 152.

The Spatial-Temporal Content Manager 114 controls the actual information that is transmitted from each cell site by sending program stream parsing control signals to routers contained in the Base Station Controllers 132, 142, 152 at each cell site which then, on a distributed basis, re-assemble the broadband program stream containing all
35 information for all cells into a data stream that is only relevant for that particular cell. By grouping cells as shown on Figure 12 into "content similar blocks" or more specifically coverage areas A-C, the Spatial-Temporal Content Manager 114 has

commanded the routers at the cell sites to parse the broadband program stream identically for the grouped cells (as predefined by the systems programming or a content programming operator), the effect of a narrowcast can be achieved without modifying the RF network architecture. From the subscriber's perspective, he is only receiving narrowcast information when in the grouped cells' transmission range. As the subscriber moves from one region to another, the broadcast/narrowcast Communiqué received may be different depending on the spatial programming of the Spatial-Temporal Content Manager 114. Also, over time, a given narrowcast region may change in its physical shape or disappear altogether.

10 The operation of this Spatial-Temporal Content Manager 114 is illustrated in flow diagram form in Figure 11 where at step 1101 each cell in the cellular communication network the is served by the communiqué system for private virtual narrowcasts 100 is assigned a unique address, using a selected protocol, such as TCP/IP. At step 1102, the cells are grouped into collections comprising coverage areas. The program content in the form of Communiqués are selected at step 1103 and assigned to destinations, using the cell addresses assigned at step 1101. At step 1104, the Communiqué schedule is defined in terms of time of transmission, duration of transmission, duration of narrowcast region, temporal and/or spatial characteristics of narrowcast region, and the like. Finally, at step 1105, the identified Communiqués are transmitted to the selected cells using the assigned cell addresses. The transmission can occur on a real time basis where the Communiqués are provided to the cells at the time they are to be broadcast, or the Communiqués can be distributed in advance of transmission and stored for future transmission. The process of Figure 11 then returns to either step 1101 where address information is updated as needed or step 1102 where the cell groupings are modified and the process cycles through the above-noted steps as required.

One disadvantage of this particular distributed re-assembly approach is with a CDMA architecture designed to operate in soft or softer handoff (this limitation is not present in an analog or TDMA architecture since they do not operate in soft handoff).

30 Since the data streams must be identical for the wireless subscriber device to operate in soft handoff, as a subscriber transitions from the boundary of one narrowcast region to another, the number of cell sites available to be in soft handoff is varying and could be zero. One method for solving this limited shortcoming is to broadcast the broadband content stream from all sites all the time and put the router function within the wireless subscriber device itself. Commands on how to re-assemble the content is based on an subscriber's physical location and the signaling is done on an in-band basis (i.e. the data parsing commands are contained within the traffic channel in a TDM fashion).

This reduces the effective available bandwidth for a narrowcast since much of the broadband content is not for a given subscriber and is "thrown" away by a given subscriber. It also places higher computing power at the wireless subscriber device in order to parse the data. Again, if soft handoff is not required for reliable CDMA operation, the aforementioned limitation is not a concern and parsing can be done at the cell site. And, in either parsing scheme, distributed at the cell site or distributed at the wireless subscriber device, if the content is overlaid on an analog or TDMA network, the soft handoff limitation is not an issue.

Management of Spatial-Temporal Control of Distributed Content

Conceptually, the programming of the broadcast/narrowcast regions for management by the Program Manager 113 is done initially by content operators (people) who pre-program the system for content distribution. As a general principle, the content can be classified into groups such as:

- | | | |
|----|---------------------|---|
| 15 | Diurnal Narrowcasts | (e.g. AM/PM traffic reports along highways) |
| | Special Narrowcasts | (e.g. football game, art-in-the-park) |
| | Campuses | (e.g. schools, work complexes) |
| | General | (e.g. news weather sports) |
| | Other | |

Much of the programming is repetitive and only needs to be done once i.e. a diurnal narrowcast. One-time only events can be programmed in advance, and say for a football game, can retain all of the programming features such as its spatial coverage extent, and only need to be recalled and given a new narrowcast execution time window. From a user interface perspective, imagine a GUI that displays all of the cells available for a broadcast/narrowcast wherein an operator can select given cells to form a narrowcast region. This region is then saved as a narrowcast group. Next, the operator goes to another GUI screen that contains all available broadcast information and selects which content files are appropriate for the narrowcast group just previously designed. Last, the operator defines the time window for the narrowcast. By repeating this process and building a database of spatial, temporal and content information, all requisite knowledge is programmed into the system for a 24 hour 7 day operation in the Spatial-Temporal Content Manager.

The database, at a minimum, has the following fields:

- Start Time
- Stop Time
- 35 Narrowcast Cell Grouping
- Broadcast Cell Grouping
- Narrowcast Content Stream

Broadcast Content Stream

Other

Format of the Forward CDMA Channel for Communiqué Architectures

Figure 5 illustrates in block diagram form a typical configuration of the Base Station Subsystem 131 to wireless subscriber device 101 forward CDMA channel used for Communiqué transmissions in cellular communication networks. As noted above, the typical Base Station Subsystem 131 to wireless subscriber device 101 forward CDMA channel comprises a predefined bandwidth centered about a selected carrier frequency. The bandwidth of the selected channel as well as the selected carrier frequency is a function of the technical implementation of the base station of the cellular network and is not discussed further herein. The communication space for Communiqué transmissions is typically divided into a plurality of segments: Pilot 501, Synchronization (Synch) 502, Traffic 503. The Traffic 503 segment is further divided into a plurality of channels Ch1-Ch62. Each traffic channel represents a communication space for a selected wireless subscriber device 101. The plurality of traffic channels CH1-CH62 as shown in Figure 5 are assigned the remaining Walsh codes. Each Traffic channel consists of data traffic as well as in band signaling transmitted from the Base Station Subsystem 131 to the wireless subscriber device 101, as noted above.

Typical Content Transmission Format

Figure 8 illustrates in block diagram form a typical signaling protocol for use in the communiqué system for private virtual narrowcasts 100. A frame 800 can be used to transmit both content as well as control information and a broadcast guide. The frame 800 is shown in one typical form, although the particulars of the frame 800 can vary as a function of the use of this element. In particular as noted above, a broadband program stream containing all information for all cells can be created by the Spatial-Temporal Content Manager 114. This information is delivered to the Mobile Telephone Switching Office 106 via a communication medium, such as the Public Switched Telephone Network 108, for distribution to all relevant Base Station Subsystems 132, 142, 152. The Base Station Subsystems 132, 142, 152 can either parse the information contained in the frame into a plurality of Communiqués for transmission in their cells, such as the plurality of cells included in coverage areas A-C shown on Figure 12. Alternatively, the information can be passed directly to the wireless subscriber devices for parsing therein. Yet another alternative is the hierarchical parsing of the information, where the Base Station Subsystems 132, 142, 152 parse the received information frame into a plurality of subframes of similar format and reduced content for transmission to the wireless subscriber devices for further parsing of the subframes into the individual Communiqués.

The frame 800 has a plurality of constituent parts, including a Header 801, Administration 802, Data 803 and Trailer 804. The Header 801 and Trailer 804 are used to identify the beginning and end of the Frame 800 and can include error check bits to ensure proper transmission of the data. The Administration 802 is used to convey various control information to the Base Station Subsystem and to the wireless subscriber device. The Administration 802 can include a Radio Frequency Configuration segment 811, which defines the Traffic channel on which the frame is to be broadcast. The remaining segments of the Administration 802 consist of a "Program Guide" 812 which includes a schedule segment 821 to define the time at which the frame is to be transmitted and the information parsing data, content definition segment 822 the defines the content of the data section 803 of the frame 800 (and optionally the information parsing data), Authorization segment 823 which defines the type of service associated with the content of the data section 803 of the frame 800. Advertisements 824 can also be included in the Program Guide 812, along with optional special services 825, such as traffic reports 841, public service announcements 842 and the like 843. Other segments 826 can optionally be included. In the content segment 822, the content definitions describe the information that is available, and a plurality of such elements is shown to illustrate this concept, including but not limited to: music 831, 832, sports 833 and other programs 834.

It is evident that this example of a format is simply an illustration and it is expected that numerous variations can be implemented that fall within the scope of the concept taught herein. In particular, in the case of hierarchical parsing, the frame that is transmitted to the wireless subscriber device would be a reduced content version of frame 800, since the content would be reduced to match the bandwidth capabilities of the communication link from the Base Station Subsystems 132, 142, 152 to the wireless subscriber devices.

The dynamic adaptation of the narrowcast coverage areas and the selection of information transmitted to subscribers located in these narrowcast coverage areas is accomplished by the communiqué system for private virtual narrowcasts 100, operating in cooperation with the Mobile Telephone Switching Office 106. The Program Manager 113 and the Spatial-Temporal Communiqué Manager 114 operate to determine: the presence of subscribers in a particular cell, the presence of external events, the movement of the subscribers from cell to cell, the available programs that are to be transmitted to the subscribers, and then process this information to create the Communiqués and the narrowcast coverage areas. This is accomplished in part by the communication between the communiqué system for private virtual narrowcasts 100,

operating in cooperation with the Mobile Telephone Switching Office 106 in which the above-noted information is exchanged. In addition, the communiqué system for private virtual narrowcasts 100 maintains data in memory 119 that defines the call coverage area of the cells so that the external events can be mapped to locales and their associated serving cells.

Program Stream Management

Figure 13 illustrates a typical stream for a plurality of communication channels as applied to the typical dynamic coverage areas. Communiqués are formed by the Program Manager, 113, and the Spatial Temporal Communiqué Manager 114, and delivered to the cellular system via the Public Switched Telephone Network 108, which is comprised of a grouping of various architectures (circuit, packet switched (e.g. TCP/IP), ATM, frame relay, satellite and so on) to convey the information from the communiqué system for private virtual narrowcasts 100, to the Mobile Telephone Switching Office 106, to Base Station Subsystem 131,141,151 and ultimately to Base Station Transceiver 133,143,144,153 for transmission as a broadcast/narrowcast Communiqué to the various wireless subscriber devices. The Communiqués can be labeled in any manner appropriate for composite system operation, and for this example, the Communiqués are given alpha designators (A, B, C and so on). A given Communiqué may have spatial relevance and could be targeted by the Spatial Temporal Communiqué Manager 114, for delivery to a specific region.

As shown in Figure 13, the example Communiqué A comprises programming from sources:

National Source 122, content residing at key media nodes (in a centralized manner);

Regional Source 120, content residing at a plurality of media nodes attached to the Internet (in a centralized/decentralized manner);

Local Source 121, content residing at a plurality of media nodes connected via the Local Exchange Carrier (in a decentralized manner);

Local Source 127, content residing at end-user nodes (in a decentralized manner). The content from Regional Source 120 is diverse in its substance and embodies the plethora of media available on the Internet (data, stock quotes, music, video, email, special interest, sports, news and so on). The content from National Source 122 comprises more general information that is applicable to many Communiqués such as news, weather and sports. The content from Local Source 127 is information gathered and conveyed by the end-user in an active or passive mode. An example of Active information is identifying that a particular lane on a particular

highway is blocked. Passive information may be reporting of outside air temperature.

To generate Communiqué A as shown in Figure 13, the Program Manager 113, collects and collates all available content from sources 120, 122 and 127 from the universe of All Content Sources and forms/creates/parses 120, 122 and 127 to the
 5 desired, predetermined information stream thereby creating Communiqué A. Communiqué A contains the following content in this example:

From Regional Source 120:

stock quotes (free to the end-user)
 music (channelized) (free/subscription to the end-user)
 10 composite traffic flow map (subscription to the end-user)
 other

From National Source 122:

news (free to the end user)
 weather (free to the end user)
 15 sports (free to the end user)
 other

From Local Source 127:

end-user traffic data (free to the network)
 end-user temperature data (free to the network)
 20 other

Each individual content stream can also contain advertising (typical for a free service). Typical subscription services would not contain advertising.

The Spatial Temporal Content Manager (STCM) 114, receives all Communiqués from the Program Manager 113, and assigns the communiqués for a given period of
 25 time to given cells to form narrowcast regions in the time domain. Communiqué A, which is the data payload for 803 delivered to a narrowcast region, is but one of many Communiqué—Narrowcast—Time pairings that occurs in the Spatial Temporal Communiqué Manager 114. In addition to Communiqué A:

Communiqué B is a diurnal narrowcast.
 30 Communiqué C is a special event narrowcast.

The Spatial Temporal Communiqué Manager 114, through repetitive programming, ensures that all cells, whether stand-alone or grouped into a narrowcast region, have content available 24 hours per day 7 days per week.

The programming described herein is deterministic meaning the content
 35 contained within a Communiqué, where a Communiqué is transmitted and how long a communiqué is transmitted is pre-programmed by the network operator. Another embodiment concerns dynamic active feedback from end-users within a given

narrowcast region to "inform" the Spatial Temporal Communiqué Manager 114, whether or not they are within the narrowcast region.

Private Narrowcast Groups

As noted above, the communiqué system for private virtual narrowcasts can serve a plurality of private narrowcast groups, each of which can comprise a virtual private network. These private virtual narrowcasts are typically not regularly scheduled events (although they may be), originated by a content provider, but are initiated by a virtual private narrowcast "host" on an as needed basis, such as determined by the host, and directed to a selected group of subscribers. Thus, the subscribers in a particular narrowcast coverage area are typically members of a predetermined group and the only ones authorized to participate in a particular narrowcast. Multiple simultaneous virtual private networks can be extant in a cell site coverage area and the coverage area of each narrowcast can differ from the others that are supported by that cell site. Therefore, as shown in Figure 15, a plurality of narrowcasts can co-exist in a communication space, as described above. The cell sites C1-C10 each provide a coverage area that serves a plurality of subscribers. Each of the cell sites C1-C10 can support a portion of one or more of the narrowcast coverage areas CA1-CA3, where the cell sites C1-C3, C5-C7 in narrowcast coverage area CA1 are delimited by solid lines, the cell sites C3-C4, C8-C10 in narrowcast coverage area CA2 are delimited by dashed lines, and the cell sites C5-C7 in narrowcast coverage area C3 are delimited by alternating dashed and solid lines. As shown in Figure 15, the cell sites in a particular narrowcast coverage area can be contiguous cells, non-contiguous cells, combinations of contiguous and non-contiguous cells. The locations of the selected cells can be geographically dispersed and may span large distances. As noted above, a number of virtual private network transmissions can be supported by each communication channel (RF carrier) via multiplexing the communication channel into a plurality of slots and the narrowcast wireless communication device can parse the received content to access the authorized one(s) of the received virtual private network communiqués by selecting the slot that carries the communiqué. Alternatively, a plurality of the slots can be assigned to the communiqué or even the entirety of the communication channel.

An example of an application of this concept is the creation of a "conference call" among a plurality of diverse locations. For example, a business having locations in a number of states wishes to tie all of their locations together to receive a presentation

and optionally to enable participants to respond in a bi-directional manner. The cell site C3 covers the Washington, D.C. office of the business, the cell site C4 covers the Arlington, VA office of the business, cell site C8 covers the Denver, CO office of the business, cell site C9 covers the Boulder, CO office of the business, and cell site C10 covers the Dallas, TX office of the business. The employees located at the various offices can receive the narrowcast content via the telephone switching system that serves the particular office location, and employees who are out of their respective base offices can receive the narrowcast content via their communiqué wireless subscriber devices MS. Each office location can either receive a wireline-based narrowcast or can receive a wireless-based narrowcast as described below. Thus, this configuration of communication systems and devices is supported by the narrowcast architecture described above.

Figure 16 illustrates in block diagram form additional detail of a portion of the network configuration that supports the narrowcast coverage area described above (concentrating on only two of the plurality of offices noted above) and Figure 17 illustrates in flow diagram form the operation of the communiqué system for private virtual narrowcasts in executing the multi-location narrowcast network operation described above. In particular, the Denver, CO office is equipped with a conventional telephone switching system 1610 that contains a network 1611 that serves to interconnect a plurality of subscriber communication devices 1614-1 to 1614-n with a plurality of trunks T10 that interconnect the telephone switching system 1610 with the Public Switched Telephone Network PSTN in the conventional manner. The telephone switching system 1610 is also equipped with feature circuits, such as conference circuit 1612 and is also served by narrowcast wireless interface 1613, as is described below. Similarly, the Boulder, CO office is equipped with a conventional telephone switching system 1620 that contains a network 1621 that serves to interconnect a plurality of subscriber communication devices 1624-1 to 1624-m with a plurality of trunks T20 that interconnect the telephone switching system 1620 with the Public Switched Telephone Network PSTN in the conventional manner. The telephone switching system 1620 is also equipped with feature circuits, such as conference circuit 1622 and is also served by narrowcast wireless interface 1623, as is described below.

The network configuration shown in Figure 15 only discloses a portion of the communiqué system for private virtual narrowcasts 100 as shown in Figures 1A-1C for

simplicity of description. The cell sites C8 and C9 shown as serving the telephone switching systems 1610 and 1620 are equivalent to the MTSO 106 shown on Figure 1A. The remaining interconnections and details shown in Figures 1A-1C are not shown on Figure 15 and reference to Figures 1A-1C can be made to obtain the additional details of the communiqué system for private virtual narrowcasts 100 as described in conjunction with this example.

Narrowcast Wireless Interface for Wireline-Based Communication Systems

The narrowcast wireless interface 1613, 1623 consists of a narrowcast wireless communication device MS that has optionally been modified to interface with the network 1611, 1621 of the telephone switching system 1610, 1620. The narrowcast wireless interface 1613, 1623 is equipped with a processor CONTROL that operates pursuant to instructions that are stored in MEMORY and the subscriber profile information stored in profile memory PS, as is described below. The narrowcast wireless interface 1613, 1623 is equipped with transmitter TRANS and receiver RCV circuits well known in cellular communications for providing voice and data communications via a voice data switch VDS. The apparatus also includes antenna VPA, which is typically mounted on an exterior surface of the narrowcast wireless interface 1613, 1623 and coupled in well-known fashion to the transmitter TRANS and receiver RCV circuits by a duplexer. The power output of the transmitter TRANS can also be dynamically regulated as a function of the distance from the cell site transmitter antenna to ensure a relatively constant signal level, using the Power Control circuit presently available in many cellular radio systems.

The narrowcast wireless interface 1613, 1623 may also include a user interface NTR that is equipped with the apparatus necessary to enable the user to receive and input data. For example, the user interface NTR includes a display device VD that produces a human sensible visualization of the data that is received and audio output device LS to produce a human sensible audio output of the received data. The user interface can also include audio input devices MIC and keyboard K (and/or mouse or pointer device) to enable the user to input data in an audible or textual form, respectively. The user interface NTR can optionally include a biometric interface BM that measures an immutable physical characteristic of the user, such as a fingerprint, retina scan, and the like, to enable the narrowcast wireless interface 1613, 1623 to authenticate the identity of the user. The narrowcast wireless interface 1613, 1623 is

also equipped with a network interface to interconnect the narrowcast wireless interface 1613, 1623 with a port on the network 1611, 1621 as is well-known in telephone switching systems. Thus, the narrowcast wireless interface 1613, 1623 interconnects the telephone switching system 1610, 1620 with the associated cell sites C8, C9 of the cellular communication network.

A narrowcast can originate from a narrowcast source 1604, which can be any of the types of sources described above, or a telephone switching system, such as the telephone switching system that serves another of the offices. The narrowcast source 1604 can be a conference circuit within the telephone system which is linked with the conference circuits 1612, 1622 resident in the telephone switching systems 1610, 1620 via the narrowcast interfaces 1613, 1623. In addition, subscribers at individual narrowcast wireless communication devices, such as 1631-1, 1631-5 can be included in the coverage area of the narrowcast when these subscribers initiate a request to join the narrowcast or are paged. The access to the virtual private network formed by this interconnection of communication systems and devices can be by the traditional MIN, SSD and/or ESN assigned to each of the narrowcast interfaces 1613, 1623 and the individual narrowcast wireless communication devices 1631-1, 1631-5, or the non-interactive or interactive bi-directional transmission with subscriber registration mode of operation described above can be used to register these devices with the narrowcast. These narrowcast devices can be assigned a MIN that is unique to this virtual private network or to this particular virtual private network narrowcast session. To illustrate the operation of this system, the example of a virtual private network narrowcast that interconnects two telephone switching systems and a plurality of individual subscribers is used herein. In operation, the narrowcast source consists, for example, of an individual (narrowcast host) served, for example, by individual narrowcast wireless communication device 1631-5 who initiates a virtual private network narrowcast by initiating a communication connection to the communiqué system for private virtual narrowcasts 100 and dialing either a predetermined code that identifies the predetermined set of participants in the virtual private network, or dials the telephone number of one or more participants in the virtual private network. In the former case, the narrowcast host at step 1701 initiates a communication connection to an interface 116A to access the Program Manager 113, located in the communiqué system for private virtual narrowcasts 100 to enable entry of the virtual private network narrowcast

identification data at step 1702 via this communication connection. This virtual private network narrowcast data defines not only the narrowcast host, but also the various participants in the virtual private network narrowcast, which data can be pre-stored in the database 119 for access by the Program Manager 113 or input by the narrowcast host via this communication connection. The virtual private network narrowcast data is used by the Spatial-Temporal Content Manager 114 at step 1703 to interconnect the narrowcast host with the various participants in the virtual private network narrowcast and to route the communiqué data therebetween. For example, at step 1704 the Spatial-Temporal Content Manager 114 either dials the access number of the telephone switching system 1610 or transmits a page to the narrowcast wireless interface 1613, then at step 1705 the Spatial-Temporal Content Manager 114 can add other participants to the narrowcast who are served by telephone switching system 1610 via operation of conference circuit 1612 of the telephone switching system 1610 in well known fashion. At step 1706, the Spatial-Temporal Content Manager 114 can optionally add other locations, such as telephone switching system 1620 and participants served by telephone switching system 1620 as described above with respect to step 1705. Steps 1704-1705 can be repeated to add a number of telephone switching systems to the narrowcast virtual private network, as identified by the list provided to the communiqué system for private virtual narrowcasts 100 by the narrowcast host. Additionally, at step 1707, individual participants served by individual narrowcast wireless communication devices 1631-1, 1631-4 can be added by the Spatial-Temporal Content Manager 114 either dialing the telephone number of these devices to initiate a page to these individual narrowcast wireless communication devices 1631-1, 1631-4 or by simply narrowcasting the private virtual network communiqué to the cells in which these individual narrowcast wireless communication devices 1631-1, 1631-4 are operational, to enable them to participate in the virtual private network narrowcast. (Alternatively, the above-described steps can be executed manually by the narrowcast host.) Once all of the participants have been interconnected in the above-noted manner, the communiqué system for private virtual narrowcasts 100 enables the exchange of data among the participants in this narrowcast virtual private network communicate session.

A further variation is where the various participants initiate the connection to the virtual private network narrowcast by activating their respective individual narrowcast

wireless communication devices 1631-1, 1631-4 and narrowcast interfaces 1613, 1623 at a prearranged time. In any of these scenarios, the participants are interconnected to receive the narrowcasted content (communiqué) and can participate in either a receive-only mode or a bi-directional mode. The use of the virtual private network MIN
5 enables participants to be mobile and join the narrowcast from any location.

Narrowcast Chat Room

Figure 18 illustrates in block diagram form a network configuration that supports a chat room-like service from the communiqué system for private virtual narrowcasts
10 100. This extension of the virtual private network described above is a dynamic virtual private network where the participants are individuals who are served by individual narrowcast wireless communication devices 1801-1808 rather than telephone switching systems. These individuals can be persons who are members of a predetermined group, or a collection of individuals who may not have any prior relationship, such as a chat room type of communication. The narrowcast for this dynamic virtual private
15 network can be constrained to a predetermined narrowcast coverage area or can be dynamically defined as described above. The individual subscribers are assigned a MIN that identifies the virtual private network and enables participation in the virtual private network narrowcast. This configuration can be envisioned as a dynamic conference and may be served by a conference circuit that is located in the MTSO that
20 serves one of the cell sites that is located within the narrowcast coverage area.

As shown in Figure 18, the cell sites controlled by MTSOs 18M1 and 18M2 each serve a plurality of individual narrowcast wireless communication devices 1804, 1808 and 1801, 1803, respectively. Participation in this type of virtual private network narrowcast is typically in the bi-directional transmission with subscriber registration
25 mode of operation that was described above, where the plurality of participants can communicate with each other. There is typically a narrowcast host who initiates the virtual private network narrowcast and their individual narrowcast wireless communication device 1804 is dynamically provided with the features that enable the narrowcast host to add participants, delete participants, transfer control of the
30 narrowcast to another participant, terminate the narrowcast. If the narrowcast group defined by the MIN is not a transient group of individuals, the system can assign an identifier to the narrowcast group. For example, if the narrowcast group constitutes the members of a basketball team, when one of the team members initiates a narrowcast

to the narrowcast group, the individual narrowcast wireless communication devices 1801-1803, 1805-1808 are paged either individually or by the communiqué narrowcast being detected by these devices (for example, sensing the multiplexed content on an authorized communication channel) and the caller identification that is displayed can indicate the name of the basketball team as well as the identity of the narrowcast host.

These individuals can then activate their respective individual narrowcast wireless communication devices 1801-1803, 1805-1808 to join the virtual private network narrowcast. In such an instance, the coverage area of the narrowcast can be constrained for network efficiency purposes to a predetermined cell site or limited number of cell sites. Thus, the members of the virtual private network are uniquely identified and participate via the use of the virtual private network MIN that defines membership in the virtual private network.

The virtual private network narrowcast can be a transient event, where a group of individuals cooperate to perform a specific function and need to communicate while participating in this event. An example is a sporting event, such as a ski race, where the event support staff need to communicate among themselves, but are not able to use traditional wireline-based communication devices. Thus, in a ski race, the starters, course judges, medical personnel, and other support staff are distributed over a large area, yet can be in communication with each other via the virtual private network narrowcast, without the concern that non-authorized individuals will be able to communicate with the members of the narrowcast group. In this instance, each of the narrowcast wireless communication devices can be assigned a temporary MIN to authorize participation in the virtual private network narrowcast that relates to the event, which MIN is deactivated upon conclusion of the narrowcast session. Thus, each individual can use their own narrowcast wireless communication devices or can be provided with narrowcast wireless communication devices, which are programmed with the temporary event-related MIN.

In yet another example, unrelated individuals who wish to communicate with each other regarding a predetermined subject matter can be members of a predetermined virtual private network, where the MIN assigned to each of the individual narrowcast wireless communication devices 1801-1808 defines subscription to a predefined content specific narrowcast group. Thus, an individual who travels to a location that is not their home location can locate others who have similar interests by joining a virtual private network narrowcast that serves individuals who have the same

MIN. The roaming subscriber who wishes to join this virtual private network narrowcast can be advised of the time of initiation of the virtual private network narrowcast whenever the subscriber activates their individual narrowcast wireless communication devices 1801-1808 and receives directory information that relates to the subscriber's

5 MIN's. Participation in this virtual private narrowcast can be associated with membership in an organization, or may be a communication session that is open to members of the public who have an interest in the subject matter of the communications, in a traditional chat room format. Again, it is likely that there is a host for the session so that this individual selects the time of origination and duration of the

10 communication session. Furthermore, the host can be enabled to unilaterally drop participants from the session or authorize additional participants.

Distributed Application Device Control Using Narrowcast Technology

An additional use of the narrowcast technology is the distributed real-time control of application devices and/or the uploading of data, such as the reading of utility meters or utility load control. For example, utility meters are read on a scheduled, periodic

15 basis by having meter reader personnel physically visit each meter location to manually record the present meter setting. This data is then transcribed into a billing system for use in generating customer bills. This process is labor intensive, time consuming, costly, and prone to errors. There are numerous other application devices that can be

20 served as described the following example, and these devices can be sensor-based, or operable to perform a particular function. The utility meter example is simply selected as a convenient method of describing the operation of the system. In such applications, the control channel of the RF channel can be used if the bandwidth demand is low enough.

25 Figure 19 illustrates in flow diagram form the operation of the communiqué system for private virtual narrowcasts in executing the distributed application device control function, using the general architecture of Figure 18, where each of the wireless subscriber devices 1801-1808 shown therein comprise a narrowcast wireless interface that is connected to a utility meter and/or load. The communiqué system for private

30 virtual narrowcasts 100 implements a data retrieval operation, such as a utility meter reading function, by polling utility meters (the communiqué subscriber in this case), each of which is equipped with a narrowcast wireless interface as described above, on a group basis. The utility meter reading process (narrowcast host) can be activated at step 1901 at times when other system communication traffic is low to more efficiently

35 use existing bandwidth. There are numerous protocols that can be implemented to simplify this process. For example, each utility meter can be provided with a meter

reading MIN to enable this utility meter reading service, or utility meters can be grouped by location, with a plurality of utility meters in each coverage area sharing a one of a plurality of meter reading MINs. Each coverage area (cell) can serve a plurality of meter reading MINs, with each meter reading MIN being activated seriatim until all meter reading MINs have been polled. Within each coverage area, the communiqué system for private virtual narrowcasts 100 at step 1902 selects at least one of the plurality of meter reading MINs and at step 1903 activates a private virtual network narrowcast by transmitting a utility meter page via a narrowcast communiqué, to activate the selected group of utility meters that have been assigned that meter reading MIN. There can be a plurality of concurrently transmitted pages, using a multiplexed communication channel (such as an RF carrier) with each narrowcast wireless interface monitoring the transmission for a page that matches their assigned MIN. In response to the received page, all narrowcast wireless interfaces in the coverage area at step 1904 compare the transmitted page with their assigned MIN. If the MIN matches the data contained in the page, the narrowcast wireless interface is activated and at step 1905 initiates a service request on the reverse path to the communiqué system for private virtual narrowcasts 100. The service request is received at step 1906 to enable the requesting narrowcast wireless interface to join the virtual private network consisting of the plurality of narrowcast wireless interfaces sharing the same MIN. Each narrowcast wireless interface at step 1907 retrieves utility meter data from either its memory or the associated utility meter and transmits the utility meter data at step 1908 to the communiqué system for private virtual narrowcasts 100 on the reverse path. Contention for the return path can be handled in a traditional bus contention mode, where the plurality of narrowcast wireless interfaces substantially concurrently bid for access to the return path and the communiqué system for private virtual narrowcasts arbitrates among these requests until they are served. Alternatively, each narrowcast wireless interface can be programmed to time shift their service request initiation in response to the utility meter reading page so that the service requests are temporally distributed to thereby reduce contention.

The communiqué system for private virtual narrowcasts 100 responds to a service request from a narrowcast wireless interface at step 1906 noted above by using the SSD and/or ESN of the narrowcast wireless interface to select that narrowcast wireless interface and activate the data transfer of the utility meter data to the

communiqué system for private virtual narrowcasts 100. After each request has been served, at step 1909, the communiqué system for private virtual narrowcasts 100 determines whether additional service requests remain unserved. If so, processing returns to step 1906. When the plurality of narrowcast wireless interfaces for the
5 selected MIN has been served, the communiqué system for private virtual narrowcasts 100 returns to step 1902 and transmits a page using another of the plurality of meter reading MINs. This process continues until the plurality of meter reading MINs have been served and the process exits.

In an analogous application, the above-noted process can be adapted for
10 unidirectional control functions, where the application device is simply activated to perform a function in response to the narrowcast operation. As an example of this unidirectional control function, utility usage can be controlled using the same paradigm as with utility meter reading, where "rolling blackouts" can be implemented by signaling
15 groups of devices to either reduce usage or discontinue usage. The above-noted paging process is used to identify a plurality of devices that are selected to discontinue/reduce consumption and the service request initiation can be used to confirm the action taken by each narrowcast wireless interface. The MINs used can denote a class of service that is assigned to each location, such that there is a hierarchy of preferences among the locations. Various locations receive preferential service,
20 likely defined as part of the utility service agreement. This enables some subscribers to receive uninterrupted service, while others are subject to partial load shedding, while others are subject to total load shedding. A received page does not necessarily need to be answered by a reverse communication, and can simply be used to initiate a desired control function. Thus, the application device knows what action to take in
25 response to the received page from the communiqué system for private virtual narrowcasts.

Summary

The communiqué system for private virtual narrowcasts groups cells and/or cell
30 sectors to cover a predetermined geographic area or demographic population or subscriber interest group to transmit information to subscribers who populate the target audience for the narrowcast transmissions. The grouping of cells to form the communiqué coverage area for the narrowcast transmissions can be hierarchical in nature and consist of combinations of in-building wireless coverage areas, standard
35 terrestrial cells, non-terrestrial cells, wireline based communication networks, orchestrated in a hierarchical manner.

What is claimed:

1. A communiqué system for providing communiqué virtual private network communication services to subscribers, equipped with wireless subscriber devices, via
5 a cellular communication network that includes a plurality of cell sites, each of which provides a plurality of wireless communication channels in a cell that covers a predetermined volume of space around a cell site transmitting antenna, comprising:

means, responsive to a narrowcast host initiating a virtual private network narrowcast, for selecting at least one of said plurality of cell sites to provide a virtual
10 private network narrowcast communiqué communication service;

means for interconnecting said narrowcast host and a plurality of wireless subscriber devices participating in said virtual private network narrowcast via said selected at least one of said plurality of cell sites; and

means for routing information, constituting said virtual private network narrowcast
15 communiqué communication service, among said narrowcast host and a plurality of wireless subscriber devices participating in said virtual private network narrowcast via selected ones of said plurality of wireless communication channels in said selected at least one of said plurality of cell sites.

2. The communiqué system of claim 1 wherein said means for selecting
20 comprises:

means for identifying said plurality of wireless subscriber devices participating in said virtual private network narrowcast;

means for identifying a present location of each of said plurality of wireless subscriber devices participating in said virtual private network narrowcast; and

25 means for identifying ones of said plurality of cell sites corresponding to said identified present locations.

3. The communiqué system of claim 2 wherein said means for identifying said plurality of wireless subscriber devices participating in said virtual private network narrowcast comprises:

30 means, responsive to receipt of data that specifies a predefined virtual private network, for retrieving data from a memory that lists said plurality of wireless subscriber devices participating in said virtual private network narrowcast.

4. The communiqué system of claim 2 wherein said means for identifying said plurality of wireless subscriber devices participating in said virtual private network narrowcast comprises:

means for receiving data from said narrowcast host that lists said plurality of wireless subscriber devices participating in said virtual private network narrowcast.

5. The communicate system of claim 1 wherein said means for interconnecting comprises:

means for enabling each of said plurality of wireless subscriber devices to receive said information via said one of said plurality of wireless communication channels.

6. The communicate system of claim 5 wherein said means for enabling comprises:

means for identifying each of said plurality of wireless subscriber devices via a communicate address assigned to said plurality of wireless subscriber devices to enable the cell sites to recognize each of said plurality of wireless subscriber devices without requiring a unique identity for each of said plurality of wireless subscriber devices.

7. The communicate system of claim 6 wherein said means for identifying comprises:

means for assigning a common MIN as said communicate address assigned to said plurality of wireless subscriber devices to enable the cell sites to recognize each of said plurality of wireless subscriber devices without requiring a unique identity for each of said plurality of wireless subscriber devices.

8. The communicate system of claim 5 wherein said means for enabling comprises:

means for registering at least one of said plurality of wireless subscriber devices to uniquely identify said at least one wireless subscriber device; and

means for authorizing said at least one wireless subscriber device to receive a subscriber selected communicate.

9. The communicate system of claim 1 wherein said means for routing information operates in at least one information distribution mode selected from the class of information distribution modes including: push, pull, and combinations of push/pull information distribution modes.

10. The communique system of claim 1 wherein said means for selecting comprises:

means for defining a set of said cells to provide a communique communication service to at least one of: a predetermined geographic area, a demographic population,
5 and a subscriber interest group.

11. The communiqué system of claim 1 wherein said virtual private network narrowcast communiqué communication service comprises a conference call, said means for routing information comprises:

means for interconnecting a plurality of wireline subscriber devices with said
10 wireless subscriber devices to enable said plurality of wireline subscriber devices to participate in said virtual private network narrowcast.

12. The communiqué system of claim 1 wherein said virtual private network narrowcast communiqué communication service comprises a chat room, said means for routing information comprises:

means for enabling wireless subscriber devices to join said narrowcast host and
15 a plurality of wireless subscriber devices presently participating in said virtual private network narrowcast.

13. The communiqué system of claim 12 wherein said virtual private network narrowcast communiqué communication service comprises a chat room, said means
20 for routing information further comprises:

means for enabling said narrowcast host to control which of said plurality of wireless subscriber devices participate in said virtual private network narrowcast.

14. The communiqué system of claim 1 wherein said virtual private network narrowcast communiqué communication service comprises distributed device control,
25 said means for interconnecting comprises:

means for transmitting a page to a plurality of said wireless subscriber devices, each of which serves an associated application device.

15. The communiqué system of claim 14 wherein said virtual private network narrowcast communiqué communication service comprises application device data
30 retrieval, said means for interconnecting further comprises:

means for storing data indicative of a plurality of subsets of said plurality of wireless subscriber devices, each of said subsets identifying at least one of said plurality of wireless subscriber devices;

means for identifying at least one of said plurality of subsets of said plurality of said wireless subscriber devices; and

means for concurrently activating said identified at least one of said plurality of subsets.

5 16. The communiqué system of claim 15 wherein said virtual private network narrowcast communiqué communication service comprises application device data retrieval, said means for routing information comprises:

means for receiving data from each of said at least one of said plurality of wireless subscriber devices in each of said concurrently activated subsets.

10 17. The communiqué system of claim 16 wherein said virtual private network narrowcast communiqué communication service comprises application device data retrieval, said means for routing information further comprises:

means, responsive to receipt of data from every one of said at least one of said plurality of wireless subscriber devices in each of said concurrently activated subsets,
15 for terminating said interconnection with said at least one of said plurality of wireless subscriber devices in each of said concurrently activated subsets.

18. The communiqué system of claim 1 wherein said virtual private network narrowcast communiqué communication service comprises application device control, said means for interconnecting comprises:

20 means for transmitting a page to a plurality of said wireless subscriber devices, each of which serves an associated application device.

19. The communiqué system of claim 18 wherein said virtual private network narrowcast communiqué communication service comprises application device control, said means for interconnecting further comprises:

25 means for storing data indicative of a plurality of subsets of said plurality of wireless subscriber devices, each of said subsets identifying at least one of said plurality of wireless subscriber devices;

means for identifying at least one of said plurality of subsets of said plurality of said wireless subscriber devices; and

30 means for concurrently activating said identified at least one of said plurality of subsets.

20. The communiqué system of claim 19 wherein said virtual private network narrowcast communiqué communication service comprises application device control, said means for routing information comprises:

5 means for transmitting data to each of said at least one of said plurality of wireless subscriber devices in each of said concurrently activated subsets to control operation of an application device connected thereto.

21. A method of operating a communiqué system for providing communiqué virtual private network communication services to subscribers, equipped with wireless subscriber devices, via a cellular communication network that includes a plurality of cell sites, each of which provides a plurality of wireless communication channels in a cell that covers a predetermined volume of space around a cell site transmitting antenna, comprising the steps of:

15 selecting, in response to a narrowcast host initiating a virtual private network narrowcast, at least one of said plurality of cell sites to provide a virtual private network narrowcast communiqué communication service;

interconnecting said narrowcast host and a plurality of wireless subscriber devices participating in said virtual private network narrowcast via said selected at least one of said plurality of cell sites; and

20 routing information, constituting said virtual private network narrowcast communiqué communication service, among said narrowcast host and a plurality of wireless subscriber devices participating in said virtual private network narrowcast via selected ones of said plurality of wireless communication channels in said selected at least one of said plurality of cell sites.

22. The method of operating a communiqué system of claim 21 wherein said step of selecting comprises:

25 identifying said plurality of wireless subscriber devices participating in said virtual private network narrowcast;

identifying a present location of each of said plurality of wireless subscriber devices participating in said virtual private network narrowcast; and

30 identifying ones of said plurality of cell sites corresponding to said identified present locations.

23. The method of operating a communiqué system of claim 22 wherein said step of identifying said plurality of wireless subscriber devices participating in said virtual private network narrowcast comprises:

5 retrieving, in response to receipt of data that specifies a predefined virtual private network, data from a memory that lists said plurality of wireless subscriber devices participating in said virtual private network narrowcast.

24. The method of operating a communiqué system of claim 22 wherein said step of identifying said plurality of wireless subscriber devices participating in said virtual private network narrowcast comprises:

10 receiving data from said narrowcast host that lists said plurality of wireless subscriber devices participating in said virtual private network narrowcast.

25. The method of operating a communique system of claim 21 wherein said step of interconnecting comprises:

15 enabling each of said plurality of wireless subscriber devices to receive said information via said one of said plurality of wireless communication channels.

26. The method of operating a communique system of claim 25 wherein said step of enabling comprises:

20 identifying each of said plurality of wireless subscriber devices via a communique address assigned to said plurality of wireless subscriber devices to enable the cell sites to recognize each of said plurality of wireless subscriber devices without requiring a unique identity for each of said plurality of wireless subscriber devices.

27. The method of operating a communique system of claim 26 wherein said step of identifying comprises:

25 assigning a common MIN as said communique address assigned to said plurality of wireless subscriber devices to enable the cell sites to recognize each of said plurality of wireless subscriber devices without requiring a unique identity for each of said plurality of wireless subscriber devices.

28. The method of operating a communique system of claim 25 wherein said step of enabling comprises:

30 registering at least one of said plurality of wireless subscriber devices to uniquely identify said at least one wireless subscriber device; and

authorizing said at least one wireless subscriber device to receive a subscriber selected communique.

29. The method of operating a communique system of claim 21 wherein said step of routing information operates in at least one information distribution mode selected from the class of information distribution modes including: push, pull, and combinations of push/pull information distribution modes.

5 30. The method of operating a communique system of claim 21 wherein said step of selecting comprises:

defining a set of said cells to provide a communique communication service to at least one of: a predetermined geographic area, a demographic population, and a subscriber interest group.

10 31. The method of operating a communiqué system of claim 21 wherein said virtual private network narrowcast communiqué communication service comprises a conference call, said step of routing information comprises:

interconnecting a plurality of wireline subscriber devices with said wireless subscriber devices to enable said plurality of wireline subscriber devices to participate
15 in said virtual private network narrowcast.

32. The method of operating a communiqué system of claim 21 wherein said virtual private network narrowcast communiqué communication service comprises a chat room, said step of routing information comprises:

enabling wireless subscriber devices to join said narrowcast host and a plurality
20 of wireless subscriber devices presently participating in said virtual private network narrowcast.

33. The method of operating a communiqué system of claim 32 wherein said virtual private network narrowcast communiqué communication service comprises a chat room, said step of routing information further comprises:

enabling said narrowcast host to control which of said plurality of wireless
25 subscriber devices participate in said virtual private network narrowcast.

34. The method of operating a communiqué system of claim 21 wherein said virtual private network narrowcast communiqué communication service comprises application device data retrieval, said step of interconnecting comprises:

30 transmitting a page to a plurality of said wireless subscriber devices, each of which serves an associated application device.

35. The method of operating a communiqué system of claim 34 wherein said virtual private network narrowcast communiqué communication service comprises application device data retrieval, said step of interconnecting further comprises:

5 storing data indicative of a plurality of subsets of said plurality of wireless subscriber devices, each of said subsets identifying at least one of said plurality of wireless subscriber devices;

identifying at least one of said plurality of subsets of said plurality of said wireless subscriber devices; and

concurrently activating said identified at least one of said plurality of subsets.

10 36. The method of operating a communiqué system of claim 35 wherein said virtual private network narrowcast communiqué communication service comprises application device data retrieval, said step of routing information comprises:

receiving data from each of said at least one of said plurality of wireless subscriber devices in each of said concurrently activated subsets.

15 37. The method of operating a communiqué system of claim 36 wherein said virtual private network narrowcast communiqué communication service comprises application device data retrieval, said step of routing information further comprises:

20 terminating, in response to receipt of data from every one of said at least one of said plurality of wireless subscriber devices in each of said concurrently activated subsets, said interconnection with said at least one of said plurality of wireless subscriber devices in each of said concurrently activated subsets.

38. The method of operating a communiqué system of claim 21 wherein said virtual private network narrowcast communiqué communication service comprises application device control, said step of interconnecting comprises:

25 transmitting a page to a plurality of said wireless subscriber devices, each of which serves an associated application device.

39. The method of operating a communiqué system of claim 38 wherein said virtual private network narrowcast communiqué communication service comprises application device control, said step of interconnecting further comprises:

30 storing data indicative of a plurality of subsets of said plurality of wireless subscriber devices, each of said subsets identifying at least one of said plurality of wireless subscriber devices;

identifying at least one of said plurality of subsets of said plurality of said wireless subscriber devices; and

concurrently activating said identified at least one of said plurality of subsets.

40. The method of operating a communiqué system of claim 39 wherein said
5 virtual private network narrowcast communiqué communication service comprises application device control, said step of routing information comprises:

transmitting data to each of said at least one of said plurality of wireless subscriber devices in each of said concurrently activated subsets to control usage of an application device connected thereto.

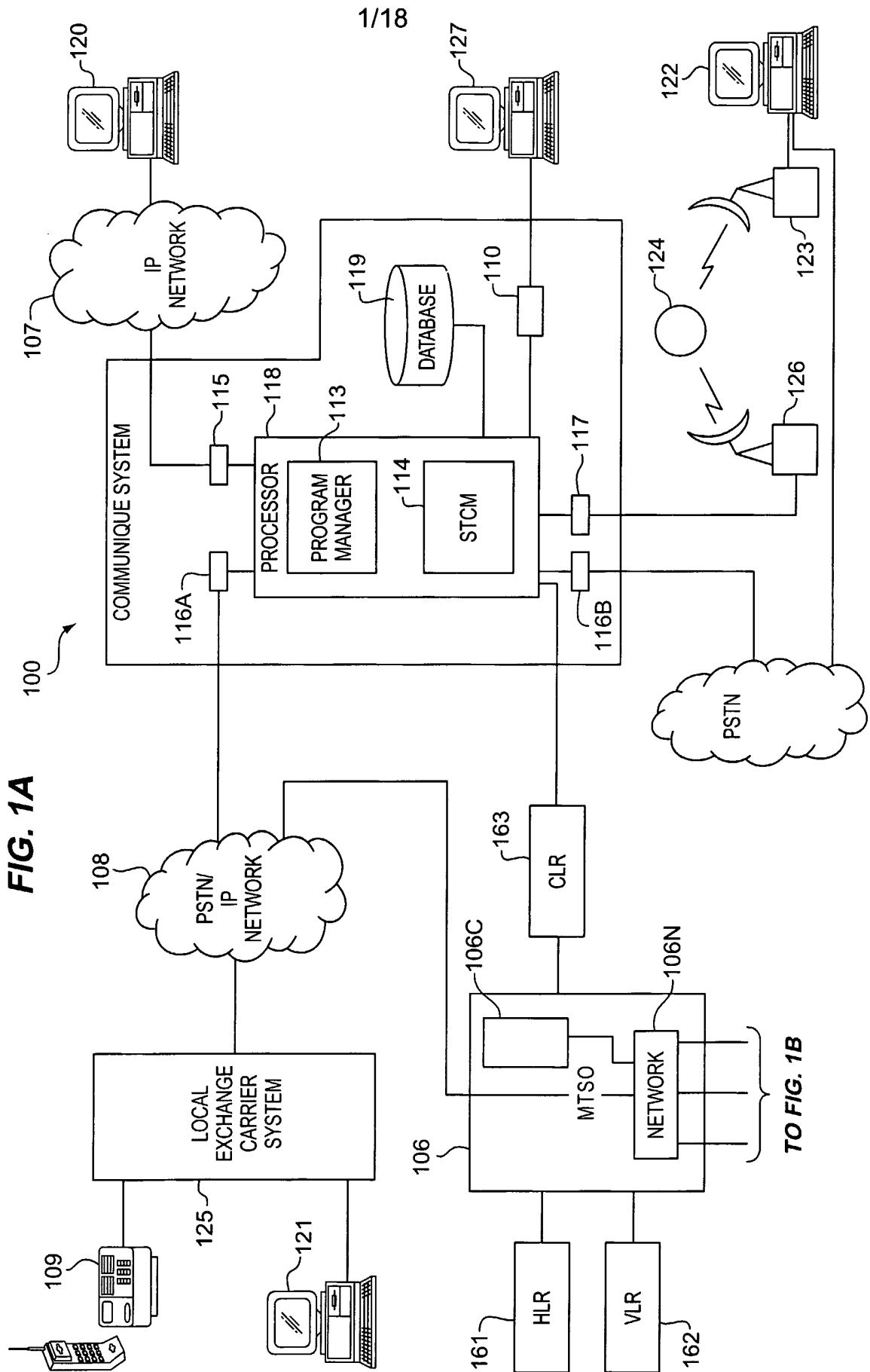

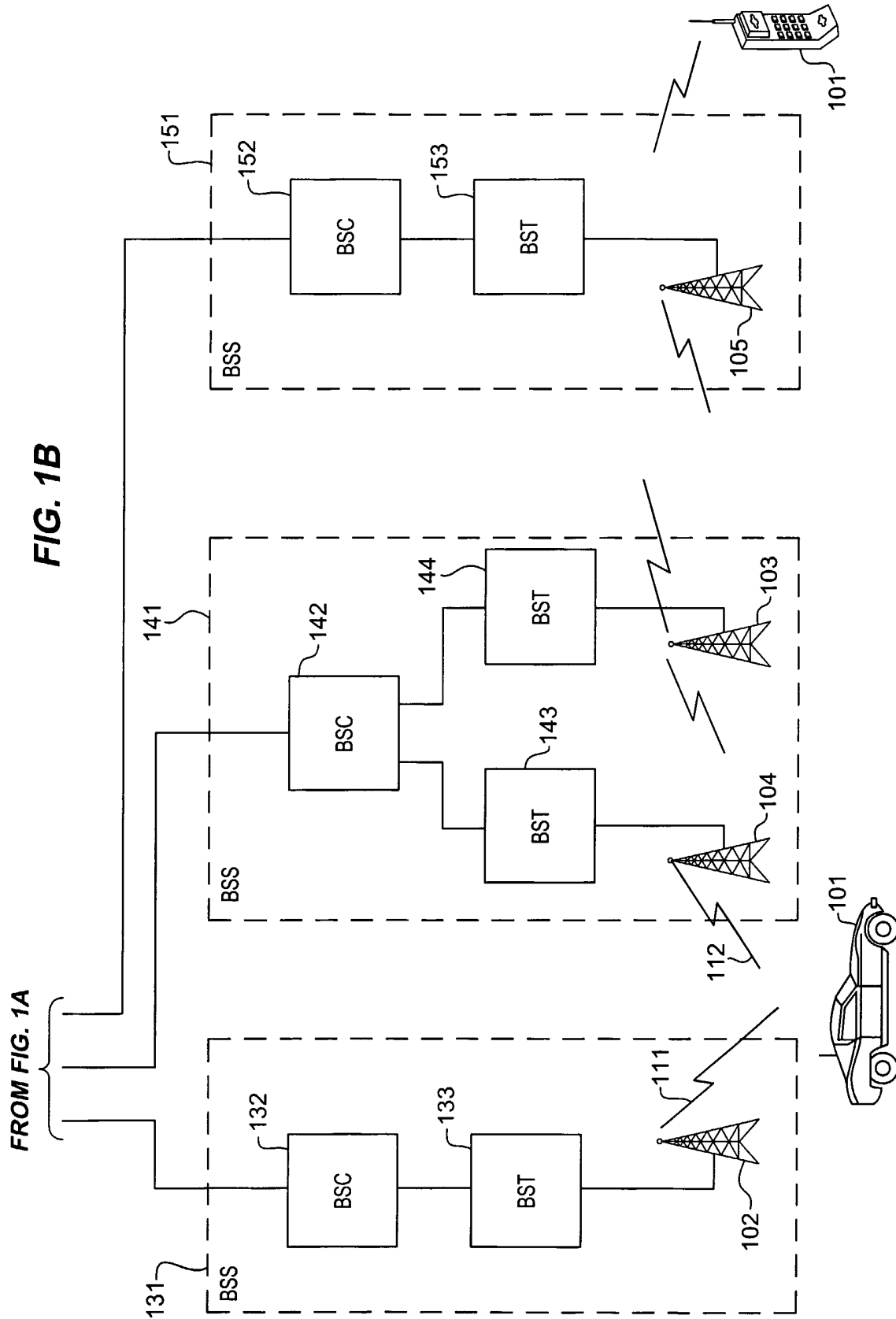

3/18

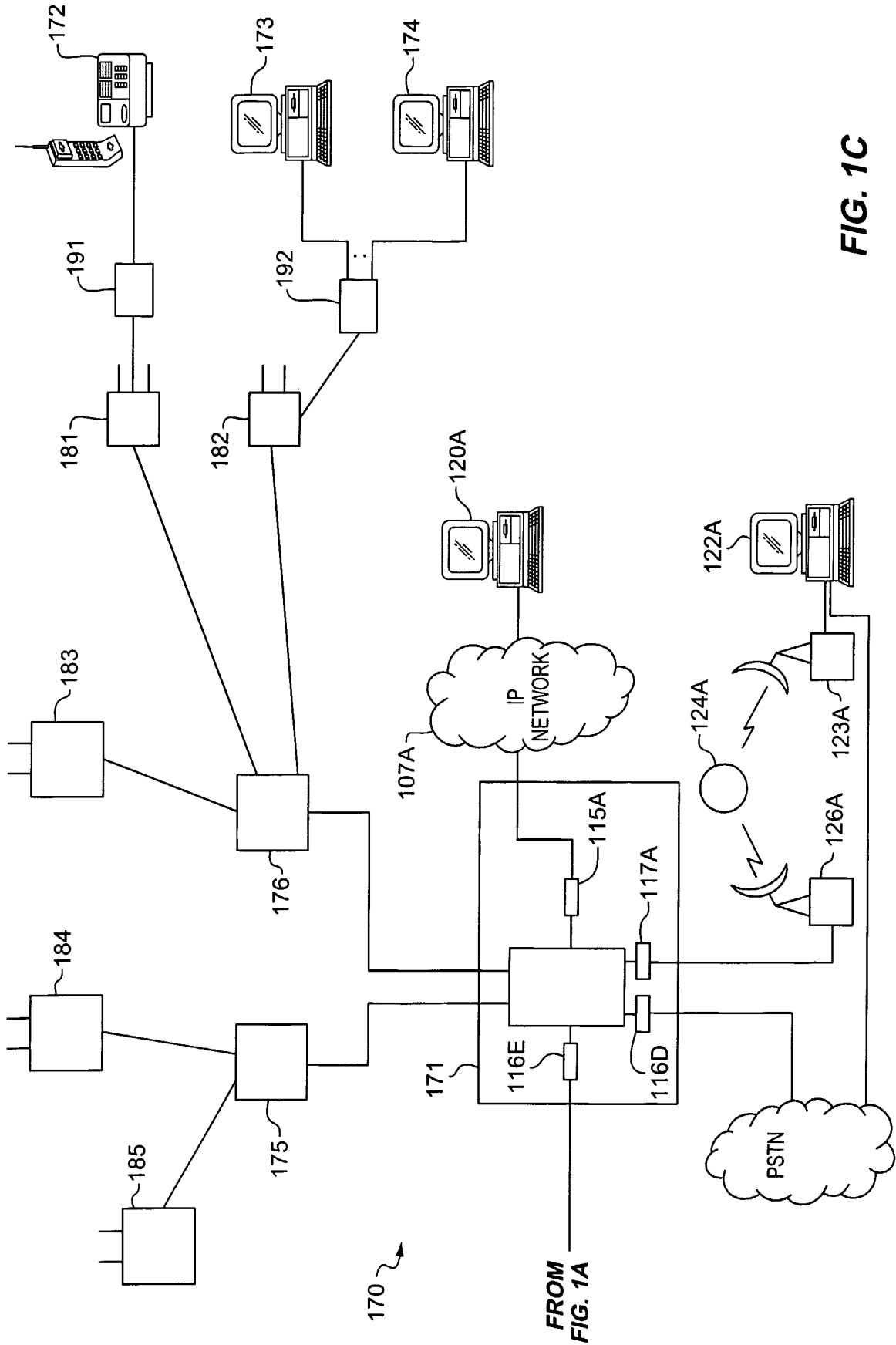
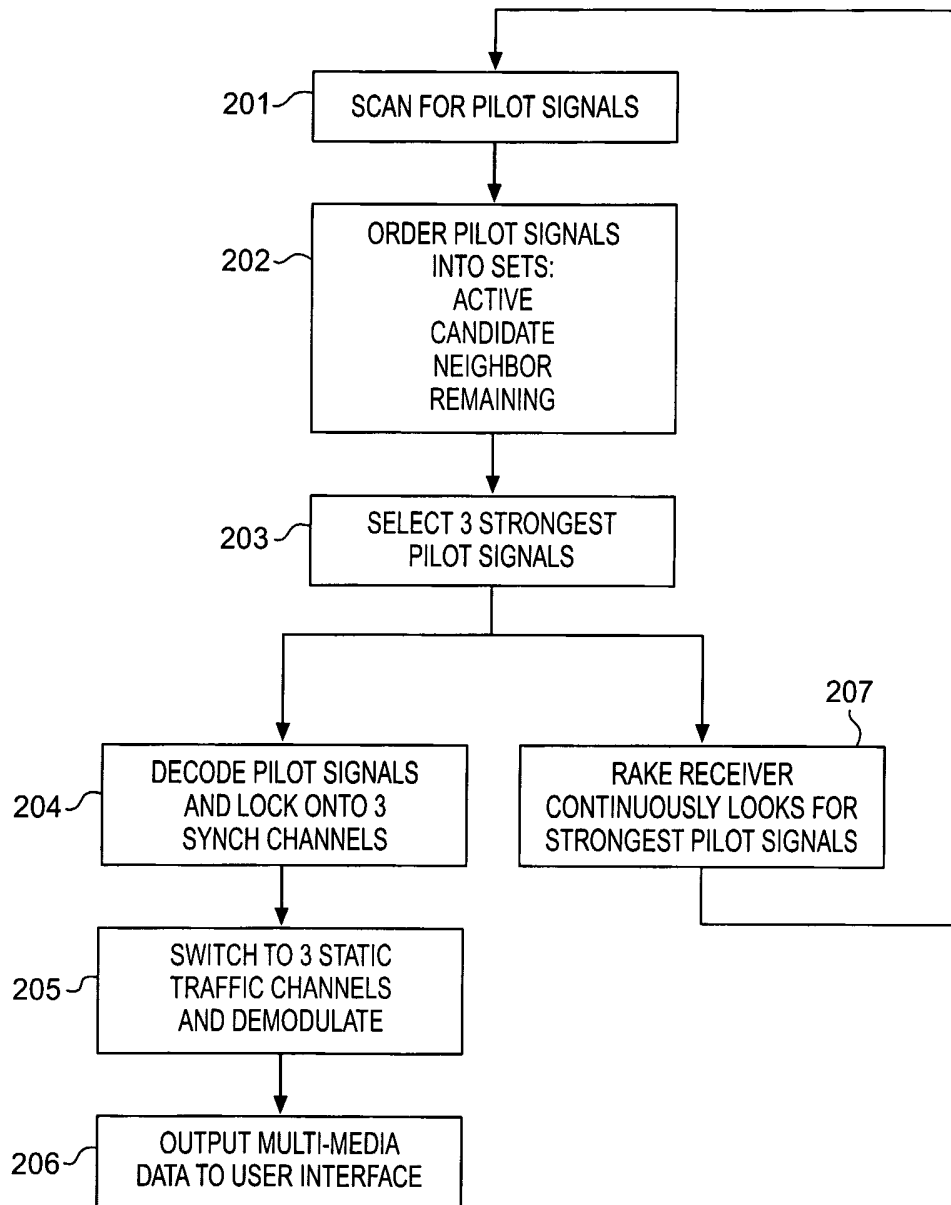

FIG. 1C

FIG. 2



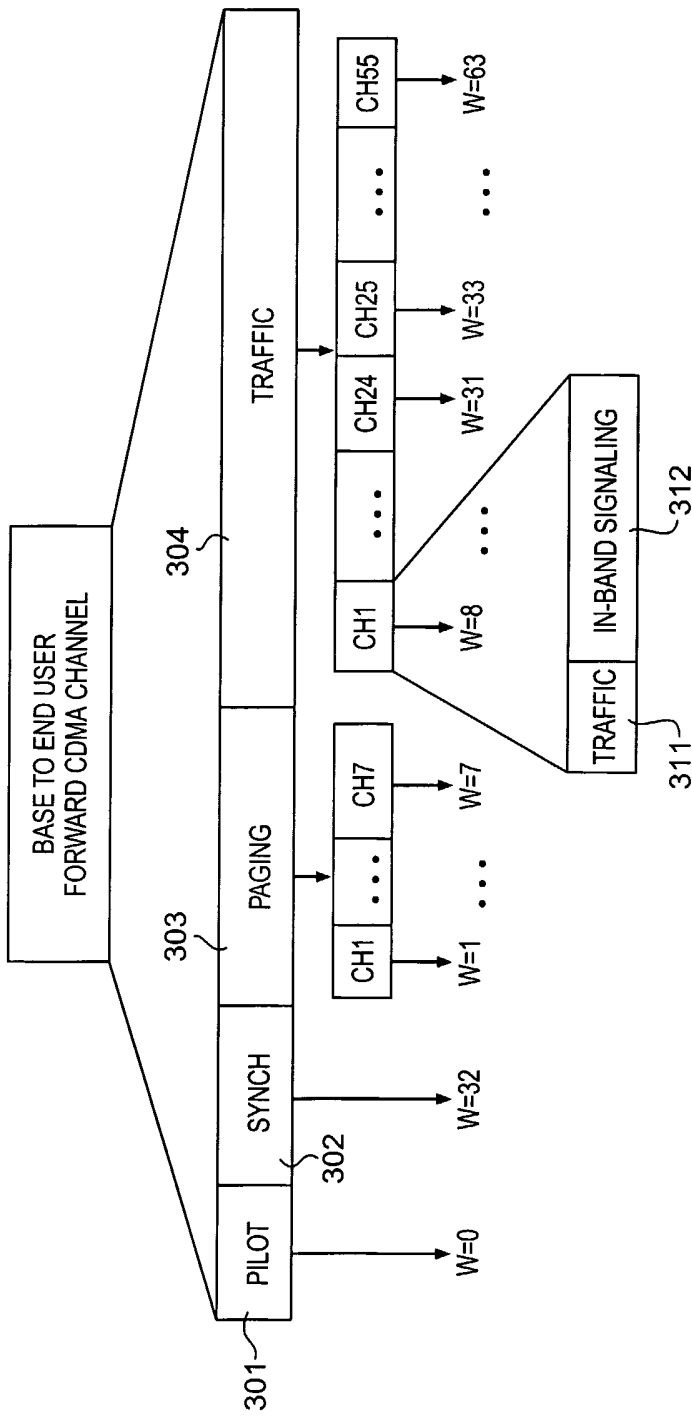

FIG. 3

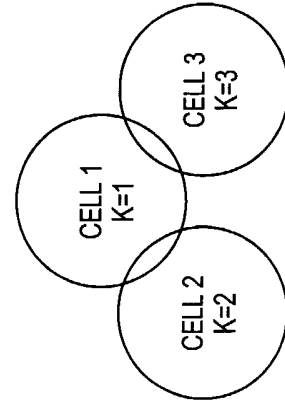

FIG. 4

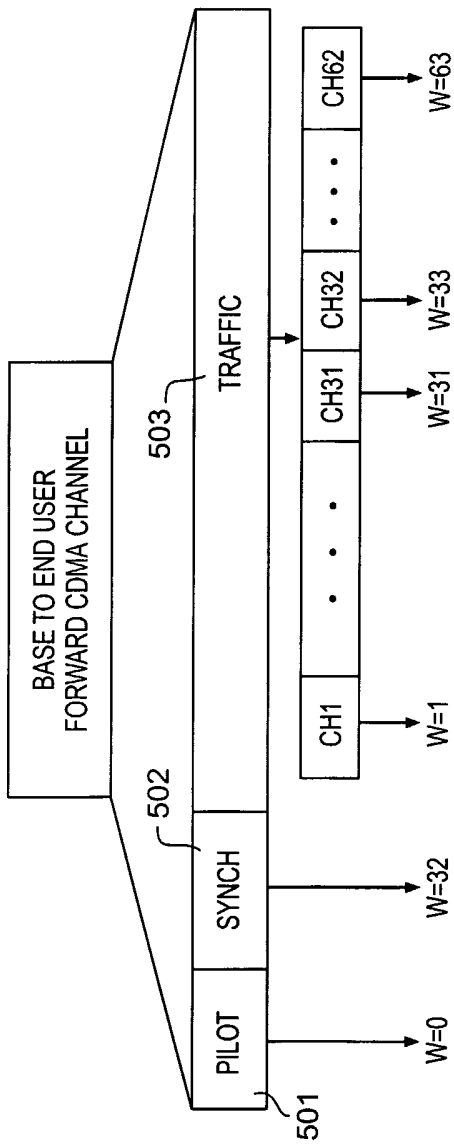

FIG. 5

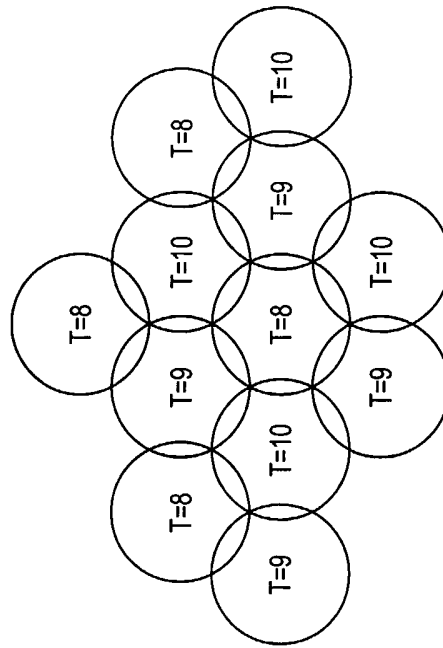
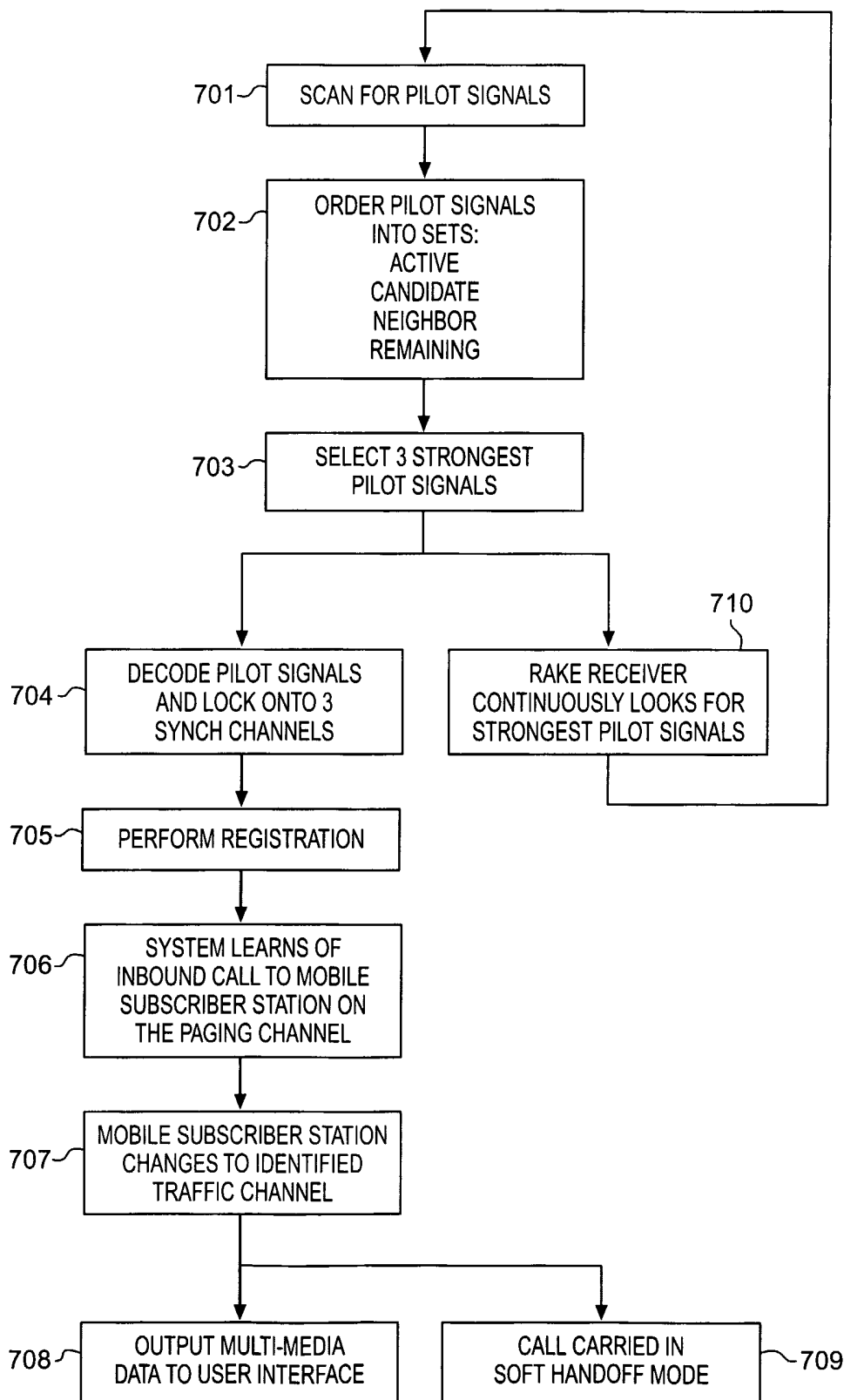

FIG. 6

7/18

FIG. 7



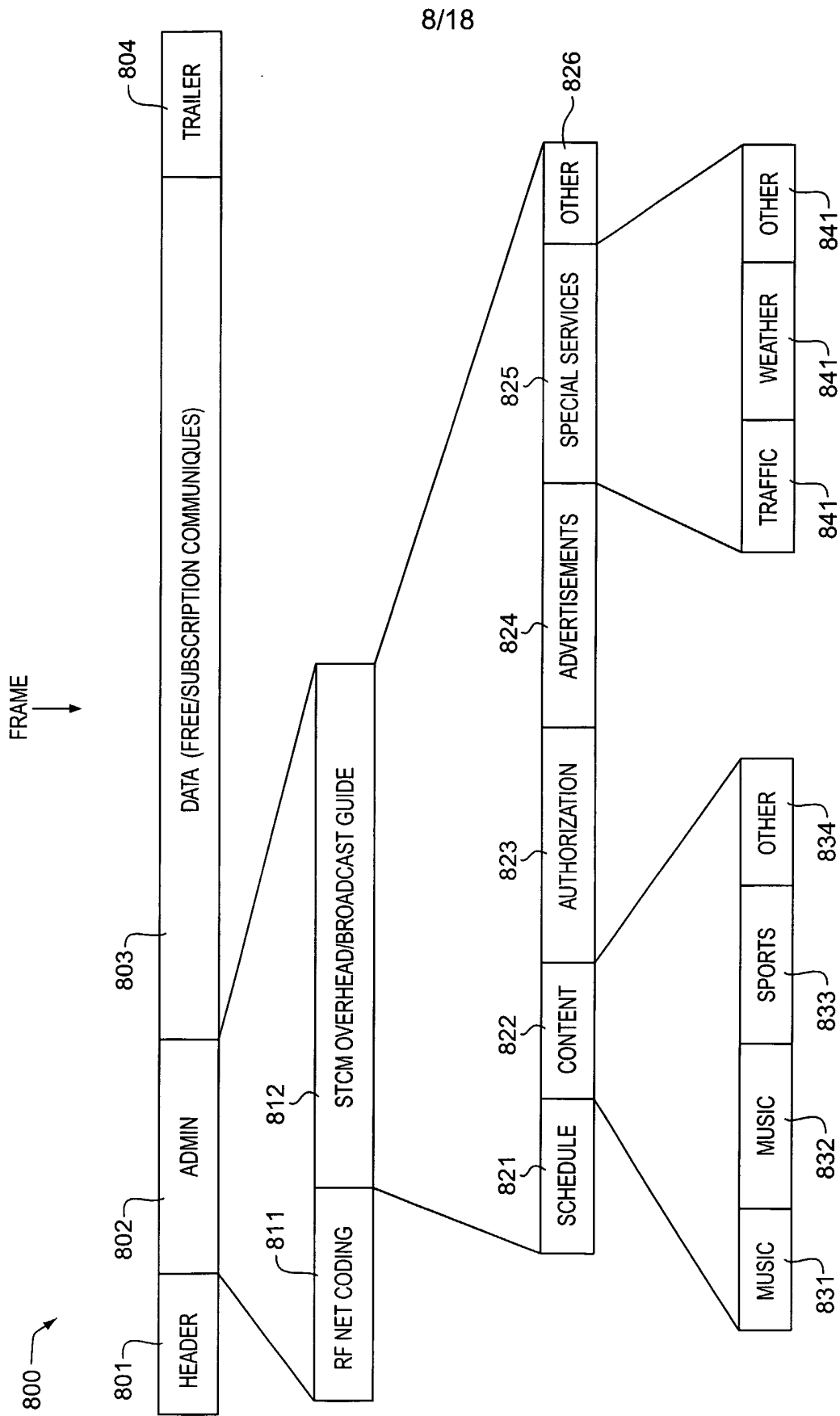
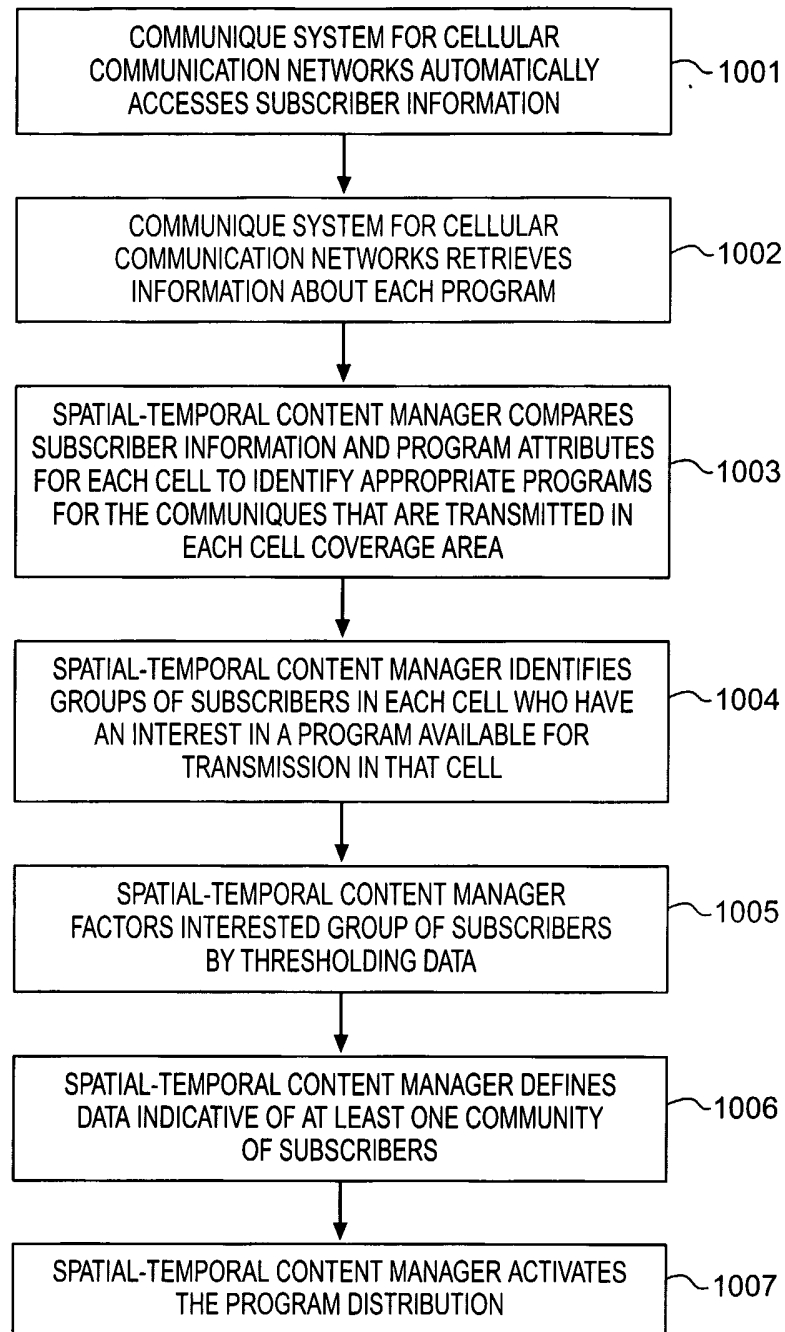

FIG. 8

10/18

FIG. 10

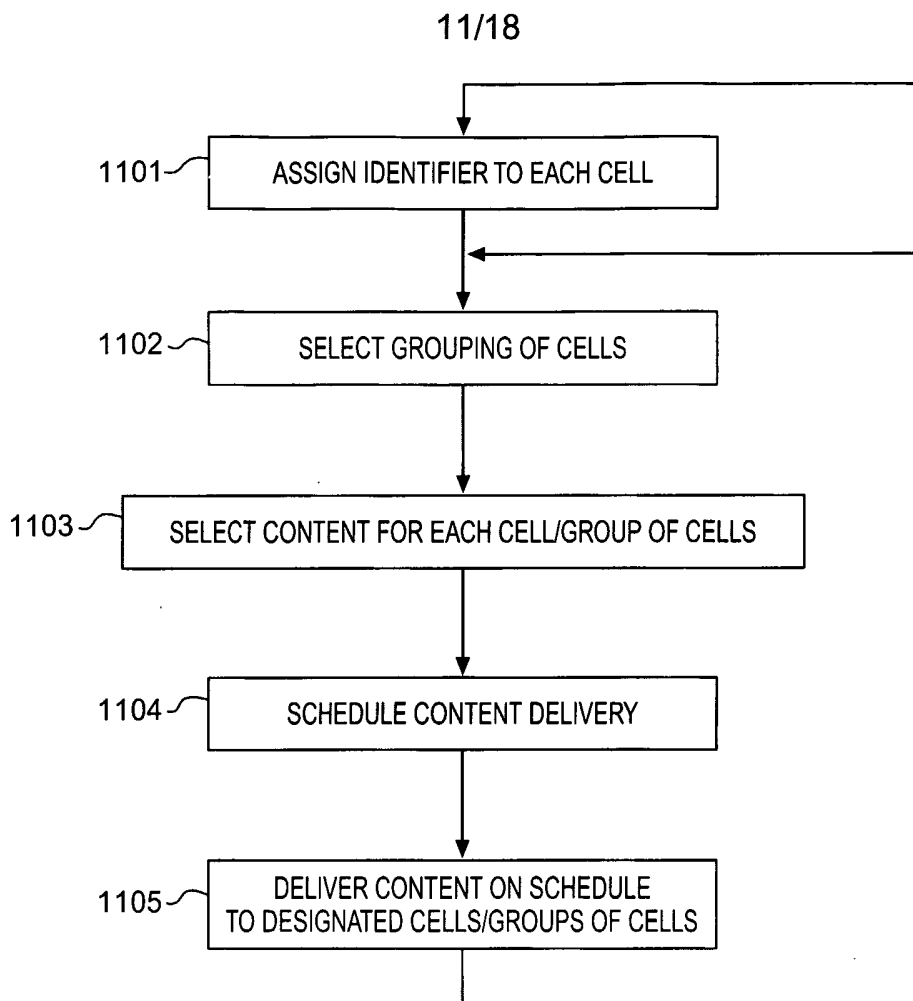

FIG. 11

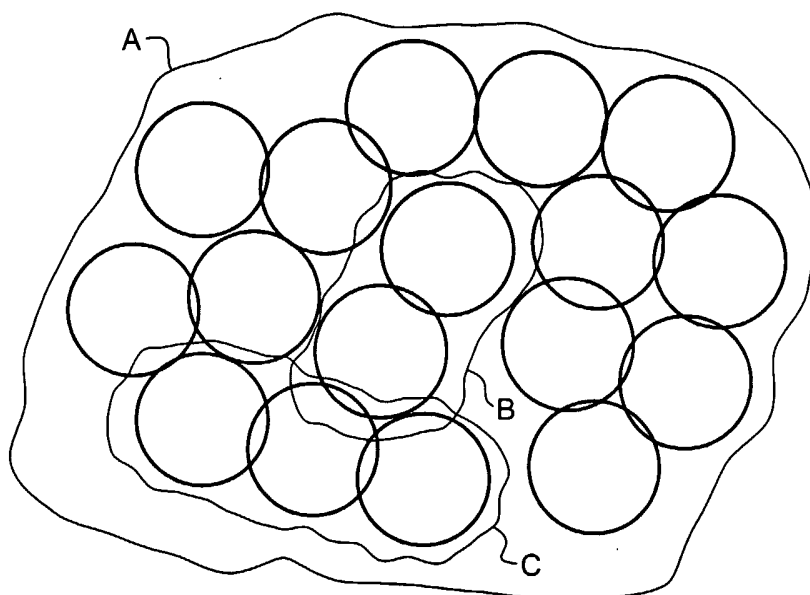

FIG. 12

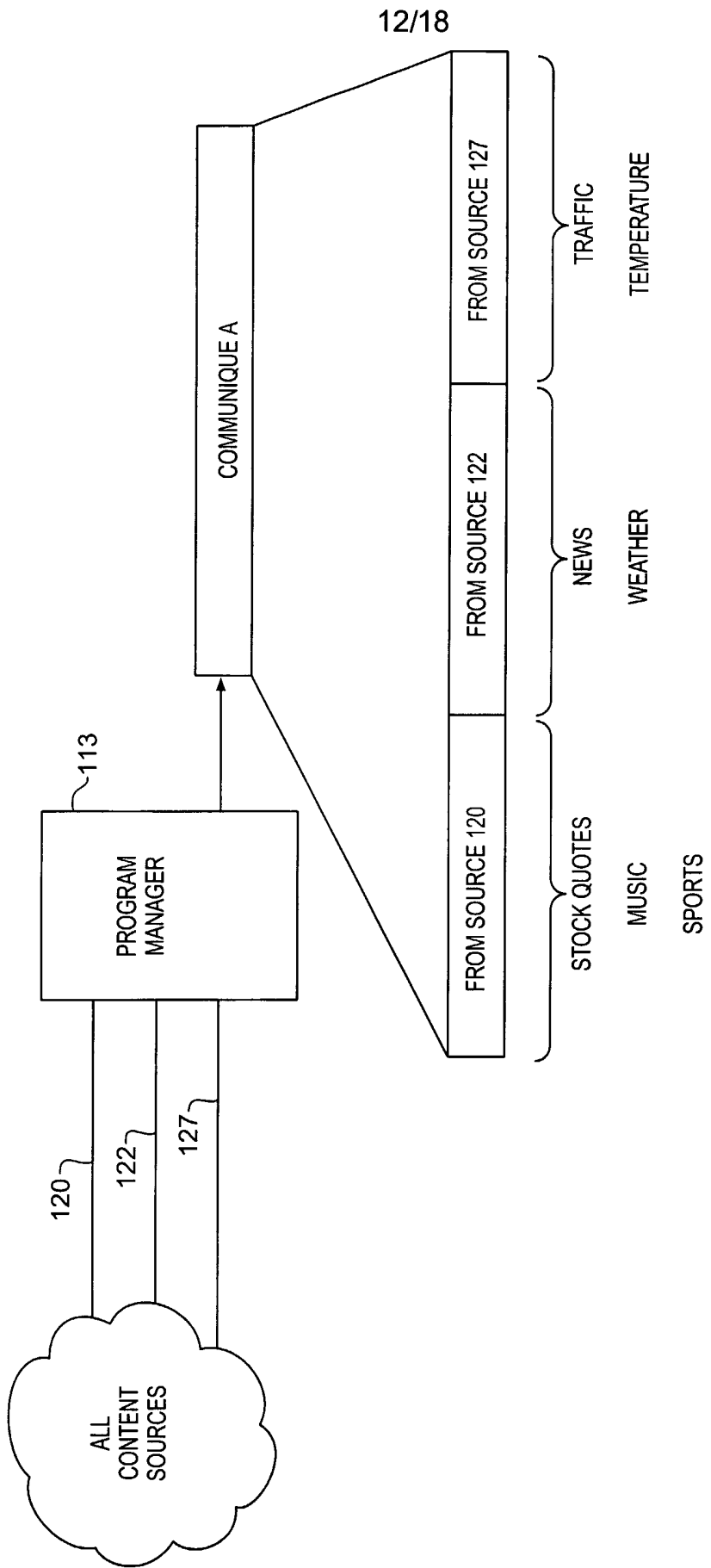

FIG. 13

13/18

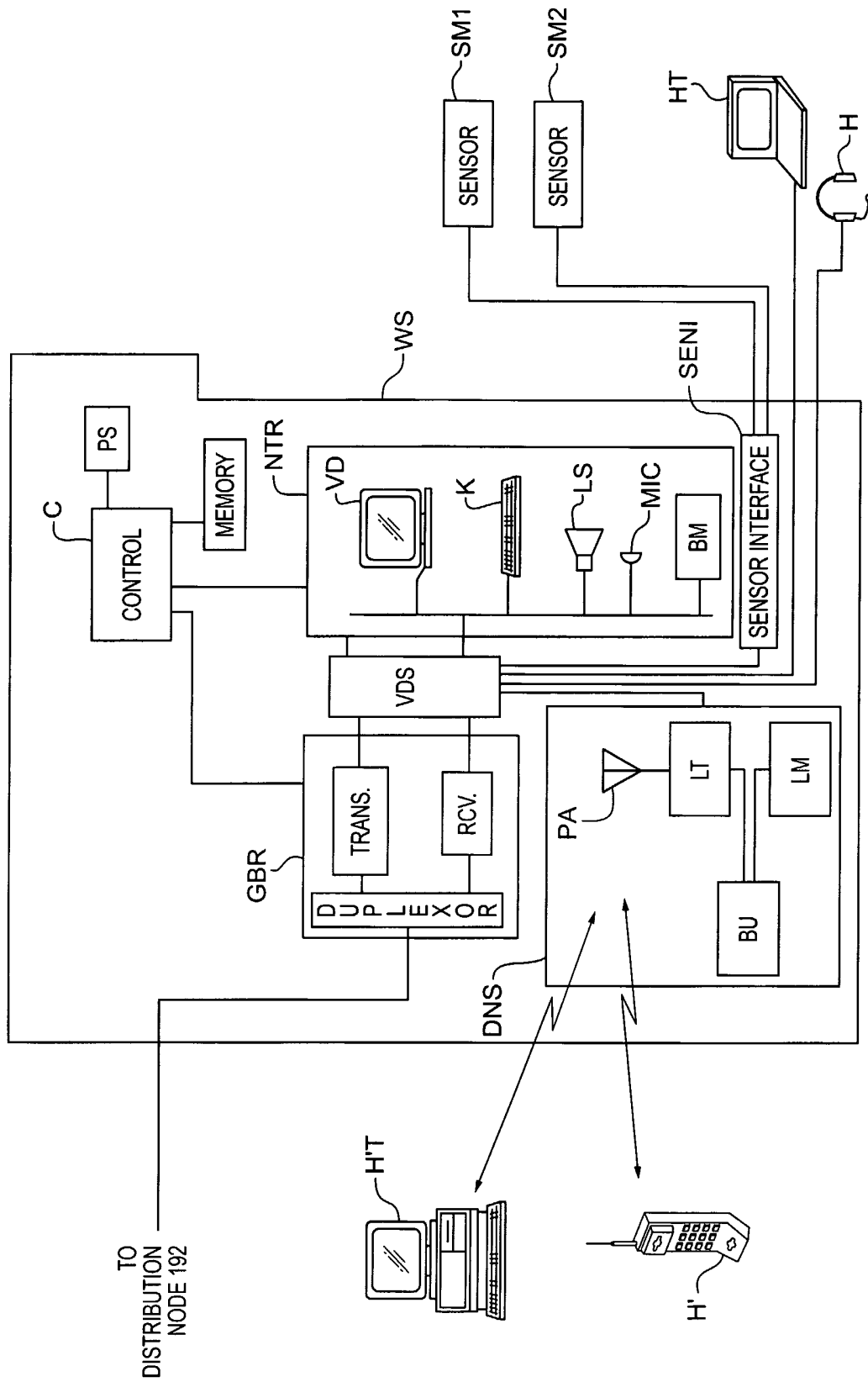

FIG. 14

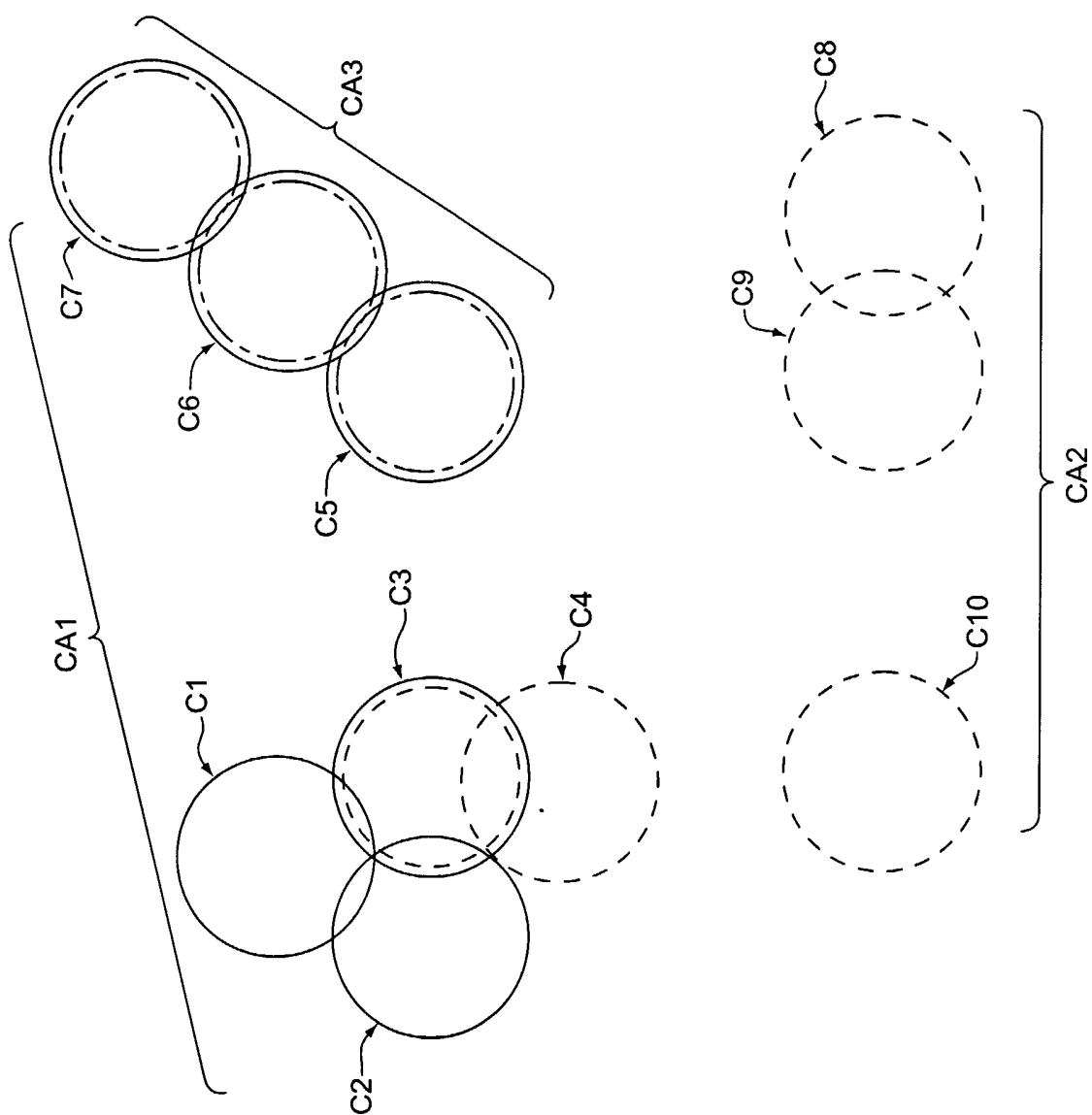

FIG. 15

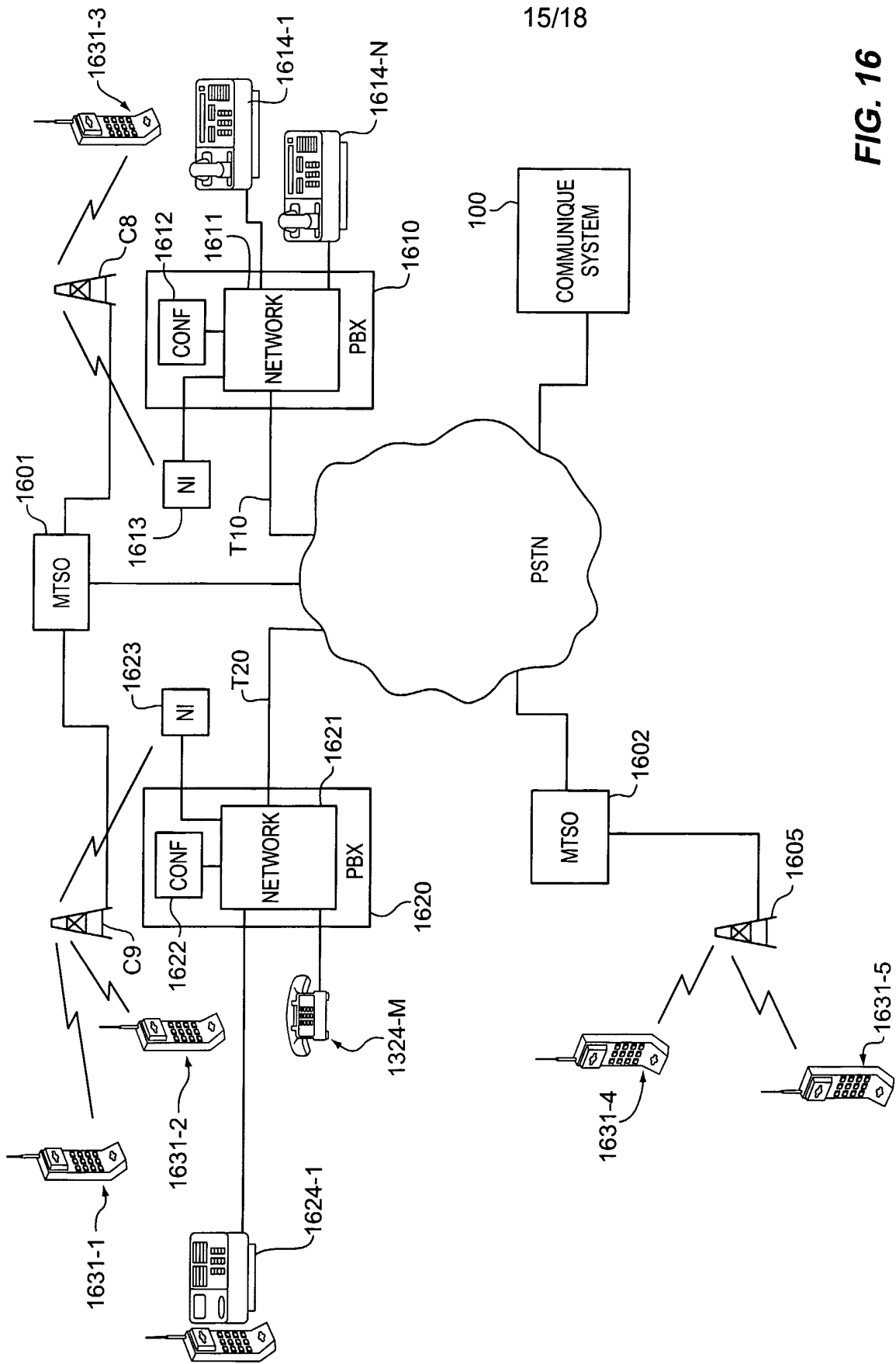
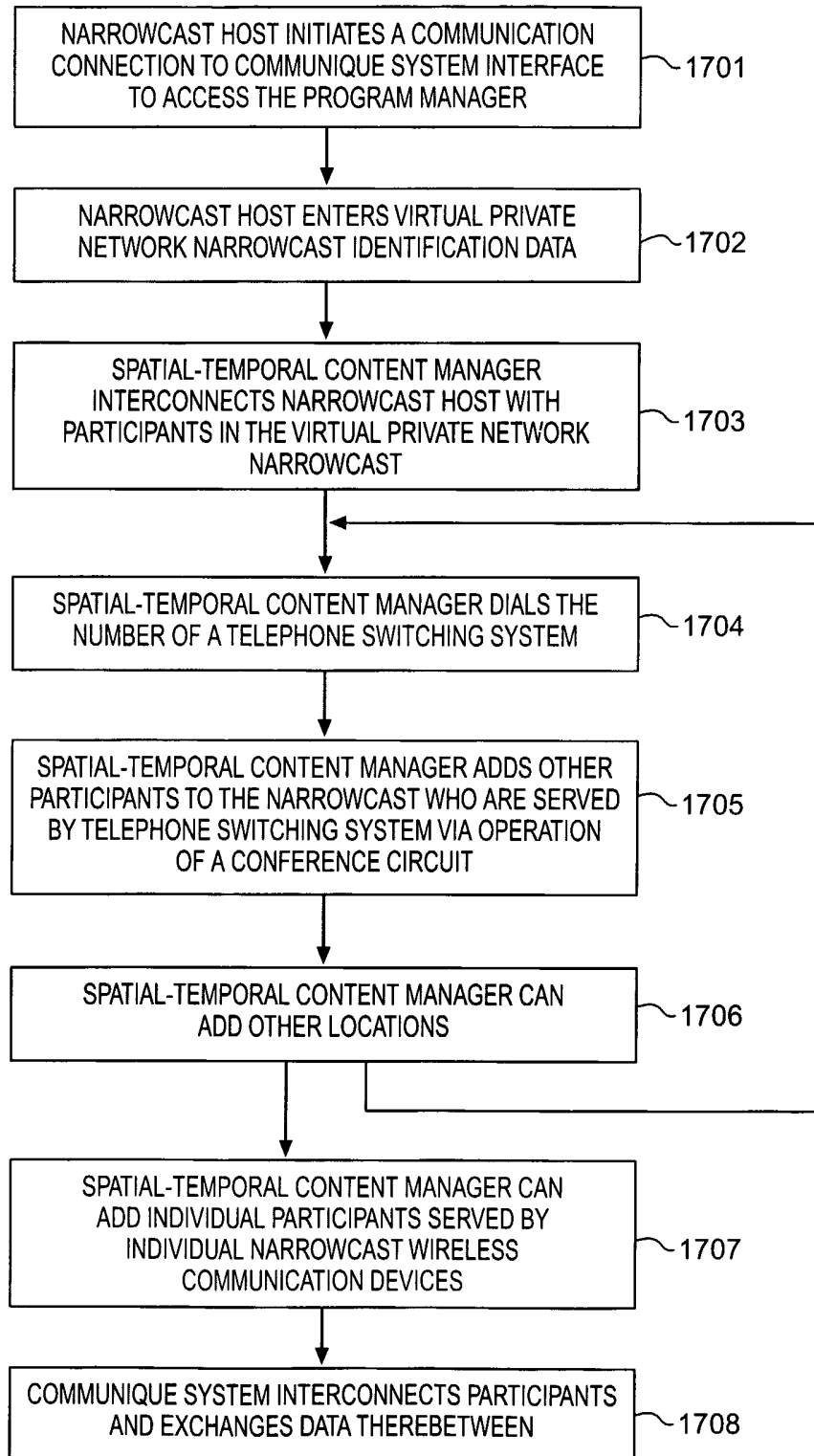

FIG. 16

FIG. 17



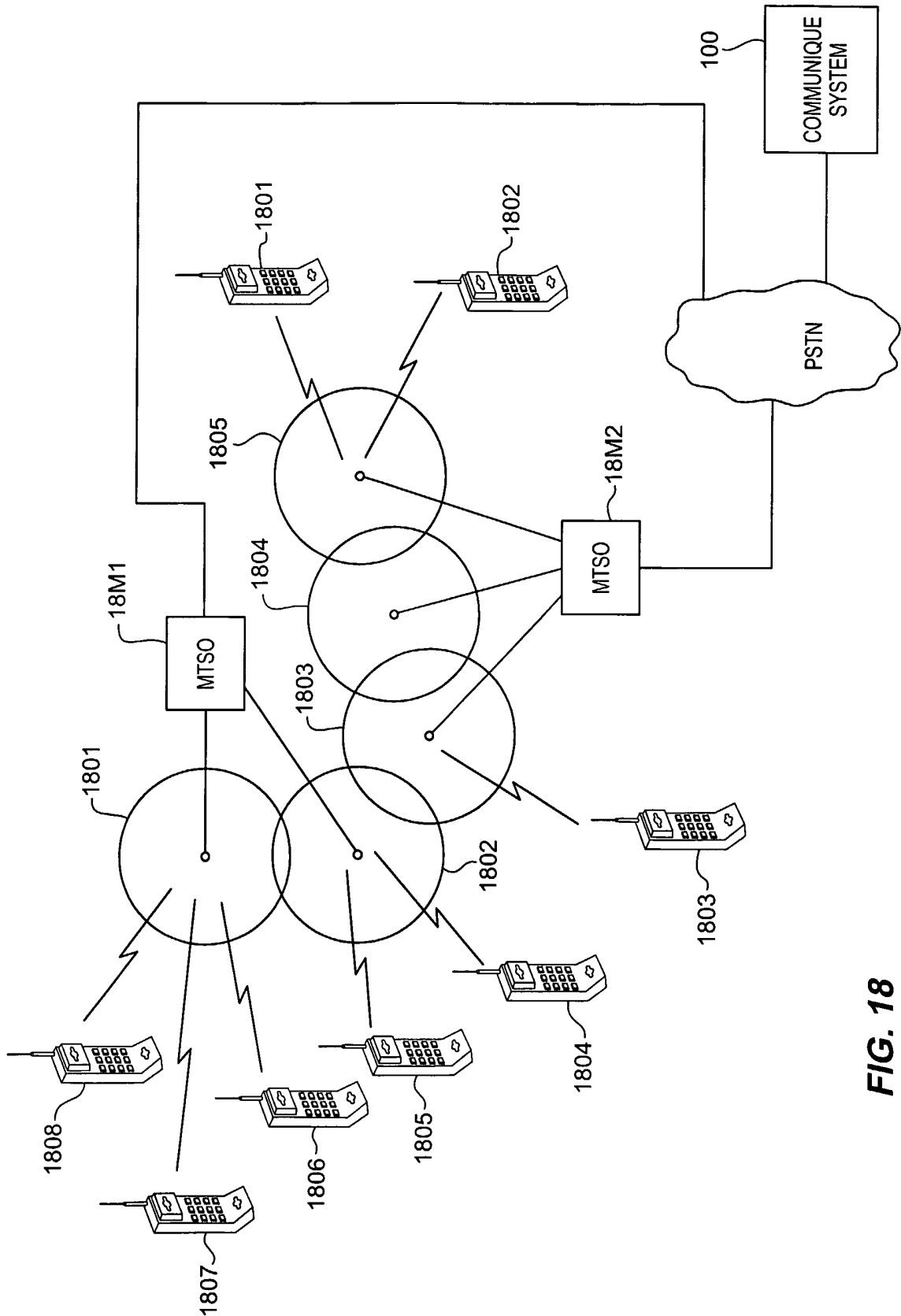

FIG. 18

FIG. 19

