



US00D841981S

(12) **United States Design Patent**  
**Kögel**

(10) **Patent No.:** **US D841,981 S**

(45) **Date of Patent:** **\*\* Mar. 5, 2019**

(54) **TRANSPORT BOX**

D738,106 S \* 9/2015 Shitrit ..... D3/276  
D785,938 S \* 5/2017 Ou ..... D3/282  
D790,221 S \* 6/2017 Yahav ..... D3/294

(71) Applicant: **BS SYSTEMS GMBH & CO. KG,**  
Zusmarshausen (DE)

(Continued)

(72) Inventor: **Jan Kögel,** Zusmarshausen (DE)

*Primary Examiner* — Manpreet S Matharu

*Assistant Examiner* — Holly E Thurman

(73) Assignee: **BS SYSTEMS GMBH & CO. KG,**  
Zusmarshausen (DE)

(74) *Attorney, Agent, or Firm* — Paul D. Bianco; Lourdes Perez; Fleit Gibbons Gutman Bongini & Bianco PL

(\*\*) Term: **15 Years**

(57) **CLAIM**

(21) Appl. No.: **35/503,359**

The ornamental design for a transport box, as shown and described.

(22) Filed: **Jan. 13, 2017**

**DESCRIPTION**

(80) **Hague Agreement Data**

Int. Filing Date: **Jan. 13, 2017**  
Int. Reg. No.: **DM/094369**  
Int. Reg. Date: **Jan. 13, 2017**  
Int. Reg. Pub. Date: **Jul. 14, 2017**

FIG. 2.1 is a front view of a first embodiment of a transport box according to the present invention;

FIG. 2.2 is bottom view thereof;

FIG. 2.3 is a top view thereof;

FIG. 2.4 is a left side view, the right side being a mirror image thereof;

FIG. 2.5 is a back view thereof;

FIG. 2.6 is a perspective view thereof;

(51) **LOC (11) Cl.** ..... **03-01**

(52) **U.S. Cl.**

USPC ..... **D3/282**

FIG. 4.1 is a front view of a second embodiment of a transport box according to the present invention;

FIG. 4.2 is bottom view thereof;

FIG. 4.3 is a top view thereof;

FIG. 4.4 is a left side view, the right side being a mirror image thereof;

FIG. 4.5 is a back view thereof;

FIG. 4.6 is a perspective view thereof;

(58) **Field of Classification Search**

USPC ..... D3/273, 274, 275, 276, 281, 282, 283,  
D3/284, 292, 294, 295, 296, 302, 905,  
D3/900, 901, 903, 205  
CPC ..... A45C 5/04; A45C 11/00; A45C 11/16;  
A45C 15/04

See application file for complete search history.

FIG. 6.1 is a front view of a third embodiment of a transport box according to the present invention;

FIG. 6.2 is bottom view thereof;

FIG. 6.3 is a top view thereof;

FIG. 6.4 is a left side view, the right side being a mirror image thereof;

FIG. 6.5 is a back view thereof; and

FIG. 6.6 is a perspective view thereof.

(56) **References Cited**

**U.S. PATENT DOCUMENTS**

D360,757 S \* 8/1995 Snetting ..... D3/276  
D439,408 S \* 3/2001 Gibson ..... D3/276  
D470,658 S \* 2/2003 Chunn ..... D3/282  
D572,479 S \* 7/2008 Buck ..... D3/282  
D600,015 S \* 9/2009 Wenchel ..... D3/294  
D601,797 S \* 10/2009 Wenchel ..... D3/294  
D608,094 S \* 1/2010 Concari ..... D3/282  
D719,352 S \* 12/2014 Shitrit ..... D3/282

The broken lines shown in the drawings illustrate portions of the transport box that form no part of the claimed design.

**1 Claim, 18 Drawing Sheets**

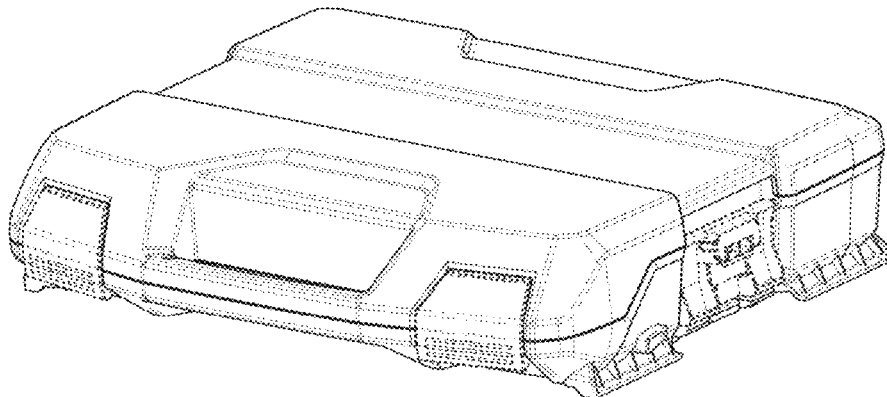

(56)

**References Cited**

U.S. PATENT DOCUMENTS

D801,685 S \* 11/2017 Meng ..... D3/294  
D808,653 S \* 1/2018 Rayeski ..... D3/273

\* cited by examiner

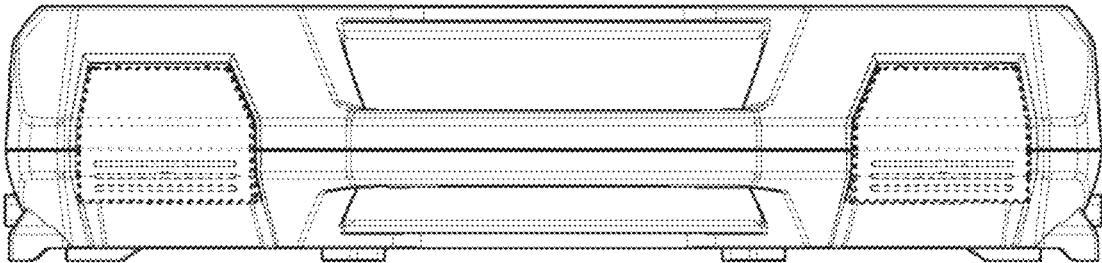

2.1

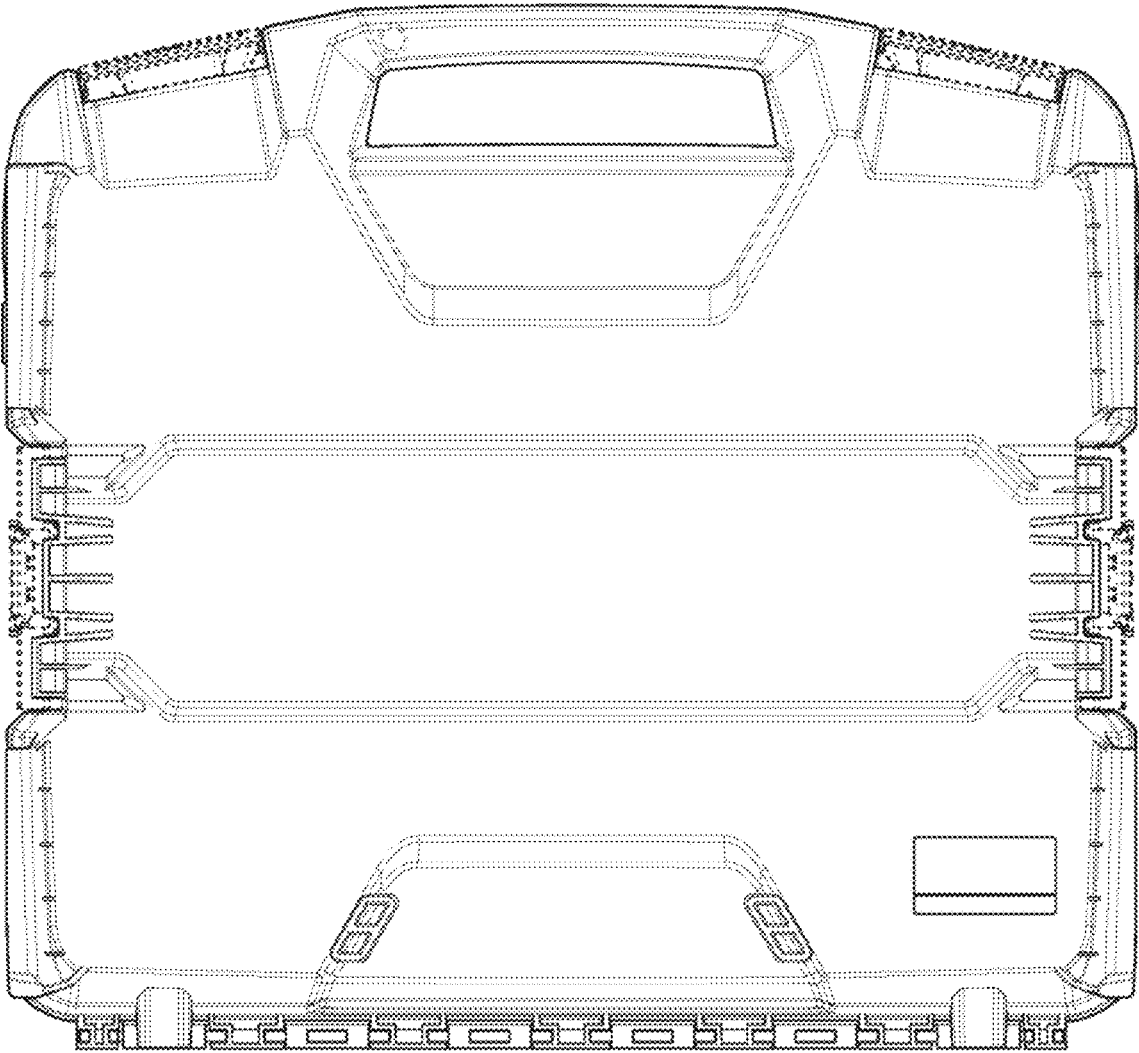

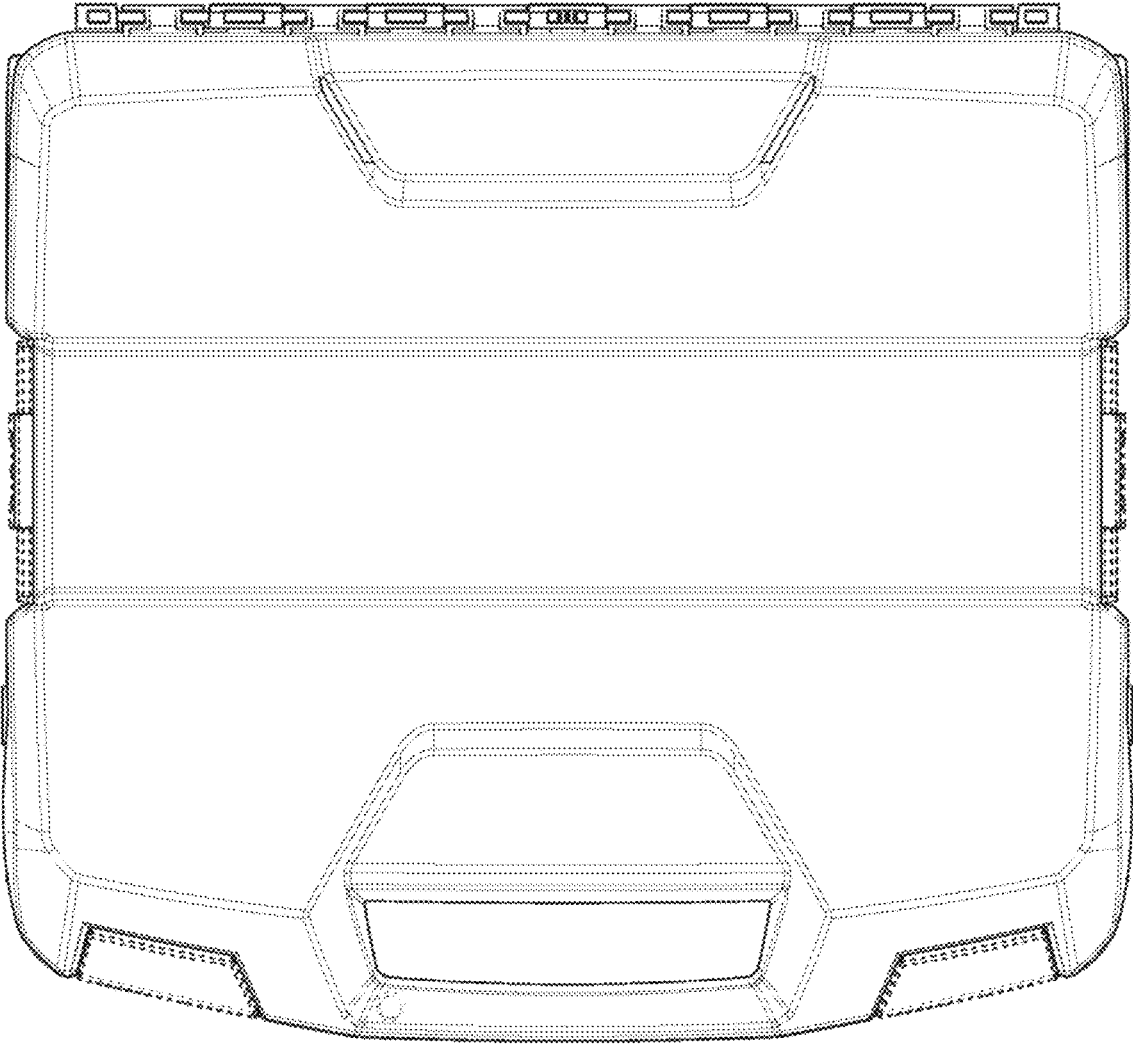

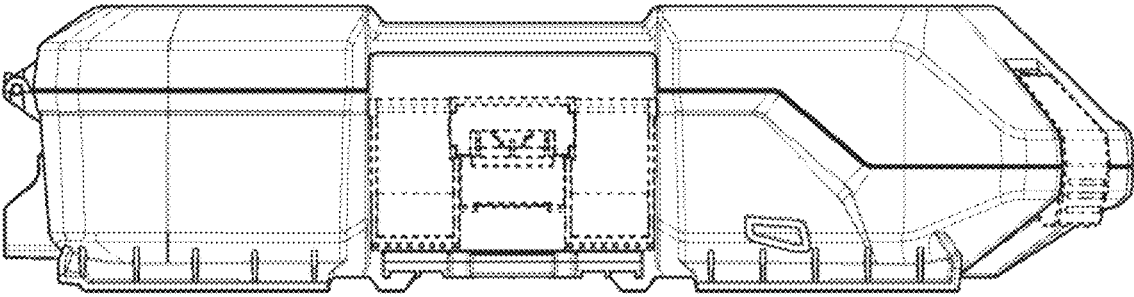

2.4

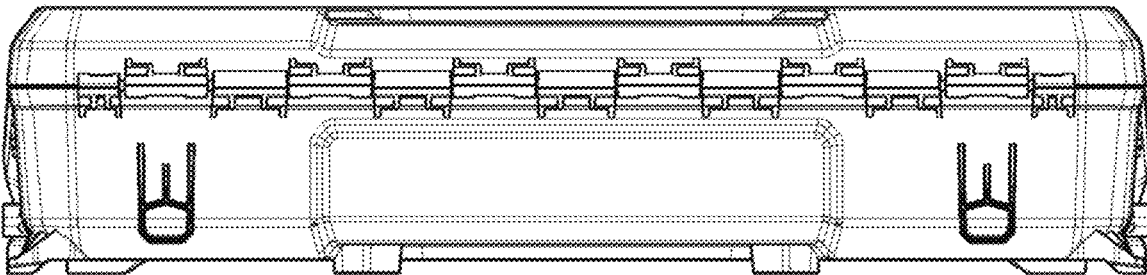

2.5

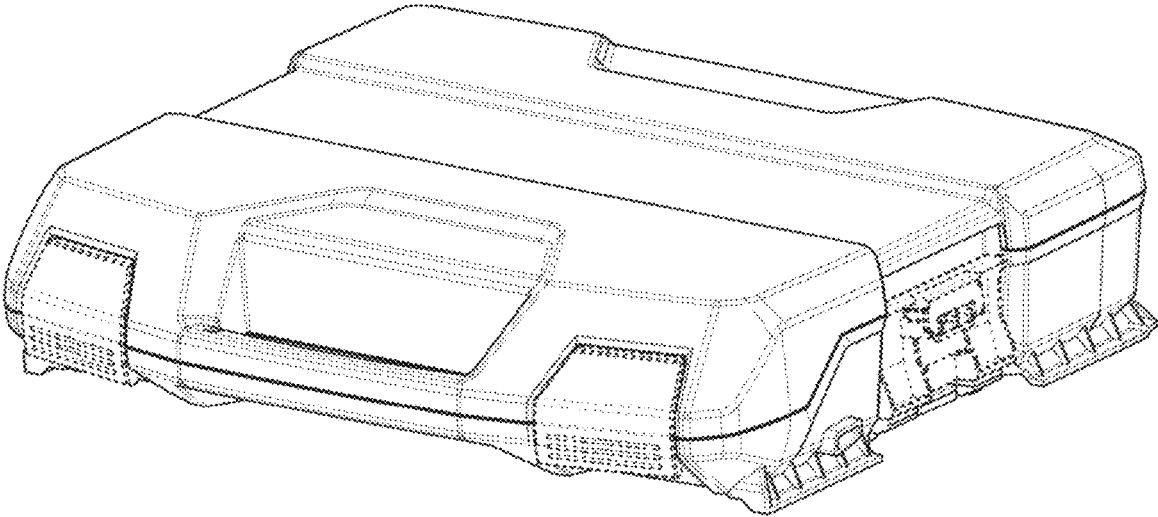

2.6

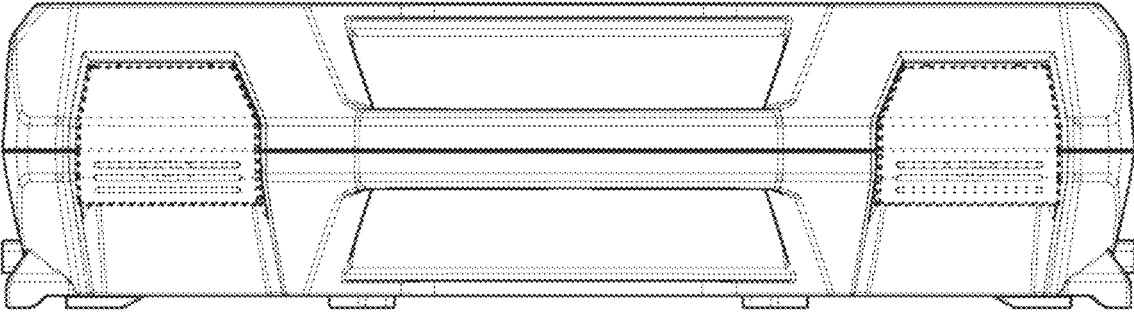

4.1

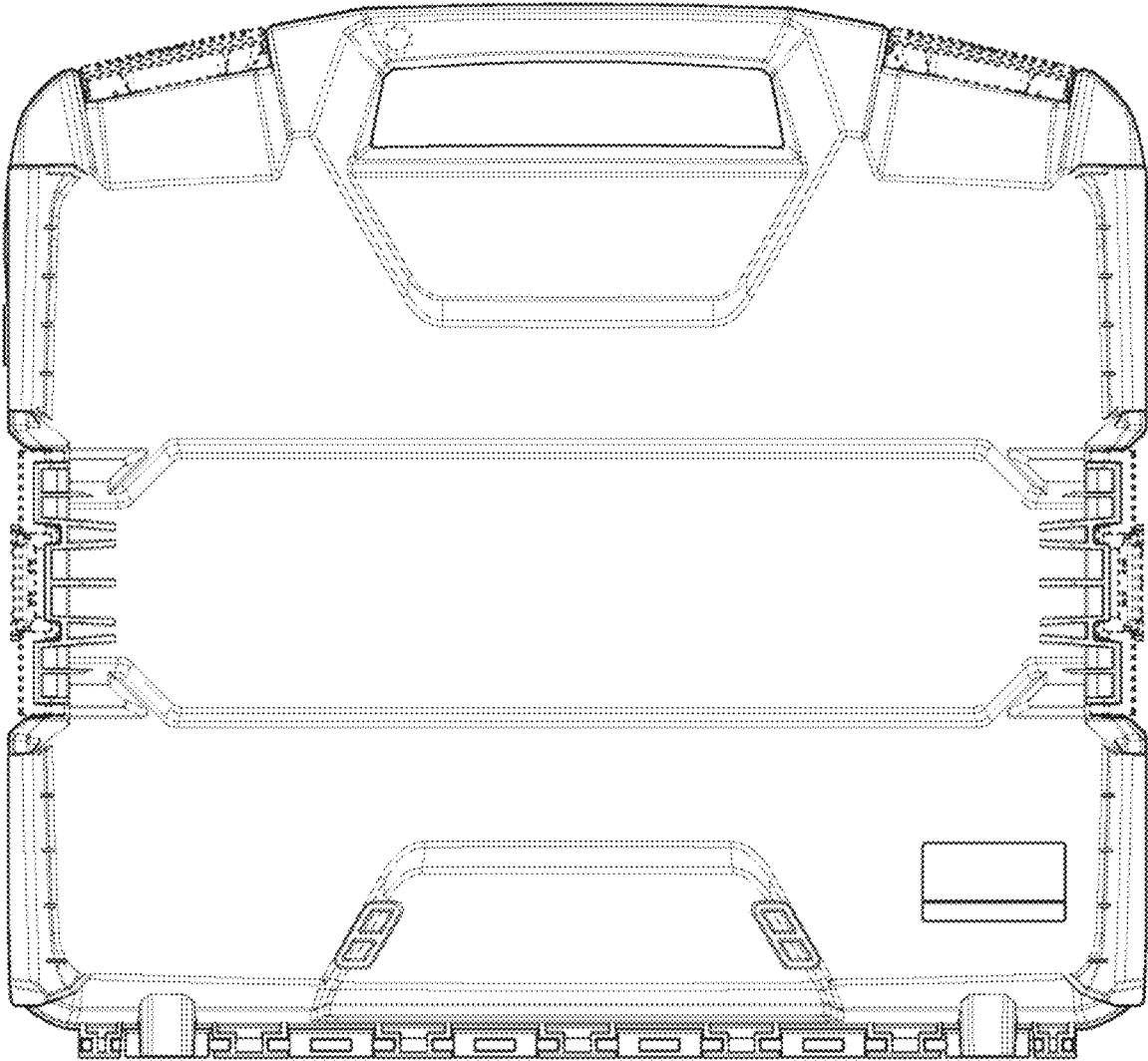

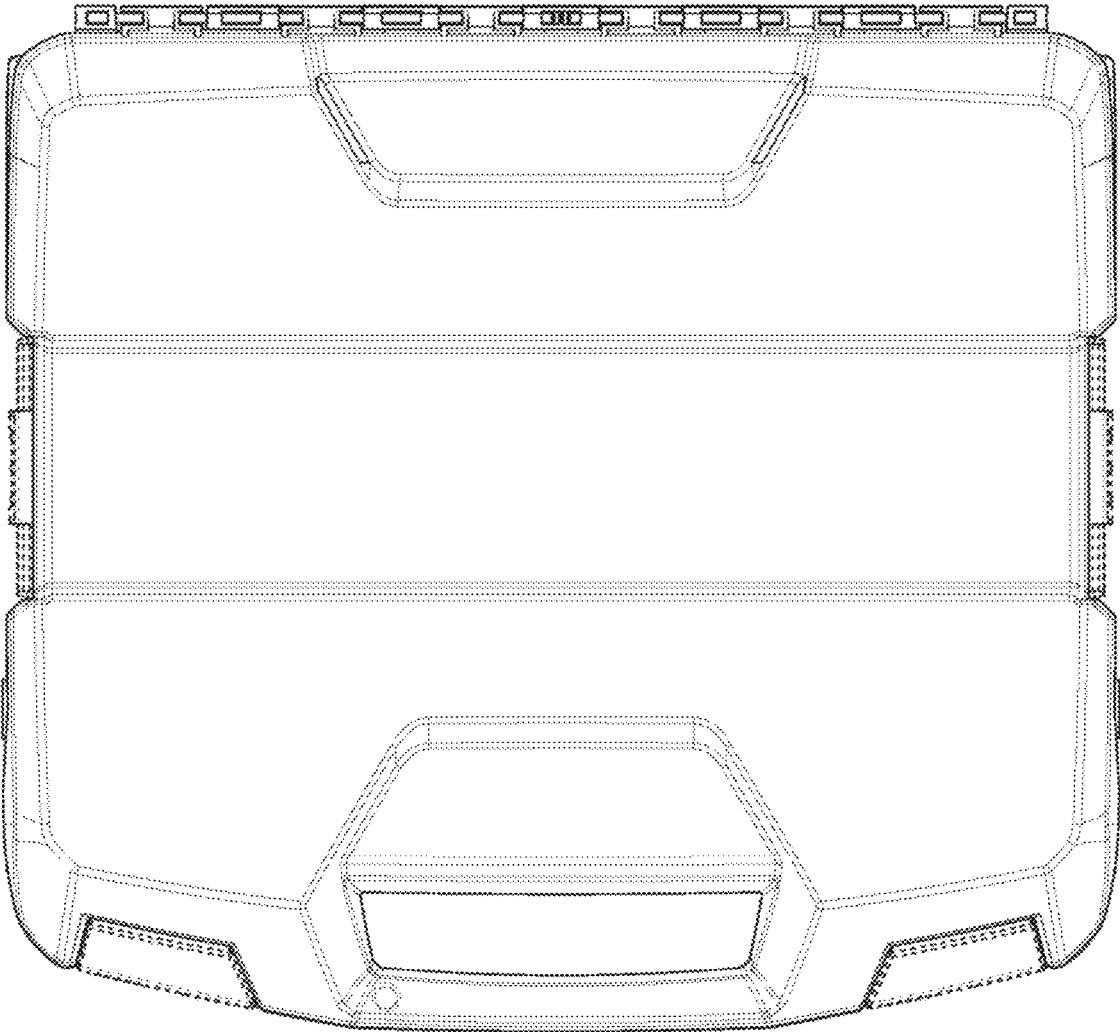

4.3

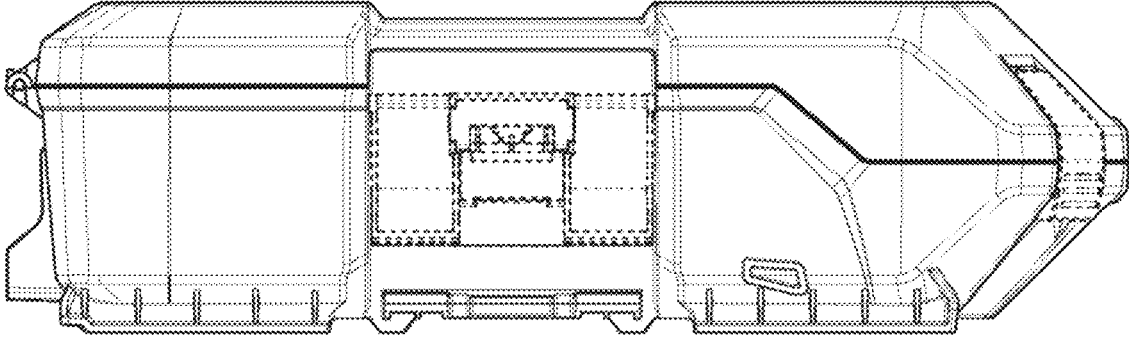

4.4

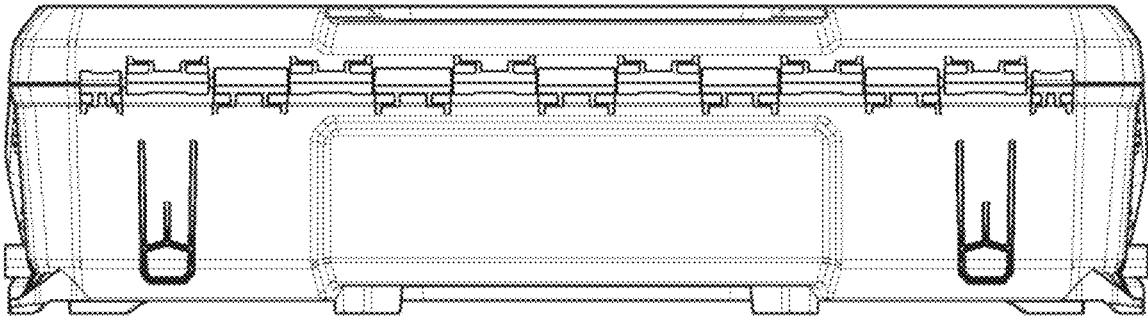

4.5

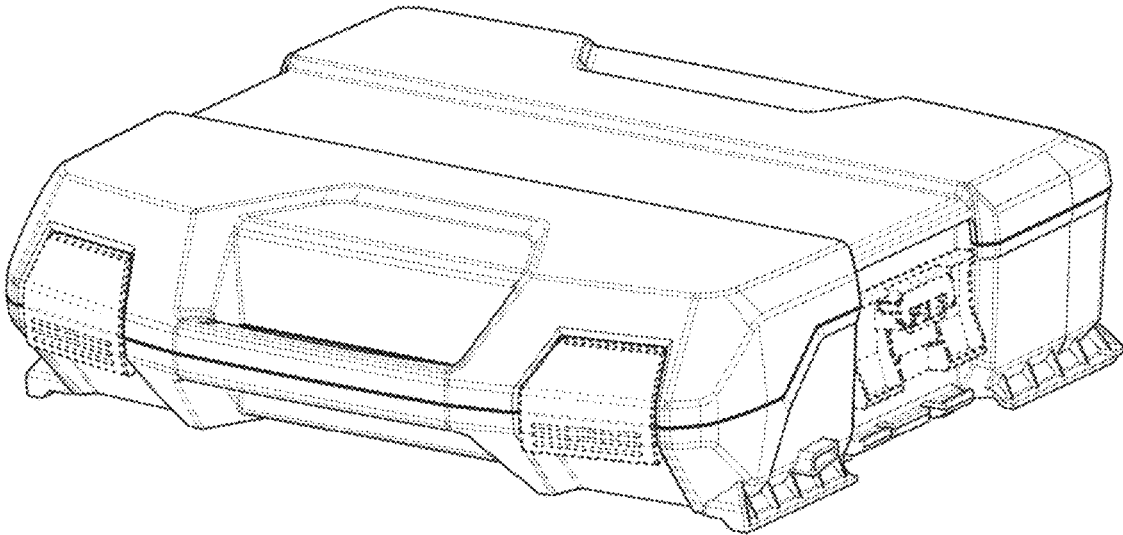

4.6

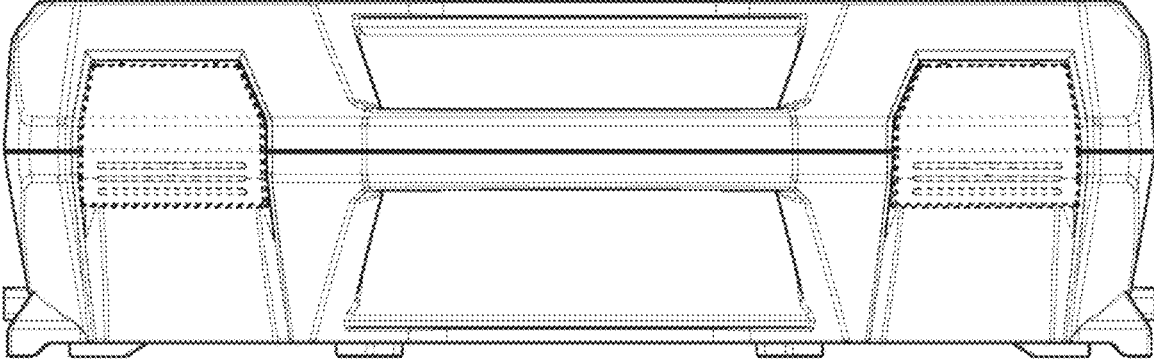

6.1

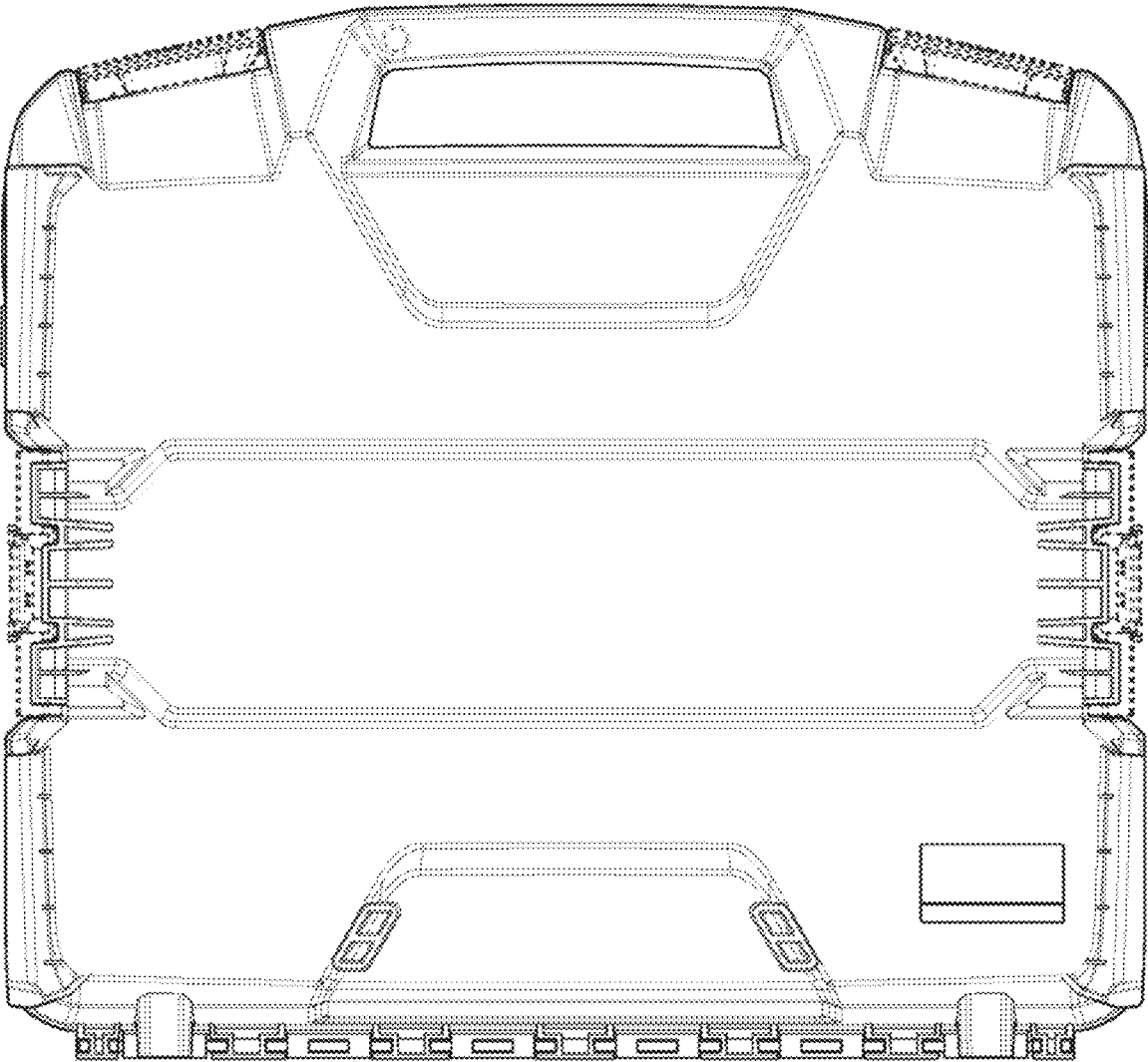

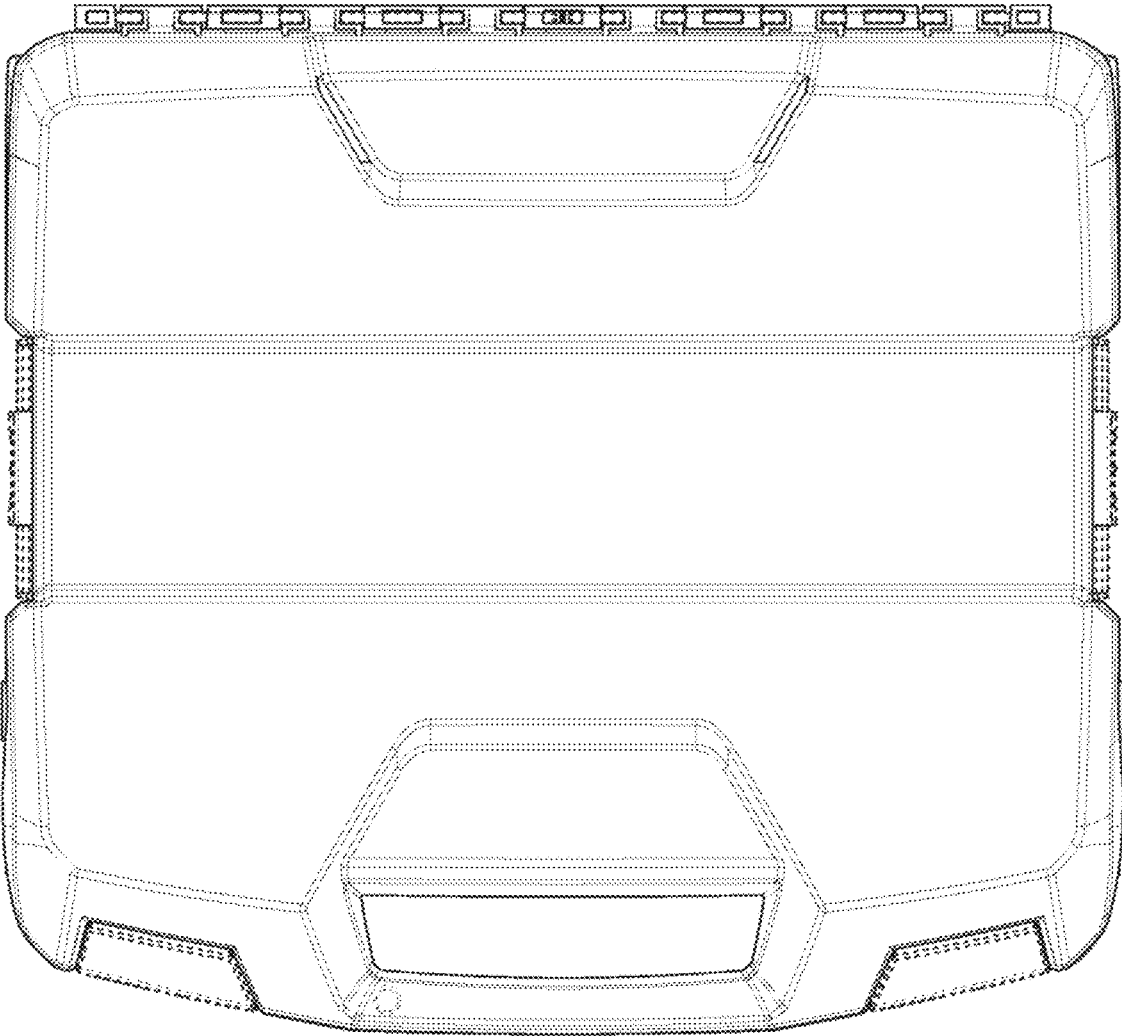

6.3

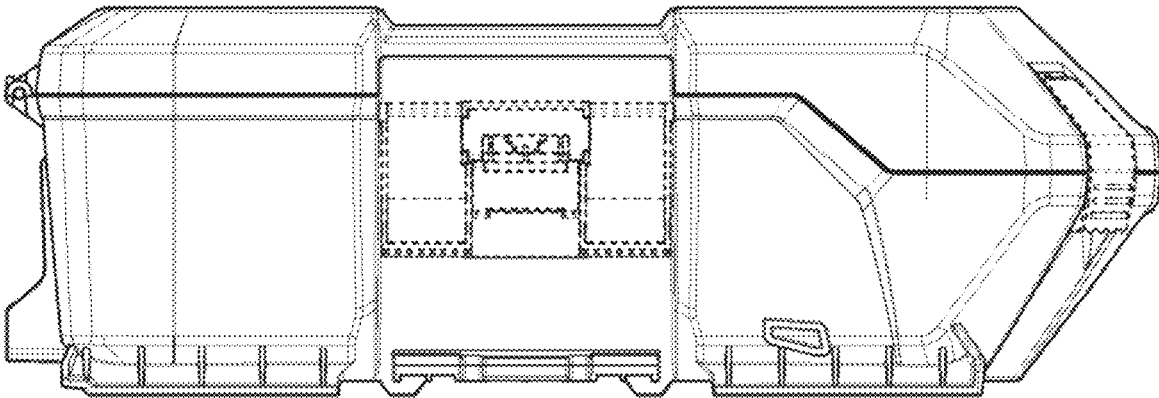

6.4

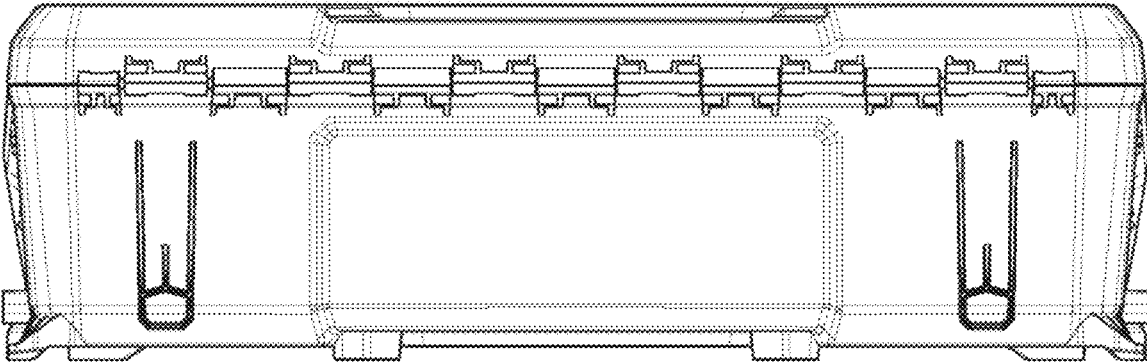

6.5

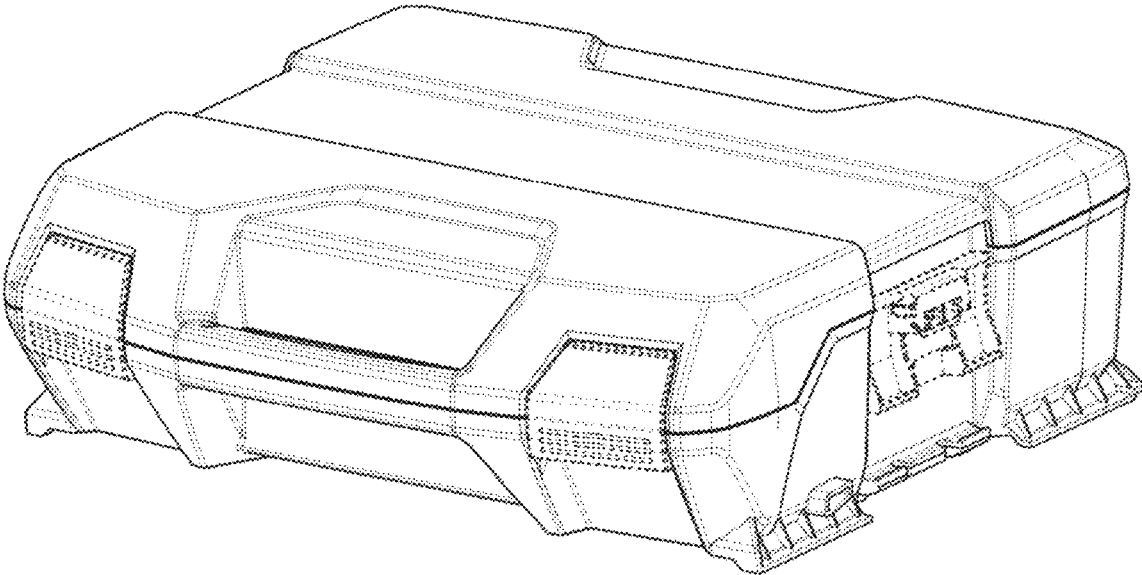

6.6