

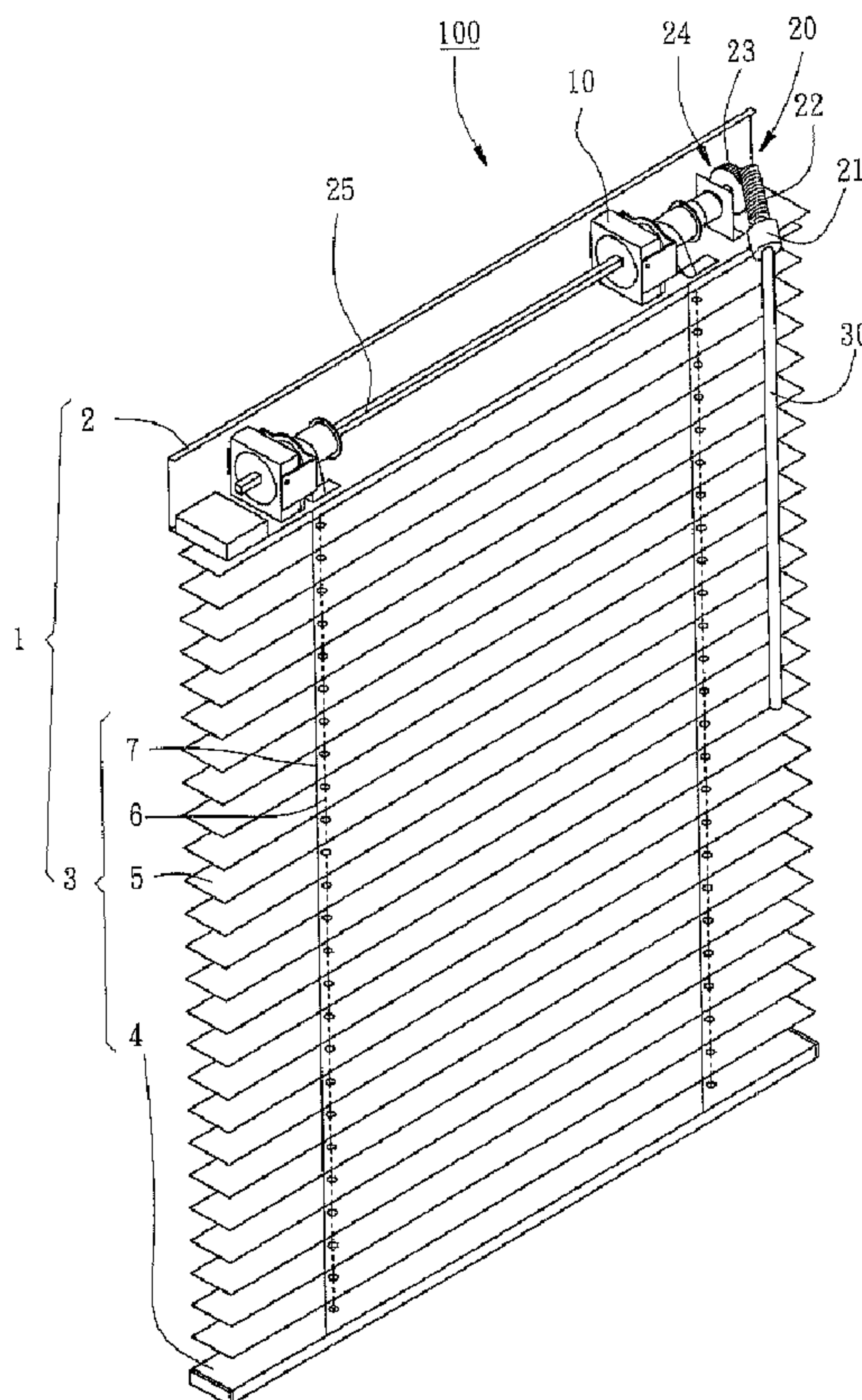

(22) Date de dépôt/Filing Date: 2003/08/08
 (41) Mise à la disp. pub./Open to Public Insp.: 2004/12/27
 (45) Date de délivrance/Issue Date: 2006/12/12
 (30) Priorité/Priority:
 2003/06/27 (Taiwan, Province of China 92211875)

(51) Cl.Int./Int.Cl. *E06B 9/32* (2006.01),
E06B 9/308 (2006.01), *E06B 9/307* (2006.01),
E06B 9/322 (2006.01)
 (72) Inventeur/Inventor:
 NIEN, MING, TW
 (73) Propriétaire/Owner:
 NIEN MADE ENTERPRISE CO., LTD., TW
 (74) Agent: MCFADDEN, FINCHAM

(54) Titre : STRUCTURE DE COMMANDE DE STORE A RESSORT
 (54) Title: WINDOW BLIND CONTROL STRUCTURE



(57) Abrégé/Abstract:

A window blind control structure used in a window blind for controlling lifting and tilting of the blind slats is constructed to include a transmission mechanism mounted in a headrail of the window blind and coupled to blind slats of the window blind, a linking mechanism coupled to the transmission mechanism, and an operation device for operation by the user to bias the linking mechanism and to further drive the transmission mechanism to adjust the elevation and tilting angle of the blind slats.

VENETIAN BLIND CONTROL STRUCTURE

ABSTRACT OF THE DISCLOSURE

A window blind control structure used in a window blind for controlling lifting and tilting of the blind slats is constructed to include a transmission mechanism
5 mounted in a headrail of the window blind and coupled to blind slats of the window blind, a linking mechanism coupled to the transmission mechanism, and an operation device for operation by the user to bias the linking mechanism and to further drive the transmission mechanism to adjust the elevation and tilting angle of the blind slats.

WINDOW BLIND CONTROL STRUCTURE

BACKGROUND OF THE INVENTION

1. Field of the Invention

5 The present invention relates generally to a window blind and, more specifically, to a window blind control structure for use in a window blind to control the elevation and tilting angle of the blind slats.

2. Description of the Related Art

10 A conventional window blind is generally comprised of a headrail fixedly located on the top side of the window, and a blind body suspended from the headrail and controllable by an external force to change its window shading status.

15 Conventional window blinds may have the lift cord and tilt cord exposed to the outside or arranged in a hidden status. A window blind with exposed lift cord and tilt cord has the lift cord and the tilt cord respectively suspended from the left and right ends of the headrail for pulling by the user to adjust the elevation or tilting angle of the blind slats. Because the lift cord and the tilt cord are exposed to the outside and accessible to children, an accident may happen when a child playing with the lift cord or tilt cord for fun.

20 Various window blinds with hidden cord members have been disclosed, and have appeared on the market. There is known a window blind with hidden cord members which uses spring means to keep the blind slats in balance and to hold the blind slats and the bottom rail in position after an adjustment of the window blind by the user. There is known another design of window blind with hidden cord members, which uses the tension force of a positioning cord member to support the bottom rail in
25 position after an adjustment of the window blind by the user. The use of spring means

of positioning cord member cannot eliminate the problem of elastic fatigue. When the problem of elastic fatigue occurred, the spring means or positioning cord member can no longer support the bottom rail accurately in position. There is also known a window blind, which uses an operation rod and a linking mechanism to substitute for a lift cord for blind slats lifting control. A similar design is shown in French Patent Publication No. 2692002. This window blind design eliminates the drawbacks of the aforesaid conventional window blinds with hidden cord members. However, this design is used for controlling the elevation of the blind slats only. It cannot control the tilting angle of the blind slats. For controlling the tilting angle of the blind slats, an additional tilting rod and tilting transmission mechanism should be provided. The arrangement of the additional tilting rod and tilting transmission mechanism greatly complicates the structure of the window blind. Because lifting and tilting of the blind slats are separately controlled, the operation is inconvenient.

15 **SUMMARY OF THE INVENTION**

The present invention has been accomplished under the circumstances in view. It is one feature of a preferred embodiment of the present invention to provide a window blind control structure, which has no cord member exposed to the outside, preventing hanging of exposed cord member on a child accidentally.

20 It is another feature of the present invention to provide a window blind control structure, which, in preferred embodiments, uses one single driving source to control lifting and tilting of the blind slats.

In accordance with one embodiment of the present invention, the window blind control structure is installed in a window blind having a headrail and a

window body formed of a bottom rail and a set of slats and suspended from the headrail. The window blind control structure comprises a transmission mechanism mounted in the headrail of the window blind. The transmission mechanism has an amplitude modulation control device coupled to the blind body for controlling lifting of the blind body, a frequency modulation control device coupled to the blind body for controlling tilting of the blind body, and a clutch coupled to the amplitude modulation control device and the frequency modulation control device for controlling synchronous action between said amplitude modulation control device and said frequency modulation control device. A linking mechanism is mounted in the headrail and coupled to the transmission mechanism, having an input member adapted to receive an external biasing force, and an actuating member coupled between the input member and the transmission mechanism and adapted to drive the transmission mechanism upon action of the input member. An operation device is coupled to the input member of the linking mechanism for operation by the user to rotate the input member.

The at least one amplitude modulation control device each comprises an amplitude control wheel. The at least one clutch each comprises a holder base. The holder base has a recessed hole formed in one side thereof and is adapted to accommodate the amplitude control wheel of one of the at least one amplitude modulation control device.

The at least one frequency modulation control device each comprises a frequency control wheel. The frequency control wheel comprises a circular through hole, which receives one amplitude control wheel of the at least one amplitude modulation control device. The at least one clutch each further

comprises a limiter affixed to the holder base of the corresponding clutch and is adapted to stop the corresponding frequency control wheel from falling out of the corresponding amplitude control wheel.

The amplitude control wheel has a longitudinal slot formed in the periphery of one end thereof inside the holder base of one of the at least one clutch. The at last one frequency modulation control device each comprises a frequency control wheel. The frequency control wheel has a groove. The at least one clutch each further comprises a spring member mounted in the slot of the amplitude control wheel and stopped at one end thereof with the slot. A link is mounted in the slot of the amplitude control wheel and supported on the other end of the spring member and is engageable into the groove of the frequency control wheel of the corresponding frequency modulation control device being mounted on the corresponding amplitude control wheel for enabling the corresponding frequency control wheel to be synchronously rotated with the corresponding amplitude control wheel.

The at least one clutch each further comprises a stop block affixed to one side of the corresponding holder base around the recessed hole of the corresponding holder base. The stop block has a smoothly arched notch formed in a top side thereof and fits the periphery of the recessed hole of the corresponding holder base, and two sloping faces respectively downwardly extended from two sides of the smoothly arched notch toward the recessed hole of the corresponding holder base and adapted to force the corresponding link away from the corresponding frequency control wheel after rotation of the frequency control wheel of each of said at least one frequency modulation control

device with the amplitude control wheel of each of said at least one amplitude modulation control device through a predetermined angle.

In accordance with another embodiment of the present invention there is provided a window blind control structure adapted to be installed in a window blind having a headrail and a window body suspended from the headrail. The window blind control structure comprises a transmission mechanism mounted in the headrail of the window blind. The transmission mechanism has at least one amplitude modulation control device coupled to the window body for controlling lifting of the blind body. At least one frequency modulation control device is coupled to the window body for controlling tilting of the window body, and at least one clutch is coupled to the amplitude modulation control device and the frequency modulation control device for controlling synchronous action between the amplitude modulation control device and the frequency modulation control device. A linking mechanism is mounted in the headrail and coupled to the transmission mechanism, the linking mechanism has an input member adapted to receive an external biasing force, and an actuating member coupled between the input member and the transmission mechanism and adapted to drive the transmission mechanism upon action of the input member. An operation device is coupled to the input member of the linking mechanism for operation by the user to bias the input member. The at least one amplitude modulation control device each comprises an amplitude control wheel. The amplitude control wheel has an outer thread extended around the periphery thereof, the at least one clutch each comprises a holder base. The holder base has an axially extended center through hole and an inner thread extended around the periphery of the axially extended

center through hole and threaded onto the outer thread of the amplitude control wheel of one of the at least one amplitude modulation control device for enabling the corresponding amplitude control wheel to be rotated forwards and backwards relative to the corresponding holder base.

5 Yet another embodiment of the present invention provides a window blind control structure adapted to be installed in a window blind having a headrail and a window body suspended from the headrail. The window blind control structure comprises a transmission mechanism mounted in the headrail of the window blind. The transmission mechanism has at least one amplitude modulation control
10 device coupled to the window body for controlling lifting of the blind body. The at least one frequency modulation control device is coupled to the window body for controlling tilting of the window body. The at least one clutch is coupled to the amplitude modulation control device and the frequency modulation control device for controlling synchronous action between the amplitude modulation control
15 device and the frequency modulation control device. A linking mechanism is mounted in the headrail and coupled to the transmission mechanism. The linking mechanism has an input member adapted to receive an external biasing force, and an actuating member coupled between the input member and the transmission mechanism and adapted to drive the transmission mechanism upon
20 action of the input member. An operation device is coupled to the input member of the linking mechanism for operation by the user to bias the input member. The at least one amplitude modulation control device each comprises an amplitude control wheel. The amplitude control wheel comprising a wheel shaft coupled to the linking mechanism, the wheel shaft has a key hole in the periphery thereof, a

bobbin sleeved onto the wheel shaft, the bobbin has a first axial center hole extended to one end thereof, a second axial center hole extended to an opposite end thereof in communication and line with the first axial center hole. The second axial center hole has a diameter greater than the first axial center hole, and an
5 inside projection suspended in the second axial center hole and disposed in contact with the periphery of the wheel shaft. A key is mounted in the key hole of the wheel shaft and partially protruded over the periphery of the wheel shaft and adapted to stop and push the inside projection of the bobbin and to further rotate the bobbin upon rotary motion of the wheel shaft.

10 A still further embodiment of the present invention provides a window blind control structure adapted to be installed in a window blind having a headrail and a window body suspended from the headrail. The window blind control structure comprises a transmission mechanism mounted in the headrail of the window blind, the transmission mechanism has at least one amplitude modulation control
15 device coupled to the window body for controlling lifting of the blind body. At least one frequency modulation control device is coupled to the window body for controlling tilting of the window body. At least one clutch is coupled to the amplitude modulation control device and the frequency modulation control device for controlling synchronous action between the amplitude modulation control
20 device and the frequency modulation control device. A linking mechanism is mounted in the headrail and coupled to the transmission mechanism. The linking mechanism has an input member adapted to receive an external biasing force, and an actuating member coupled between the input member and the transmission mechanism and adapted to drive said transmission mechanism upon

action of said input member. An operation device is coupled to the input member of the linking mechanism for operation by the user to bias the input member. The linking mechanism further comprises self-locking means, which allows the input device to bias the actuating member but prohibits the actuating member from
5 biasing the input member.

BRIEF DESCRIPTION OF THE DRAWINGS

FIG. 1 illustrates a window blind control structure installed in a window blind according to a first preferred embodiment of the present invention.

FIG. 2 is an exploded view of one symmetrical half of the transmission
10 mechanism of the window blind control structure according to the first preferred embodiment of the present invention.

FIG. 3 is an assembly view of FIG. 2.

FIG. 4 is a sectional view in an enlarged scale of a part of FIG. 1, showing the structure of the transmission mechanism.

15 FIG. 5 is a schematic plain view in an enlarged scale of a part of FIG. 1, showing the lift cord wound round the tail of the corresponding amplitude control

20

25

3e

wheel.

FIG. 6 and FIG. 7 are schematic plain views of a part of the transmission mechanism of the window blind control structure according to the first preferred embodiment of the present invention, showing the relative motion among the amplitude (lift cord) modulation control device, the frequency (ladder tape) modulation control device, and the corresponding clutch.

FIG. 8 and FIG. 9 are schematic sectional end views of a part of the transmission mechanism of the window blind control structure according to the first preferred embodiment of the present invention, showing the relative motion among the amplitude (lift cord) modulation control device, the frequency (ladder tape) modulation control device, and the corresponding clutch.

FIG. 10 illustrates a window blind control structure installed in a window blind according to a second preferred embodiment of the present invention.

FIG. 11 is an exploded view of one symmetrical half of the transmission mechanism of the window blind control structure according to the second preferred embodiment of the present invention.

FIG. 12 is an assembly view of FIG. 11.

FIG. 13 is a sectional side view in an enlarged scale of a part of FIG. 10, showing the structure of the transmission mechanism.

FIG. 14 is a schematic plain view in an enlarged scale of a part of FIG. 10, showing the lift cord wound round the tail of the corresponding amplitude control wheel.

FIG. 15 illustrates a window blind control structure installed in a window blind according to a third preferred embodiment of the present invention.

FIG. 16 is an exploded view of one symmetrical half of the transmission

mechanism of the window blind control structure according to the third preferred embodiment of the present invention.

FIG. 17 is an assembly view of FIG. 16.

FIG. 18 is a sectional side view of the assembly shown in FIG. 17.

5 FIG. 19 is a sectional end of the assembly shown in FIG. 17, showing the amplitude control wheel rotated in clockwise direction.

FIG. 20 is similar to FIG. 19 but showing the amplitude control wheel rotated in counter-clockwise direction.

DETAILED DESCRIPTION OF THE INVENTION

10 Referring to FIG. 1, a window blind control structure **100** is used in a window blind **1**. The window blind **1** comprises a headrail **2**, and a blind body **3**. The headrail **2** is transversely (horizontally) affixed to the top side of the window (not shown). The blind body **3** comprising a bottom rail **4** suspended below the headrail **2**, a set of slats **5** transversely (horizontally) arranged in parallel between the headrail **2** and
 15 the bottom rail **4**, two lift cords **6** bilaterally longitudinally (vertically) extended through the slats **5**, and two ladder tapes **7** bilaterally longitudinally extended over the slats **5** and the bottom rail **4** to join the slats **5** and the bottom rail **4**. Each lift cord **6** has a bottom end affixed to the bottom rail **4** and a top end extended to the inside of the headrail **2**. Each ladder tape **7** has two distal ends extended to the inside of the headrail
 20 **2**. The lift cords **6** are adapted to control the elevation of the bottom rail **4**. The ladder tapes **7** are adapted to control the tilting angle of the slats **5**.

Referring to FIG. 1 again, the control structure **100** comprises a transmission mechanism **10** mounted in the headrail **2** of the window blind **1**, a linking mechanism **20** mounted in the headrail **2** and coupled to the transmission mechanism **10**, and an
 25 operation device **30** coupled to the linking mechanism **20** for operation by the user.

Referring to FIG. 1 again, the linking mechanism 20 comprises a rod-like input member 21 rotatably and substantially vertically pivoted to the right end inside the headrail 2 of the window blind 1 and partially extended out of the bottom side of the headrail 2, a double-thread worm 22 fixedly connected to the top side of the input member 21, an actuating member 24 formed of a worm gear 23 and meshed with the double-thread worm 22, and a rod member 25 of non-circular cross-section axially extended from the center of the worm gear 23 for synchronous rotation with the worm gear 23 and horizontally suspended inside the headrail 2 in parallel to the slats 5.

Referring to FIGS. 2 and 3 and FIG. 1 again, the transmission mechanism 10 comprises two amplitude (lift cord) modulation control devices 11, two frequency (ladder tape) modulation control devices 13, and two clutches 15. The amplitude modulation control devices 11, the frequency modulation control devices 13, and the clutches 15 are respectively bilaterally mounted inside the headrail 2 corresponding to the lift cords 6 and the ladder tapes 7.

Each amplitude (lift cord) modulation control device 11 comprises an amplitude control wheel 12. The amplitude control wheel 12 is a stepped cylindrical member, having a head 122 disposed at one end, a tail 125 disposed at the other end, a body 123 axially disposed between the head 122 and the tail 125, the body 123 having an outer diameter smaller than the head 122 but greater than the tail 125, a conical portion 124 connected between the body 123 and the tail 125 corresponding to one lift cord 6 and sloping in direction from the body 123 toward the tail 125, an axial center through hole 121 of non-circular cross-section axially extended through the center of the head 122, the body 123, the conical portion 124 and the tail 125 and adapted to receive the rod member 25 for synchronous rotation with the rod member 25, a longitudinal slot 126 axially extended from the body 123 into the head 122, and a

retaining portion 127 located on the free end of the tail 125 for the connection of the top end of one lift cord 6 (see FIG. 3).

Each frequency (ladder tape) modulation control device 13 comprises a frequency control wheel 14. The frequency control wheel 14 comprises a body 141, a head 142 connected to one end of the body 141, a groove 143 inwardly extended from the free end of the body 141, a circular through hole 144 axially extended through the body 141 and the head 142. By means of the circular through hole 144, the frequency control wheel 14 is sleeved onto the body 123 of the amplitude control wheel 12, keeping the body 141 of the frequency control wheel 14 abutted against the head 122 of the amplitude control wheel 12. The two ends of the ladder tapes 7 are respectively fastened to respective retaining portions 145 at the heads 142 of the frequency control wheels 14 of the corresponding frequency (ladder tape) modulation control device 13 (see FIGS. 2 and 3).

Each clutch 15 is comprised of a holder base 151, a spring member 152, a stop block 153, a link 154, and a limiter 155. The holder base 151 is fixedly mounted in the headrail 2, having a circular center through hole 151a and a circular recessed hole 151b in one side around the center through hole 151a. The diameter of the circular center through hole 151a is smaller than the outer diameter of the head 122 of the amplitude control wheel 12. The diameter of the circular recessed hole 151b is not less than the outer diameter of the head 122 of the amplitude control wheel 12 so that the head 122 of the amplitude control wheel 12 can be inserted into the circular recessed hole 151b and stopped outside the circular center through hole 151a. The spring member 152 is mounted in the slot 126 of the amplitude control wheel 12, and stopped at inner end of the slot 126. The stop block 153 is affixed to the corresponding holder base 151 adjacent to the circular recessed hole 151b, having a smoothly arched

notch **153a** fitting the periphery of the circular recessed hole **151b**, and two sloping faces **153b** and **153c** respectively downwardly extended from the top at two sides of the smoothly arched notch **153a** toward the circular recessed hole **151b** of the corresponding holder base **151**. The link **154** is mounted in the slot **126** of the amplitude control wheel **12** and supported on the other end of the spring member **152**. The spring member **152** imparts an outward pressure to the link **154**, thereby causing the link **154** to engage into the groove **143** of the frequency control wheel **14**. Normally, the link **154** has one part engaged into the slot **126** and the other part engaged into the groove **143**, for enabling the frequency control wheel **14** to be rotated with the amplitude control wheel **12** synchronously. The limiter **155** is mounted on the holder base **151** for preventing escape of the frequency control wheel **14** from the amplitude control wheel **12**.

The operation device **30** is a rod member downwardly extended from the input member **21** to a certain distance for operation by the user. The operation device **30** may be formed integral with the bottom side of the input member **21**. Alternatively, the operation device **30** can be made having a coupling device at the top for coupling to a matching coupling device at the bottom side of the input member.

After detailed description of the structure and relative positioning of the parts of the control structure **100**, the operation of the present invention is outlined hereinafter.

With respect to amplitude control (lifting control):

When receiving the slats **5**, rotate the operation device **30** with the hand to drive the input member **21** to rotate the double-thread worm **22**, the worm gear **23** and the rod member **25** in one direction, thereby causing the amplitude control wheels **12** of the amplitude (lift cord) modulation control devices **11** of the transmission

mechanism **10** to roll up the lift cords **6** (see FIG. 5). When rotating the amplitude control wheels **12** to roll up the lift cords **6**, the lift cords **6** are wound round the conical portions **124** of the respective amplitude control wheels **12**, and then extended around the periphery of the tails **125** of the respective amplitude control wheels **12**
5 smoothly in a good order, and therefore the bottom rail **4** is lifted and the slats **5** are received with the lifting bottom rail **4** to the desired elevation.

The links **154** of the clutches **15** are respectively coupled between the respective amplitude control wheels **12** and the respective frequency control wheels **14** at the initial state during the amplitude control mode. Therefore, during the initial stage
10 of the rotary motion of the amplitude control wheels **12** the frequency control wheels **14** are rotated with the amplitude control wheels **12** to roll up the ladder tapes **7** and to further tilt the slats **5**. When the link **154** of each clutch **15** touched one sloping face **153b** of the stop block **153** of respective clutch **15** during rotary motion of the frequency control wheels **14** with the respective amplitude control wheels **12** (see
15 FIGS. 6 and 8), the link **154** of each clutch **15** is forced to move along the sloping face **153b** of the corresponding stop block **153** into the circular recessed hole **151b** of the corresponding holder base **151** to compress the corresponding spring member **152**, and therefore the link **154** of each clutch **15** is disengaged from the groove **143** of the corresponding frequency control wheel **14** (see FIG. 7) to separate the connection
20 between the frequency control wheel **14** and the corresponding amplitude control wheel **12**. After disconnection of the frequency control wheel **14** of each frequency (ladder tape) modulation control device **13** from the amplitude control wheel **12** of the corresponding amplitude modulation control device **12**, the frequency control wheels **14** of the frequency (ladder tape) modulation control devices **13** are not rotated with
25 the amplitude control wheels **12** of the amplitude (lift cord) modulation control devices

11, and the amplitude control wheels 12 of the amplitude (lift cord) modulation control devices 11 are continuously rotated to roll up the lift cords 6 and to further receive the slats 5.

When opening (extending out) the slats 5 of the blind body 3, rotate the operation device 30 in the reversed directions (reversed to the slat receiving operation) to rotate the double-thread worm 22, the worm gear 23 and the rod member 25 in the reversed direction, thereby causing the amplitude control wheels 12 of the amplitude (lift cord) modulation control devices 11 of the transmission mechanism 10 to let off the lift cords 6, and therefore the bottom rail 4 and the slats 5 are lowered to the desired elevation.

At the initial stage of the rotary motion of the amplitude control wheels 12, the frequency control wheels 14 are separated from the amplitude control wheels 12 due to the effect of the sloping faces 153b of the stop blocks 153 of the clutches 15. When the links 154 carried by the corresponding amplitude control wheels 12 to the position in line with the grooves 143 of the corresponding frequency control wheels 14, the respective spring members 152 immediately force the links 154 into the grooves 143 of the corresponding frequency control wheels 14, thereby causing the frequency control wheels 14 to be linked to the respective amplitude control wheels 12 by the respective links 154 for synchronous rotation. When the links 154 moved with the corresponding amplitude control wheels 12 from the sloping faces 153b of the respective stop blocks 153 to the sloping faces 153c, the links 154 are forced away from the grooves 143 of the respective frequency control wheels 14 to disconnect the frequency control wheels 14 from the respective amplitude control wheels 12, enabling the amplitude control wheels 12 to be continuously rotated to let off the lift cords 6 and to further open the slats 5.

With respect to frequency control (slat tilting control):

At first, rotate the control device 30 with the hand to further rotate the amplitude control wheels 12 of the amplitude modulation control devices 11 of the transmission mechanism 10. Because the links 154 are respectively coupled between
5 the amplitude control wheels 12 and the frequency control wheels 14 at this time, rotating the amplitude control wheels 12 cause the frequency control wheels 14 to roll up the ladder tapes 7 and to further tilt the slats 5. Because it is not necessary to tilt the slats 5 through a wide angle during operation, the synchronous rotation of the amplitude control wheels and the frequency control wheels 14 can be controlled within
10 a predetermined range (about 180°). When tilted the slats 5 to the desired tilted position, stop the rotation of the operation device 30, keeping the slats 5 in the adjusted tilted position (during the aforesaid operation procedure, the amount of vertical displacement of the bottom rail 4 following rotary motion of the amplitude control wheels 12 is quite small and does not affect the reliability of the operation).

15 According to the above statement, the control structure 100 has numerous advantages as outlined hereinafter.

Because the invention uses a rod-like operation device to control lifting and tilting of the slats, the lift cords are hidden in the window body, preventing hanging of exposed cord members on a child accidentally.

20 Because the invention uses one operation device to control lifting and tilting of the slats, the control of the window blind is easy (one single operation source), and the exposed parts are minimized (conventional tilting rod is eliminated). Because the invention eliminates the conventional split type frequency control mechanism, the control structure requires less installation.

25 Further, when receiving the slats, the gravity weight of the bottom rail and

the slats may reverse the amplitude modulation control devices and frequency modulation control devices. The invention eliminates this problem. According to the present invention, the linking mechanism works as self-locking means to automatically lock the slats in position after each operation of the operation device, i.e., the worm
5 can be driven to rotate the worm gear; however the worm gear cannot be driven to rotate the worm (the worm and worm gear form a force multiplier). An additional self-locking device may be used to lock the linking mechanism after each operation of the operation device in case the bottom rail and the slats are excessively heavy. This self-locking device is operated manually by the user. It enhances the security of the
10 window blind. Because this self-locking device is a common device available on the market, no further detailed description in this regard is necessary.

FIGS. 10~14 show a window blind control structure **200** according to a second preferred embodiment of the present invention. According to this second embodiment, the window blind **1**, the linking mechanism **20**, and the operation device
15 **30** are identical to like parts in the aforesaid first preferred embodiment of the present invention; however the transmission mechanism **40** is different from the transmission mechanism of the aforesaid first embodiment of the present invention.

The transmission mechanism **40** comprises two amplitude (lift cord) modulation control devices **41**, two frequency (ladder tape) modulation control devices
20 **43**, and two clutches **45**. The amplitude modulation control devices **41**, the frequency modulation control devices **43**, and the clutches **45** are respectively bilaterally mounted inside the headrail **2** corresponding to the lift cords **6** and the ladder tapes **7**.

Each amplitude (lift cord) modulation control device **41** comprises an amplitude control wheel **42**. The amplitude control wheel **42** is a cylindrical member
25 having an axial center through hole **423** of non-circular cross-section axially extended

through the two distal ends, an outer thread **421** extended around the periphery, and a longitudinal sliding groove **422** longitudinally extended in the periphery and cut through the outer thread **421**.

Each clutch **45** is comprised of a holder base **451**, a spring member **452**, a pressure ring **453**, a stop block **454**, a link **455**, and a limiter **456**. The holder base **451** has a circular center through hole **451a**, a circular recessed hole **451b** in one side around the center through hole **451a**, and an inner thread **451c** extended around the periphery of the center through hole **451a** and threaded onto the outer thread **421** of the corresponding amplitude control wheel **42**. The spring member **452** is a coil spring sleeved onto the corresponding amplitude control wheel **42** and received in the circular recessed hole **451b** of the corresponding holder base **451**, having one end stopped at the step between the circular recessed hole **451b** and center through hole **451a** in the corresponding holder base **451** and the other end stopped at the corresponding pressure ring **453**. The pressure ring **453** is sleeved onto the corresponding amplitude control wheel **42** and supported on the spring member **452**. The stop block **454** is affixed to the corresponding holder base **451**, having a smoothly arched notch **454a** fitting the periphery of the circular recessed hole **451b** of the corresponding holder base **451**, and two sloping faces **453b** and **453c** respectively downwardly extended from the top at two sides of the smoothly arched notch **453a** toward the circular recessed hole **451b** of the corresponding holder base **451**. The link **455** is a substantially L-shaped key member mounted in the longitudinal sliding groove **422** of the corresponding amplitude control wheel **42**. Each frequency (ladder tape) modulation control **43** comprises a frequency control wheel **44**. The structure of the frequency control wheel **44** is similar to the frequency control wheel of the aforesaid first embodiment of the present invention. By means of the circular through hole **444**, the frequency control

wheel **44** is sleeved onto the corresponding amplitude control wheel **42**, for enabling the corresponding link **455** to partially engage into the longitudinal sliding groove **422** of the corresponding amplitude control wheel **42** and partially engage into the groove **443** of the corresponding frequency control wheel **44** to couple the corresponding frequency control wheel **44** to the corresponding amplitude control wheel **42** for synchronous rotation. The limiter **456** is affixed to the corresponding holder base **451** to stop the corresponding frequency control wheel **44** from falling out of the amplitude control wheel **42**.

Therefore, the link **455** can be coupled between the corresponding amplitude control wheel **42** and the corresponding frequency control wheel **44**, or forced by the sloping faces **454b** and **454c** of the corresponding stop block **454** to separate the amplitude control wheel **42** from the frequency control wheel **44**. Therefore, this embodiment enables the user to lift/lower the slats and to tilt the slats by means of a common driving source (control device). Because the amplitude control wheel **42** is fastened to the corresponding holder base **451** through a screw joint, the amplitude control wheel **42** can be rotated forwards/backwards relative to the corresponding holder base **451** to roll up the corresponding lift cord **6**, keeping the corresponding lift cord **6** wound round the outer thread **421** smoothly in a good order (see FIG. 14).

FIGS. 15~20 show a window blind control structure **300** according to a third preferred embodiment of the present invention. According to this third embodiment, the window blind **1**, the linking mechanism **20**, and the operation device **30** are identical to like parts in the aforesaid first and second embodiments of the present invention; however the transmission mechanism **50** is different from the transmission mechanism of the aforesaid first or second embodiment of the present invention.

According to this embodiment, the transmission mechanism **50** is comprised

of two amplitude (lift cord) modulation control devices **51**, frequency (ladder tape) modulation control devices **53**, and two clutches **55**. The amplitude modulation control devices **51**, the frequency modulation control devices **53**, and the clutches **55** are respectively bilaterally mounted inside the headrail **2** corresponding to the lift cords **6** and the ladder tapes **7**.

Each amplitude (lift cord) modulation control device **51** comprises an amplitude control wheel **52**. The amplitude control wheel **52** is comprised of a wheel shaft **521**, a bobbin **522**, and a key **523**. The wheel shaft **521** comprises a mounting portion **521b** at one end, a bearing portion **521d** at the other end, an annular stop flange **521c** extended around the periphery between the mounting portion **521b** and the bearing portion **521d**, an axial center through hole **521a** of non-circular cross-section axially extended through the mounting portion **521b** and the bearing portion **521d**, and a key hole **521e** formed in the bearing portion **521d** adjacent to the annular stop flange **521c** and adapted to accommodate the key **523**. The bobbin **522** is sleeved onto the bearing portion **521d** of the wheel shaft **521**, comprising a first axial center hole **522a** extended to one end and fitting the outer diameter of the bearing portion **521d** of the wheel shaft **521**, a second axial center hole **522b** extended to the other end in communication and line with the first axial center hole **522a**, the second axial center hole **522b** having a diameter greater than the outer diameter of the bearing portion **521d** of the wheel shaft **521**, an inside projection **522c** suspended in the second axial center hole **522b** and disposed in contact with the periphery of the bearing portion **521d** of the wheel shaft **521**, and a tapered face **522d** extended around the periphery of one end of the bobbin **522**. The key **523** is mounted in the key hole **521e** of the wheel shaft **521**, and partially protruded over the periphery of the bearing portion **521d** of the wheel shaft **521**. The lift cords **6** have the respective top ends respectively fastened to

the bobbins **522** of the amplitude control wheels **52** of the amplitude (lift cord) modulation control devices **51**. When rotating the bobbin **522** of each amplitude control wheel **52** to roll up the corresponding lift cord **6**, the lift cord **6** is guided by the tapered face **522d** and wound round the bobbin **522** smoothly in a good order.

5 Each frequency (ladder tape) modulation control device **53** comprises a frequency control wheel **54**. The frequency control wheel **54** comprises a center through hole **542**, which receives the mounting portion **521b** of the wheel shaft **521** of the corresponding amplitude control wheel **52**, and a protruded portion **541** projecting from one side around the center through hole **542**.

10 Each clutch **55** is comprised of a holder base **551**, a spring member **552**, and a limiter **553**. The holder base **551** is fixedly mounted in the headrail **2**, having a circular center through hole **551a**, a circular recessed hole **551b** in one side around the center through hole **551a**, and two shoulders **551c** and **551d** at two sides of the circular recessed hole **551b** and adapted to stop the protruded portion **541** of the corresponding
15 frequency control wheel **54** to limit the angle of rotation of the corresponding frequency control wheel **54**. The spring member **552** is mounted in the circular recessed hole **551b** and stopped between the holder base **551** and the corresponding frequency control wheel **54**, keeping the corresponding frequency control wheel **54** in friction contact with the annular stop flange **521c** of the wheel shaft **521** of the
20 corresponding amplitude control wheel **52**. The limiter **553** is affixed to the holder base **551** to stop the corresponding frequency control wheel **54** from falling out of the corresponding amplitude control wheel **52**.

 Therefore, the spring power of the spring member **552** impart a push force to the corresponding frequency control wheel **54**, holding the corresponding frequency
25 control wheel **54** in friction engagement with the annular stop flange **521c** of the wheel

shaft **521** of the corresponding amplitude control wheel **52**. When the protruded portion **541** of the frequency control wheel **54** stopped at one shoulder **551c** or **551d** of the corresponding holder base **551** during rotary motion of the frequency control wheel **54** with the corresponding amplitude control wheel **52**, a reactive force is produced
5 (which surpasses the friction force between the frequency control wheel **54** and the annular stop flange **521c** of the wheel shaft **521** of the corresponding amplitude control wheel **52**), thereby causing the frequency control wheel **54** to be disengaged from the corresponding amplitude control wheel **52**. Therefore, similar to the aforesaid first and second embodiments of the present invention, the third embodiment achieves blind slat
10 lifting and tilting control through one single driving source.

Further, at the initial stage in which the wheel shaft **521** is rotated by the rod member **25**, the inside projection **522c** of the bobbin **522** does not touch the key **523**, and the wheel shaft **521** runs idle. After the key **523** stopped against the inside projection **522c** of the bobbin **522** (see FIG. 19 or FIG. 20), the bobbin **522** is rotated
15 with the wheel shaft **521**. When the wheel shaft **521** runs idle, the blind slats are tilted, and the bobbin **522** of the amplitude control wheel **52** of each amplitude (lift cord) modulation control device **51** does no work, i.e. the elevation of the slats does not change.

It is to be understood that the aforesaid rod-like operation device **30** can be
20 formed integral with the input member **21**. Alternatively, the operation device **30** can be detachably coupled to the input member **21**. For example, the operation device **30** can be made having a coupling device or connector at the top end detachably coupled to a coupling device or connector at the bottom side of the input member **21**. When not in use, the operation device **30** can be detached from the input member **21**.

25 Further, a power drive may be installed in the operation device **30**, and

controlled to bias the input member **21** automatically. For example, a motor is installed in the bottom end of the operation device **30**, and an output member is provided at the top end of the operation device **30** and coupled to the input member **21**. When started the motor, the output member is driven by the motor to bias the input member.

5

CLAIMS:

1. A window blind control structure adapted to be installed in a window blind having a headrail and a window body suspended from said headrail, the window blind control structure comprising: a transmission mechanism mounted in said headrail of said window blind, said transmission mechanism having at least one amplitude modulation control device coupled to said window body for controlling lifting of said blind body, at least one frequency modulation control device coupled to said window body for controlling tilting of said window body, and at least one clutch coupled to said amplitude modulation control device and said frequency modulation control device for controlling synchronous action between said amplitude modulation control device and said frequency modulation control device; a linking mechanism mounted in said headrail and coupled to said transmission mechanism, said linking mechanism having an input member adapted to receive an external biasing force, and an actuating member coupled between said input member and said transmission mechanism and adapted to drive said transmission mechanism upon action of said input member; and an operation device coupled to said input member of said linking mechanism for operation by the user to bias said input member; wherein said at least one amplitude modulation control device each comprises an amplitude control wheel; said at least one clutch each comprises a holder base, said holder base having a recessed hole formed in one side thereof and adapted to accommodate the amplitude control wheel of one of said at least one amplitude modulation control device; wherein said at least one frequency modulation control device each comprises a frequency control wheel, said frequency control wheel comprising a

circular through hole, which receives one amplitude control wheel of said at least one amplitude modulation control device; said at least one clutch each further comprises a limiter affixed to the holder base of the corresponding clutch and adapted to stop the corresponding frequency control wheel from falling out of the corresponding amplitude control wheel; wherein said amplitude control wheel has a longitudinal slot formed in the periphery of one end thereof inside the holder base of one of said at least one clutch; said at least one frequency modulation control device each comprises a frequency control wheel, said frequency control wheel having a groove; said at least one clutch each further comprises a spring member mounted in the slot of the amplitude control wheel and stopped at one end thereof with the slot, and a link mounted in the slot of the amplitude control wheel and supported on the other end of said spring member and engageable into the groove of the frequency control wheel of the corresponding frequency modulation control device being mounted on the corresponding amplitude control wheel for enabling the corresponding frequency control wheel to be synchronously rotated with the corresponding amplitude control wheel; and wherein said at least one clutch each further comprises a stop block affixed to one side of the corresponding holder base around the recessed hole of the corresponding holder base, said stop block having a smoothly arched notch formed in a top side thereof and fitting the periphery of the recessed hole of the corresponding holder base, and two sloping faces respectively downwardly extended from two sides of said smoothly arched notch toward the recessed hole of the corresponding holder base and adapted to force the corresponding link away from the corresponding frequency control wheel after rotation of the frequency control wheel of each of

said at least one frequency modulation control device with the amplitude control wheel of each of said at least one amplitude modulation control device through a predetermined angle.

2. The window blind control structure as claimed in claim 1, wherein said input member is rotatably pivoted to said headrail and substantially axially extended in vertical, having a top end mounted with a double-thread worm; said actuating member is a worm gear fastened pivotally with said headrail and meshed with said double-thread worm; said linking mechanism further comprises a rod member axially extended from a center of said worm gear for synchronous rotation and horizontally suspended inside said headrail.

3. The window blind control structure as claimed in claim 1, wherein said operation device is a rod member fixedly extended from a bottom side of said input member to the outside of said headrail for operation by the user.

4. The window blind control structure as claimed in claim 1, wherein said operation device is a rod member having a top end terminating in a coupling device and a bottom end for holding by the user; said input device has a coupling device disposed in a bottom side thereof outside said headrail and adapted to receive the coupling portion of said operation device.

5. The window blind control structure as claimed in claim 1, wherein said operation device comprises a motor mounted in a bottom end thereof, an output member mounted in a top end thereof and coupled to said motor and connectable to said input member for biasing said input member upon operation of said motor.

6. The window blind control structure as claimed in claim 1, wherein said at least one amplitude modulation control device each comprises an amplitude

control wheel, said amplitude control wheel having an axial center through hole axially extended through two distal ends thereof, the axial center through hole of said amplitude control wheel having a non-circular cross-section; said linking mechanism further comprises a rod member connected to said actuating member and adapted to couple said actuating member to said transmission mechanism, said rod member having a noncircular cross-section fitting the axial center through hole of said amplitude control wheel.

7. A window blind control structure adapted to be installed in a window blind having a headrail and a window body suspended from said headrail, the window blind control structure comprising: a transmission mechanism mounted in said headrail of said window blind, said transmission mechanism having at least one amplitude modulation control device coupled to said window body for controlling lifting of said blind body, at least one frequency modulation control device coupled to said window body for controlling tilting of said window body, and at least one clutch coupled to said amplitude modulation control device and said frequency modulation control device for controlling synchronous action between said amplitude modulation control device and said frequency modulation control device; a linking mechanism mounted in said headrail and coupled to said transmission mechanism, said linking mechanism having an input member adapted to receive an external biasing force, and an actuating member coupled between said input member and said transmission mechanism and adapted to drive said transmission mechanism upon action of said input member; and an operation device coupled to said input member of said linking mechanism for operation by the user to bias said input member; wherein said at least one

amplitude modulation control device each comprises an amplitude control wheel, said amplitude control wheel having an outer thread extended around the periphery thereof, said at least one clutch each comprises a holder base, said holder base having an axially extended center through hole and an inner thread extended around the periphery of the axially extended center through hole and threaded onto the outer thread of the amplitude control wheel of one of said at least one amplitude modulation control device for enabling the corresponding amplitude control wheel to be rotated forwards and backwards relative to the corresponding holder base.

8. The window blind control structure as claimed in claim 7, wherein the amplitude control wheel of each of said at least one amplitude modulation control device further has a longitudinal sliding groove longitudinally extended across the outer thread; said at least one frequency modulation control device each comprises a frequency control wheel sleeved onto the amplitude control wheel of one of said at least one amplitude modulation control device, said frequency control wheel having a groove; said at least one clutch each further comprises a link mounted in the longitudinal sliding groove of the amplitude control wheel of one of said at least one amplitude modulation control device and partially engaged into the groove of the frequency control wheel of one of said at least one frequency modulation control device for enabling the corresponding frequency control wheel to be rotated with the corresponding amplitude control wheel.

9. The window blind control structure as claimed in claim 8, wherein said holder base has a recessed hole formed in one side thereof around the axially extended center through hole; said at least one clutch each further comprises a

spring member sleeved onto the amplitude control wheel of one of said at least one amplitude modulation control device and supported on a step inside the corresponding holder base, and a pressure ring supported between said spring member and the corresponding link to force said link into engagement with the groove of the corresponding frequency control wheel for enabling the corresponding frequency control wheel to be rotated with the corresponding amplitude control wheel.

10. The window blind control structure as claimed in claim 8, wherein said at least one clutch each further comprises a stop block affixed to the corresponding holder base, said stop block having two sloping faces adapted to force the corresponding link away from the groove of the corresponding frequency control wheel after rotation of the frequency control wheel of each of said at least one frequency modulation control device with the amplitude control wheel of each of said at least one amplitude modulation control device through a predetermined angle.

11. A window blind control structure adapted to be installed in a window blind having a headrail and a window body suspended from said headrail, the window blind control structure comprising: a transmission mechanism mounted in said headrail of said window blind, said transmission mechanism having at least one amplitude modulation control device coupled to said window body for controlling lifting of said blind body, at least one frequency modulation control device coupled to said window body for controlling tilting of said window body, and at least one clutch coupled to said amplitude modulation control device and said frequency modulation control device for controlling synchronous action between

said amplitude modulation control device and said frequency modulation control device; a linking mechanism mounted in said headrail and coupled to said transmission mechanism, said linking mechanism having an input member adapted to receive an external biasing force, and an actuating member coupled between said input member and said transmission mechanism and adapted to drive said transmission mechanism upon action of said input member; and an operation device coupled to said input member of said linking mechanism for operation by the user to bias said input member; wherein said at least one amplitude modulation control device each comprises an amplitude control wheel, said amplitude control wheel comprising a wheel shaft coupled to said linking mechanism, said wheel shaft having a key hole in the periphery thereof, a bobbin sleeved onto said wheel shaft, said bobbin having a first axial center hole extended to one end thereof, a second axial center hole extended to an opposite end thereof in communication and line with said first axial center hole, said second axial center hole having a diameter greater than said first axial center hole, and an inside projection suspended in said second axial center hole and disposed in contact with the periphery of said wheel shaft, and a key mounted in the key hole of said wheel shaft and partially protruded over the periphery of said wheel shaft and adapted to stop and push the inside projection of said bobbin and to further rotate said bobbin upon rotary motion of said wheel shaft.

12. The window blind control structure as claimed in claim 11, wherein said wheel shaft has a center trough hole axially extended through two distal ends thereof, the center through hole of said wheel shaft having a non-circular cross-section; said linking mechanism comprises a non-circular rod member fitted into

the center through hole of said wheel shaft to couple said wheel shaft to said linking mechanism.

13. The window blind control structure as claimed in claim 11, wherein said inside projection of said bobbin spaces the periphery of said second axial center hole from the periphery of said wheel shaft, for enabling said bobbin to be rotated relative to said wheel shaft within a predetermined angle.

14. The window blind control structure as claimed in claim 11, wherein said wheel shaft comprises a bearing portion adapted to support said bobbin, said bearing portion having an outer diameter approximately equal to the first axial center hole of said bobbin.

15. The window blind control structure as claimed in claim 14, wherein said wheel shaft further comprises a mounting portion axially extended from one end of said bearing portion, and an annular stop flange extended around the periphery between said mounting portion and said bearing portion; said at least one frequency modulation control device each comprises a frequency control wheel, said frequency control wheel having a center through hole, which receives of the mounting portion of the wheel shaft of the amplitude control wheel of one of said at least one amplitude modulation control device for enabling said frequency control wheel to be maintained in friction contact with the annular stop flange of the wheel shaft of the corresponding amplitude control wheel.

16. The window blind control structure as claimed in claim 15, wherein said at least one clutch each comprises a holder base, said holder base comprising a center through hole and a recessed hole formed in one side thereof around said center through hole, a spring member supported in the recessed hole of said

holder base and stopped between said holder base and the frequency control wheel of one of said at least one frequency modulation control device to force the corresponding frequency control wheel into friction contact with the annular stop flange of the wheel shaft of the amplitude control wheel of one of said at least one amplitude modulation control device.

17. The window blind control structure as claimed in claim 16, wherein said at least one clutch each further comprises a limiter affixed to the corresponding holder base and adapted to stop the corresponding frequency control wheel from falling out of the corresponding amplitude control wheel.

18. The window blind control structure as claimed in claim 16, wherein the frequency control wheel of each of said at least one frequency modulation control device has a protruded portion projecting from one side thereof-, the holder base of each of said at least one clutch has two shoulders disposed at two sides of the recessed hole of the corresponding holder and adapted to stop the protruded portion of the corresponding frequency control wheel during rotary motion of the corresponding frequency control wheel with the corresponding amplitude control wheel and to further force the corresponding frequency control wheel out of engagement with the corresponding amplitude control wheel.

19. The window blind control structure as claimed in claim 18, wherein the reactive force upon contact of the protruded portion of the frequency control wheel with one shoulder of the corresponding holder base is greater than the friction resistance between the corresponding frequency control wheel and the corresponding amplitude control wheel.

20. A window blind control structure adapted to be installed in a window

blind having a headrail and a window body suspended from said headrail, the window blind control structure comprising: a transmission mechanism mounted in said headrail of said window blind, said transmission mechanism having at least one amplitude modulation control device coupled to said window body for controlling lifting of said blind body, at least one frequency modulation control device coupled to said window body for controlling tilting of said window body, and at least one clutch coupled to said amplitude modulation control device and said frequency modulation control device for controlling synchronous action between said amplitude modulation control device and said frequency modulation control device; a linking mechanism mounted in said headrail and coupled to said transmission mechanism, said linking mechanism having an input member adapted to receive an external biasing force, and an actuating member coupled between said input member and said transmission mechanism and adapted to drive said transmission mechanism upon action of said input member; and an operation device coupled to said input member of said linking mechanism for operation by the user to bias said input member; wherein said linking mechanism further comprises self-locking means, which allows said input device to bias said actuating member but prohibits said actuating member from biasing said input member.

21. The window blind control structure as claimed in 20, wherein said at least one amplitude modulation control device each comprises an amplitude control wheel; said at least one clutch each comprises a holder base, said holder base having a recessed hole formed in one side thereof and adapted to accommodate the amplitude control wheel of one of said at least one amplitude

modulation control device.

22. The window blind control structure as claimed in claim 20, wherein said at least one frequency modulation control device each comprises a frequency control wheel, said frequency control wheel comprising a circular through hole, which receives one amplitude control wheel of said at least one amplitude modulation control device; said at least one clutch each further comprises a limiter affixed to the holder base of the corresponding clutch and adapted to stop the corresponding frequency control wheel from falling out of the corresponding amplitude control wheel.

23. The window blind control structure as claimed in claim 20, wherein said amplitude control wheel has a longitudinal slot formed in the periphery of one end thereof inside the holder base of one of said at least one clutch; said at least one frequency modulation control device each comprises a frequency control wheel, said frequency control wheel having a groove; said at least one clutch each further comprises a spring member mounted in the slot of the amplitude control wheel and stopped at one end thereof with the slot, and a link mounted in the slot of the amplitude control wheel and supported on the other end of said spring member and engageable into the groove of the frequency control wheel of the corresponding frequency modulation control device being mounted on the corresponding amplitude control wheel for enabling the corresponding frequency control wheel to be synchronously rotated with the corresponding amplitude control wheel.

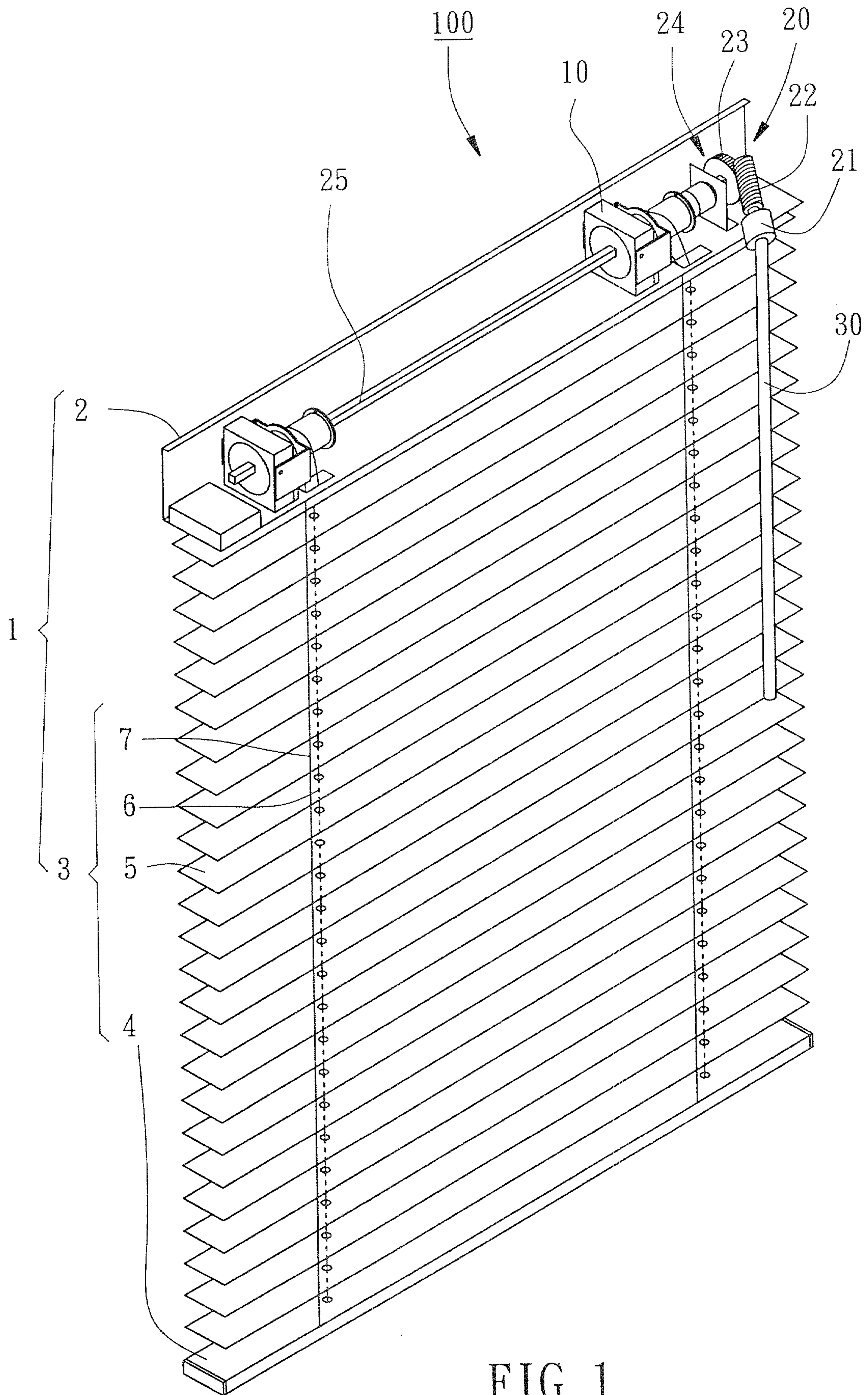

FIG. 1

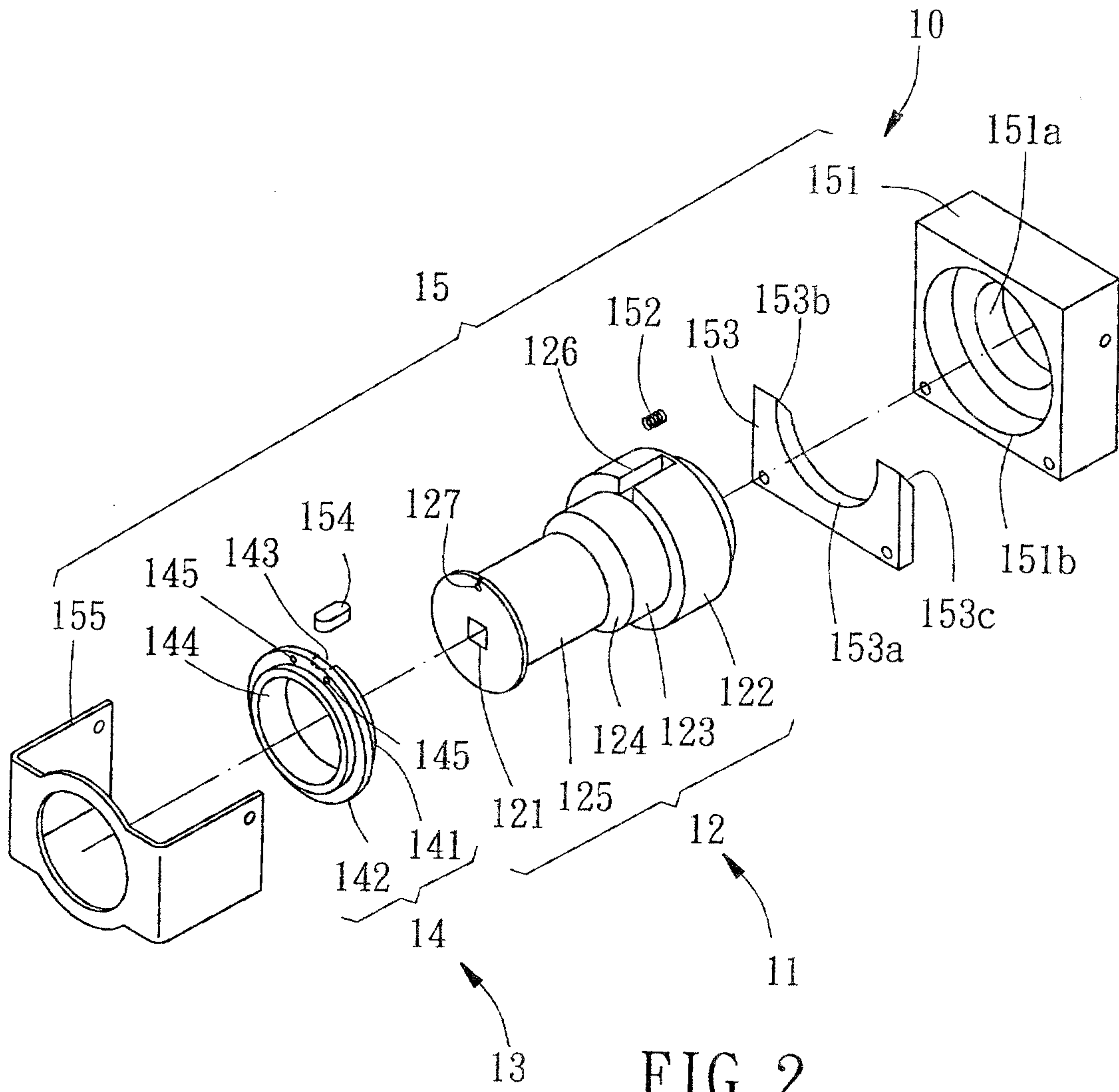

FIG. 2

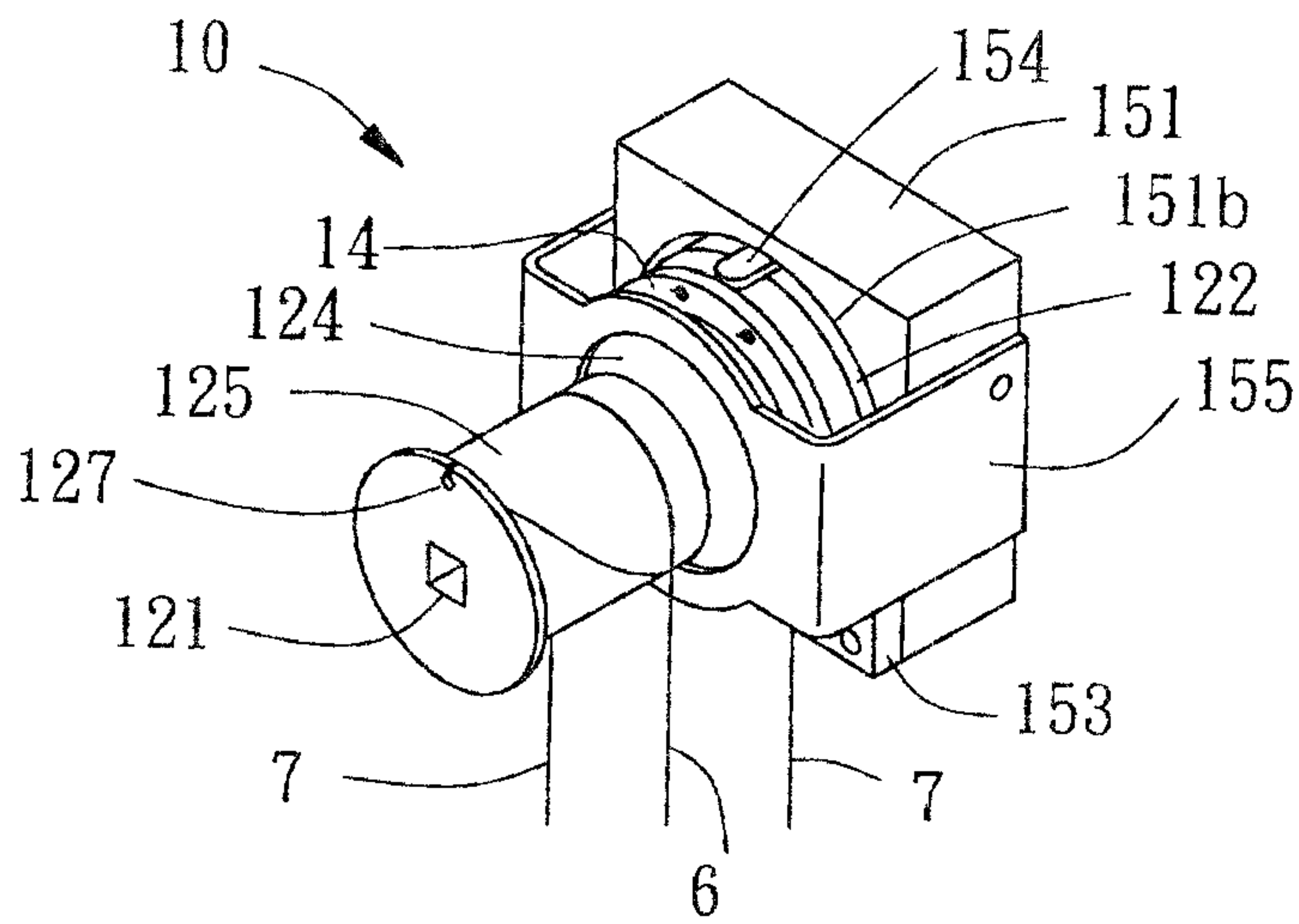

FIG. 3

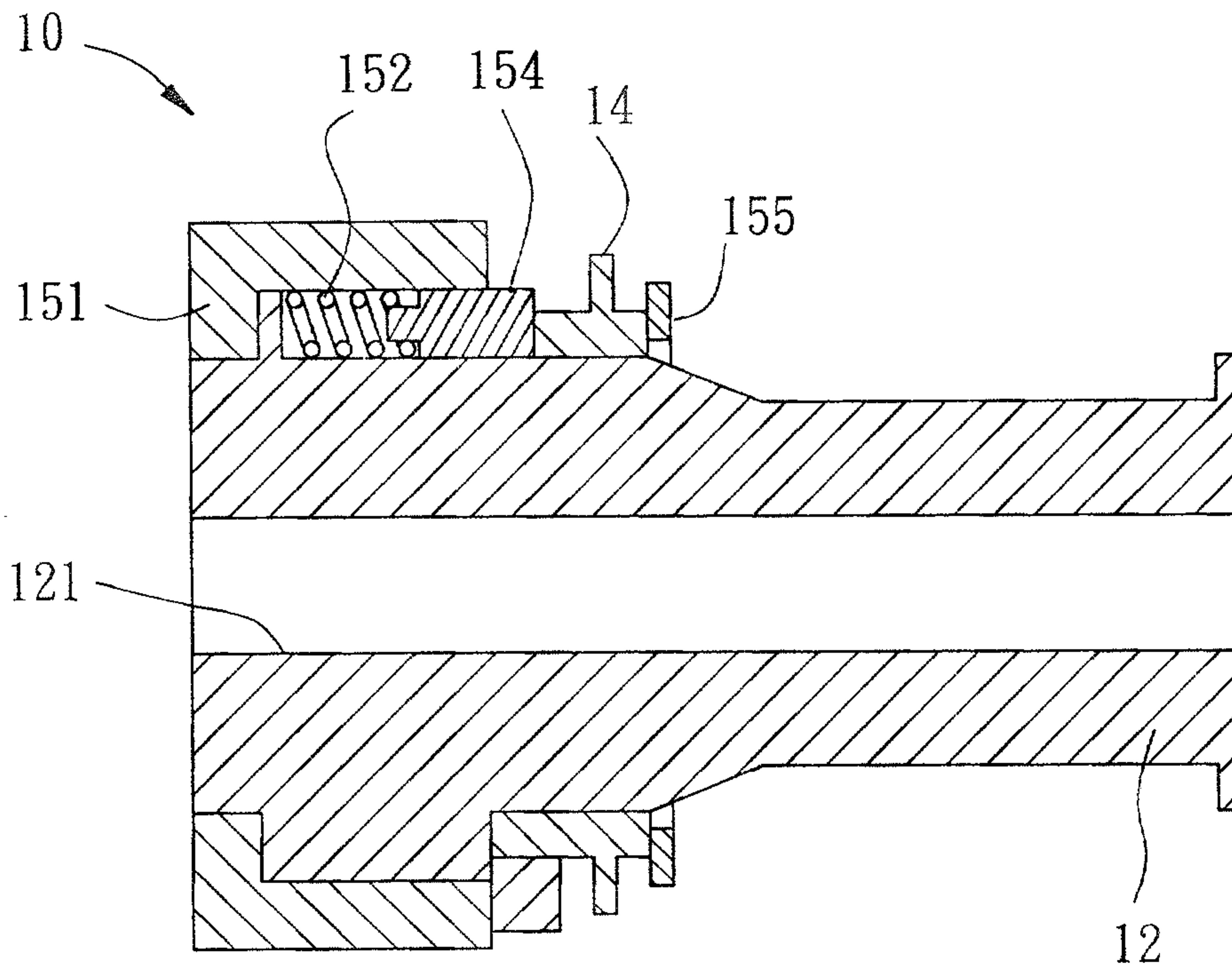

FIG. 4

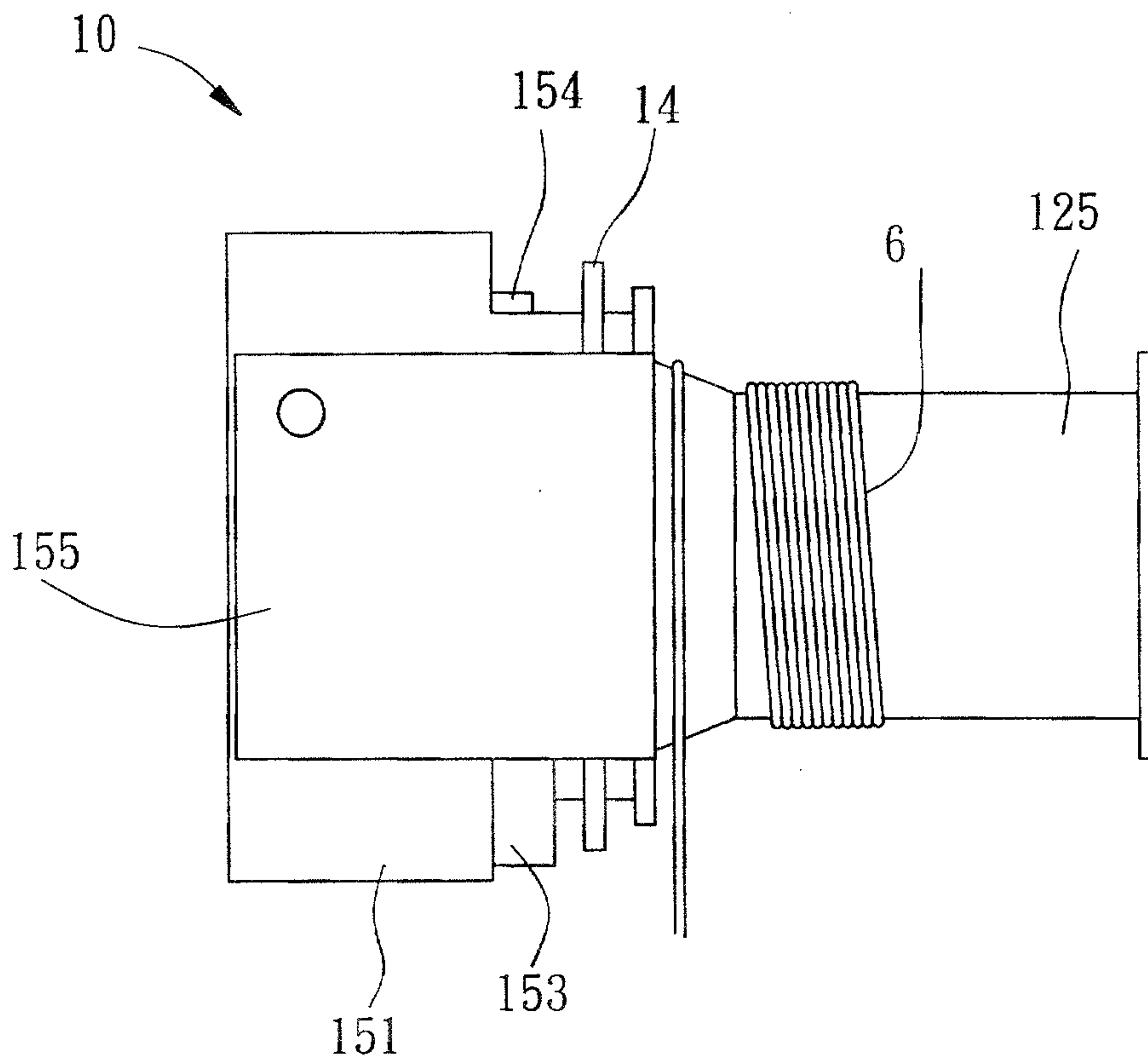

FIG. 5

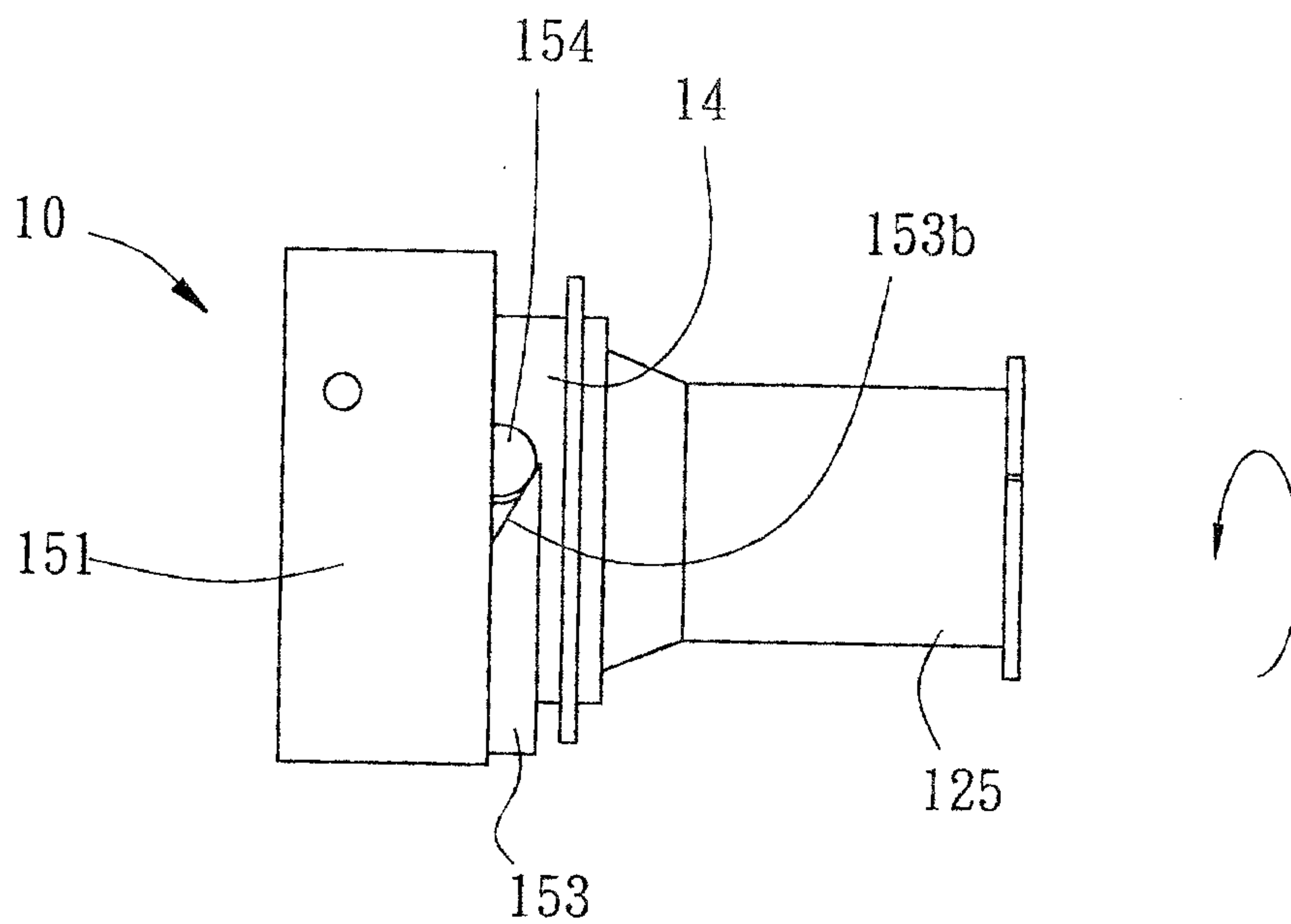

FIG. 6

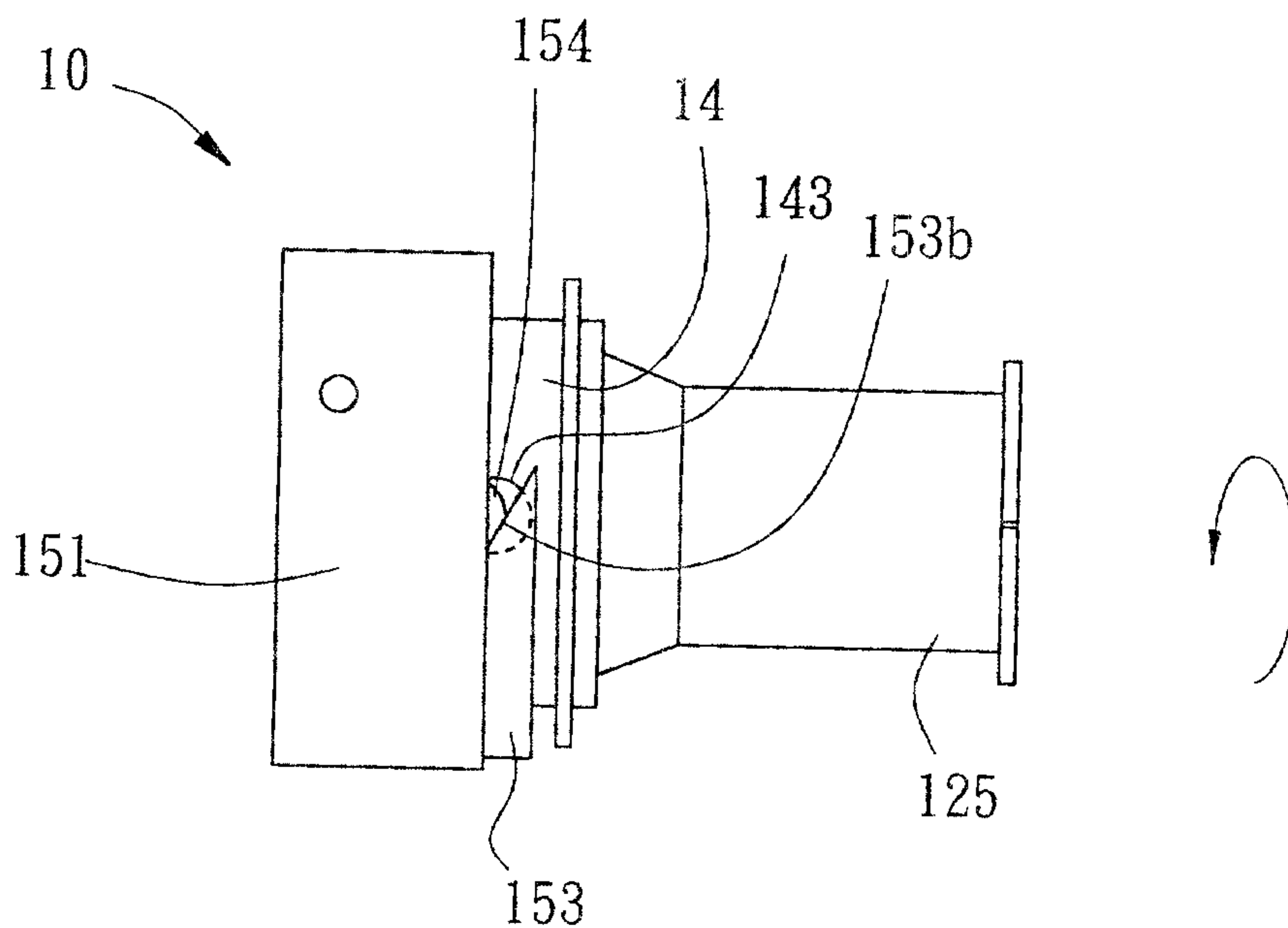

FIG. 7

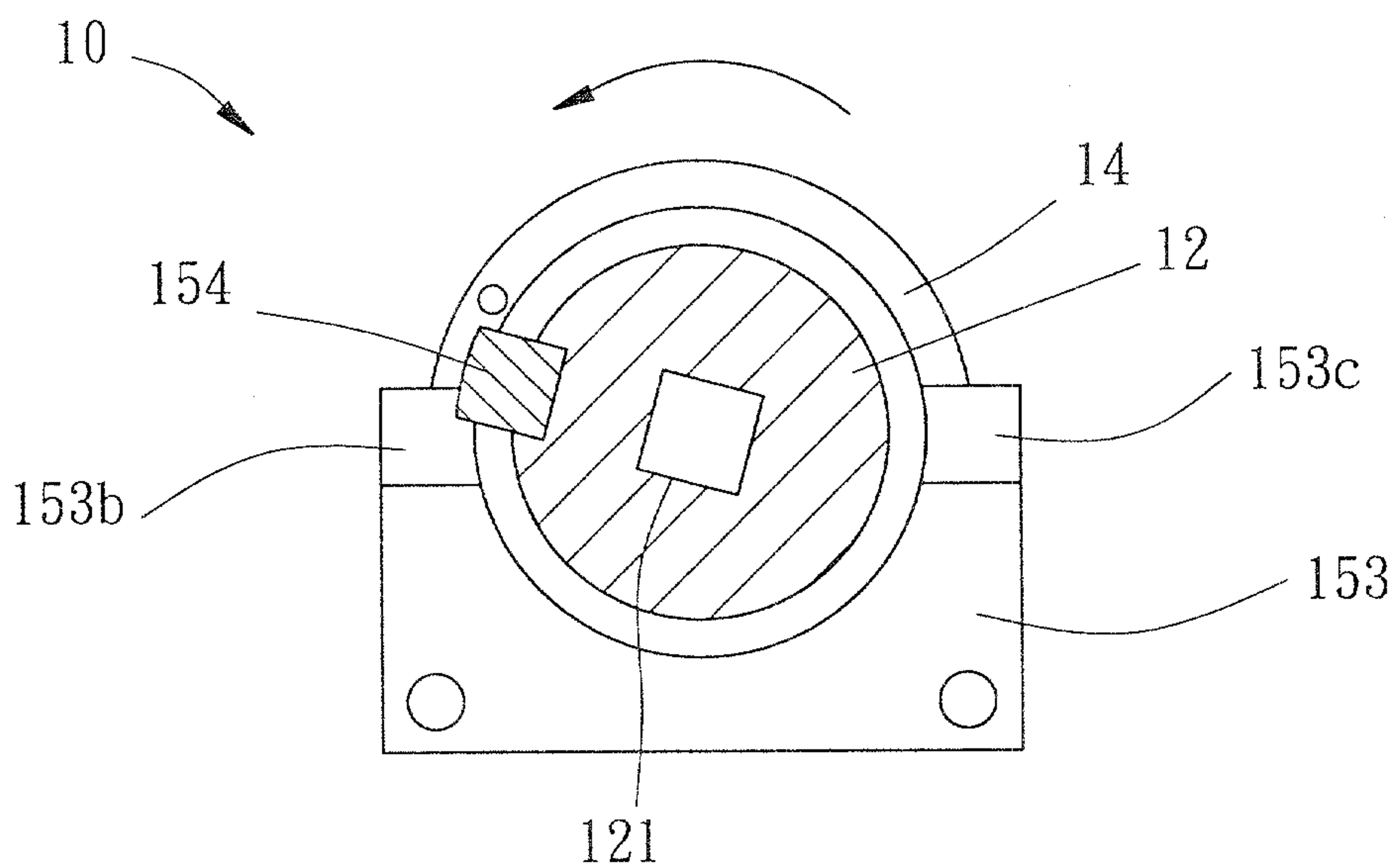

FIG. 8

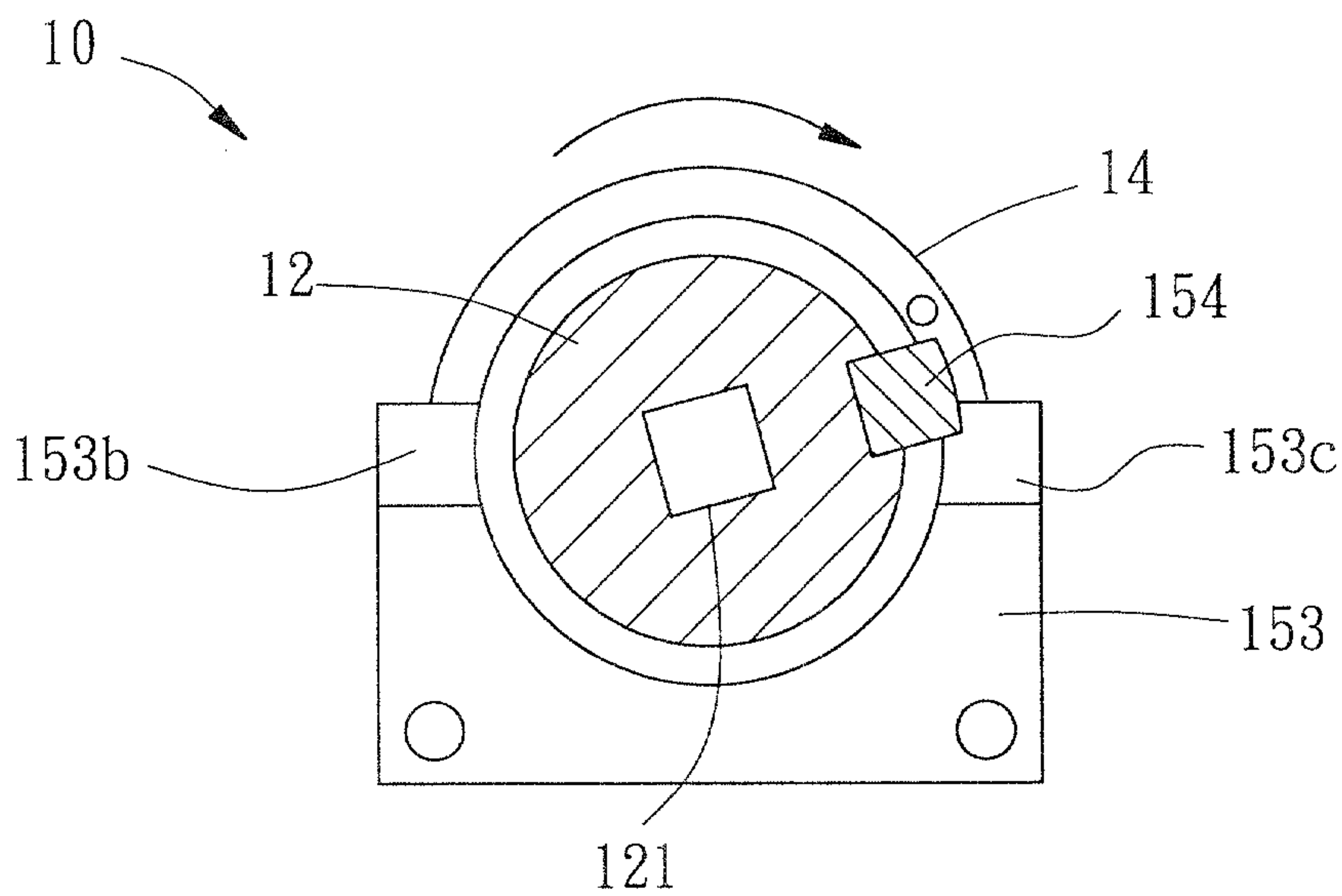

FIG. 9

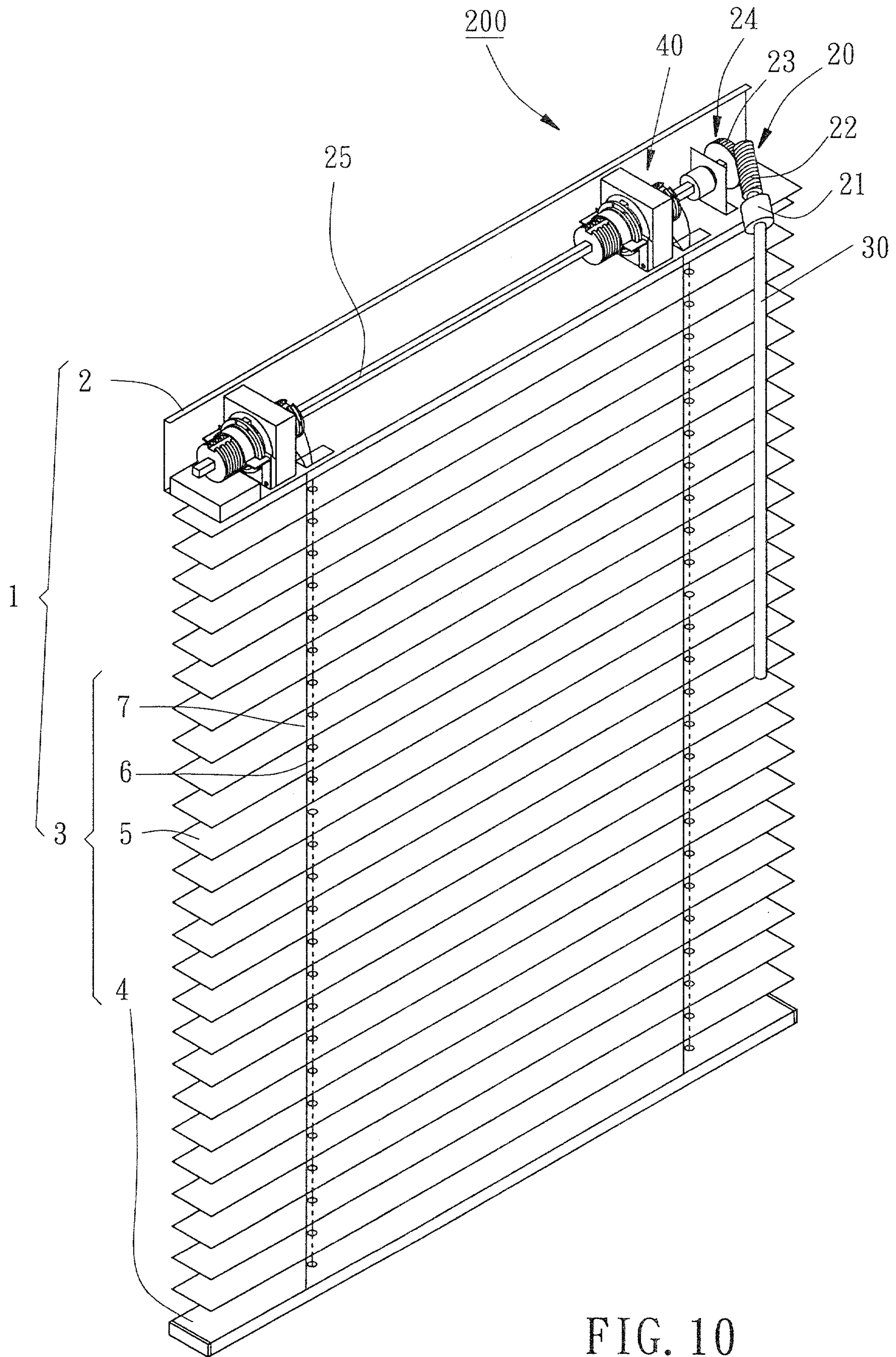

FIG. 10

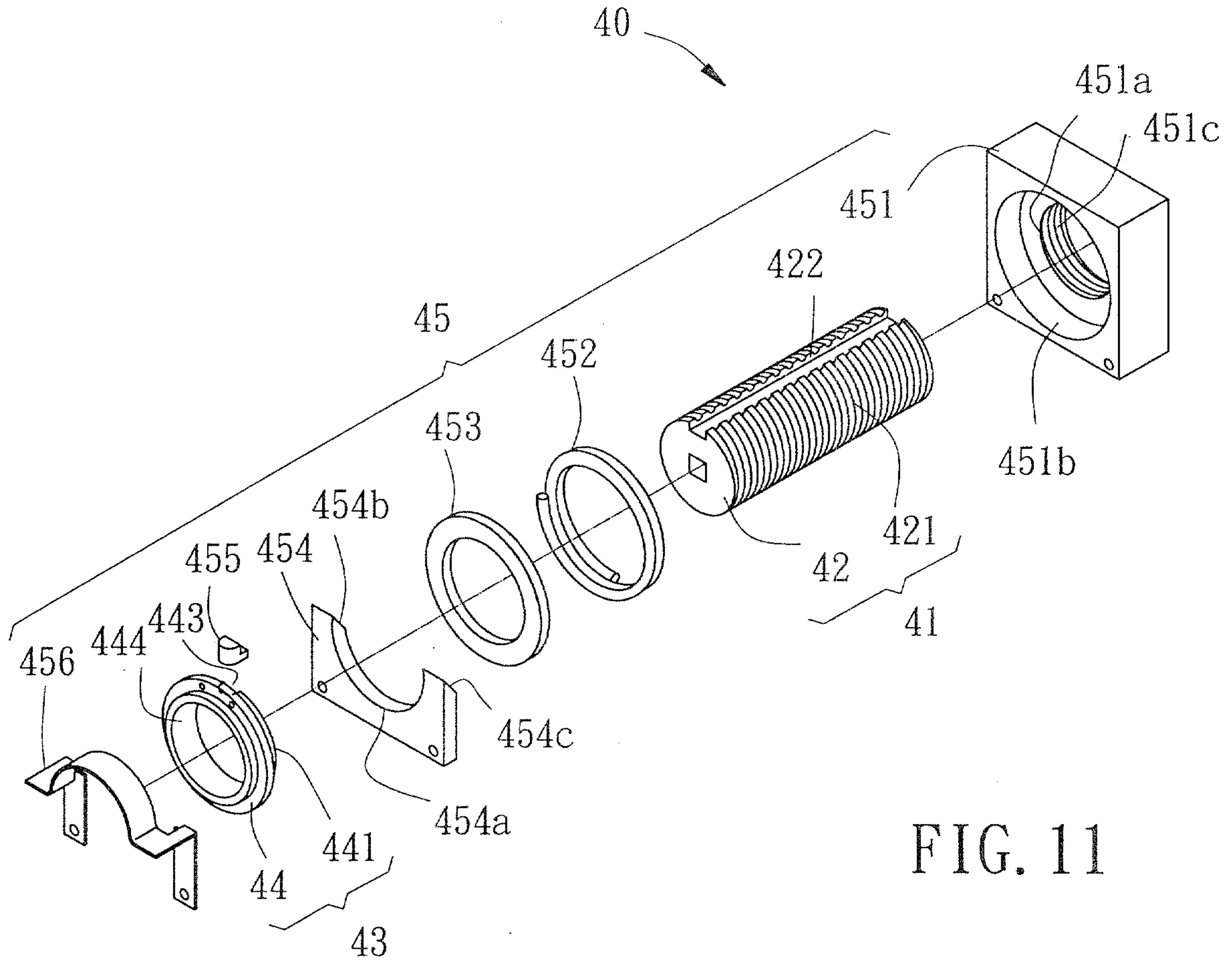

FIG. 11

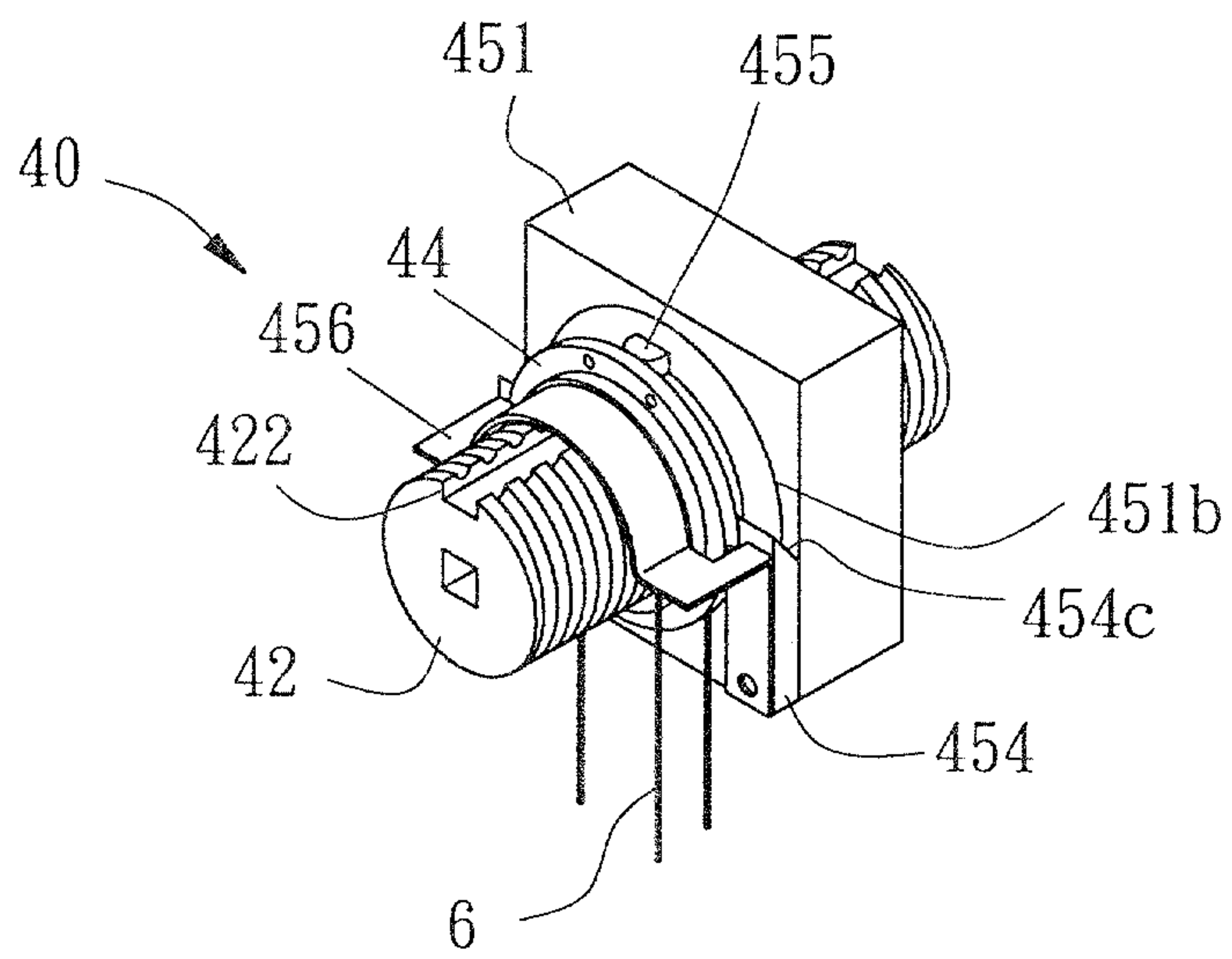

FIG. 12

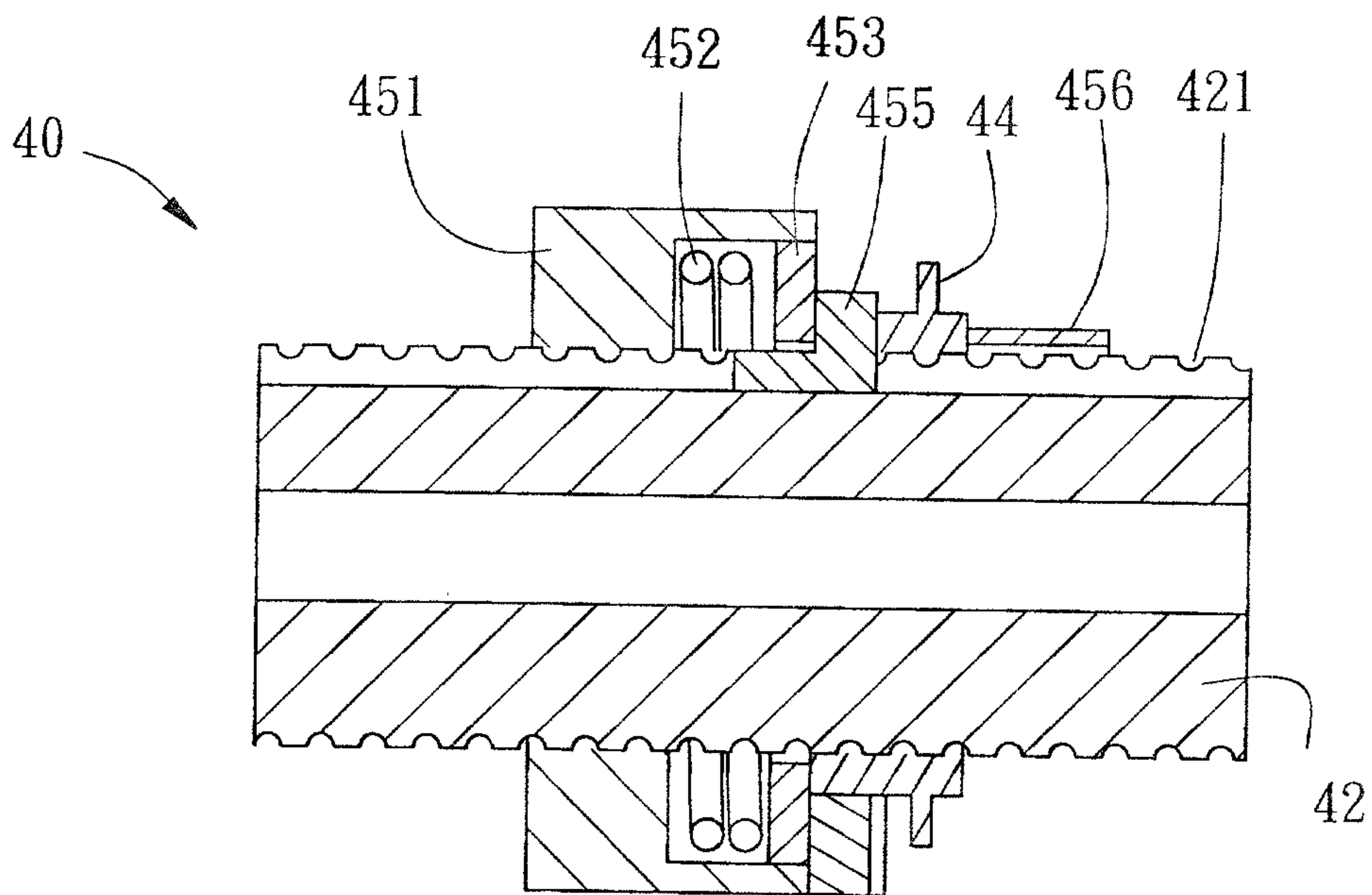

FIG. 13

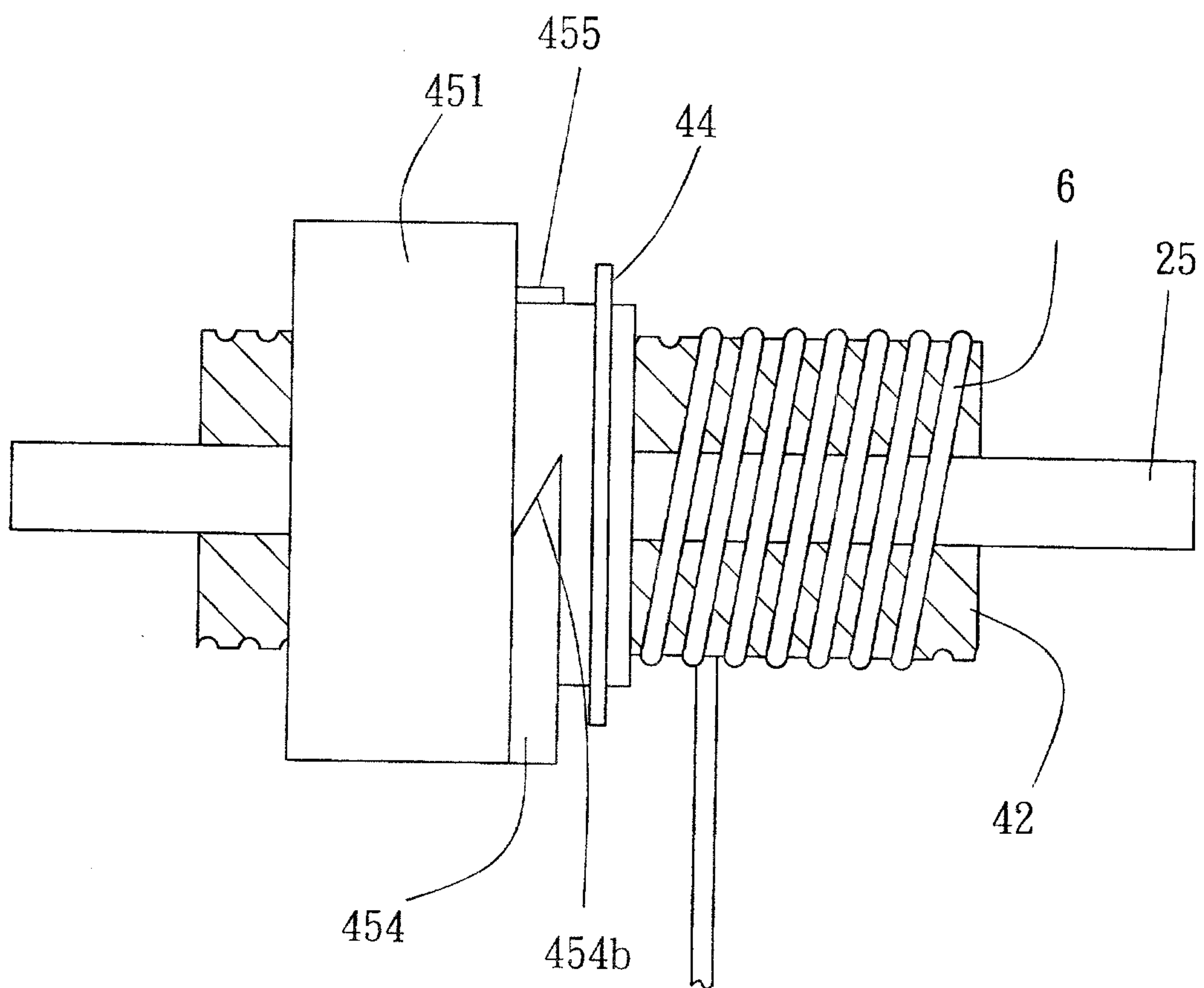

FIG. 14

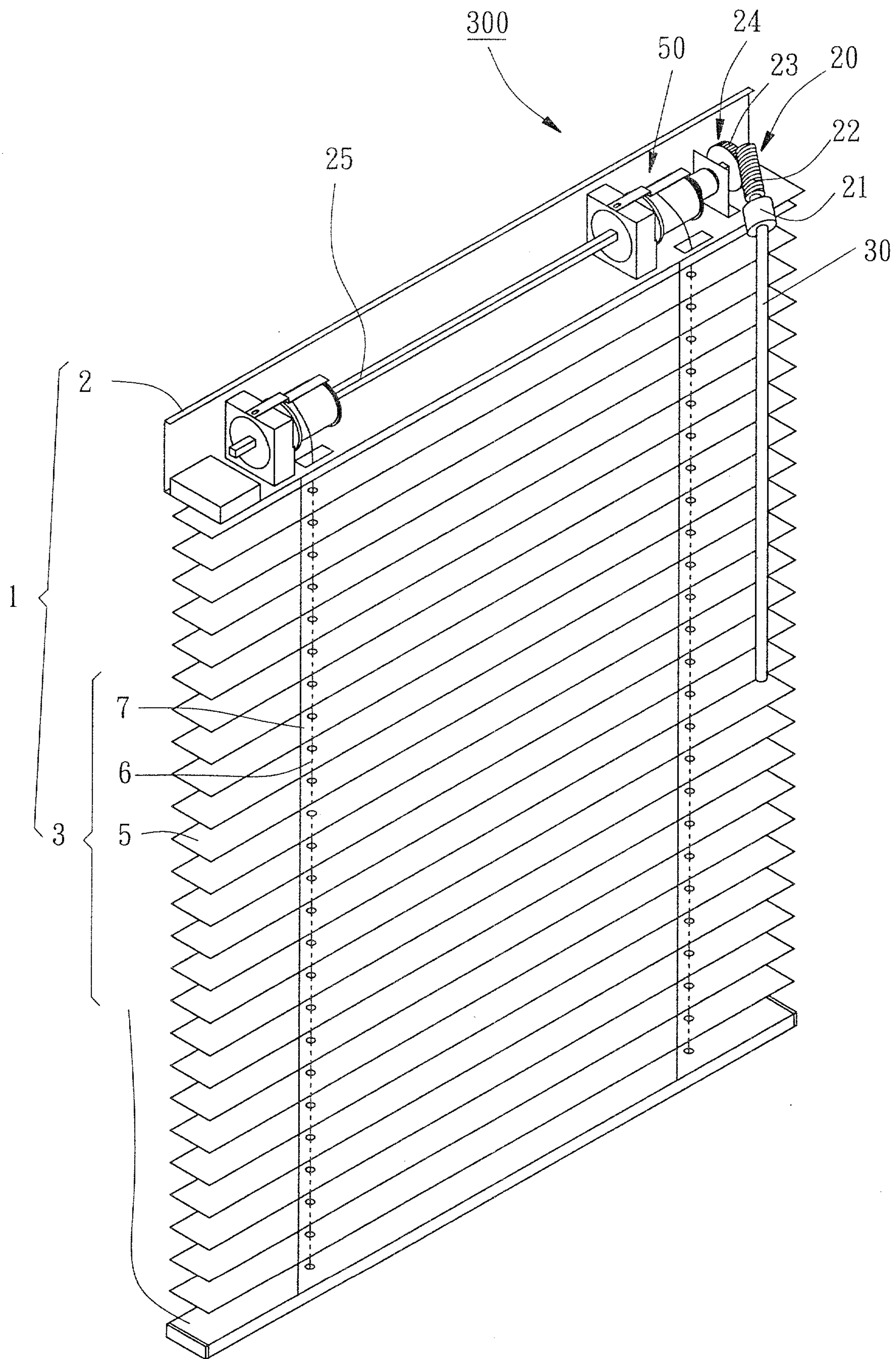

FIG. 15

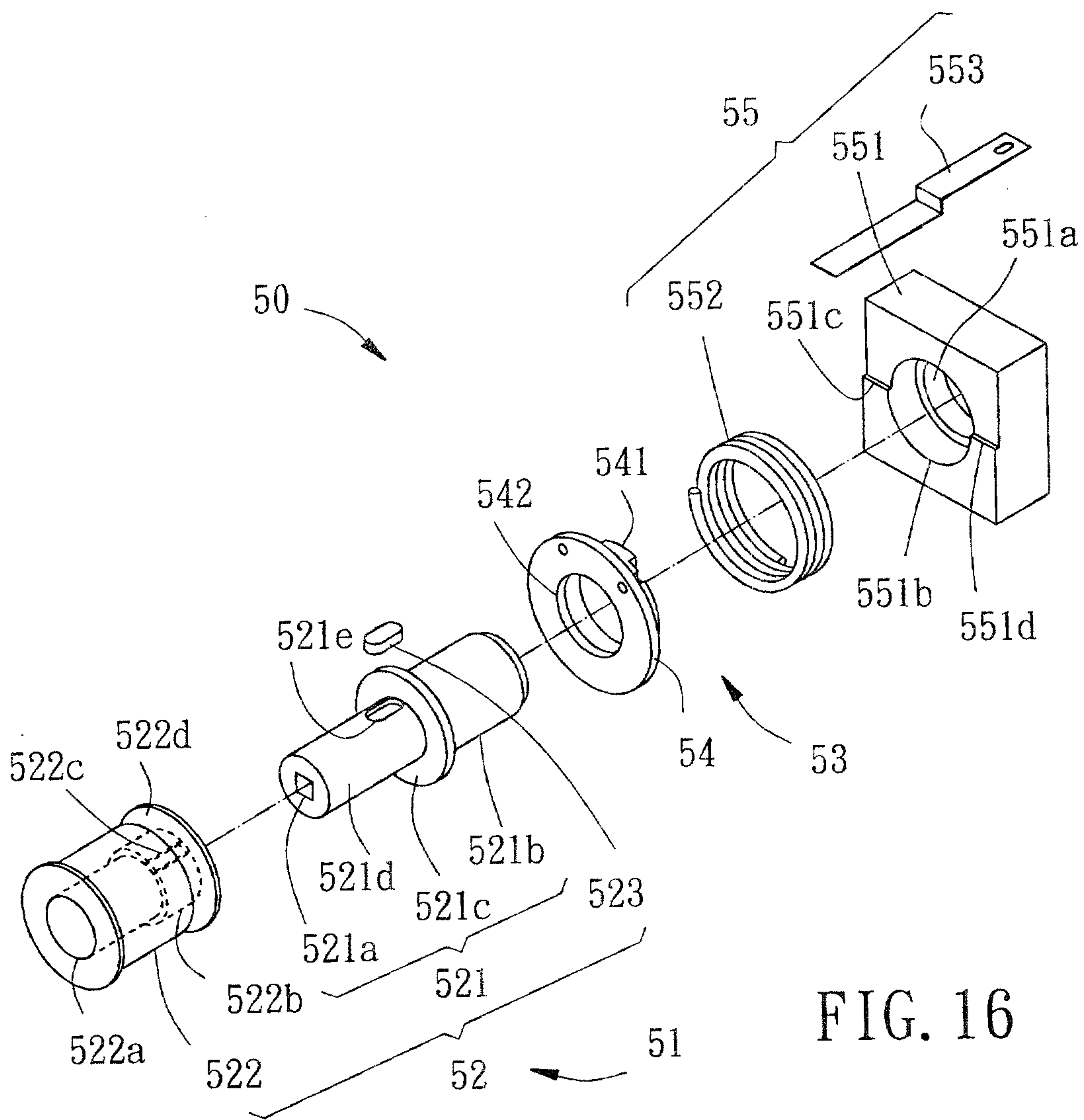

FIG. 16

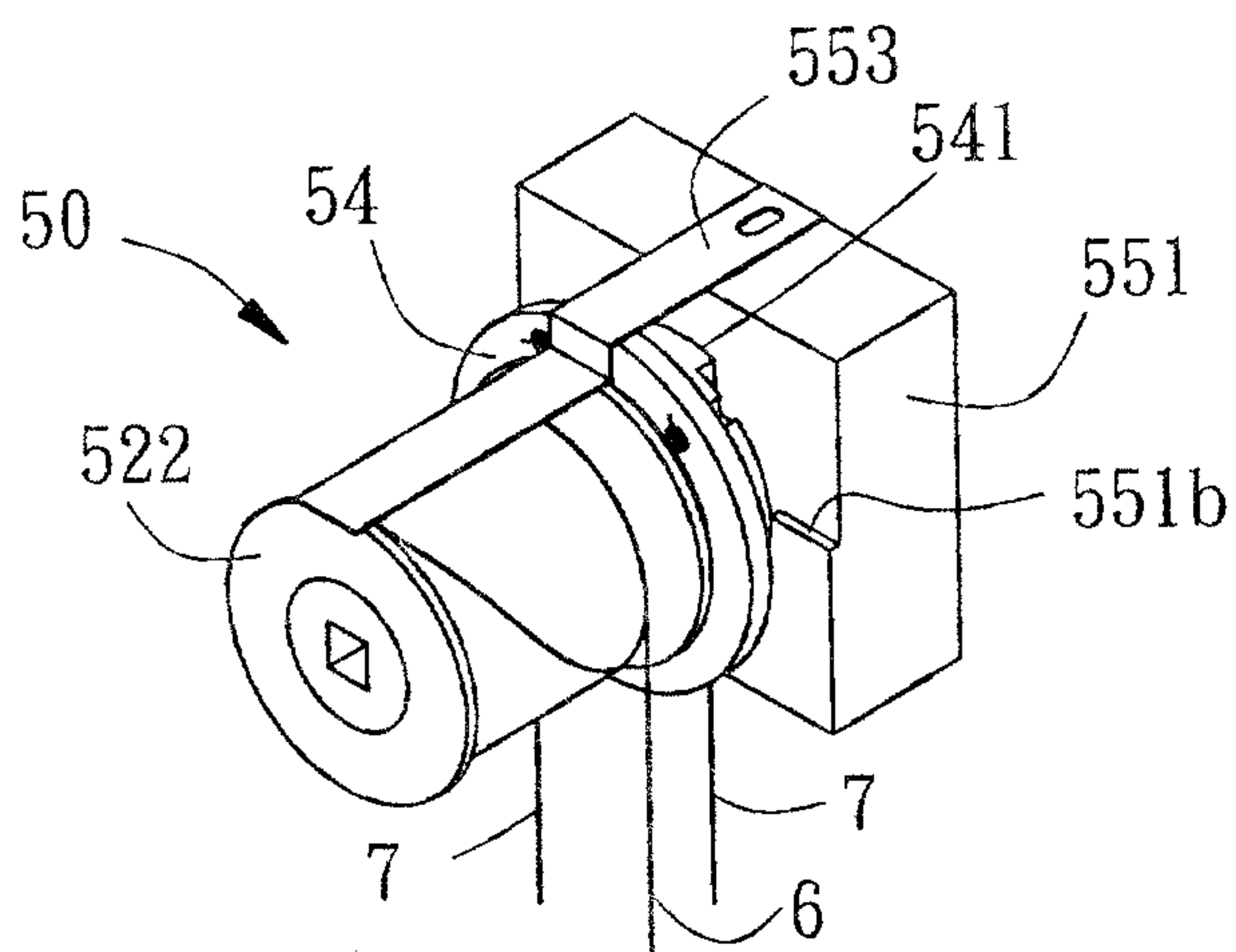

FIG. 17

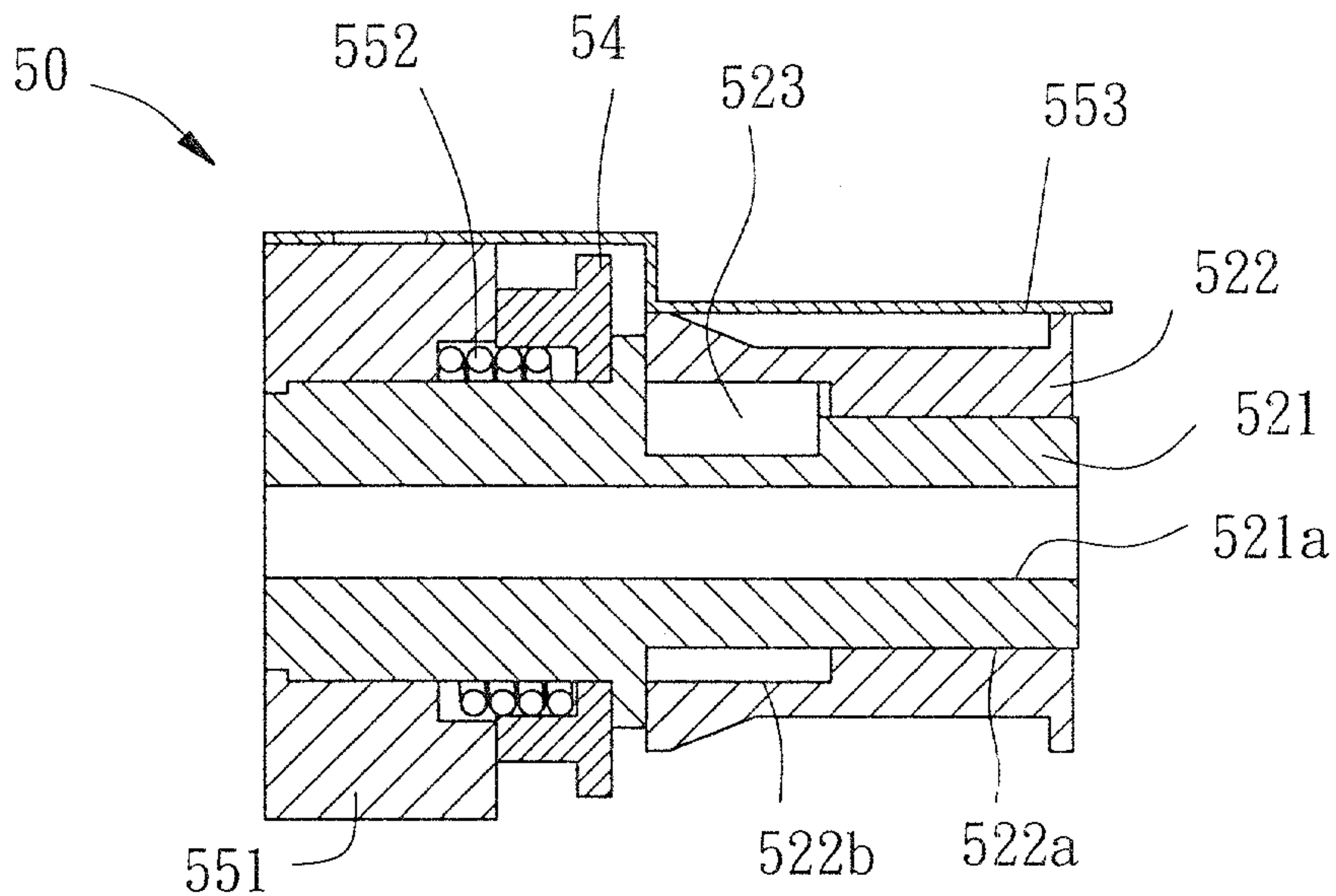

FIG. 18

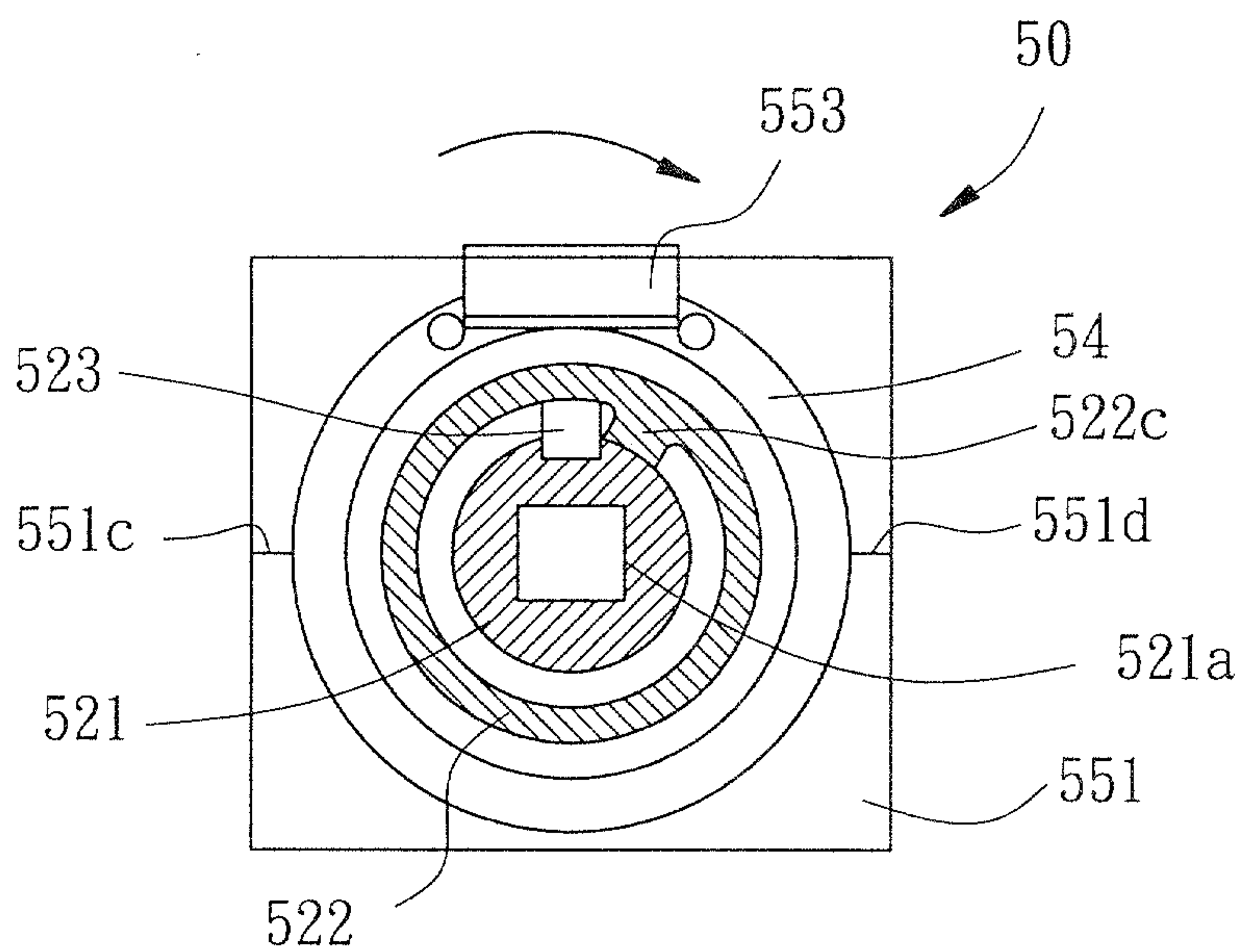

FIG. 19

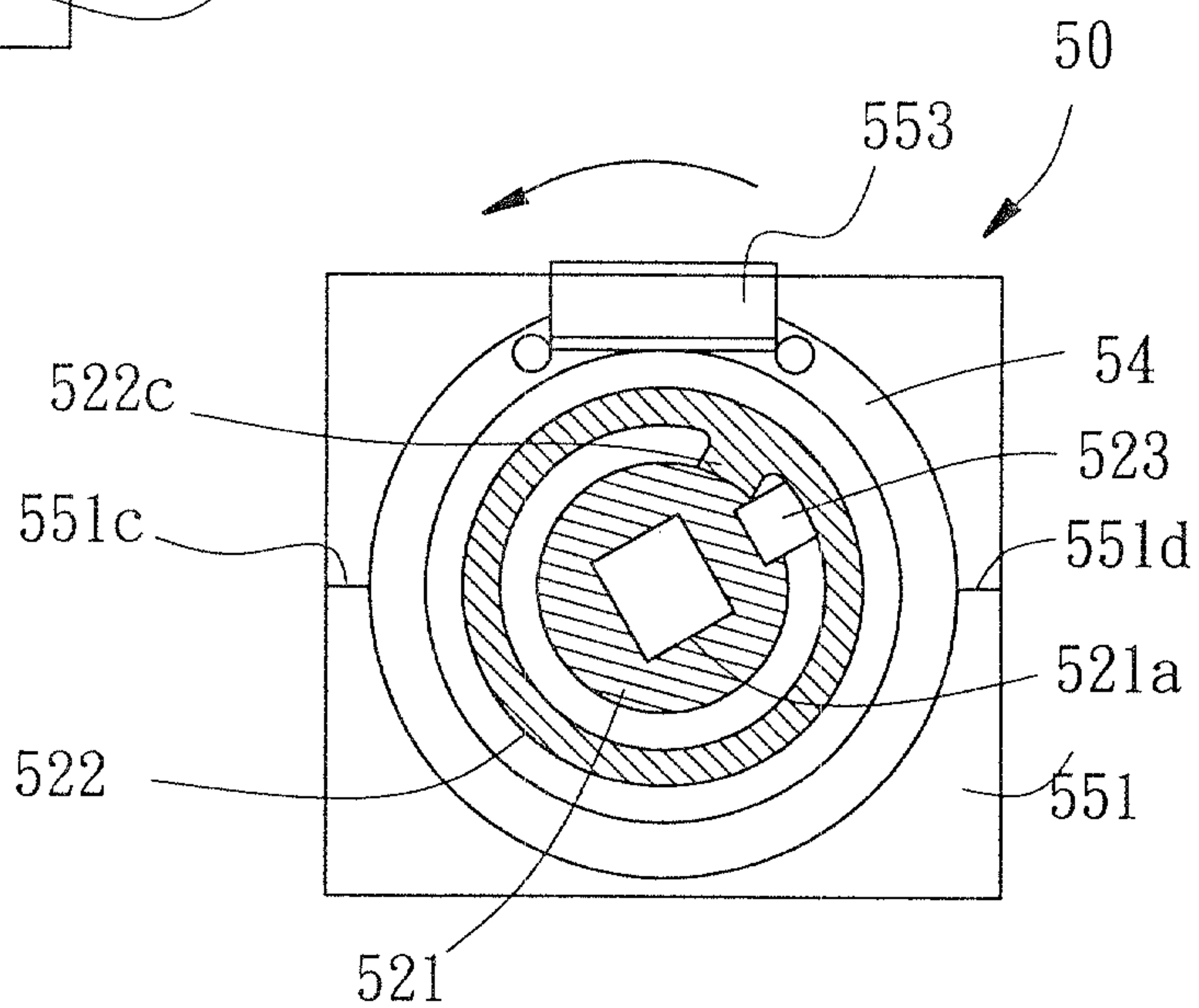

FIG. 20

