



(22) Date de dépôt/Filing Date: 2007/06/12

(41) Mise à la disp. pub./Open to Public Insp.: 2008/12/12

(45) Date de délivrance/Issue Date: 2014/07/08

(51) Cl.Int./Int.Cl. *A01B 73/06* (2006.01)

(72) Inventeur/Inventor:
HULICKO, LES, CA

(73) Propriétaire/Owner:
HULICKO, LES, CA

(74) Agent: MACPHERSON LESLIE & TYERMAN LLP

(54) Titre : INSTRUMENT ARATOIRE AVEC DISPOSITIF ARRIERE REPLIABLE POUR LE TRANSPORT

(54) Title: IMPLEMENT WITH REAR FOLDING TRANSPORT

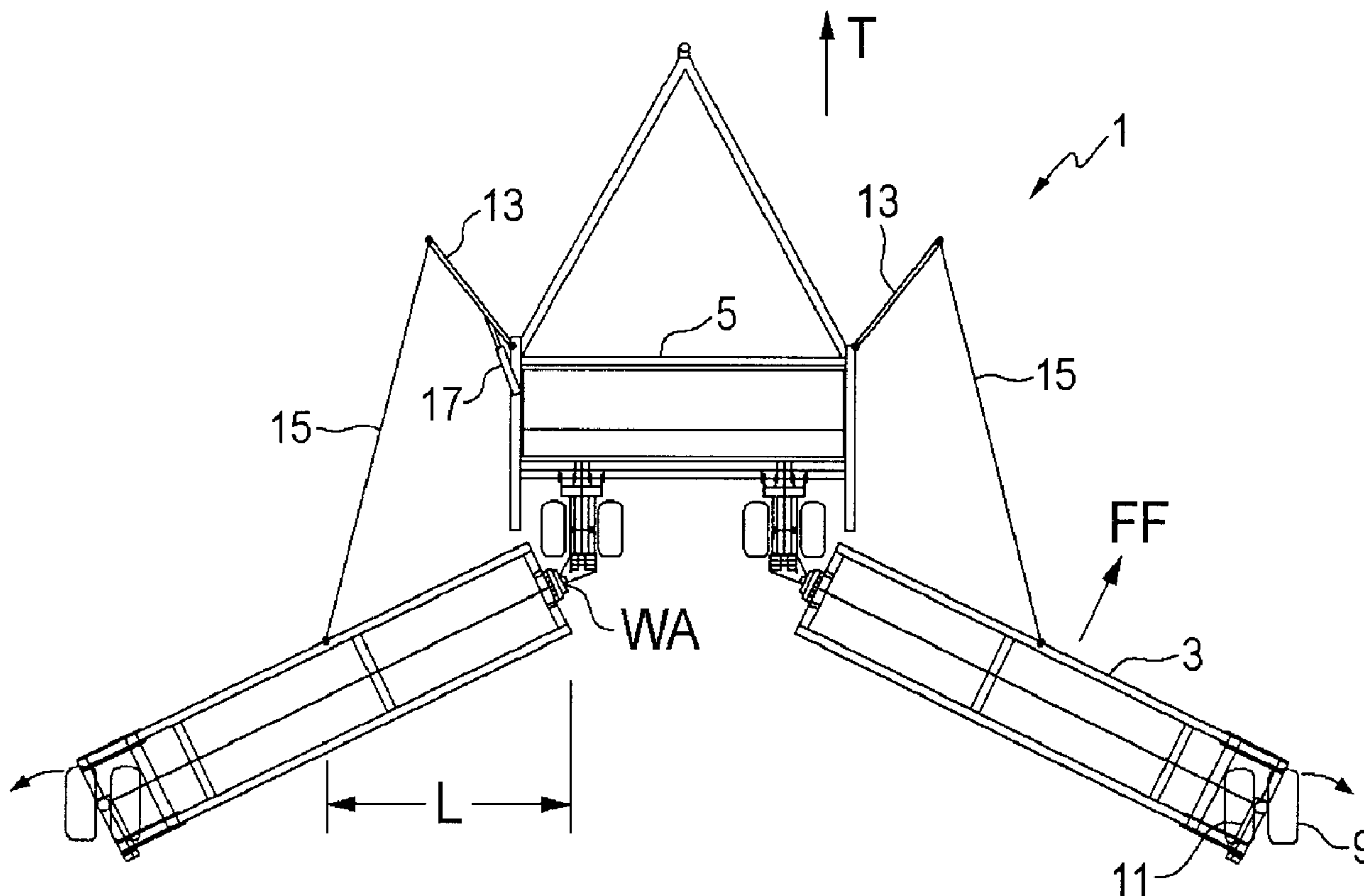

(57) Abrégé/Abstract:

An agricultural implement apparatus comprises a center section mounted on main wheels oriented to carry the center section in an operating travel direction. Right and left wings are pivotally attached to corresponding right and left ends of the center section about substantially vertical wing pivot axes, and right and left wing wheels are mounted at outer locations on the corresponding right and left wings operative to support the wings for travel in the operating travel direction. The wing wheels are pivotally mounted to the wings about substantially vertical right and left wheel axes. The wings can pivot from a transport position, where the wings extend



(57) **Abrégé(suite)/Abstract(continued):**

rearward from ends of the center section and are oriented substantially in alignment with the operating travel direction and where a rotational plane of each wing wheel is substantially aligned with the corresponding wing section and with the operating travel direction, to a field position where the wings extend laterally from ends of the center section and where a rotational plane of each wing wheel is aligned with the operating travel direction. Right and left wheel actuators are operative to pivot the right and left wing wheels about their respective wheel axes from the transport position to the field position as the apparatus moves in the operating travel direction.

ABSTRACT

An agricultural implement apparatus comprises a center section mounted on main wheels oriented to carry the center section in an operating travel direction. Right and left wings are pivotally attached to corresponding right and left ends of the center section about substantially vertical wing pivot axes, and right and left wing wheels are mounted at outer locations on the corresponding right and left wings operative to support the wings for travel in the operating travel direction. The wing wheels are pivotally mounted to the wings about substantially vertical right and left wheel axes. The wings can pivot from a transport position, where the wings extend rearward from ends of the center section and are oriented substantially in alignment with the operating travel direction and where a rotational plane of each wing wheel is substantially aligned with the corresponding wing section and with the operating travel direction, to a field position where the wings extend laterally from ends of the center section and where a rotational plane of each wing wheel is aligned with the operating travel direction. Right and left wheel actuators are operative to pivot the right and left wing wheels about their respective wheel axes from the transport position to the field position as the apparatus moves in the operating travel direction.

10 **BACKGROUND**

In some types of wider implements it is known to fold the wings of the implement from a field position, where right and left wings are extended substantially perpendicular to the operating travel direction, rearward and backward to a transport position where the wings
15 are substantially parallel and aligned in the travel direction. Such an implement is disclosed for example in United States Patent Number 4,821,809 to Summach et al. which discloses a rear folding drawbar such as would be used for carrying harrows, packers, and the like. Rear fold transport is relatively inexpensive compared to transport systems where the wings are folded upward.

20

Rear fold is therefore popular with relatively lighter implements such as harrows, sprayers, packers, and the like which are relatively easy to pull, and typically are very

wide. Rear fold is also popular for land rollers which typically comprise large and heavy cylindrical drums mounted to the center section and to each wing for rolling land to smooth the surface and push rocks and the like into the ground to facilitate harvesting short crops.

5

A typical implement will have a center section mounted on fixed wheels, with the right and left wings pivotally attached to corresponding right and left ends of the center section about a vertical axis. Wheels supporting the outside ends of the wings are typically castering wheels free to pivot about a vertical caster axis so as to roll along the ground in
10 any direction as dictated by the position of the wing. In the field position the wings are typically maintained perpendicular to the operating travel direction by a cable, bar, or like brace extending forward and inward from a middle portion of the wing to the center section.

15 When moving from the field position to the transport position, the braces are released and as the towing vehicle moves the center section forward, the wings fall back into alignment with the operating travel direction and the wheels caster into alignment with the operating travel direction. With implements where the wings are light, such as agricultural sprayers, often the operator manually moves the wings out from the transport
20 position to the field position and attaches the braces. However where the wings are heavier, such as with harrows, packers, land rollers, and the like, moving from the transport position to the field position requires maneuvering the wings by turning to one side, backing up, or the like such that one of the wings extends laterally from the center

section so that the brace can be attached, and then turning the opposite way or backing up to similarly orient the other wing and attach the brace for it.

It is also known to provide a mechanism for pulling the wings forward, such as that
5 disclosed in United States Patent Number 4,709,857 to Wilger directed to transport system for a sprayer. In the Wilger sprayer the wing wheels are controlled by a hydraulic cylinder that moves them 90 degrees with respect to the wing. In the transport position the wheels are aligned parallel with the wing. To move from transport to field position the implement is stopped in the field, and the wing wheels are moved 90 degrees such
10 that the wheels are perpendicular to the wing. A power fold arm then pulls the wings outward and forward to the field position where the wheels are aligned with the operating travel direction in the field position, and braces are latched to maintain the wings in the field position. The implement may then be moved forward.

15 Rear folding agricultural sprayers with their light weight wings present relatively minor challenges compared to the much heavier implements used for seeding and ground working where the wings are relatively massive and heavy. United States Patent Number 6,374,921 to Friggstad discloses an air seeder where the wings fold forward instead of rearward.

20

It is becoming more common to pull a chain of implements and carts behind one tow vehicle. For example in an air seeder there may be a cart carrying agricultural products at the front, then the air seeding implement hooked to the cart, then a fertilizer wagon

hooked to the air seeder, then perhaps a packer hooked behind the fertilizer wagon. It is not practically possible to maneuver a conventional rear fold implement from the transport to field position as described above because it is almost impossible to back up a chain of two or three implements. The system of Wilger, when adapted to a heavy
5 implement such as an air seeder or a land roller, requires a costly and cumbersome mechanism that is able to exert very high forces on the wings in order to draw them forward from transport to field position.

SUMMARY OF THE INVENTION

10

It is an object of the present invention to provide an apparatus and method for transporting an implement into a transport position and back into the field position that overcomes problems in the prior art.

15

The implement apparatus of the present invention comprises a center section mounted on main wheels oriented to carry the center section in an operating travel direction. Right and left wing sections are pivotally attached to corresponding right and left ends of the center section about substantially vertical wing pivot axes, and right and left wing wheels mounted at outer locations on the corresponding right and left wings support the wings
20 for travel in the operating travel direction. The wing wheels are pivotally mounted to the wings about substantially vertical right and left wheel axes and right and left wheel actuators are operative to pivot the right and left wing wheels about their wheel axes.

In the transport position, the wings are oriented in alignment with the operating travel direction extending rearward, and the rotational plane of each wing wheel is aligned with the corresponding wing and with the operating travel direction. When a field location is reached, the actuators are activated to pivot front edges of the wing wheels outward, such
5 that the front edge of the right wing wheel moves to the right and the front edge of the left wing wheel moves to the left. The implement is moved forward as the wing wheels pivot, and the wings are thus steered outward toward the field position. Depending on the conditions and the implement, the wings will move out through about 65 to 80 degrees by simply steering the wing wheels.

10

Wing actuators are then activated to pull the wings forward through the final 10 to 20 degrees to the full field position where the wings are perpendicular to the operating travel direction. With the wings substantially extended before any force is required by the wing actuators to complete the movement to field position, substantially less force is required
15 than would be the case where the wing actuators are required to initiate the movement of the wings from the rearward aligned transport position. The wing actuator typically will comprise a cable or like brace attached to a mid point of the wing, and a hydraulic cylinder operative to exert a force on the brace to move the wings forward. With such a configuration, and with the wings partially extended, the force exerted by the wing
20 actuator is exerted on a significant lever arm with respect to the wing pivot axis, such that the force to pivot the wing about the wing axis is reduced. In addition the wing is already moving forward along the ground, and so less force is required than would be required to start the wing from a stopped position.

By steering the wing wheels while moving forward, the wings move outward and forward toward the field position on their own, without the need to provide a mechanism with sufficient power to force the wings forward. Thus the apparatus and method allows for
5 transporting an implement where the rear folding wings have considerable size and mass without providing a costly and cumbersome mechanism for moving the wings from transport to field position.

To move from the field to transport position, the braces are released and the implement is
10 moved forward while pivoting the wheels back to their transport position with the rotational planes thereof aligned with the wings and the operating travel direction.

Since the implement is moved forward during the transition from transport to field positions, and also during the transition from field to transport position, it can be located
15 in a chain of implement where operating in a reverse direction would be problematic.

DESCRIPTION OF THE DRAWINGS

While the invention is claimed in the concluding portions hereof, preferred embodiments
20 are provided in the accompanying detailed description which may be best understood in conjunction with the accompanying diagrams where like parts in each of the several diagrams are labeled with like numbers, and where:

Fig. 1 is a schematic top view of an embodiment of an implement apparatus of the present invention in the transport position;

Fig. 2 is a schematic top view of the embodiment of Fig. 1 with the wheels partially
5 turned toward the field position;

Fig. 3 is a schematic top view of the embodiment of Fig. 1 with the wings partially extended toward the field position;

10 Fig. 4 is a schematic top view of the embodiment of Fig. 1 with the wings fully extended in the field position.

DETAILED DESCRIPTION OF THE ILLUSTRATED EMBODIMENTS

15 Figs. 1 - 4 schematically illustrate the method of the invention for transporting an implement apparatus 1. The implement wing sections 3 are schematically shown in transport position in Fig. 1, and in the full field position in Fig. 4. The implement is not illustrated in detail, and could be any kind of agricultural implement such as a sprayer or harrow drawbar, and the method is particularly suited to heavier implements such as air
20 seeders and land rollers. The illustrated implement apparatus 1 is adapted to be towed in an operating travel direction T by a tractor or the like, or could alternately be mounted directly on a vehicle.

The implement apparatus 1 comprises a center section 5 mounted on main wheels 7 oriented to carry the center section 5 in an operating travel direction T. Right and left wing sections 3 are pivotally attached to corresponding right and left ends of the center section 5 about substantially vertical wing pivot axes WA, and right and left wing wheels 9 are mounted at outer locations on the corresponding right and left wings 3 to support the wings 3 for travel in the operating travel direction T. The wing wheels 9 are pivotally mounted to the wings 3 about substantially vertical right and left wheel axes WHA and right and left wheel actuators 11 are operative to pivot the right and left wing wheels 9 about their wheel axes WHA.

10

In the transport position, illustrated in Fig. 1, the wings 3 are oriented in alignment with the operating travel direction T and extending rearward. The rotational plane of each wing wheel 9 is aligned with the corresponding wing 3 and with the operating travel direction T. When a field location is reached, the actuators 11 are activated to pivot front edges of the wing wheels 9 outward, such that the front edge of the right wing wheel 9R moves to the right and the front edge of the left wing wheel 9L moves to the left, as illustrated in Fig. 2. Fig. 2 illustrates a method of the invention where the apparatus 1 is stopped in the field and then the wheels 9 are moved to the position of Fig. 2 before the implement is moved forward. Optionally the actuators 11 can be activated while the apparatus 1 is moving forward. In that method, the wings 3 will immediately begin to move outward and forward toward the field position from the transport position.

20

In either method, the apparatus 1 is moved forward as the wing wheels 9 pivot, and the

wings 3 are thus steered outward toward the field position. Depending on the conditions and the implement, the wings 3 will typically move out through about 65 to 80 degrees to the position illustrated in Fig. 3 by simply steering the wing wheels 9 without exerting any other force on the wings 3.

5

Wing actuators 13, schematically illustrated in Fig. 3, are then activated to pull the wings 3 forward through the final 10 to 20 degrees to the full field position of Fig. 4 where the wings 3 are perpendicular to the operating travel direction T. Wheel actuators 11 pivot the wing wheels 9 to the field position of Fig. 4 where the rotational planes of the wheels 9 are oriented perpendicular to the wings 3, and aligned with the operating travel direction T.

With the wings 3 substantially extended as in Fig. 3 before any force is required by the wing actuators 13 to complete the movement to field position, substantially less force is required than would be the case where the wing actuators 13 are required to initiate the movement of the wings 3 from the rearward aligned transport position. The wing actuator 13 typically will comprise a cable 15 or like brace attached to a mid point of the wing 3, and a hydraulic cylinder 17 operative to exert a force on the brace to move the wings 3 forward. With such a configuration, and with the wings 3 partially extended, the force exerted by the wing actuator 13 is exerted on a significant lever arm L with respect to the wing pivot axis WA, such that the force to pivot the wing 3 about the wing axis WA is reduced. In addition the wing 3 is already rolling forward along the ground, and so less force is required than would be required to start the wing 3 from a stopped

position. Once the wings are in the full field position, the cable 15 can be pinned, latched, or otherwise fastened to maintain the wings 3 in the field position and relieve force on the hydraulic cylinder 17.

5 By steering the wing wheels 9 while moving forward, the wings 3 move outward and forward toward the field position on their own, without the need to provide a mechanism with sufficient power to force the wings forward. Thus the apparatus and method allows for transporting an implement where the rear folding wings 3 have considerable size and mass without providing a costly and cumbersome mechanism for moving the wings from
10 transport to field position.

To move from the field to transport position, the wing actuator 13 is released braces are released and the implement apparatus 1 is moved forward while pivoting the wheels 9 back to their transport position with the rotational planes thereof aligned with the wings 3
15 and the operating travel direction T.

The foregoing is considered as illustrative only of the principles of the invention. Further, since numerous changes and modifications will readily occur to those skilled in the art, it is not desired to limit the invention to the exact construction and operation
20 shown and described, and accordingly, all such suitable changes or modifications in structure or operation which may be resorted to are intended to fall within the scope of the claimed invention.

CLAIMS

What is claimed is:

1. An agricultural implement apparatus comprising:

a center section mounted on main wheels oriented to carry the center section in an operating travel direction;

right and left wings pivotally attached to corresponding right and left ends of the center section about substantially vertical wing pivot axes;

right and left wing wheels mounted at outer locations on the corresponding right and left wings operative to support the wings for travel in the operating travel direction;

wherein the wing wheels are pivotally mounted to the wings about substantially vertical right and left wheel axes;

wherein the wings can pivot from a transport position, where the wings extend rearward from ends of the center section and are oriented substantially in alignment with the operating travel direction and where a rotational plane of each wing wheel is substantially aligned with the corresponding wing section and with the operating travel direction, to a field position where the wings extend laterally from ends of the center section and where a rotational plane of each wing wheel is aligned with the operating travel direction;

a right wheel actuator operative to pivot the right wing wheel from the transport position to the field position as the apparatus moves in the operating travel direction by pivoting the right wheel about the right wheel axis such that a front edge of the right wheel moves to the right; and

a left wheel actuator operative to pivot the left wing wheel from the transport position to the field position as the apparatus moves in the operating travel direction by pivoting the left wheel about the left wheel axis such that a front edge of the left wheel moves to the left.

2. The apparatus of claim 1 where, in the field position, the wings extend laterally from ends of the center section substantially perpendicular to the operating travel direction.
3. The apparatus of claim 2 further comprising wing actuators operative to pull the wings forward.
4. The apparatus of claim 3 comprising releasable fasteners operative to maintain the wings in the field position.
5. A method of operating an agricultural implement, the method comprising:

providing an agricultural implement including:

a center section mounted on main wheels oriented to carry the center section in an operating travel direction;

right and left wings pivotally attached to corresponding right and left ends of the center section about substantially vertical wing pivot axes;

right and left wing wheels mounted at outer locations on the corresponding right and left wings operative to support the wings for travel in the operating travel direction;

wherein the wing wheels are pivotally mounted to the wings about substantially vertical right and left wheel axes; and

right and left wheel actuators operative to pivot the right and left wing wheels about their respective wheel axes;

orienting the wings in a transport position where the wings extend rearward from ends of the center section and are oriented substantially in alignment with the operating travel direction, and where a rotational plane of each wing wheel is substantially aligned with the corresponding wing section and with the operating travel direction;

with a tow vehicle connected to the center section, towing the implement to a field location;

towing the implement in the operating travel direction while operating the right wheel actuator to move a front edge of the right wing wheel to the right and operating the left wheel actuator to move a front edge of the left wing wheel to the left such that the wings move outward to a field position where the wings extend laterally from ends of the center section and where a rotational plane of each wing wheel is aligned with the operating travel direction.

6. The method of claim 5 wherein the wings in the field position extend laterally from ends of the center section substantially perpendicular to the operating travel direction.
7. The method of claim 6 wherein the agricultural implement comprises wing actuators operative to pull the wings forward.
8. The method of any one of claims 5 - 7 comprising fastening the wings in the field position.

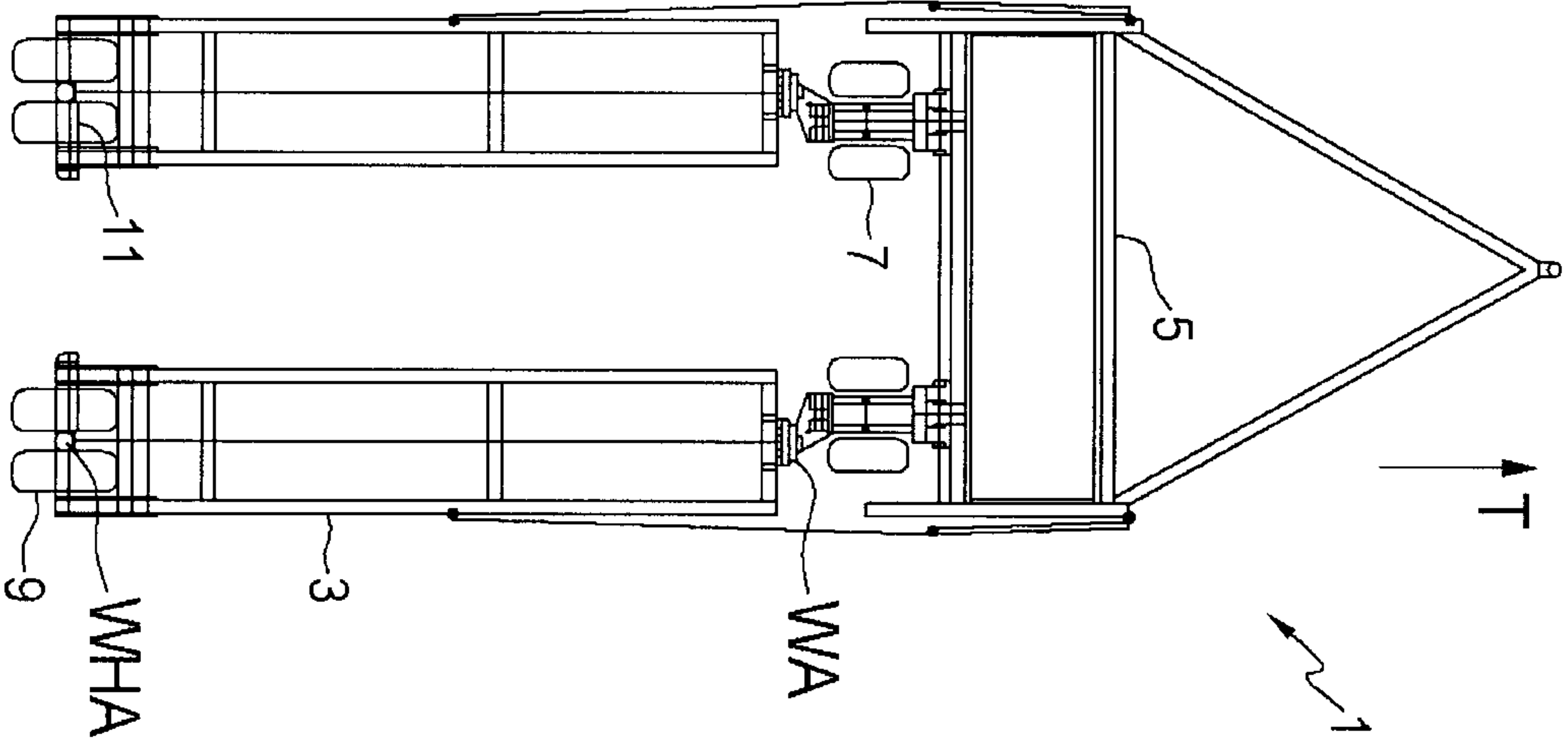

FIG. 1

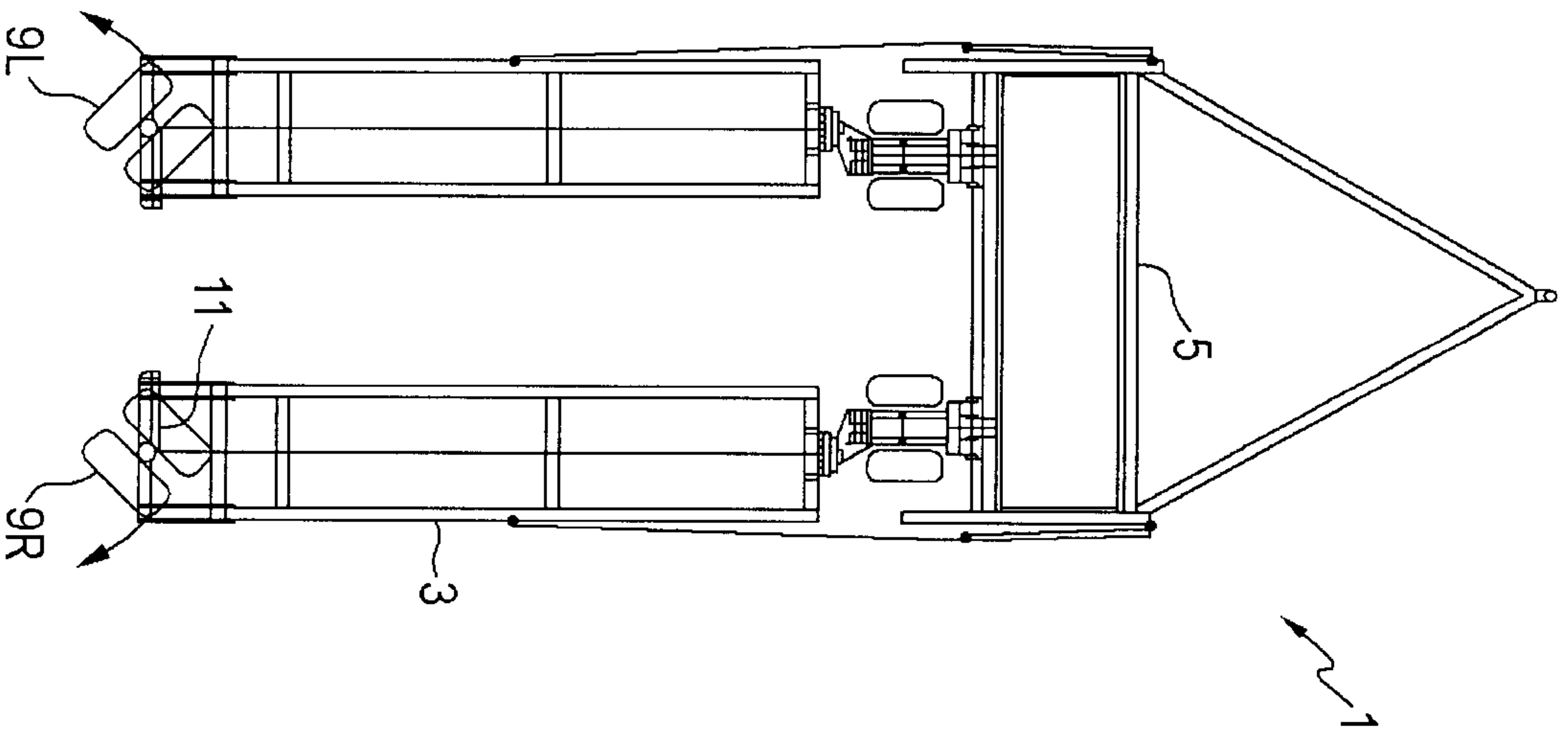

FIG. 2

