

No. 647,434.

Patented Apr. 10, 1900.

R. E. BALL.
ELECTRIC ARC LAMP.

(Application filed May 22, 1899.)

(No Model.)

2 Sheets—Sheet 1.

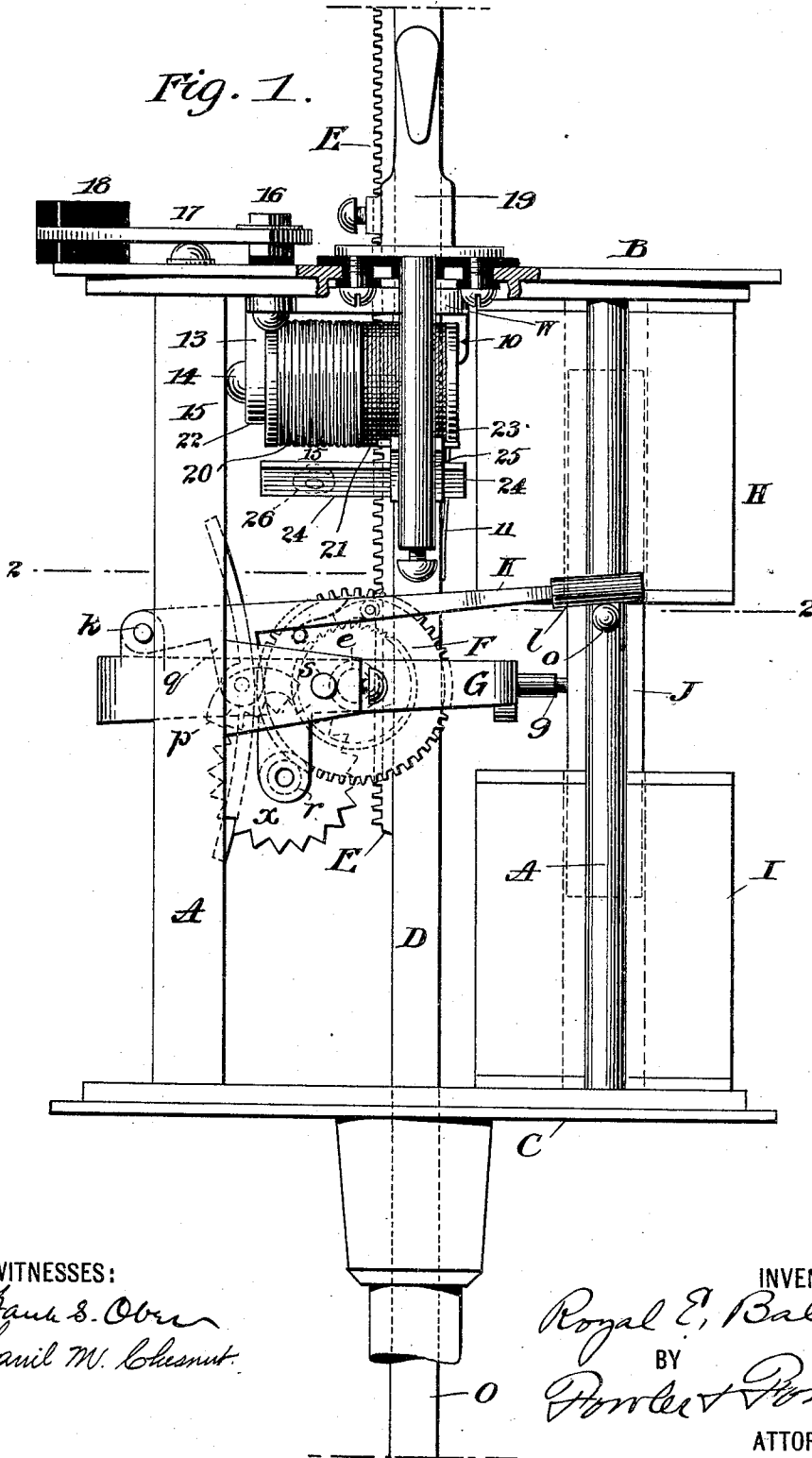

R. E. BALL.
ELECTRIC ARC LAMP.

(Application filed May 22, 1899.)

(No Model.)

2 Sheets—Sheet 2.

Fig. 2.

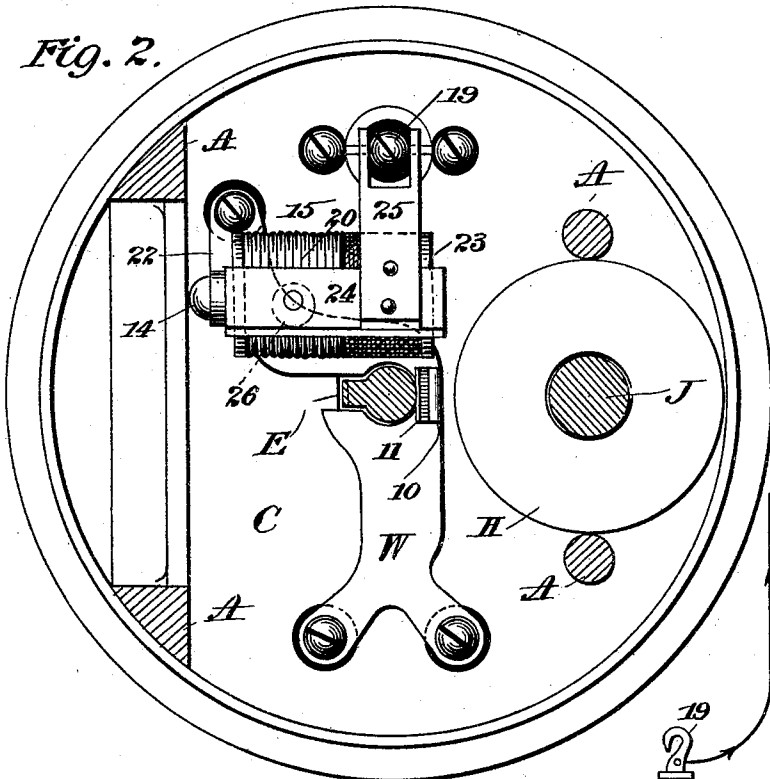

Fig. 3.

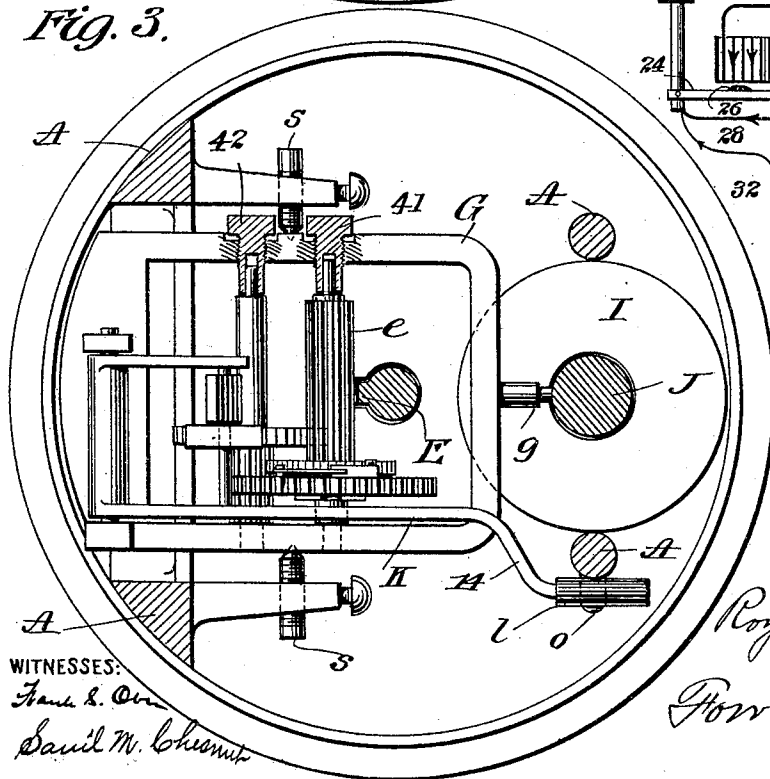
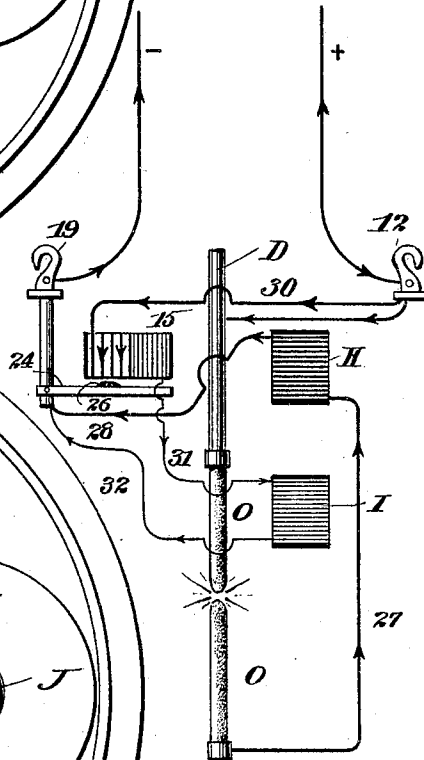

Fig. 4.



WITNESSES:

James L. Owen
David M. Chasmit

INVENTOR
Royal E. Ball,
BY
Powell & Powell
ATTORNEYS

UNITED STATES PATENT OFFICE.

ROYAL E. BALL, OF NEW YORK, N. Y., ASSIGNOR TO THE BALL ELECTRIC COMPANY, OF YONKERS, NEW YORK.

ELECTRIC-ARC LAMP.

SPECIFICATION forming part of Letters Patent No. 647,434, dated April 10, 1900.

Application filed May 22, 1899. Serial No. 717,690. (No model.)

To all whom it may concern:

Be it known that I, ROYAL E. BALL, a citizen of the United States, residing at New York, borough of Manhattan, county and State of New York, have invented certain new and useful Improvements in Electric-Arc Lamps, of which the following is such a full, clear, and exact description as will enable any one skilled in the art to which it appertains to make and use the same, reference being had to the accompanying drawings, forming part of this specification.

My invention relates to improvements in electric-arc lamps; and its object is to provide means whereby the cost of lamps of this class is reduced and their durability and efficiency maintained or increased.

In carrying out my invention I have given several functions to certain parts of the apparatus, and have thus improved the simplicity of the structure, besides accomplishing the objects already set forth.

My invention will be clearly understood by reference to the accompanying drawings, in which—

Figure 1 is a side elevation of one of my improved arc-lamps. Fig. 2 is a cross-section of my lamp along the line 2 2 in Fig. 1 looking upward. Fig. 3 is a cross-section of my lamp along the same line looking downward; and Fig. 4 is a diagram of the lamp-circuits.

In the drawings, A represents the main frame of the lamp, and B and C are the top and bottom thereof, respectively.

D is the carbon-rod, carrying the usual rack-bar E and controlled by gearing F, mounted in a tilting frame G.

The main controlling-magnet is shown at H and a shunt-magnet at I. The said magnets act differentially in a manner well understood upon a suitable core J, which projects into the interior of both the magnets. To one end of the tilting frame G is secured an insulated rod *g*, which is formed to enter an opening in the core J, the size of the opening being such with respect to the rod *g* that the latter has some play within the opening. The tilting frame G is tilted centrally at *s*, and has the controlling-gear of the lamp mounted in it, this gear consisting, essentially, of a rack-

drum *e* (adapted to engage with the rack-bar E) and clock mechanism connected with the said rack-drum, this clock mechanism being under the control of escapement-wheel *x* and a dog *p*, cooperating therewith. The escapement devices are themselves under the control of a lever K, one end of which is pivoted to the tilting frame at *k*, while the other end is protected by an insulating sleeve or collar *l* or otherwise insulated from the frame of the apparatus. In the structure illustrated the sleeve *l* is arranged so as to rest upon a screw-stop which enters one of the posts of the frame A, but projects far enough to form a rest for the said sleeve.

When the lamp is in action and the current is passing freely through the main magnet H, the core J is pulled up to a considerable extent and the controlling-gearing or feeding mechanism is prevented from moving by the escapement mechanism. When, however, the arc becomes too long or for any other reason an abnormal resistance is introduced in the main circuit, the core J moves downward and the feeding mechanism connected with the tilting frame G is allowed to move a little, so as to feed the carbon-rod D downward. This release of the feeding mechanism is brought about by the fact that the carrying down of the inner end of the tilting frame G moves the escapement-wheel *x* out of engagement with the dog *p*, whereupon the said feeding devices will begin to rotate by reason of the weight of the carbon-rod D and the upper carbon O, connected therewith.

It will be observed that the dog *p* is supported by extensions *q q* upon the arm K, while the escapement-wheel *x* is journaled between two arms *r r*, projecting downward from the frame G. It will further be observed that gravity alone is the impelling force which causes the descent of the upper carbon with its rod, no positive device being present in the so-called "feeding mechanism" for causing such descent.

Underneath the top B of my lamp I place a metallic piece W, the shape of which can best be seen in Fig. 2 of the drawings. This piece of metal has an opening at *w*, which is of substantially the same shape as the carbon-rod D, with its rack-bar E. Consequently

the part W constitutes a guide for the carbon-rod. Moreover, to this piece W is secured a little clip 10, within which is supported one or more strips of copper 11, which bear against one side of the carbon-rod D, and thus make good electrical connection between the said rod and the part W. It should be stated that the said part W is well insulated from the top B of the lamp. The said part is, however, in electrical connection with a binding-post 12 on the top of the lamp, from which it follows that this piece, together with the clip 10 and contact-strips 11, conveys the current from the said binding-post to the carbon-rod. The said piece also supports, by means of an arm 13, depending therefrom, and a suitable screw 14, the ordinary cut-out magnet 15. Besides this the usual switch-post 16 on the lamp-top is electrically connected through the said top to the piece W, so that when the switch-arm 17, pivoted to the said post, (and provided with a suitable insulating-handle 18,) is thrown around against the binding-post 19, where the current takes exit from the lamp, the said lamp will be switched out of the main circuit.

The magnet 15, forming the automatic cut-out, is an iron spool wound at one end with a coil of coarse wire 20, as shown, and at the other end with a coil 21 of fine wire, the two windings being in series upon the central bobbin and the windings being so that current goes around them in the same direction. The magnet 15 thus wound is adapted when energized to magnetize poles 22 and 23 at the opposite ends of the bobbin and to draw toward the said poles a keeper or armature 24, which is mounted upon the armature-lever 25. The latter, as shown in Fig. 2, is pivoted without insulation to an extension of the binding-post 19. In winding the magnet 15 I lay bare the outside layer of the coarse-wire coil and place it in the path of the armature 24, so that it will be struck by the said armature or, say, by a metallic button 26 on the said armature.

Referring now to the diagram, Fig. 4, it will be seen that the binding-post 12 is connected to the carbon-rod D, the mode of connection being in general through the metallic piece W, as has already been described. The main circuit passes when the lamp is in action through the said carbon-rod D, the carbons O and O', wire 27, main magnet H, wire 28, and binding-post 19 to line; but the binding-post 12 is also connected by a wire 30 with the magnet 15, passing first through the coarse-wire coils thereof and thence through the fine-wire coils by wire 31 to the shunt-magnet I, whence it goes by way of wire 32 to the binding-post 19 and to line. Should the condition arise in which too much current passes through the shunt-circuit, (and only then,) the magnet 15 attracts its armature and the said armature or the button 26 is brought into contact with the bare coarse wire of the magnet 15, whereby a circuit is

completed from one side of the lamp to the other by way of wire 30, coarse wire 20, button 26, armature 24, armature-lever 25, and post 19. Thus the lamp is provided with an automatic cut-out of the simplest construction, while the action of the parts as a whole is delicate and efficient.

The tilting frame G, carrying the controlling-gearing, is cast solid in one piece from cheap metal in a suitable mold and is journaled on the screws *s s*, set through a fixed part of the frame and having conical ends which fit into correspondingly-shaped sockets in the side of the frame. The shaft of the cog-drum *e* has one end formed cone-shaped and resting on a socket on the inner side of the frame G, while the other end of this shaft is formed with a conical socket, into which it takes the conical end of a hollow screw 41, which is set through the opposite side of the frame G. The shaft of the escapement-wheel *x* is journaled in a similar way, having also one end supported by a hollow screw 42, which is passed through the side of the frame G. I use the hollow screws for this purpose in order to lighten the weight of the mechanism and reduce the cost of the same.

By making the outer layer of coarse wire bare and making it one of the contacts of the automatic cut-out I make it possible to shift the points of contact, in case of dirt, wear, or corrosion from sparking, by simply turning the coil around, so as to bring a new portion thereof into line with the armature 24 or the button 26.

In winding the coarse wire, it is important that it be wound in proper direction, so that when armature 25 24 26 closes and makes contact the main current will flow through the coarse wire and around the magnet in the same direction as the shunt-current was flowing through the fine wire and around the magnet. This is to prevent reversal of polarity of the magnet at the time of making contact with its partial releasing and sparking effect.

Having thus described my invention, I claim—

1. In an electric-arc lamp an automatic cut-out in the shunt-circuit, the said automatic cut-out being provided with adjacent coils of coarse and fine wire, the outer layer of the said coarse wire being bare and located in the path of the magnet-armature, the latter being connected with the outgoing binding-post, substantially as and for the purpose set forth.

2. The combination of a cut-out magnet having a portion of the exterior of its outer coils bared for electric contact, said coils being adjustable angularly to shift the said contact-surface, and a circuit-completer adapted to make contact with the bared portion of said coils, substantially as and for the purpose set forth.

3. The combination of a cut-out magnet having its armature provided with a contact and acting as a circuit-completer, a portion of the exterior of the outer coils of said mag-

net being bared for electric contact with said contact on the armature, substantially as and for the purpose set forth.

4. The combination of a cut-out magnet 5 comprising a metallic spool having a coarse and a shunt coil wound thereon in series so that the main current and the shunt flow around the magnet in the same direction, a portion of the exterior of the outer coils of the 10 coarse winding being made bare for electrical contact, the said armature of the magnet being acted upon by the ends of the spool and provided with a contact for making contact with the bared portion of the coarse winding, 15 substantially as and for the purpose set forth.

5. The combination of the top and bottom plates suitably secured together for containing the working parts of the lamp, a reciprocating carbon-rod and feeding mechanism 20 therefor, an automatic cut-out provided with a magnet, an insulated bracket mounted upon the under side of said top plate and electrically connected with one of the binding-posts, said bracket being provided with a guide for 25 the carbon-rod and having a brush-carrier provided with a contact-brush for the carbon-rod, the said cut-out magnet being mounted upon and supported by said bracket, substantially as and for the purpose set forth. 30

6. The combination of the top and bottom plates suitably secured together for containing the working parts of the lamp, a reciprocating

carbon-rod and feeding mechanism therefor, an automatic cut-out provided with a magnet, an insulated metallic bracket 35 mounted upon the under side of said top plate and electrically connected with one of the binding-posts, said bracket being provided with a guide for the carbon-rod and having a brush-carrier with a contact-brush for the 40 carbon-rod, the said cut-out magnet being mounted upon and supported by said bracket, and a hand-operated cut-out switch having the post thereof electrically connected with said metallic bracket, substantially as and 45 for the purpose set forth.

7. The combination of a carbon-rod, feeding mechanism comprising a solenoid and its core, a train of wheels and a trip device for releasing the train, a suitably-mounted tilting 50 frame made in one piece of metal and connected with and operated by the said core of the solenoid, and said tilting frame having mounted thereon and supporting all of said train of the feed-gearing and its trip device, 55 substantially as and for the purpose set forth.

In testimony whereof I have hereunto set my hand, this 25th day of April, 1899, in presence of the two subscribing witnesses.

ROYAL E. BALL.

Witnesses:

CARSON G. ARCHIBALD,
H. WILLARD JOHNSON.