

[54] **WEB TREATING APPARATUS**
 [75] Inventor: **Valentin Appenzeller, Kempen/NDRRH, Germany**
 [73] Assignee: **Edward Kusters Maschinezfabrik, Krefeld, Germany**
 [22] Filed: **Mar. 24, 1972**
 [21] Appl. No.: **237,958**

[30] **Foreign Application Priority Data**
 Aug. 7, 1971 Germany..... P 21 39 651.0

[52] **U.S. Cl.**..... **68/158, 68/175**
 [51] **Int. Cl.**..... **B05c 3/132**
 [58] **Field of Search**..... **68/158, 175, DIG. 5, 68/177; 259/102**

[56] **References Cited**
UNITED STATES PATENTS
 2,204,839 6/1940 Wedler 68/175 X
 2,732,186 1/1956 Ivarsson 259/102
 2,963,893 12/1960 Kusters 68/175

3,030,791 4/1962 Brown et al. 68/177
 3,700,404 10/1972 Janisch et al. 68/DIG. 5

FOREIGN PATENTS OR APPLICATIONS

1,311,746 10/1962 France 68/175

Primary Examiner—Harvey C. Hornsby
Assistant Examiner—Philip R. Coe
Attorney—Charles B. Spencer et al.

[57] **ABSTRACT**

A treating apparatus for continuously traveling webs, such as textile webs being washed, has a drum about which the web is partially wrapped while immersed in a liquid and which is radially oscillated through an eccentric drive which is rigid in a radial direction to impart the radial oscillation to the drum and which in addition drives the drum variably frictionally in a rotational direction to force the drum to rotate at a peripheral speed which may be adjusted to correspond to the traveling speed of the web.

10 Claims, 4 Drawing Figures

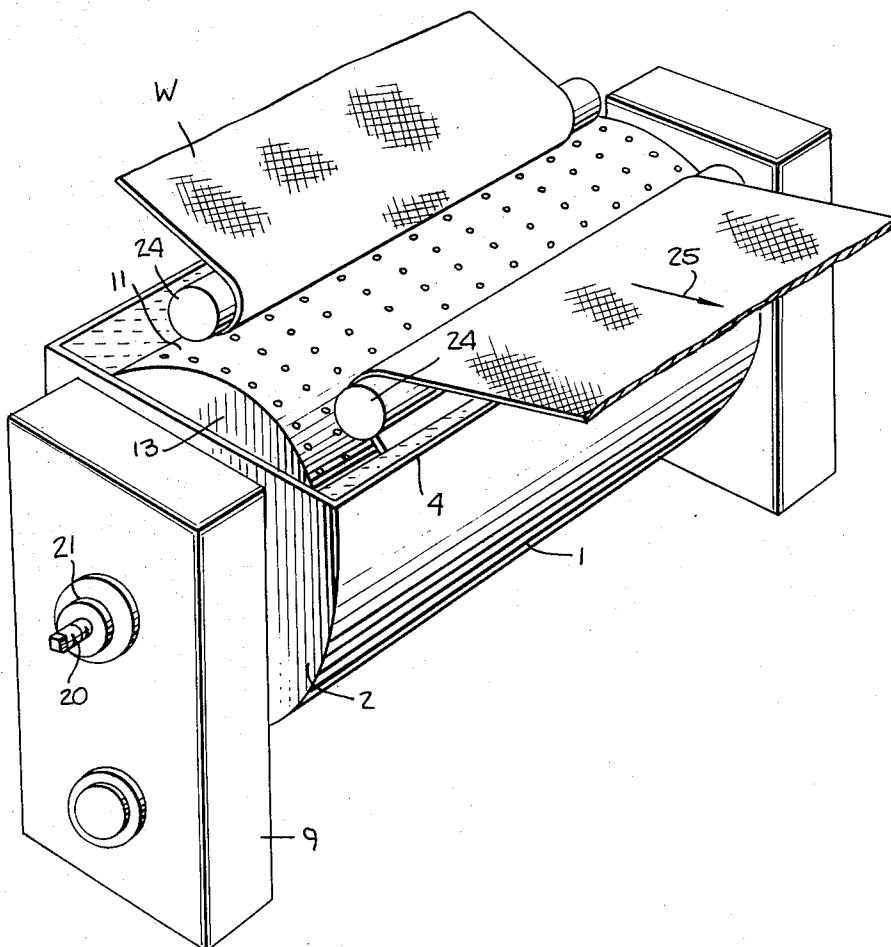

Fig. 1.

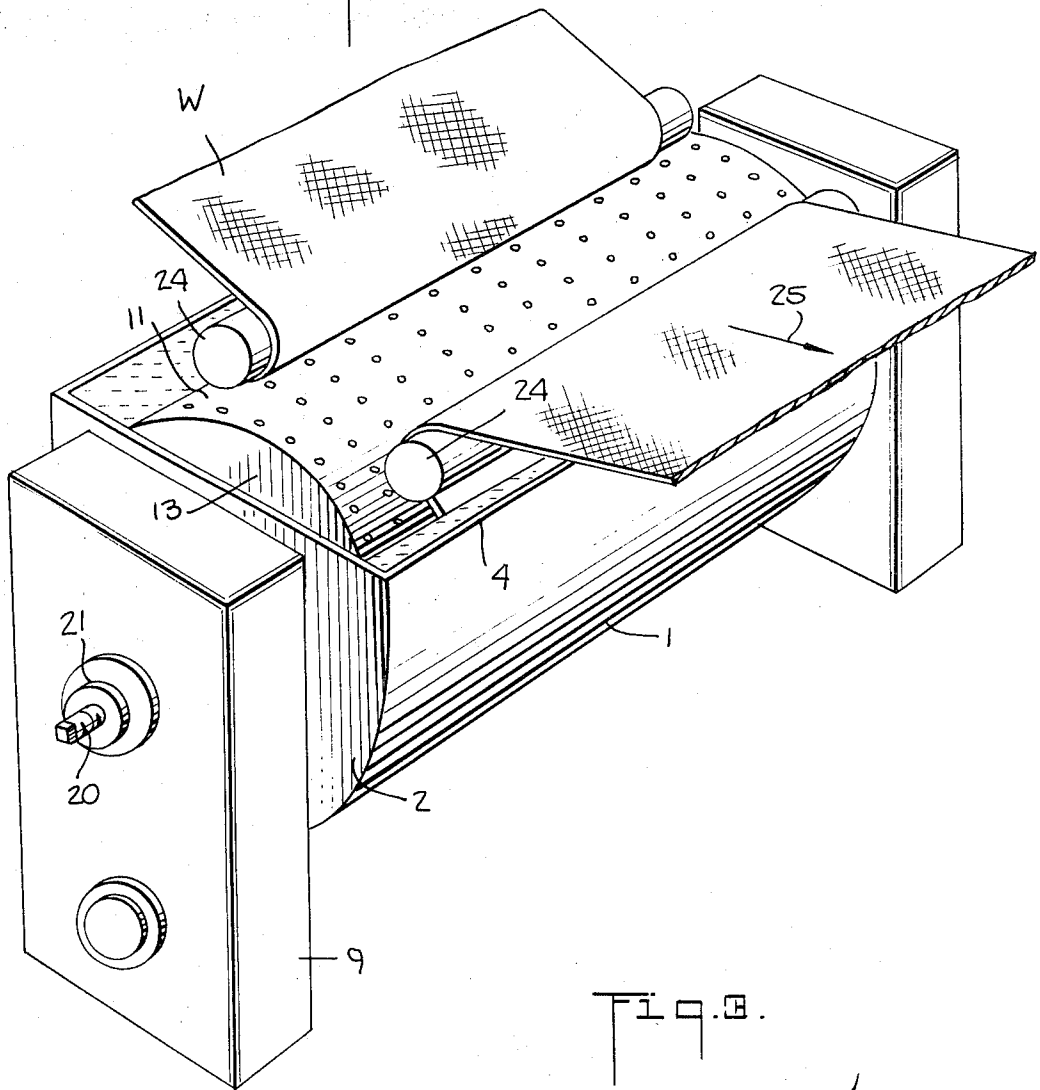
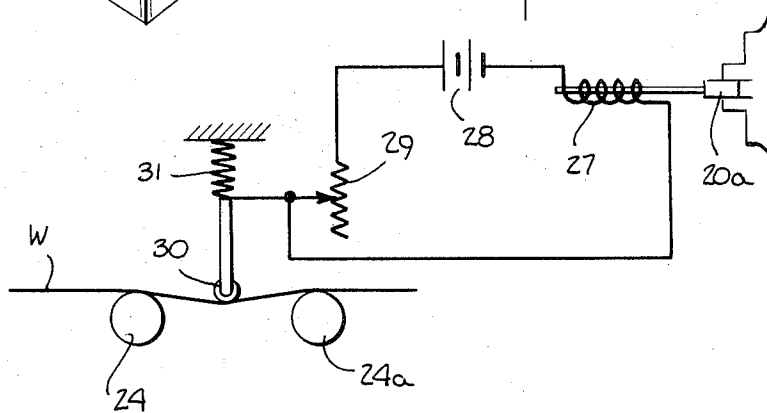
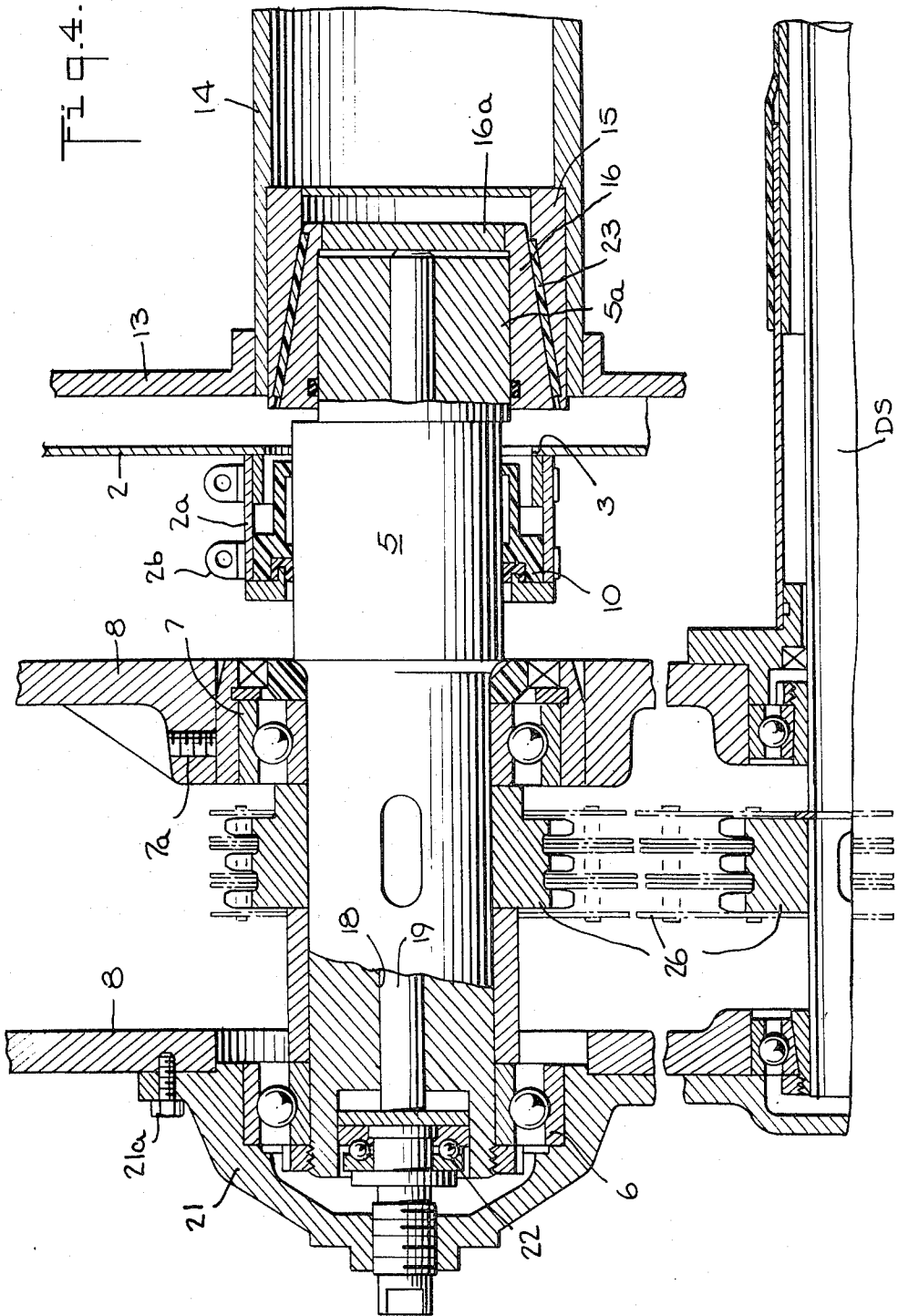

Fig. 2.





WEB TREATING APPARATUS

This invention relates to a traveling web treating apparatus having a horizontal drum which rotates in a liquid bath container containing liquid at a level above the axis of the drum, the web being partly wrapped around the drum for immersion in the liquid, and the drum being rotative while being radially oscillated at a frequency sufficiently high to exert an agitating or substantially vibrating effect on the web.

An example of such an apparatus is shown by the German Patent No. 1,113,201 dated Aug. 31, 1961 wherein the drum, normally foraminous in character, has a tubular axle mounted by eccentrics fixed on a concentrically rotating shaft with these eccentrics mounting the tubular axle of the drum through antifriction bearings. In this way the continuously traveling web itself frictionally rotates the drum while the concentric shaft, which passes through the end walls of the liquid bath container below the level of the bath, is operated at rotative speeds which, through the eccentrics, agitate or vibrate the drum.

It might be possible to mount the drum concentrically on a shaft which is radially oscillated and rotatively driven by means outside of the container, but since the shaft must pass through the stationary walls of the liquid bath container below the level of the liquid, special shaft seals are necessary which are difficult to design and maintain.

In the case of certain delicate textile fabrics, and perhaps in all instances when textile webs are being treated by the apparatus, it is desirable to have a means for rotating the drum by the use of rotary power other than that effected by relying on the frictional drive the web exerts on the drum. If the drum is rotated by power other than that exerted by the traveling web, the drive should preferably be variable as to the rotative speed given the drum to avoid overdriving or underdriving the web, and any shaft which must pass through the container's walls should rotate concentrically about its axis to avoid shaft sealing difficulties.

With the foregoing in mind, the object of the present invention is to provide a simplified apparatus which avoids such sealing problems, and which will permit the drum to be driven rotatively as required for its periphery to be synchronized with the speed of the traveling web.

As a summary of the invention, it is an apparatus which includes a liquid bath container having an end wall in which an opening is formed below the level of the bath, a rotative drive shaft extending through this opening from the outside of the container to the inside, with bearing means on the outside of the container for radially rigidly mounting this drive shaft for concentric rotation and, of course, means on the outside of the container for rotatively driving this shaft but without radial oscillation motion. Since the shaft rotates simply concentrically, sealing means are easily provided for sealing the shaft fluid-tightly with respect to the opening in the container end wall. On the inside of the container the drum has the tubular axle which is parallel to the shaft, the latter and the axle having longitudinally opposed ends.

Incidentally, only one end of the drum's axle and one shaft is being described, but it is to be understood that the other end of the axle is mounted at the other end of the container by the same kind of assembly that is now being described.

The drum's axle is held parallel to the shaft by a coupling means inside of the container which eccentrically connects the two opposed ends in a manner that is substantially rigid in a radial direction so that relative rotation of the shaft produces the radial oscillation of the axle and drum, but in a rotative direction the coupling operates in the manner of a plain sliding journal and bearing assembly, as contrasted to the prior art concept of reducing friction to a minimum by the use of antifriction bearings. These bearing assemblies may be tightened and loosened as to their relatively sliding surfaces so that the degree of rotative force imparted to the drum's axle may be varied. The action is somewhat like that of a slipping clutch having its slippage controllable so that varying degrees of rotative force may be applied to the axle.

It is to be understood that the shafts at opposite ends of the container are synchronized and timed relative to each other so that the axis of the drum's axle always remains parallel to these shafts.

There are various other important details disclosed by the following description of a specific example of the invention, illustrated by the accompanying drawings in which:

FIG. 1 is a perspective view of a textile web washing apparatus embodying the features of the present invention;

FIG. 2 is a longitudinal vertical section, a part of the shaft being in elevation, showing the shaft and its journals and the coupling between this shaft and the drum's axle;

FIG. 3 in a very schematic manner illustrates how the action of the frictional drive may be made automatically responsive to the tension on the web whereby to eliminate manual adjustment of the frictional drive; and

FIG. 4 shows the parts of FIG. 3 rotated enough to illustrate the eccentricity involved.

Referring to these drawings, it is to be emphasized that FIG. 2 illustrates only the elements at the left-hand end of FIG. 1, there being a duplicate (not shown) at the right-hand end.

With the above understanding, the drawings show a liquid bath container 1 having an end wall 2 in which an opening 3 is formed below the level of this bath, the latter being indicated at 4 as being near the open top of the container 1. A rotative shaft 5 extends through the opening 3 from the outside of the container 1 to its inside. The bearing means on the outside of the container which radially rigidly mounts the shaft 5 for concentric rotation comprise interspaced antifriction bearings 6 and 7, these bearings being mounted by the interspaced walls 8 of the left-hand one of the frames 9 of the apparatus. Sealing means 10 seal the shaft 5 fluid-tightly with respect to the opening 3.

The foraminous or liquid pervious drum 11 has its end wall 13 mounted by the drum's tubular axle 14 which is on the inside of the container. The tubular axle 14 contains a conical female part 15 that is non-rotative and concentric relative to the axle 14. This end of the axle 14 is opposed to the end of the shaft 5 and the latter mounts a conical male part 16 which fits the female part 15 in a rotatively sliding manner, this male part 16 being non-rotative and eccentric relative to the shaft 5.

In more detail, the part 16 is non-rotatively connected to a stub shaft 5a which may be an integral part

of the shaft itself. The stub shaft 5a is externally cylindrical but is eccentric with respect to the balance of the shaft 5 and the conical male part 16 is axially slidable on this stub shaft 5a, a pin 17 locking the part 16 non-rotatively with respect to the stub shaft 5a, but in an axially slidable manner.

The shaft 5, including its stub shaft 5a, has an axially extending bore 18 which is concentric with respect to the axis of the shaft 5 and a push rod 19 extends through this bore with an inner end bearing against an end plate 16a of the conical male part 16, its outer end receiving variable pressure or position adjustment by a screw 20 threaded through a hole in an outer end cap 21 connected to the outer one of the walls 8. An anti-friction thrust bearing 22 is interposed between the inner end of the screw 20 and the outer end of the push rod 19 since the screw 20 is non-rotative excepting when being adjusted.

It can be seen that the conical parts 16 and 15 serve to mount the axle 14 and that in a radial direction these parts are substantially rigid so that rotation of the shaft 5 can impart the desired radial oscillation or vibration to the axle 14 and thus to the drum 11, but that rotatively the parts 15 and 16 form what is in effect a plain sliding rotary bearing. Actuation of the screw 20 to release the pressure on the two parts 15 and 16 can provide for substantially free rotation of the axle 14 relative to the shaft 5 when desired, in which case the apparatus would function more or less in the manner of the German Patent No. 1,113,201, and the use of the screw 20 to tighten the two bearing parts 15 and 16 together increases the bearing friction to apply rotative force to the axle 14 and, therefore, to the drum 11 with this force adjustable as required to reduce or eliminate any drag by the drum 11 on the traveling web. In other words, the drum rotation can be peripherally synchronized with the traveling speed of the web.

To provide smooth sliding action, a bearing liner 23 in the form of a conical cap fitting the conical part 16 is provided. The conical parts would normally be made of metal, and this bearing liner 23 when made of fiberglass reinforced plastic, particularly polytetrafluorethylene as the plastic, provides a smooth sliding action avoiding possible jerkiness or roughness on the part of the rotative force imparted to the axle 14 when the screw 20 is tightened as required to apply the proper rotative force to this axle 14 demanded by the fabric being washed or otherwise treated. The bearing parts are, of course, immersed in the liquid bath.

As shown by FIG. 1, the fabric web W is wrapped partially downwardly and around and upwardly and from the drum 11 by guiding rollers 24. With the drum 11 receiving the proper amount of rotative force, the entry and exit of this web W is smooth with the web traveling continuously although it is agitated by the radial component of the drum 11 while the web is traveling through the bath 4. The bearing liner 23 assists appreciably in promoting the smooth rotation of the drum and, therefore, the travel of the web W without the latter necessarily driving the drum 11 rotatively, although it may if desired. It is to be understood that the web W receives tension or a continuous pull in the direction of the arrow 25 to keep it traveling, in the normal use of an apparatus of the present type.

The seal assembly 10 may be designed simply because the shaft 5 rotates concentrically, and it is retained by a housing 2a fixed to the drum 2, this being

done by compression of the housing 2a through the medium of compression bands 24 which when loosened permit the sealing assembly to be moved to the left in FIG. 2. The bearings 7 are retained in position by one or more set screws 7a, for example, and the end cap 21 is fastened to the outer one of the walls 8 by screws 21a. Therefore, release of the bands 24, of the set screw or screws 7a, and the screws 21a, permit the shaft 5 to be moved to the left far enough for the conical part 16 to move outwardly through the hole 3 and permit the complete separation of the two conical parts. This permits the drum 11 to be removed from the container 1 so that the bearing liner 23 may be serviced or replaced.

As previously indicated, only the left-hand end of the apparatus of FIG. 1 is described in detail, there being a duplication at the right-hand end. The two shafts 5 at the opposite ends of the apparatus are synchronized by an interconnecting drive shaft DS which extends transversely from one side of the machine to the other and interconnects the shafts 5 for synchronized and properly timed rotation through chain drives 26. This shaft DS is driven by a suitable motor (not shown) located on the outside of the bath container or tank 1.

In FIG. 3, the screw 20 is replaced by a reciprocative plunger 20a to which pressure is applied by an electric solenoid 27 powered by a suitable source 28 of electric current and a circuit under the control of a rheostat 29. This rheostat is shown as having its movable element actuated by a roller 30 working on a span of the web W leaving the exiting one of the rollers 24 with its other span end formed by another guide roller 24a, the roller 30 being pressed into this span by a spring 31. As the span between the roller 24 and 24a tightens, the roller 30 rises and the resistance of the rheostat 29 is reduced so that the solenoid 27 through the part 20a applies greater pressure to the push rod 19, loosening of the span producing the opposite effect. In this way the frictional drive between the conical bearing parts previously described may be made automatically responsive to the tension on the web pulled from the apparatus of FIG. 1.

It is to be understood that this representation of FIG. 3 is entirely schematic and is intended only to show the principal of operation involved in providing the push rod with a remote control made automatically responsive to the tension of the web to assure that the proper driving force is frictionally applied to the drum 11 at all times.

What is claimed is:

1. An apparatus including a web treatment drum in a fluid bath container having an end wall in which an opening is formed below the level of this bath, a rotative shaft extending through said opening from the outside of said container to its inside, bearing means on the outside of said container for radially rigidly mounting said shaft for concentric rotation, means on the outside of said container for rotatively driving said shaft, sealing means for sealing said shaft fluid-tightly with respect to said opening, an axle mounting said drum and extending parallel to said shaft on the inside of said container, said shaft and axle having mutually opposed ends, and coupling means inside of said container for eccentrically interconnecting said ends substantially rigidly in a radial direction and frictionally in a rotative direction.

2. The apparatus of claim 1 in which said coupling means includes a plain sliding journal and bearing assembly formed by conical male and female parts respectively connected non-rotatively to said opposed ends with the part on one of said ends eccentric with respect thereto and the part on the other of said ends substantially concentric with the latter.

3. The apparatus of claim 2 in which one of said parts is axially movable relative to the other part and has means for variably axially positioning it relative to that other part to vary the bearing friction of said assembly.

4. The apparatus of claim 2 in which said parts have interposed between them a bearing liner made of fiberglass reinforced plastic.

5. The apparatus of claim 4 in which said plastic is polytetrafluorethylene.

6. The apparatus of claim 1 having means for varying the frictional force of said coupling means.

7. The apparatus of claim 1 in which said coupling is formed by said end of said axle mounting a conical female part that is non-rotative and concentric relative to the axle and by said end of said shaft mounting a conical male part fitting said female part in a rotatively slid-

ing manner with this male part non-rotative and eccentric relative to the shaft.

8. The apparatus of claim 7 in which said drum is mounted coaxially by said axle and has means for guiding a traveling web so it wraps partially around said drum, said male part being axially movable relative to said shaft and the latter having an axially extending bore and a push rod extending through this bore and connecting with said male part to push it towards said female part, with means positioned outside of said container for applying variable pressure to said push rod.

9. The apparatus of claim 8 in which said push rod's variable pressure applying means is remotely controllable and includes means for controlling this pressure applying means automatically in response to the tension on said web.

10. The apparatus of claim 8 in which a bearing liner is interposed between the interfitting surfaces of said conical parts, said liner being made of fiberglass reinforced plastic, said shaft and said conical male part mounted thereby being retractable outwardly so said parts may be separated to give access to said liner.

* * * * *

25

30

35

40

45

50

55

60

65