



US010465516B1

(12) **United States Patent**  
**Hilgert et al.**

(10) **Patent No.:** **US 10,465,516 B1**

(45) **Date of Patent:** **Nov. 5, 2019**

(54) **OPPOSED PISTON ENGINE CAM SHAPE**

(56) **References Cited**

(71) Applicant: **HTS LLC**, Houston, TX (US)

U.S. PATENT DOCUMENTS

(72) Inventors: **Carlos Marcelo Hilgert**, Gonçaves (BR); **Gustavo Ludwig Schneider**, Rio de Janeiro (BR)

1,788,140 A	1/1931	Woolson
1,808,083 A	6/1931	Tibbetts
1,819,826 A	8/1931	Sherman
2,076,334 A	4/1937	Burns
2,080,846 A	5/1937	Alfaro
2,457,183 A	12/1948	Sherman
2,567,576 A	9/1951	Palumbo
2,770,140 A	11/1956	Palumbo
3,456,630 A	7/1969	Karlan
3,943,895 A	3/1976	Howell
4,996,953 A	3/1991	Buck
5,031,581 A	7/1991	Powell
5,103,778 A	4/1992	Usich, Jr.
5,375,567 A	12/1994	Lowi, Jr.
5,507,253 A	4/1996	Lowi, Jr.
5,749,337 A	5/1998	Palatov

(73) Assignee: **HTS LLC**, Houston, TX (US)

(\* ) Notice: Subject to any disclaimer, the term of this patent is extended or adjusted under 35 U.S.C. 154(b) by 0 days.

(21) Appl. No.: **16/291,680**

(22) Filed: **Mar. 4, 2019**

(Continued)

**Related U.S. Application Data**

**FOREIGN PATENT DOCUMENTS**

(60) Provisional application No. 62/756,846, filed on Nov. 7, 2018, provisional application No. 62/807,084, filed on Feb. 18, 2019.

GB	2019487 A	10/1979
GB	2369859 A	6/2002

(Continued)

Primary Examiner — Grant Moubry

(51) **Int. Cl.**  
**F01B 3/00** (2006.01)  
**F02B 75/26** (2006.01)

(57) **ABSTRACT**

(52) **U.S. Cl.**  
CPC ..... **F01B 3/002** (2013.01); **F01B 3/0005** (2013.01); **F01B 3/0085** (2013.01); **F02B 75/26** (2013.01); **F01B 3/0029** (2013.01)

An opposed piston engine has a driveshaft with a spaced apart cams mounted thereon. Each cam has a circumferential cam shoulder of a curvilinear shape selected to enhance flow through intake and exhaust ports. The curvilinear shape may be a segmented polynomial shape forming lobes which lobes are asymmetrical so that the lobe wavelength distance from a first trough to the lobe peak of an ascending shoulder portion of the lobe is greater than the lobe wavelength distance from the peak to a second trough of a descending shoulder portion of the lobe. Opposing cam shoulders may be shaped so as to always be converging or diverging from one another.

(58) **Field of Classification Search**  
CPC ..... F01B 3/002; F01B 3/0085; F01B 3/0005; F01B 3/0029; F01B 3/0023; F01B 3/04; F01B 3/045; F01B 7/00; F01B 7/02; F01B 7/04; F01B 9/06; F01B 2009/061; F01B 2009/065; F02B 75/26

See application file for complete search history.

**30 Claims, 31 Drawing Sheets**

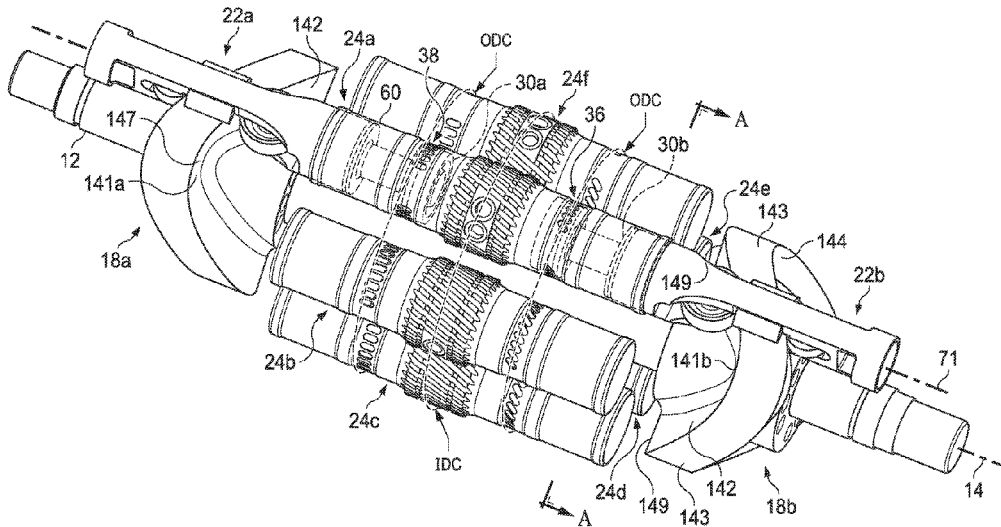

(56)

**References Cited**

U.S. PATENT DOCUMENTS

5,799,629	A	9/1998	Lowi, Jr.	
6,089,195	A	7/2000	Lowi, Jr.	
6,202,605	B1	3/2001	Henriksen	
6,250,264	B1	6/2001	Henriksen	
6,305,335	B1	10/2001	O'Toole	
6,779,494	B1	8/2004	Aswani	
6,834,636	B2	12/2004	Thomas et al.	
8,245,673	B2*	8/2012	Howell-Smith	..... F01B 1/0624 123/197.1
8,534,241	B2	9/2013	Gaiser	
8,820,275	B2*	9/2014	McAlister	..... F01B 1/062 123/47 R
8,863,643	B2	10/2014	Powell	
9,528,373	B2*	12/2016	Van Den Brink	.... F01B 3/0085
2003/0188701	A1	10/2003	Daniel	
2006/0037567	A1	2/2006	Thomas	
2008/0105117	A1	5/2008	Kubes et al.	

2008/0105222	A1*	5/2008	Kubes	..... F01B 3/0005 123/52.1
2008/0105224	A1*	5/2008	Kubes	..... F01B 3/0005 123/56.1
2009/0188471	A1*	7/2009	Jaquet	..... F01B 3/0005 123/48 B
2015/0114148	A1*	4/2015	Van Den Brink	..... F16H 53/06 74/56
2016/0025002	A1*	1/2016	Ellis	..... F01L 17/00 123/51 B

FOREIGN PATENT DOCUMENTS

GB	2453131	A	4/2009
GB	2476078	A	6/2011
GB	2482565	A	2/2012
GB	2558648	A	7/2018
WO	WO-0223025	A1	3/2002
WO	WO-2013124604	A1	8/2013

\* cited by examiner

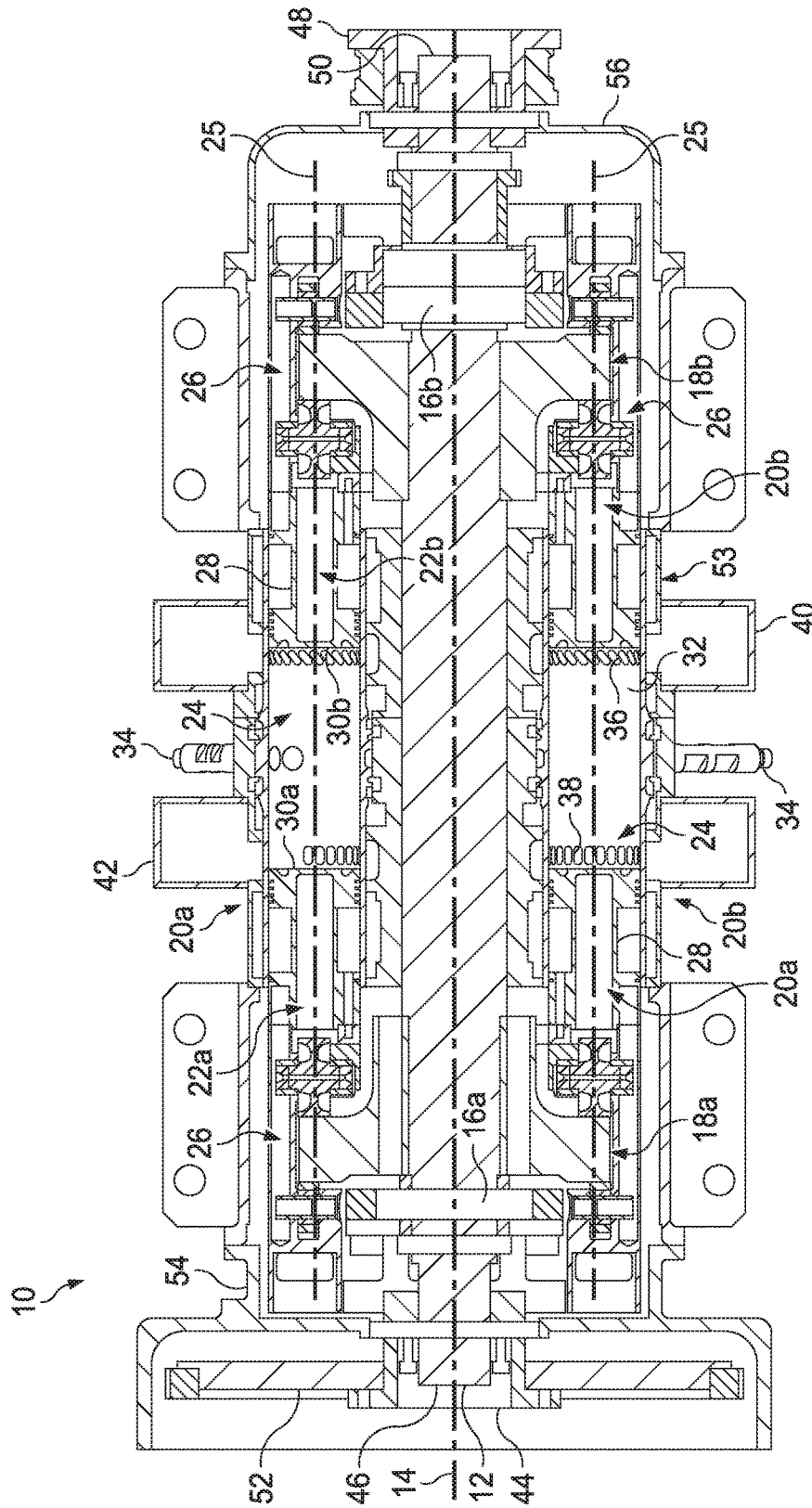

Fig. 1

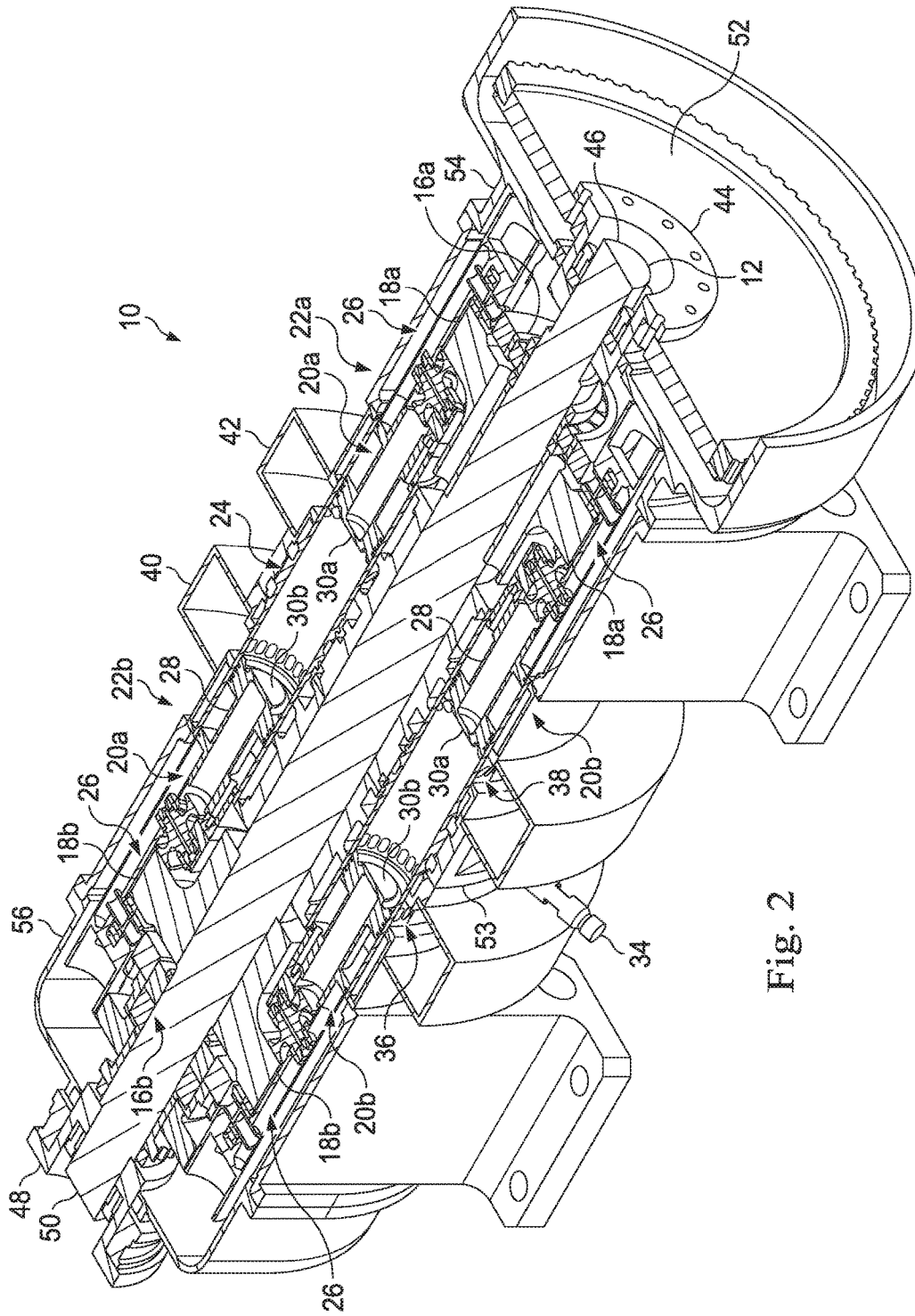

Fig. 2

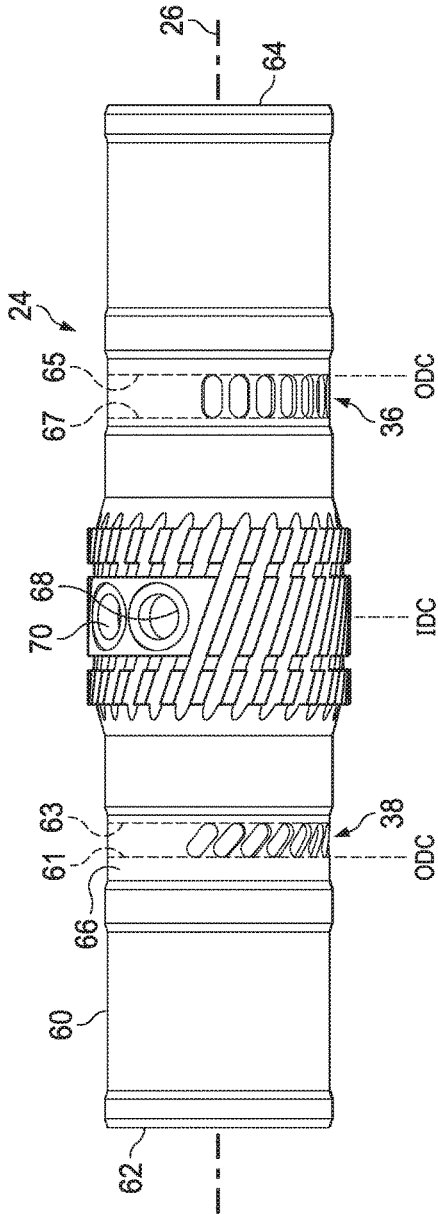

Fig. 3

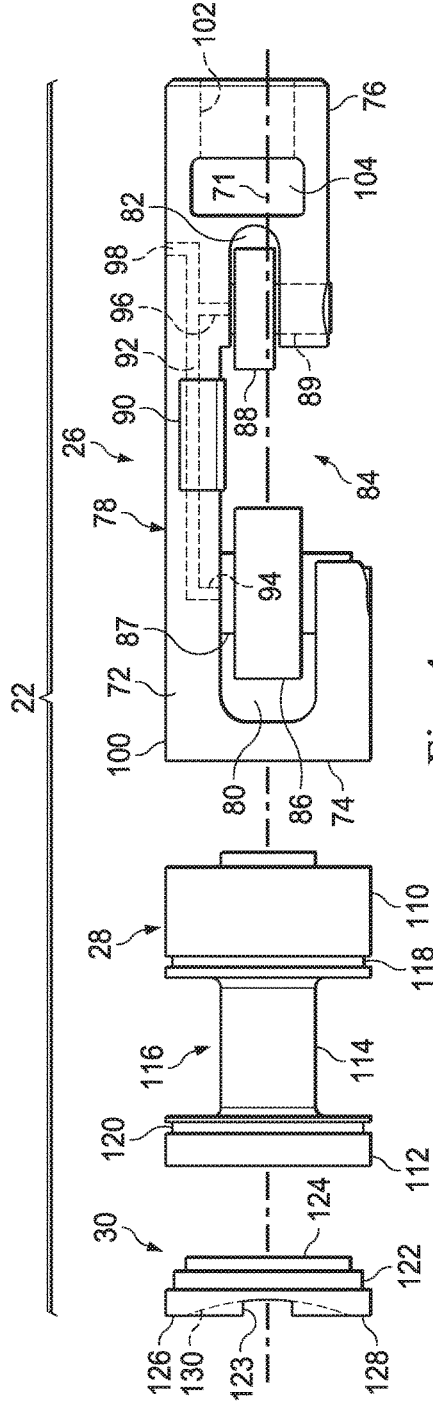

Fig. 4a

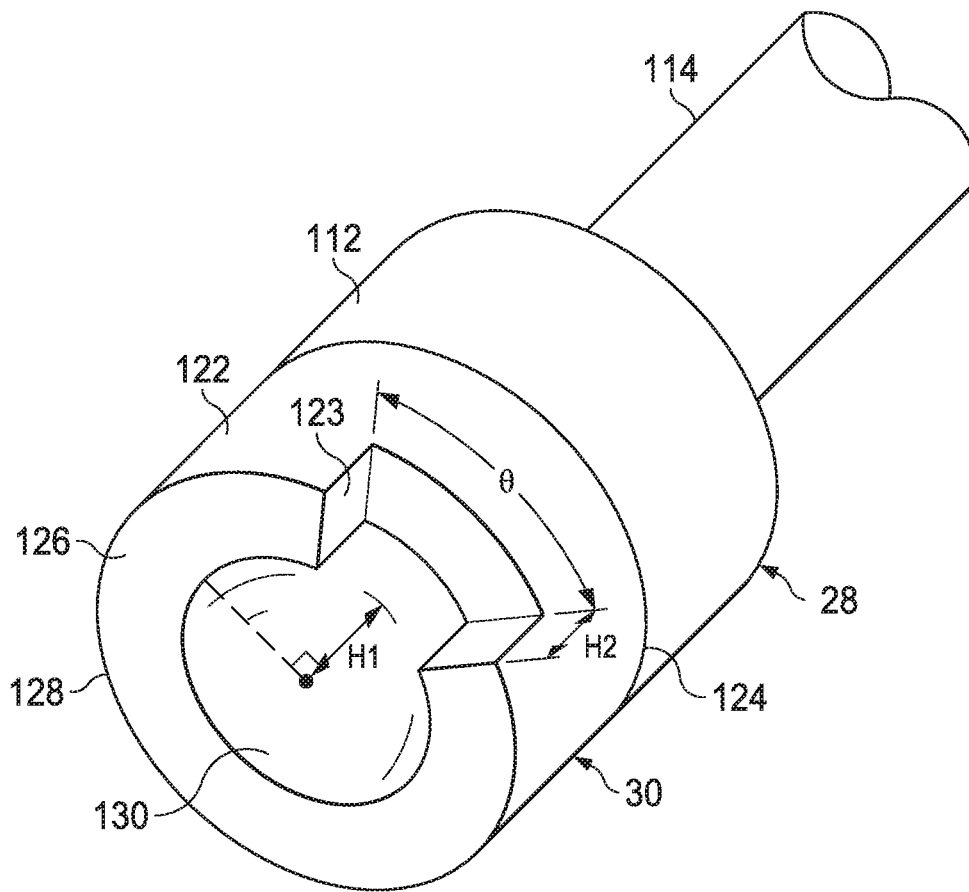

Fig. 4b

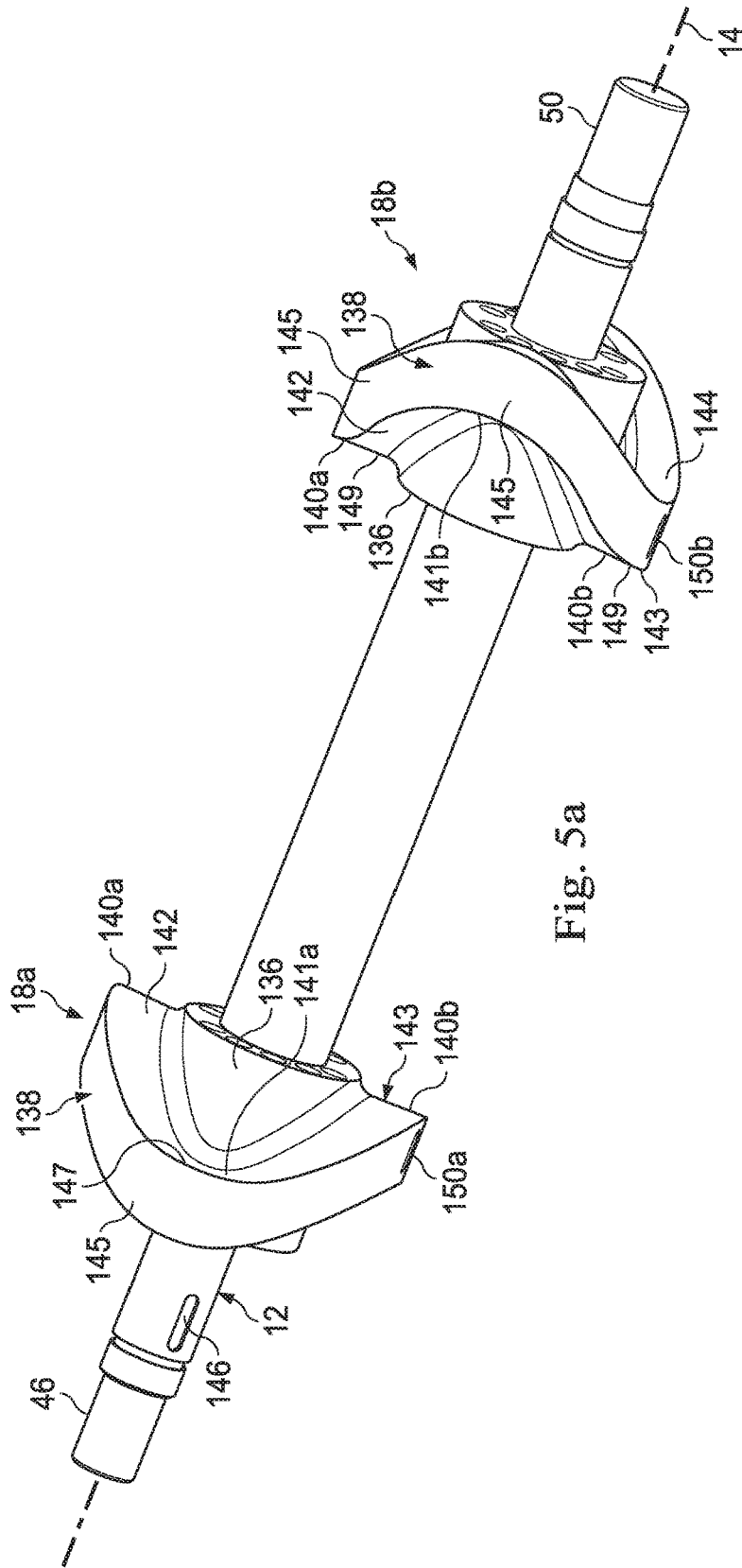

Fig. 5a

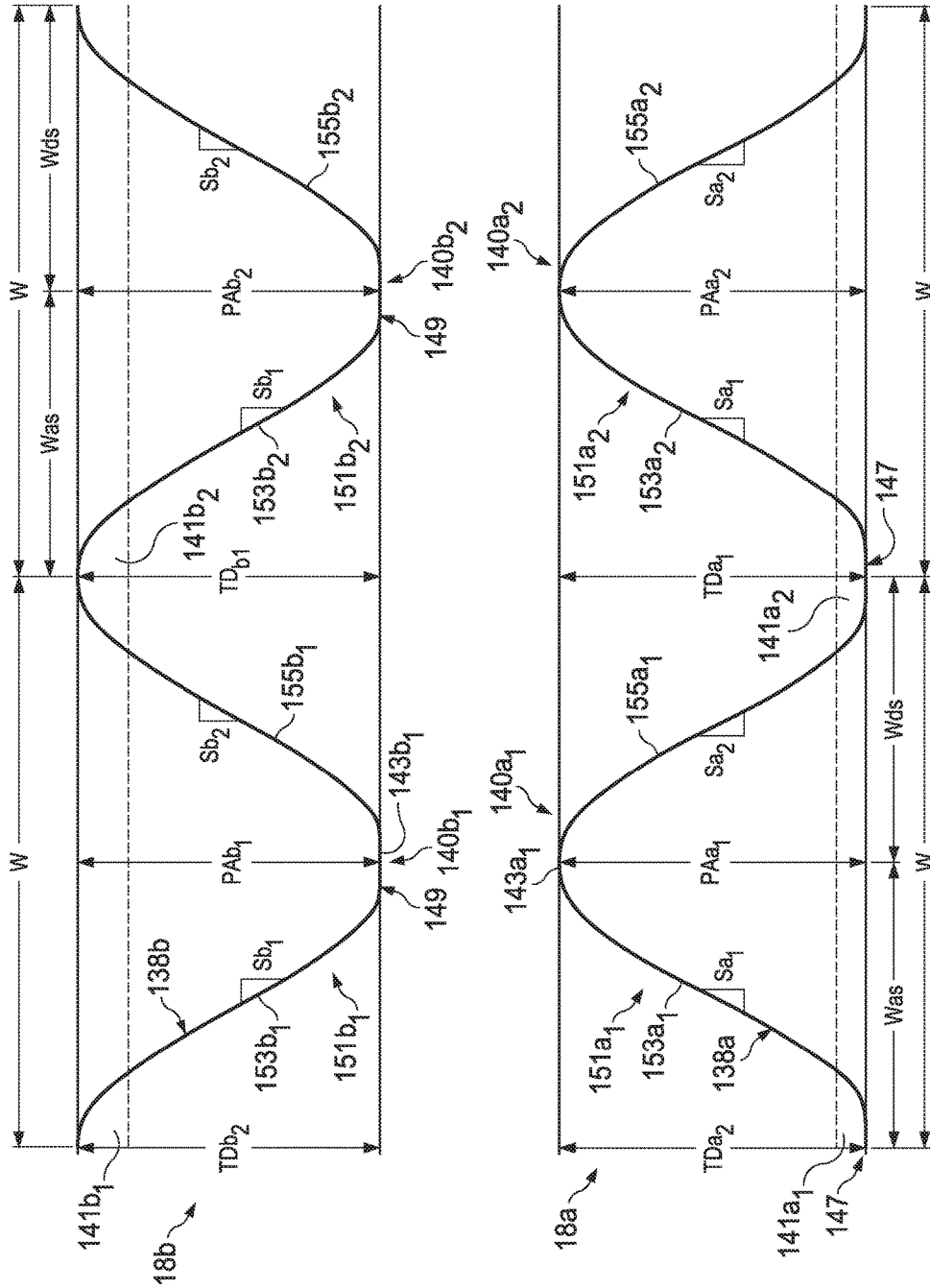

Fig. 5b

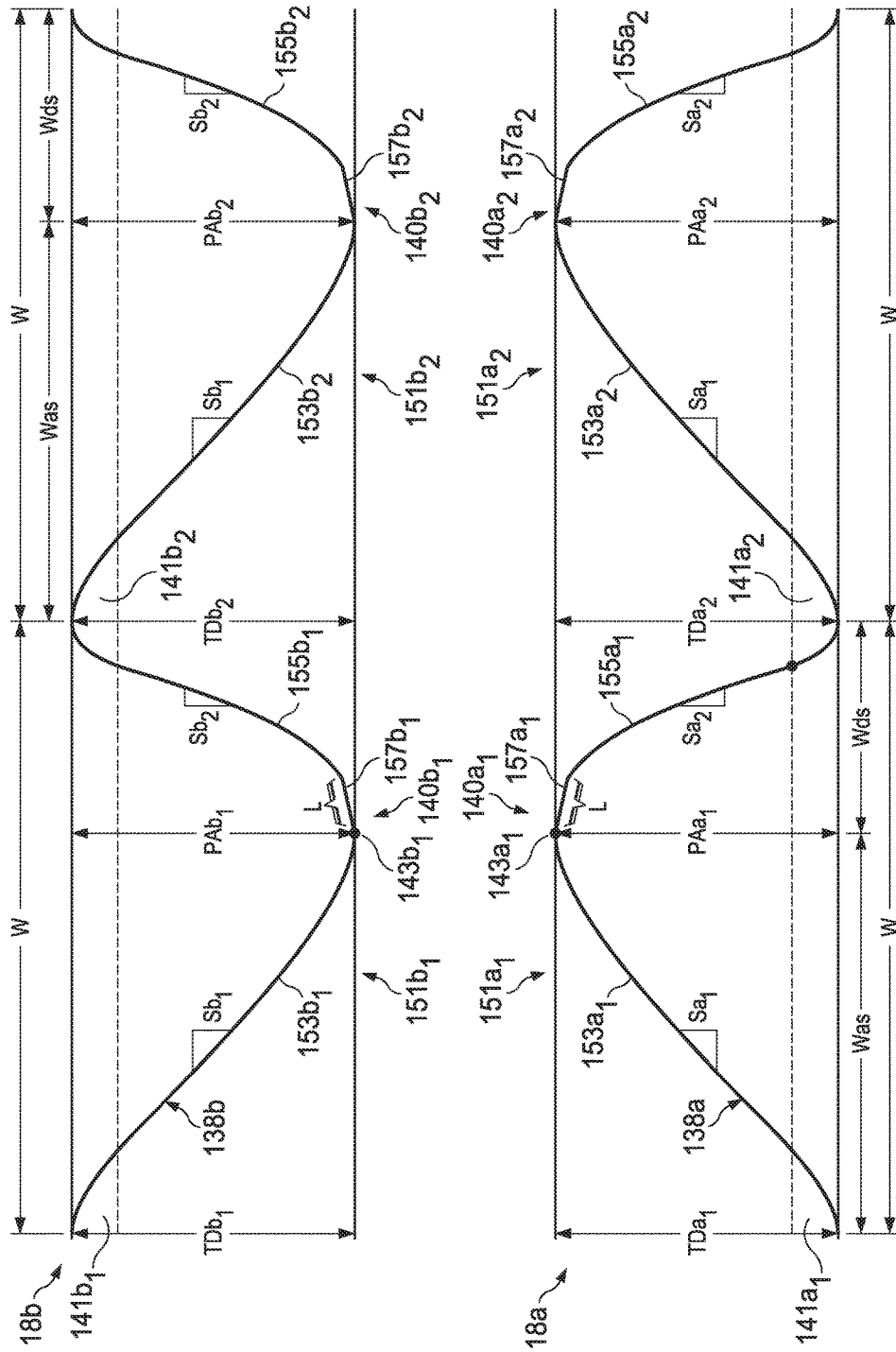

Fig. 5c

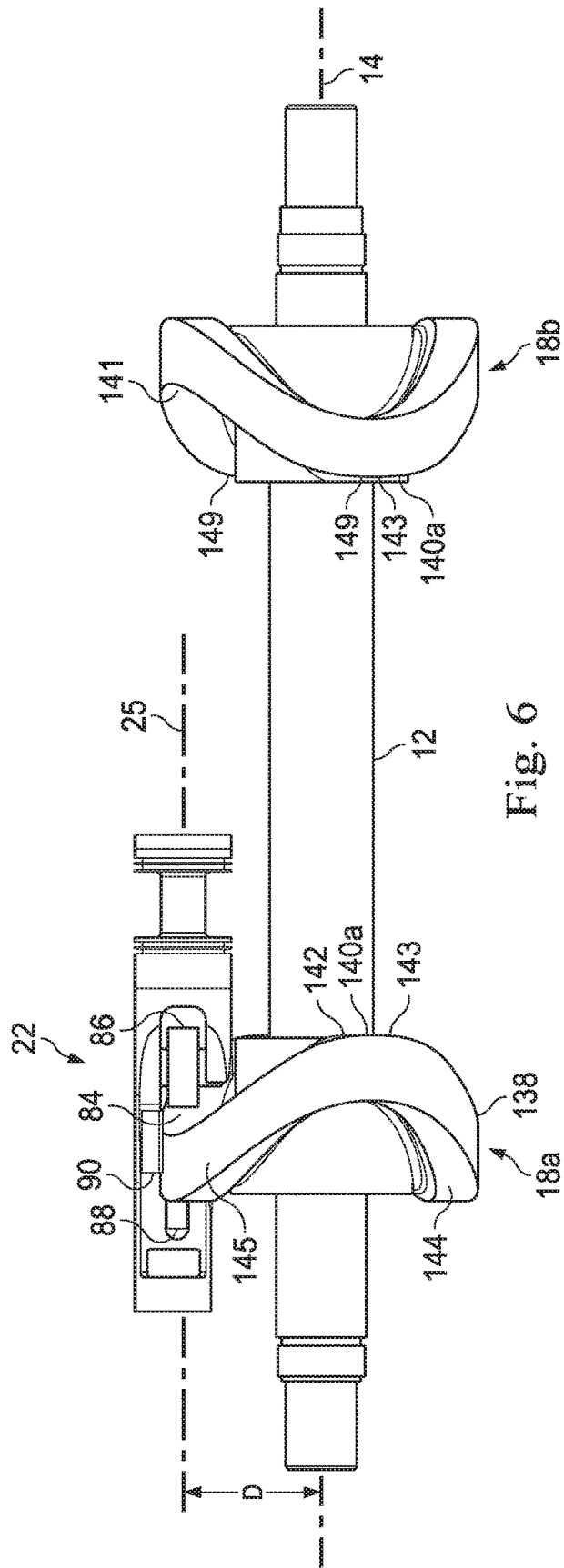

Fig. 6

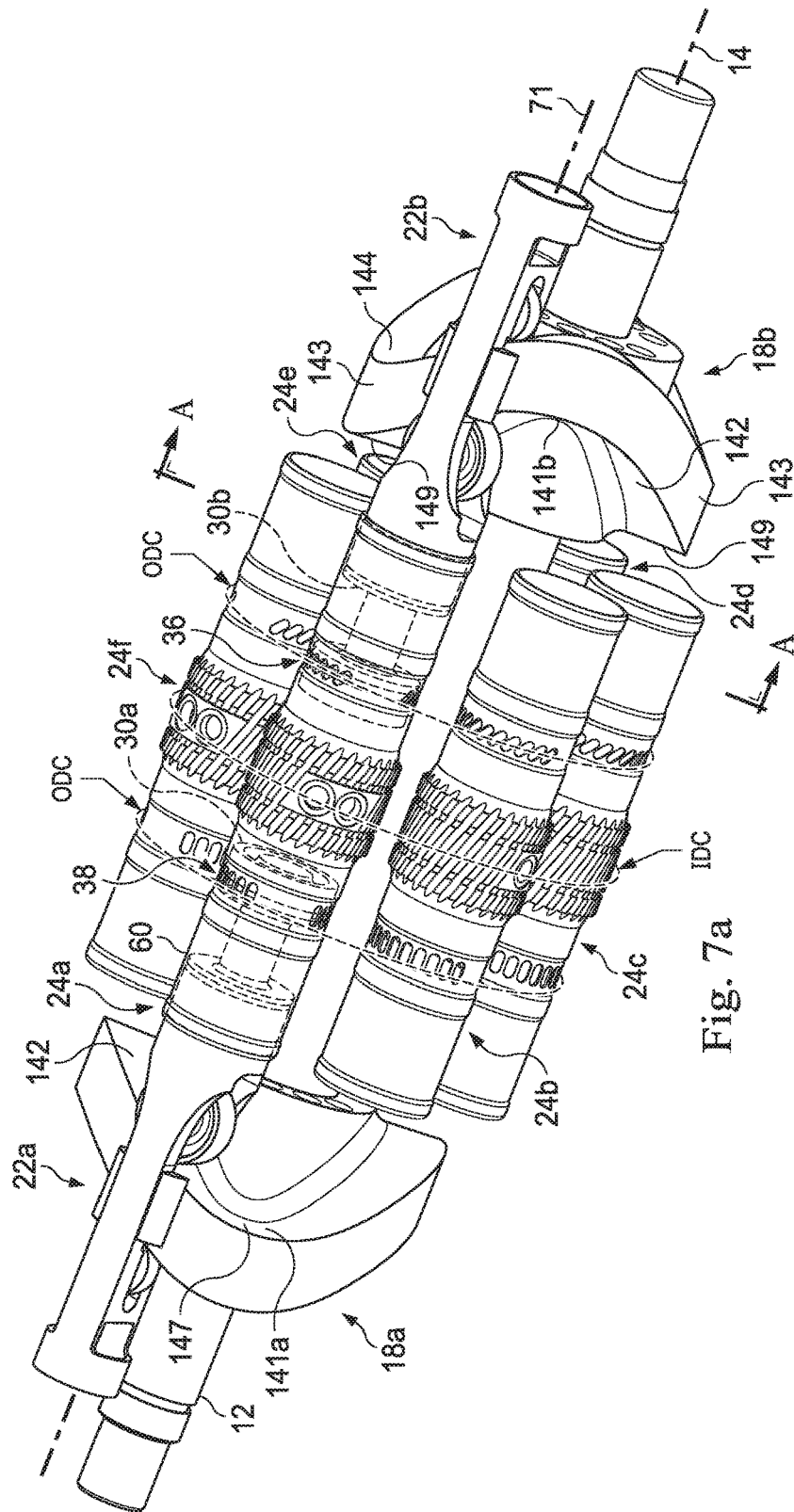

Fig. 7a

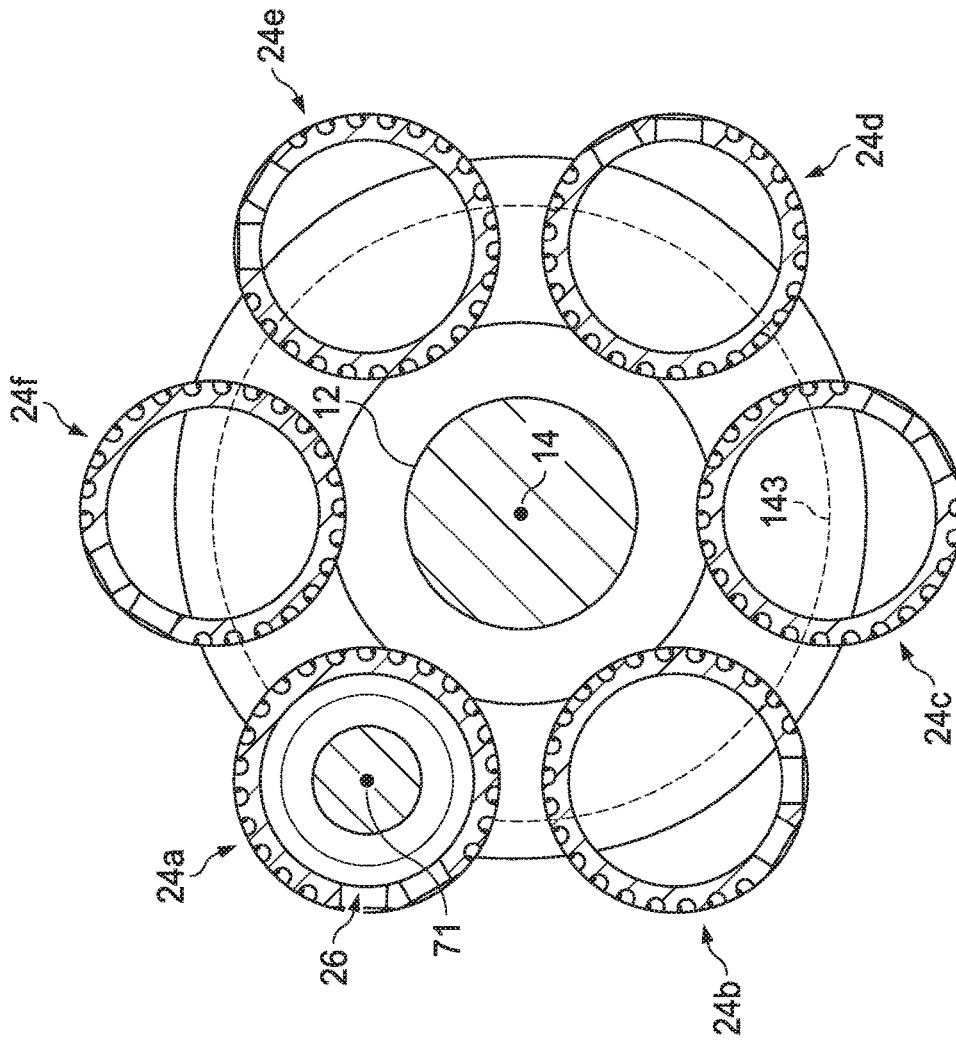

Fig. 7b

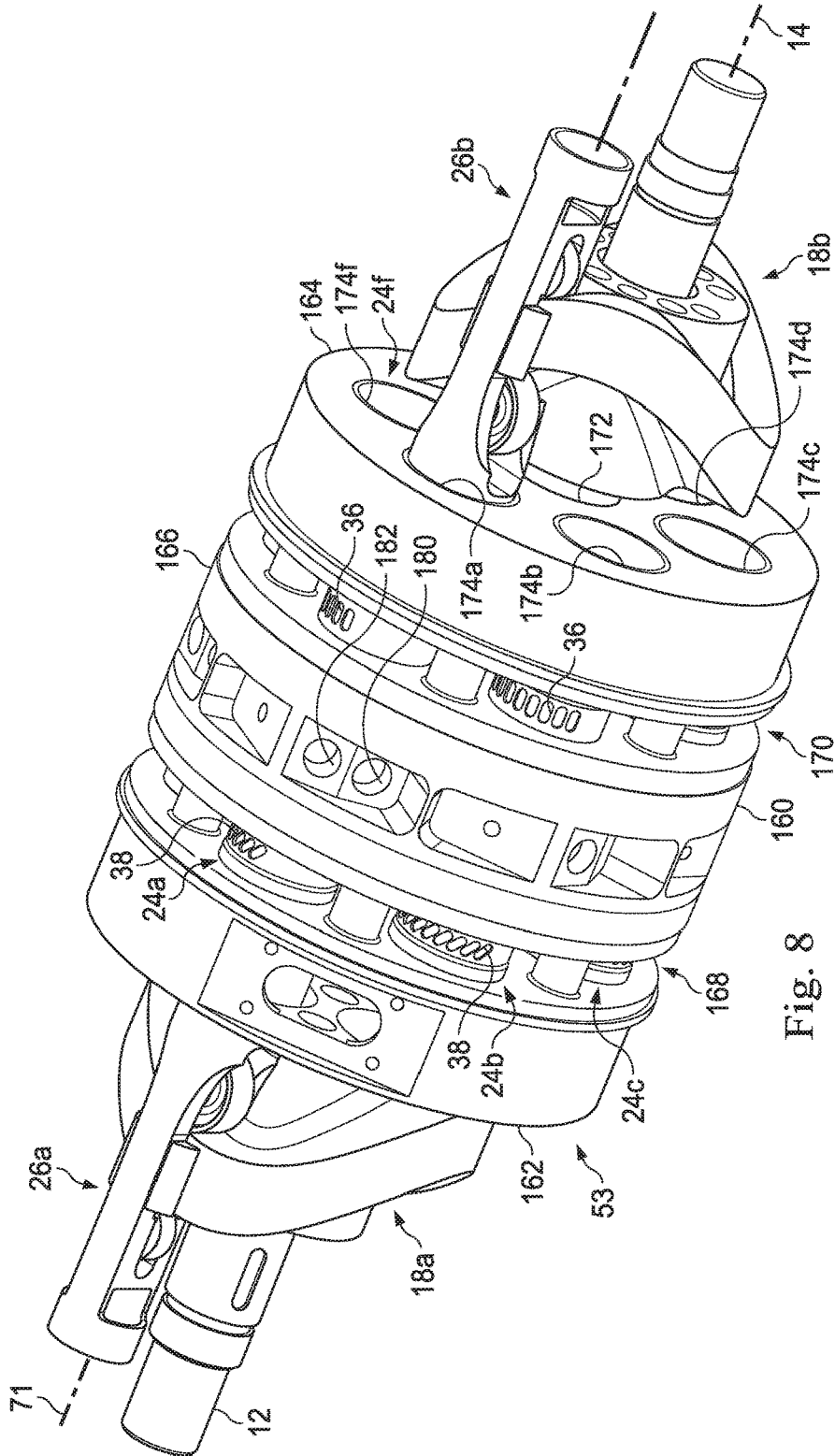

Fig. 8

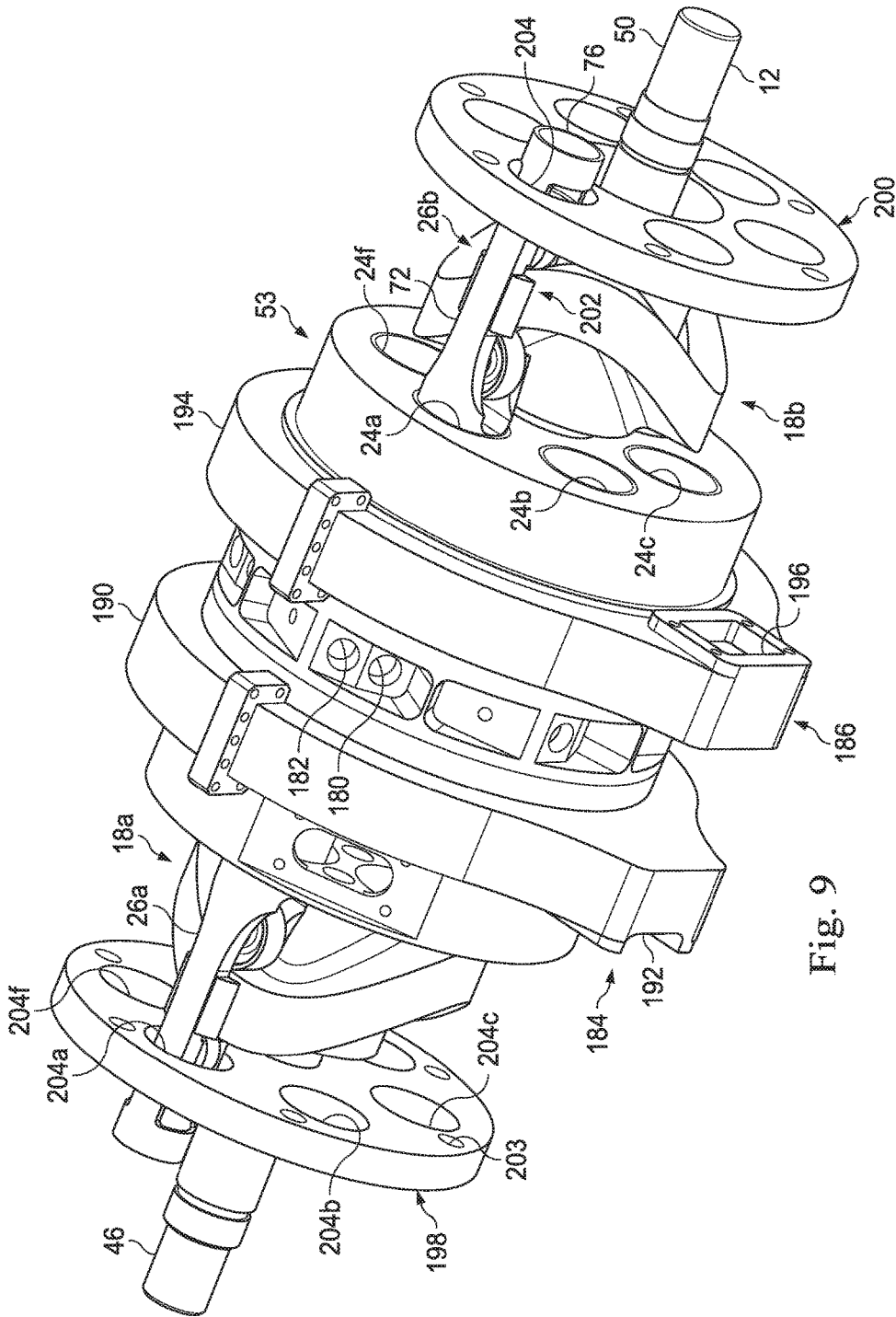

Fig. 9

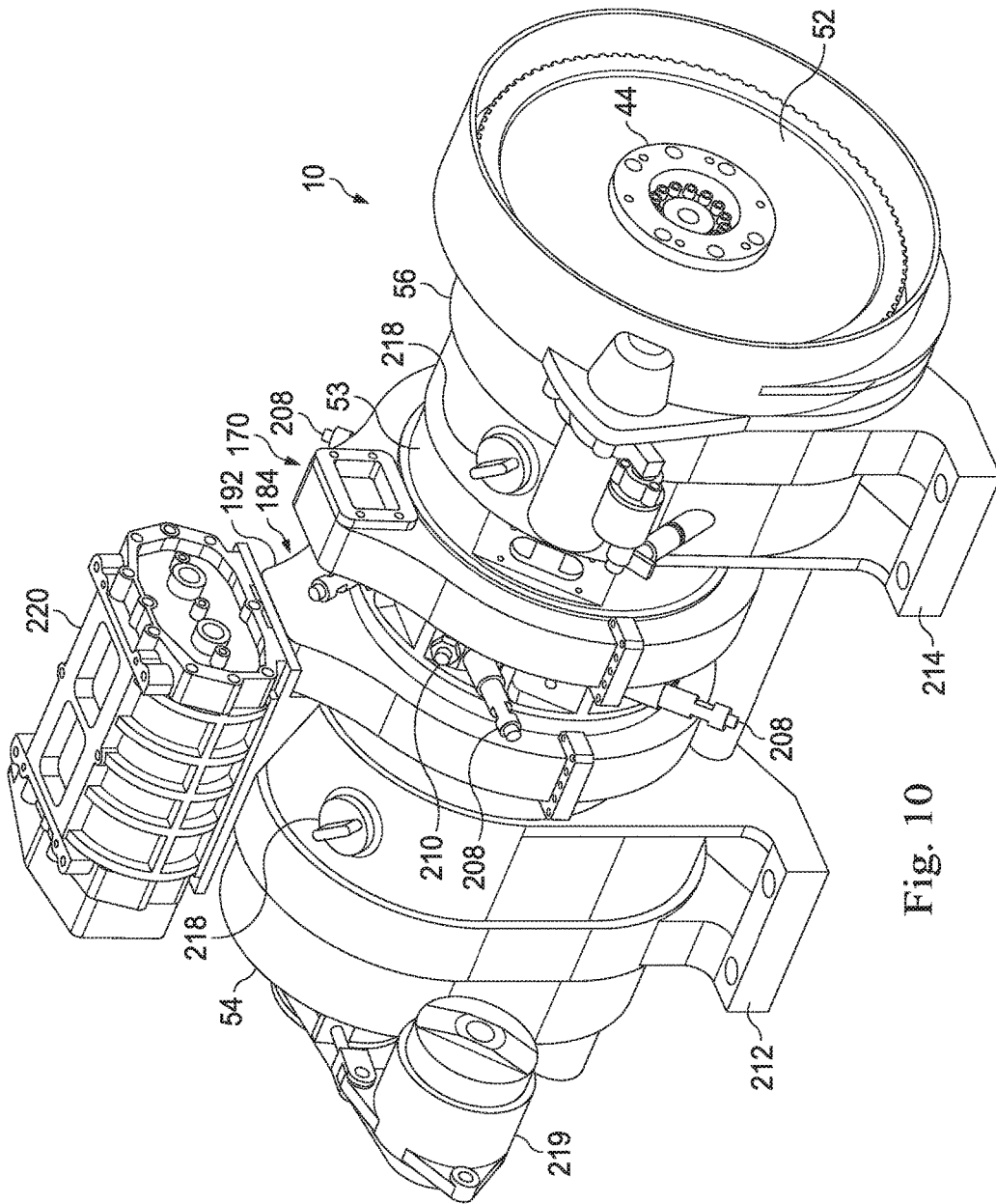

Fig. 10

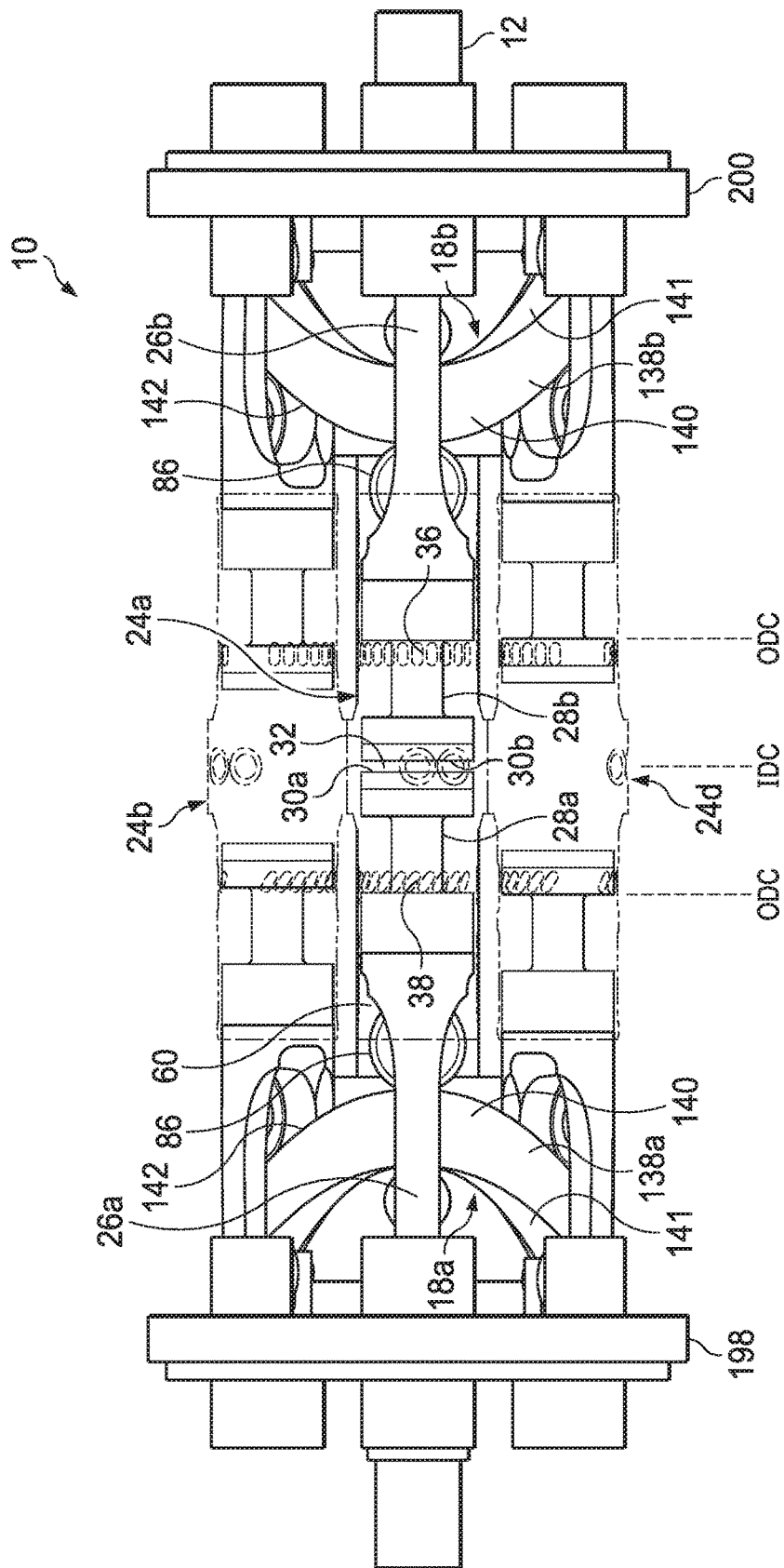

Fig. 11a

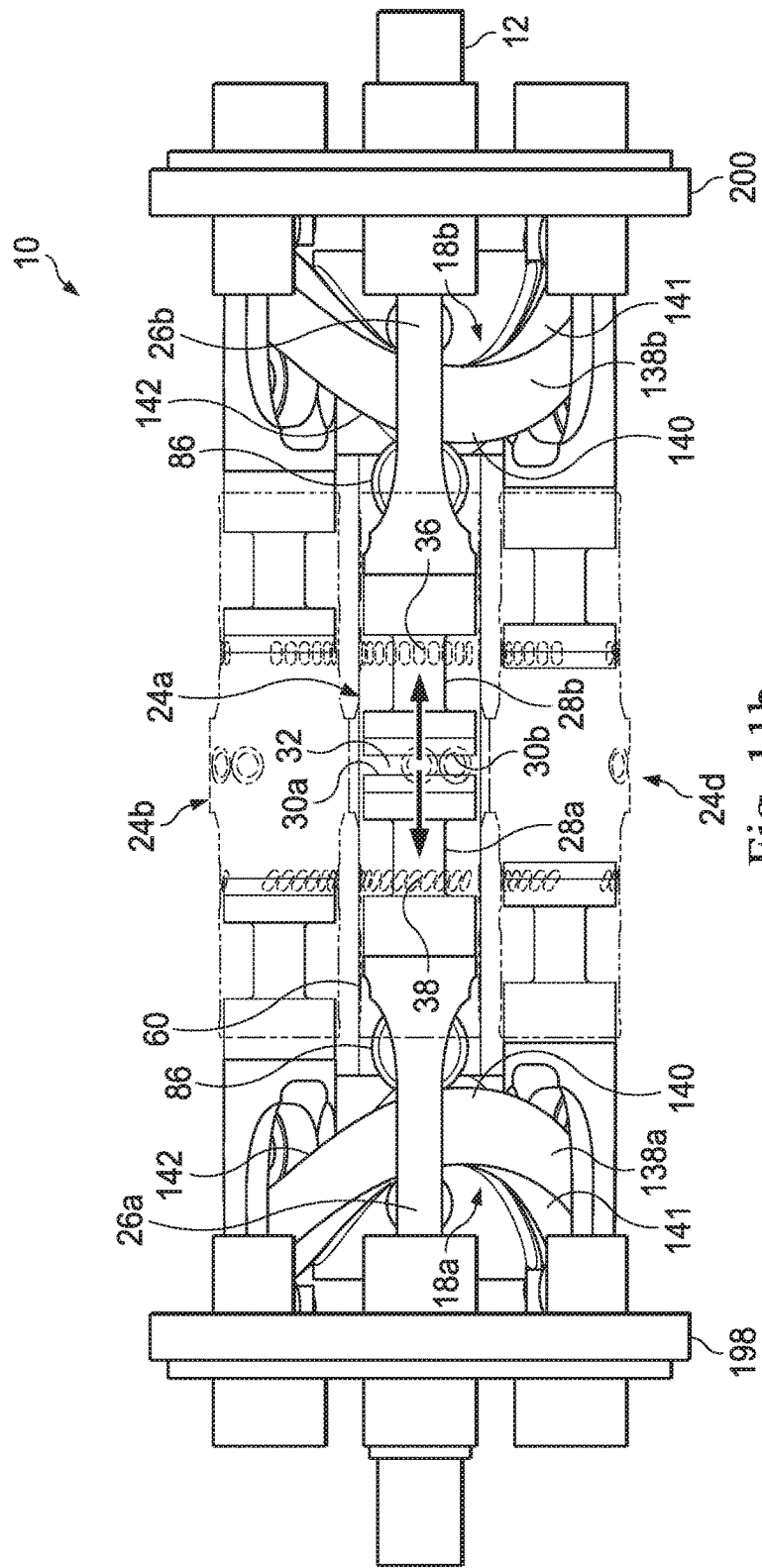

Fig. 11b

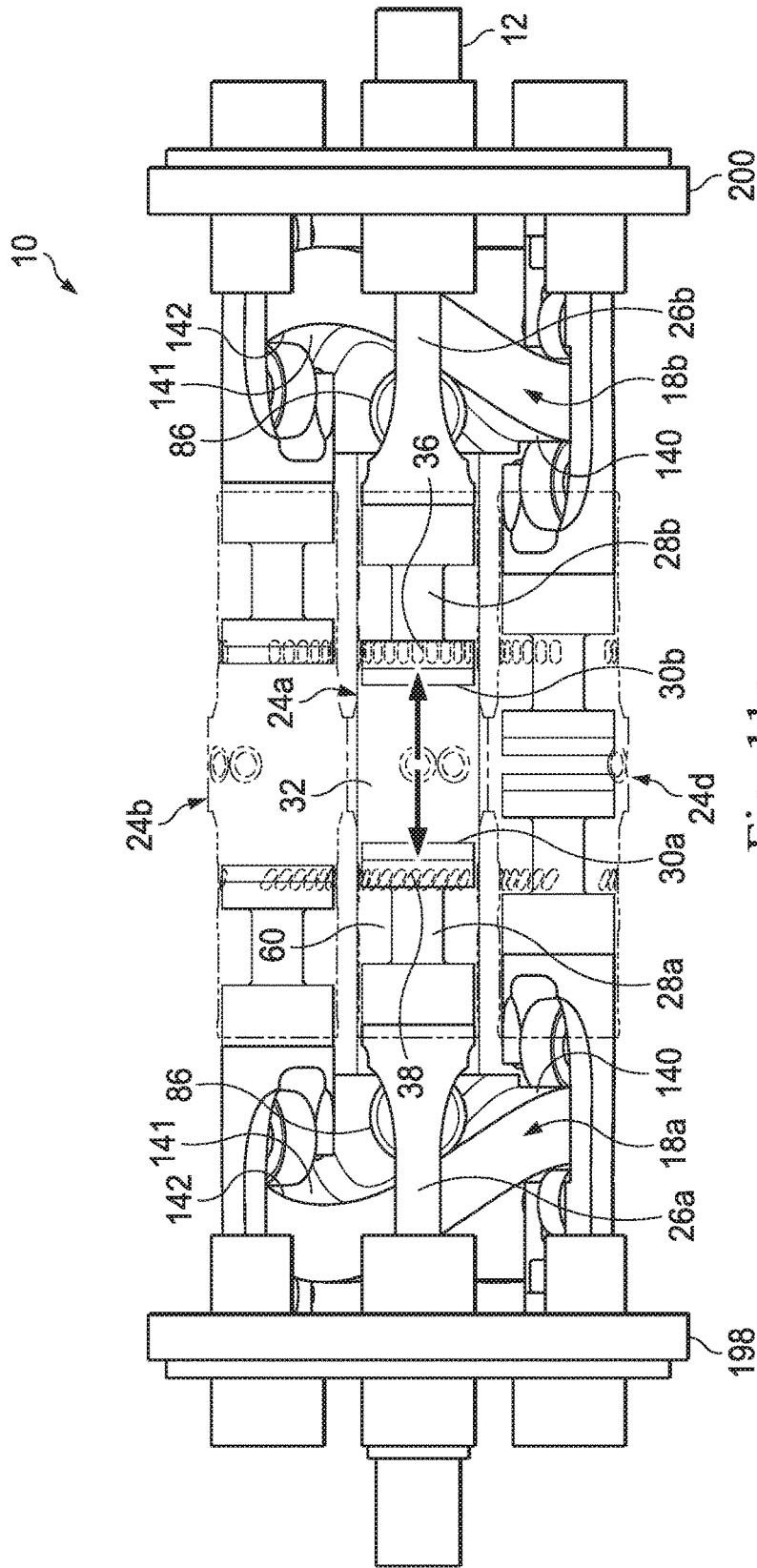

Fig. 11c

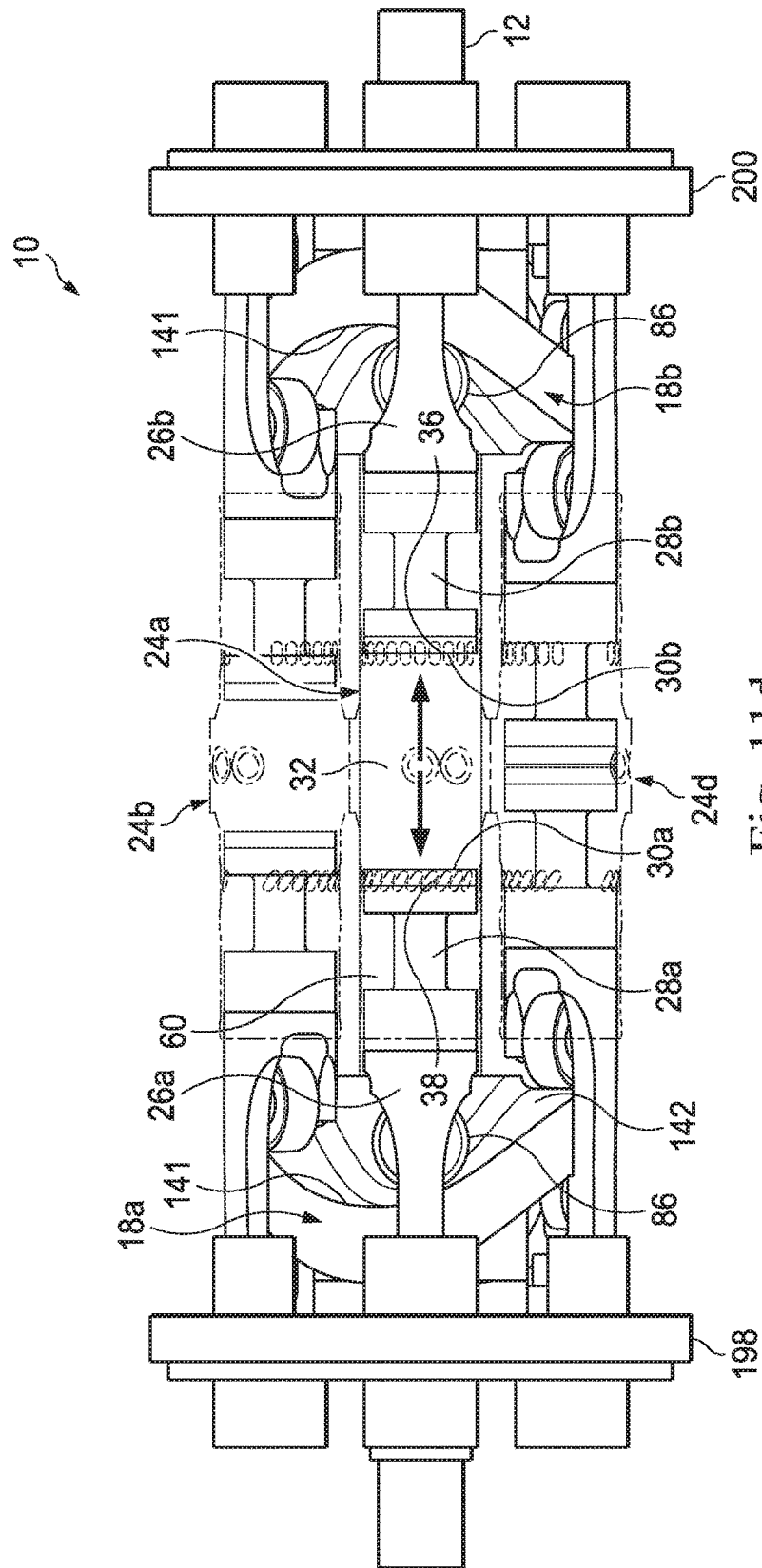

Fig. 11d

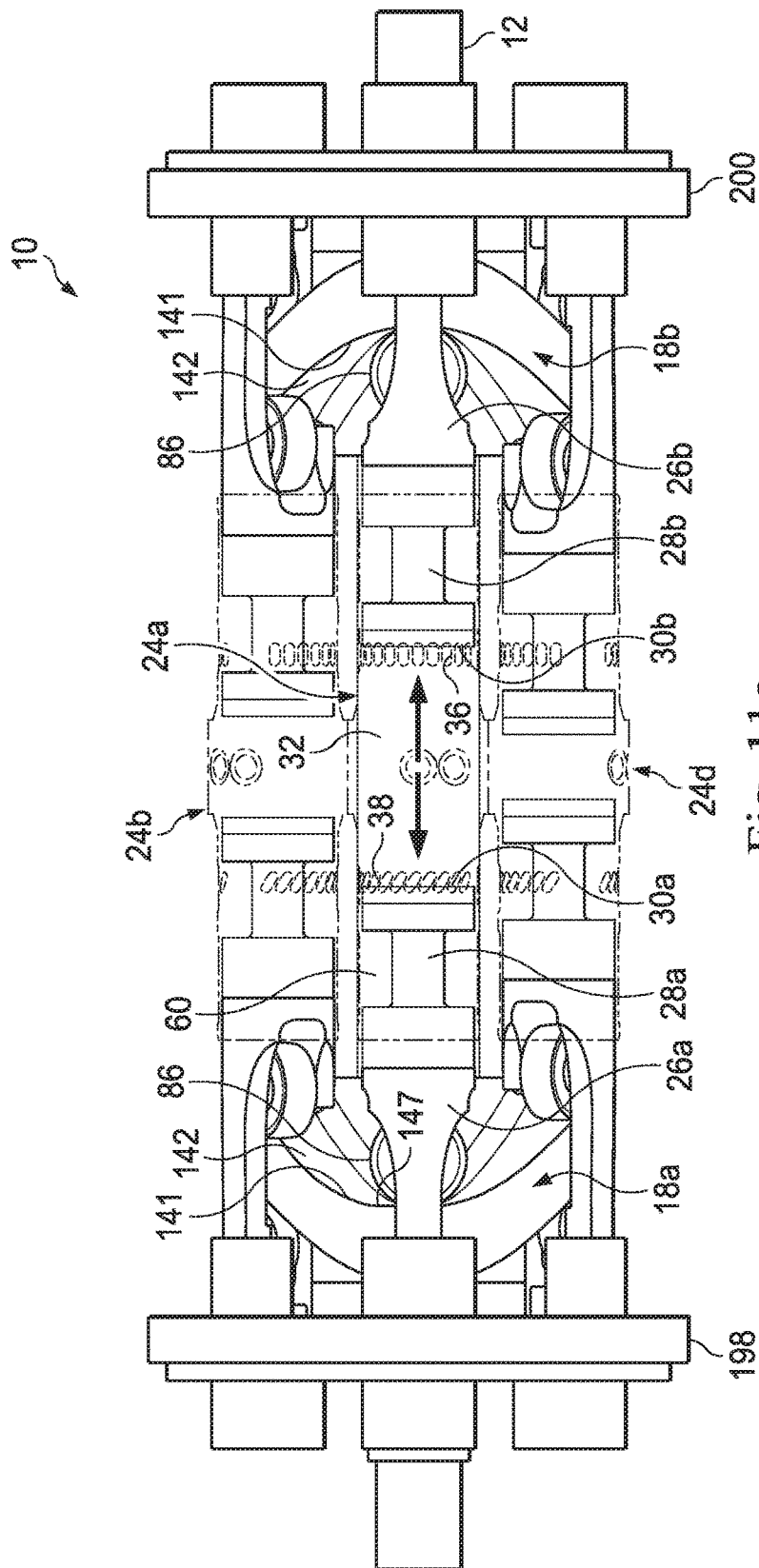

Fig. 11e

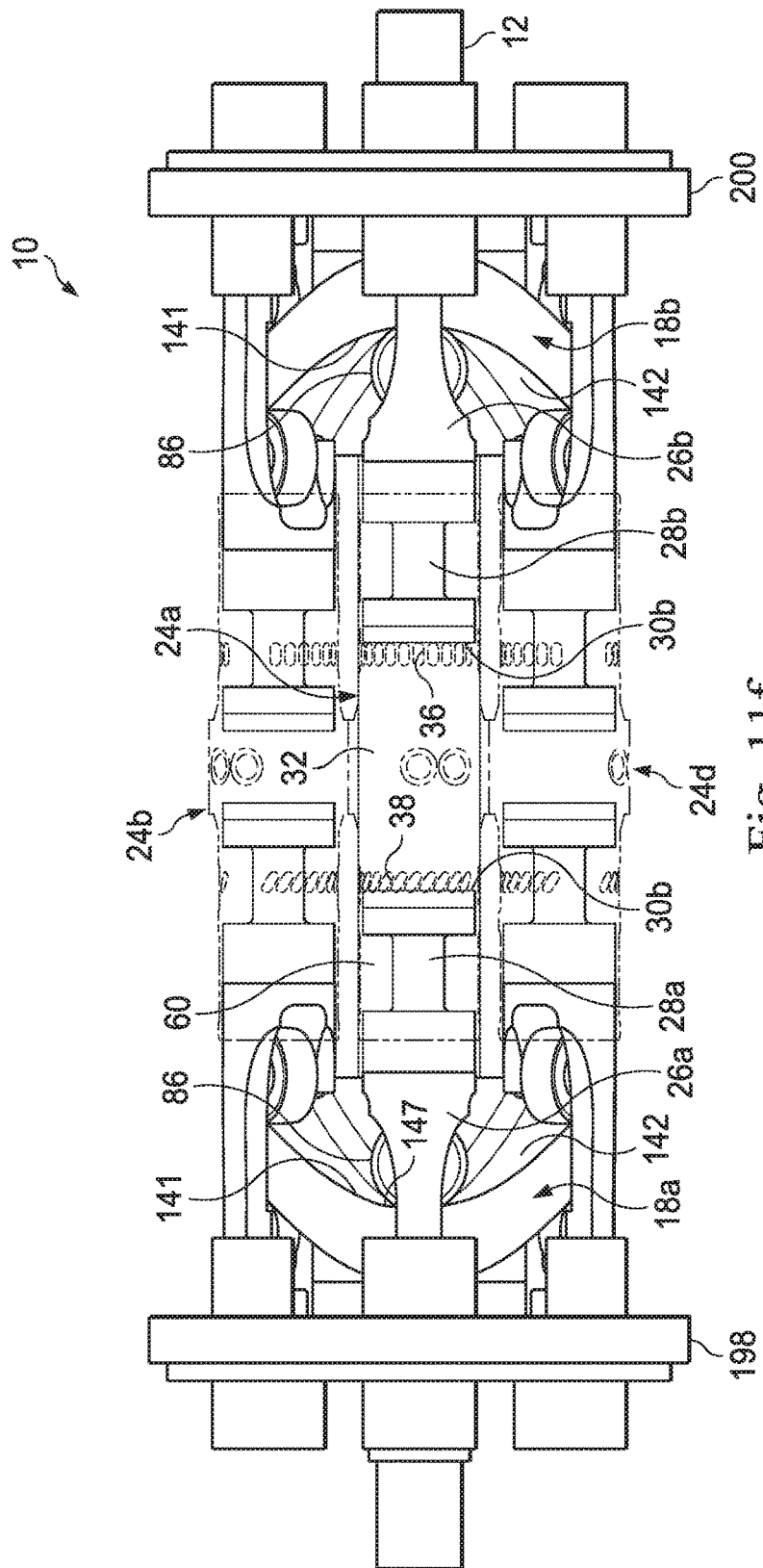

Fig. 11f

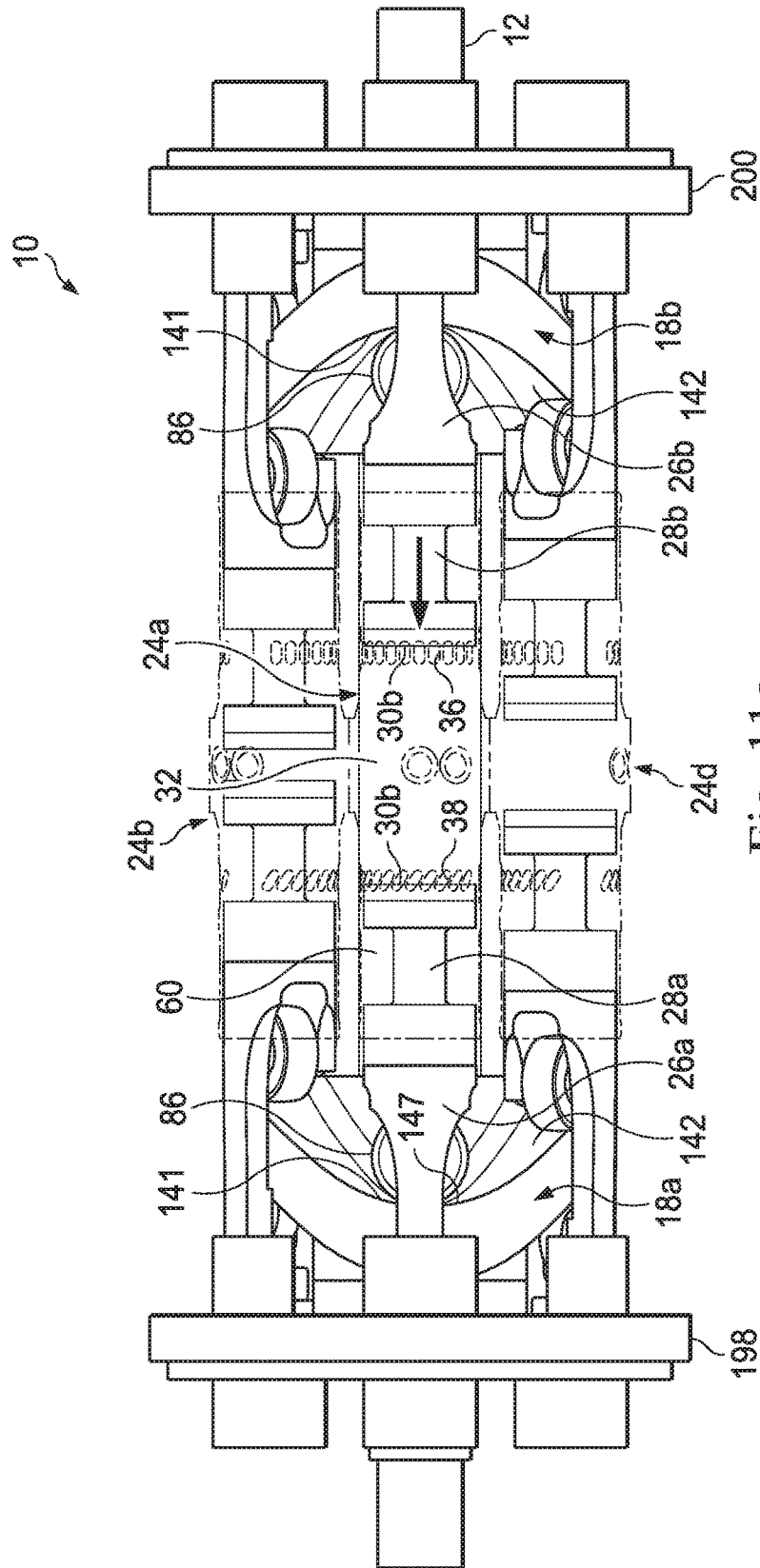

Fig. 11g

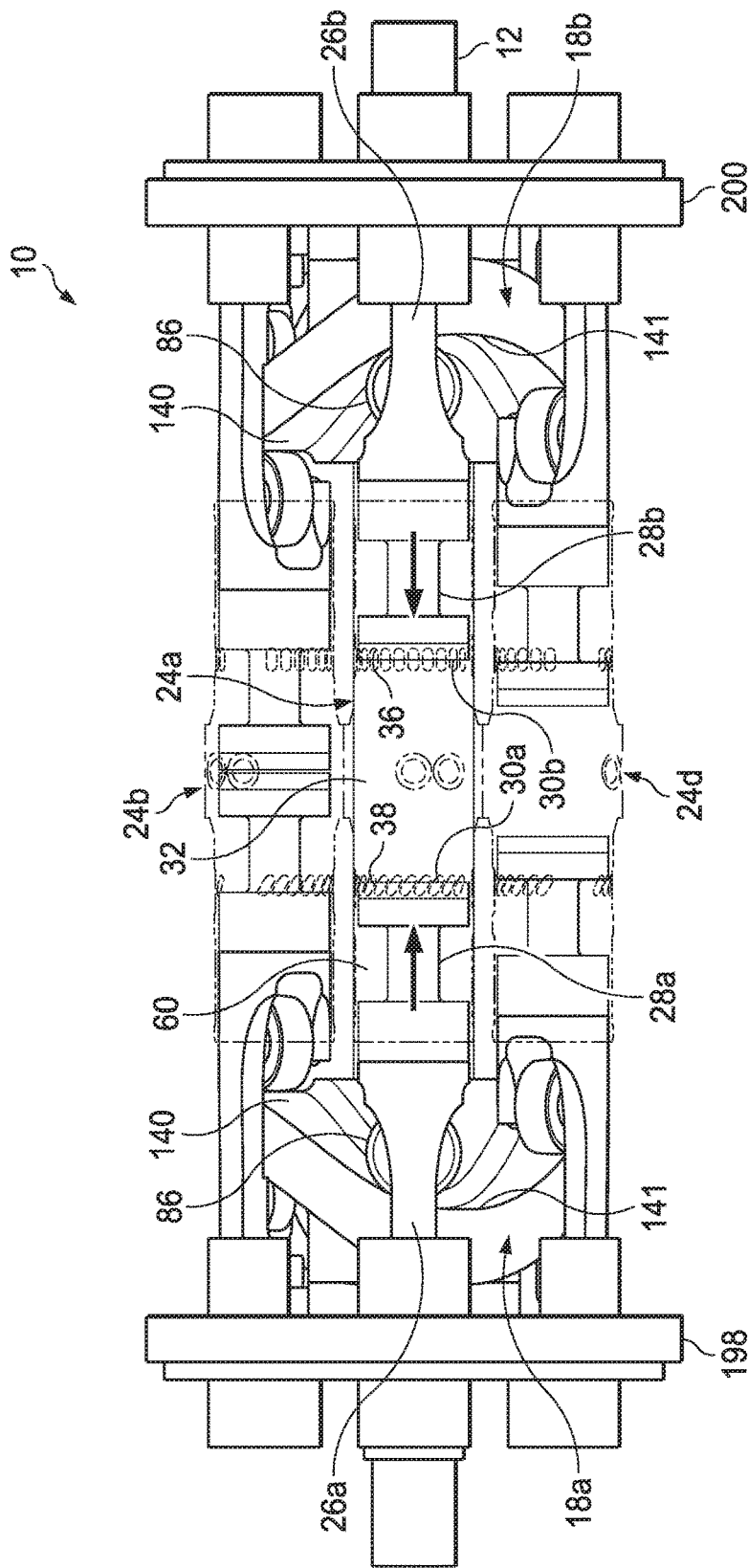

Fig. 11h

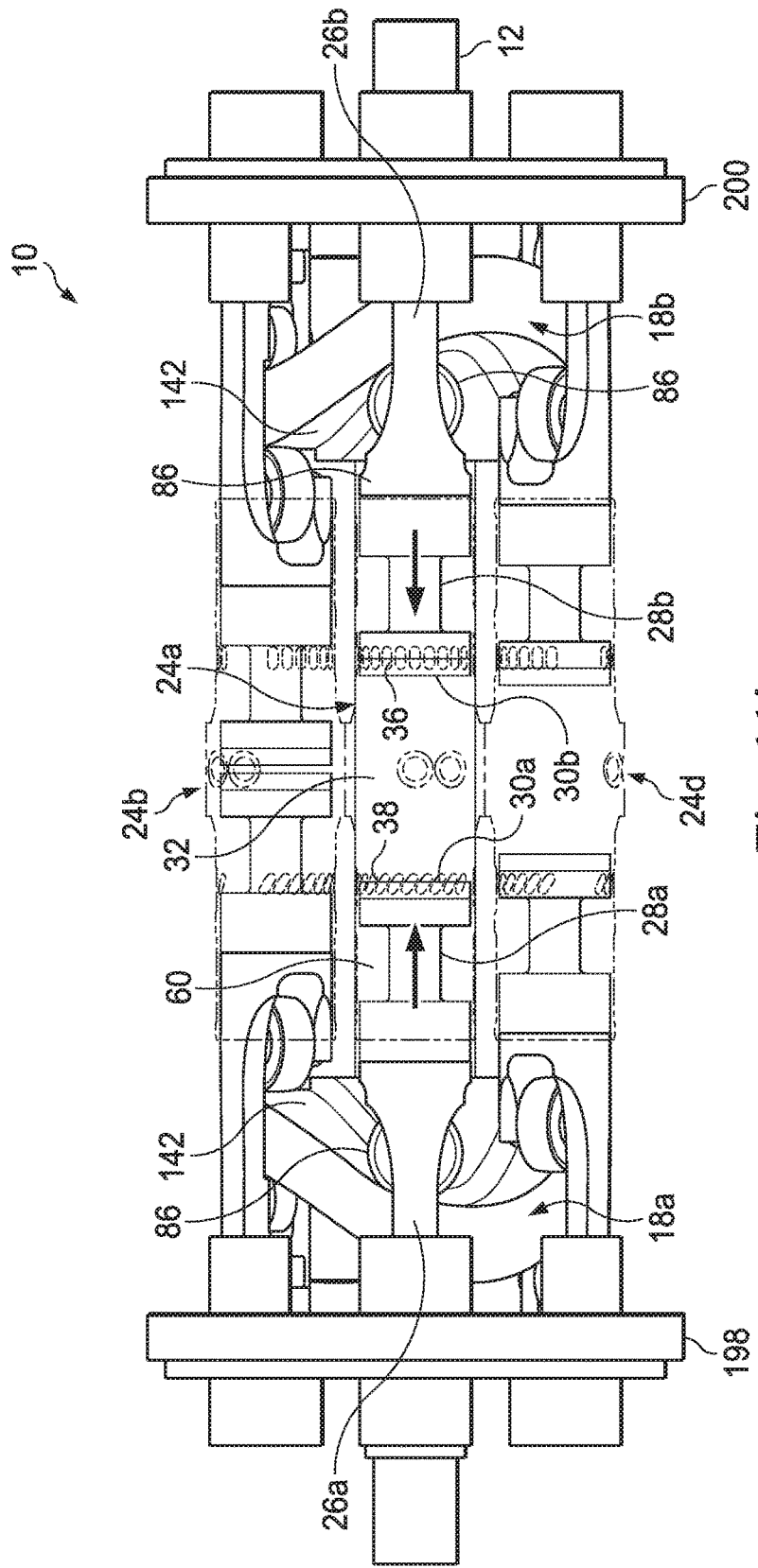

Fig. 11i

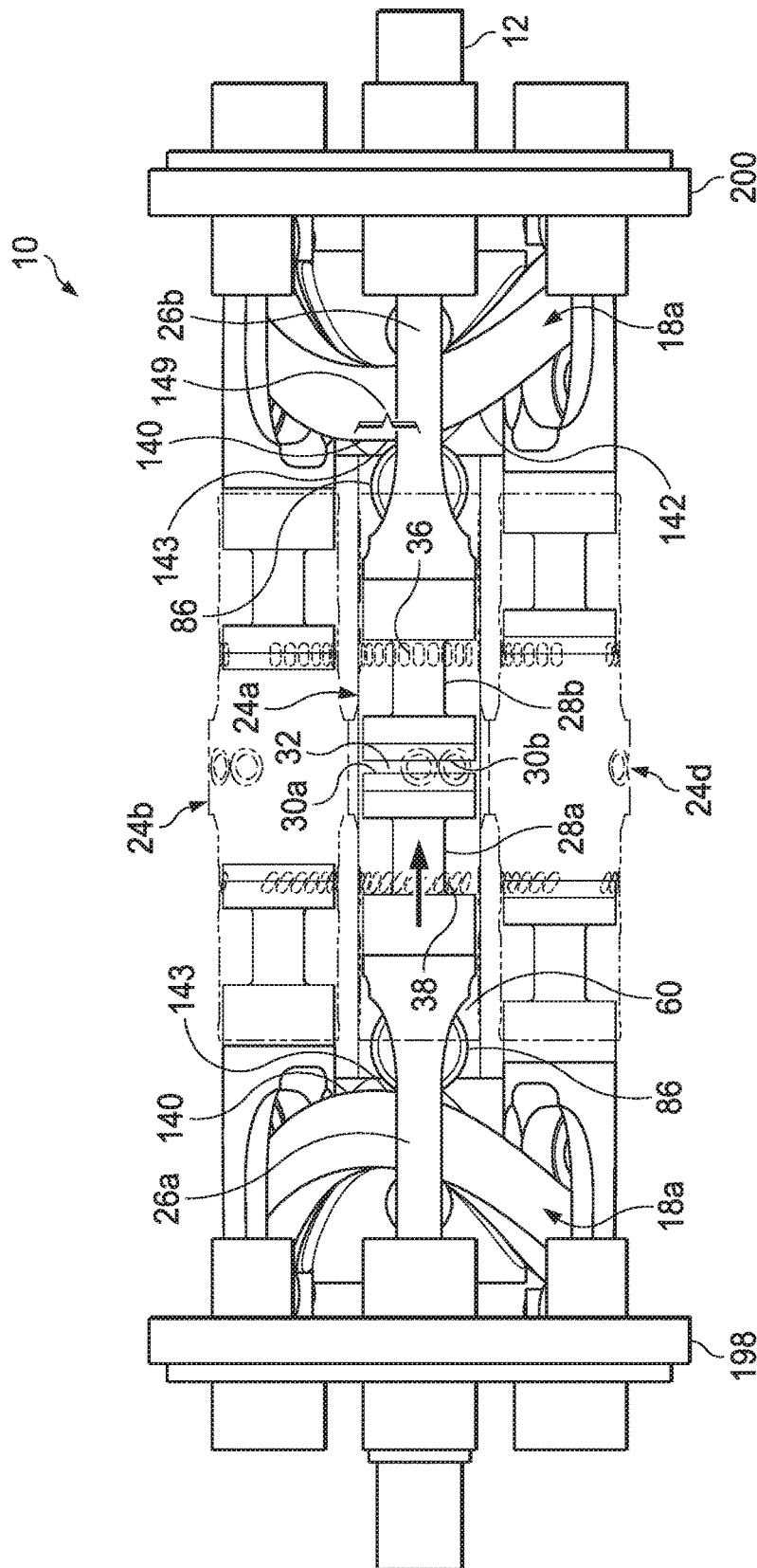

Fig. 11j

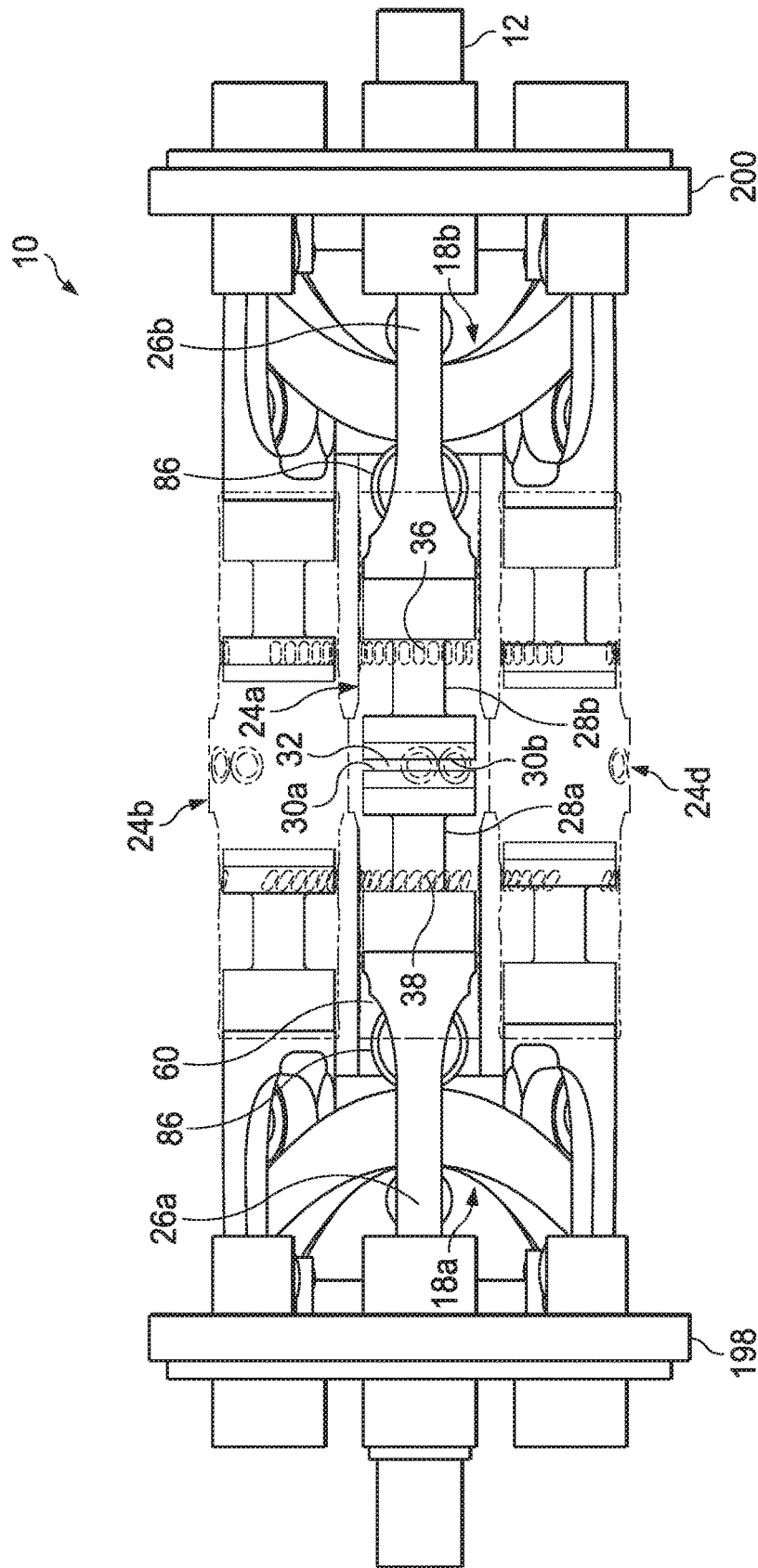

Fig. 11k

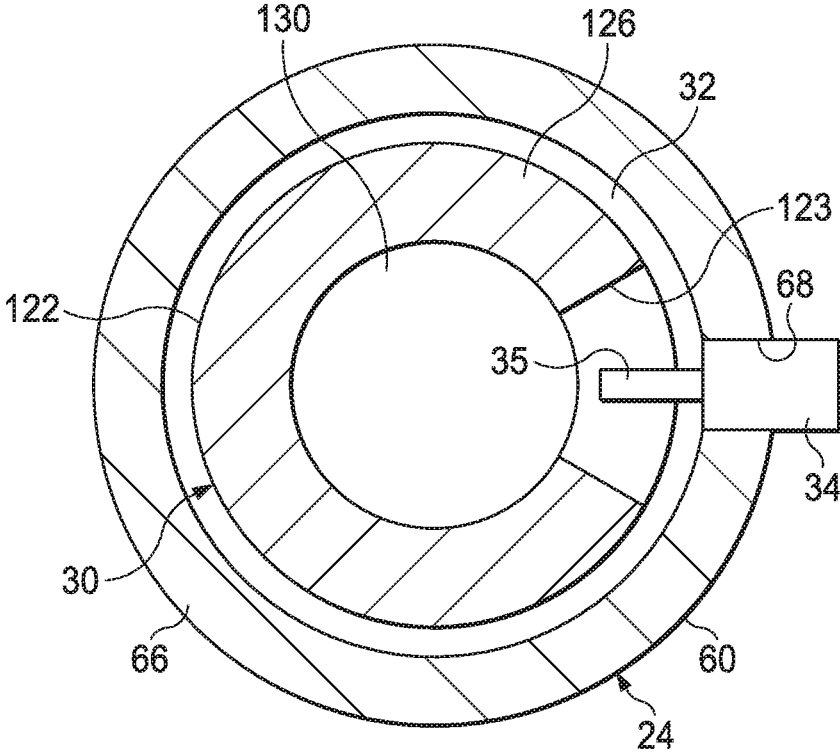

Fig. 12

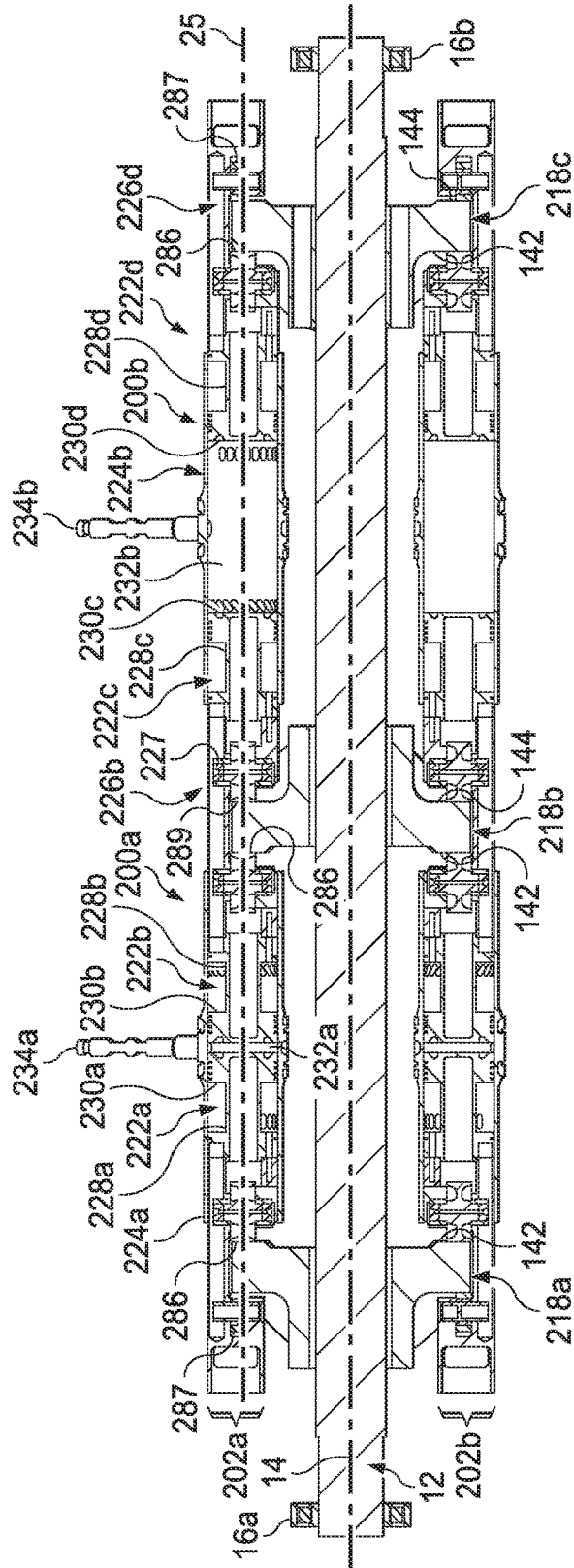

Fig. 13

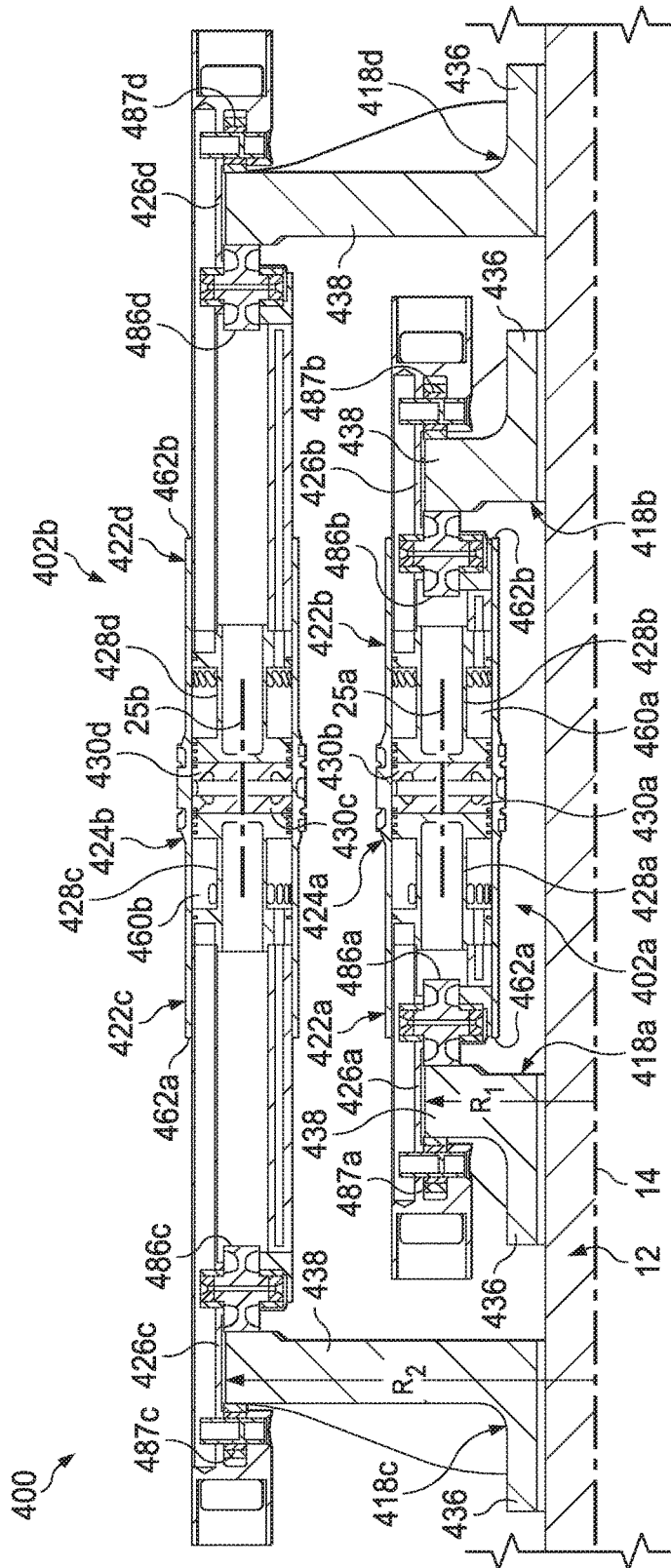

Fig. 14a

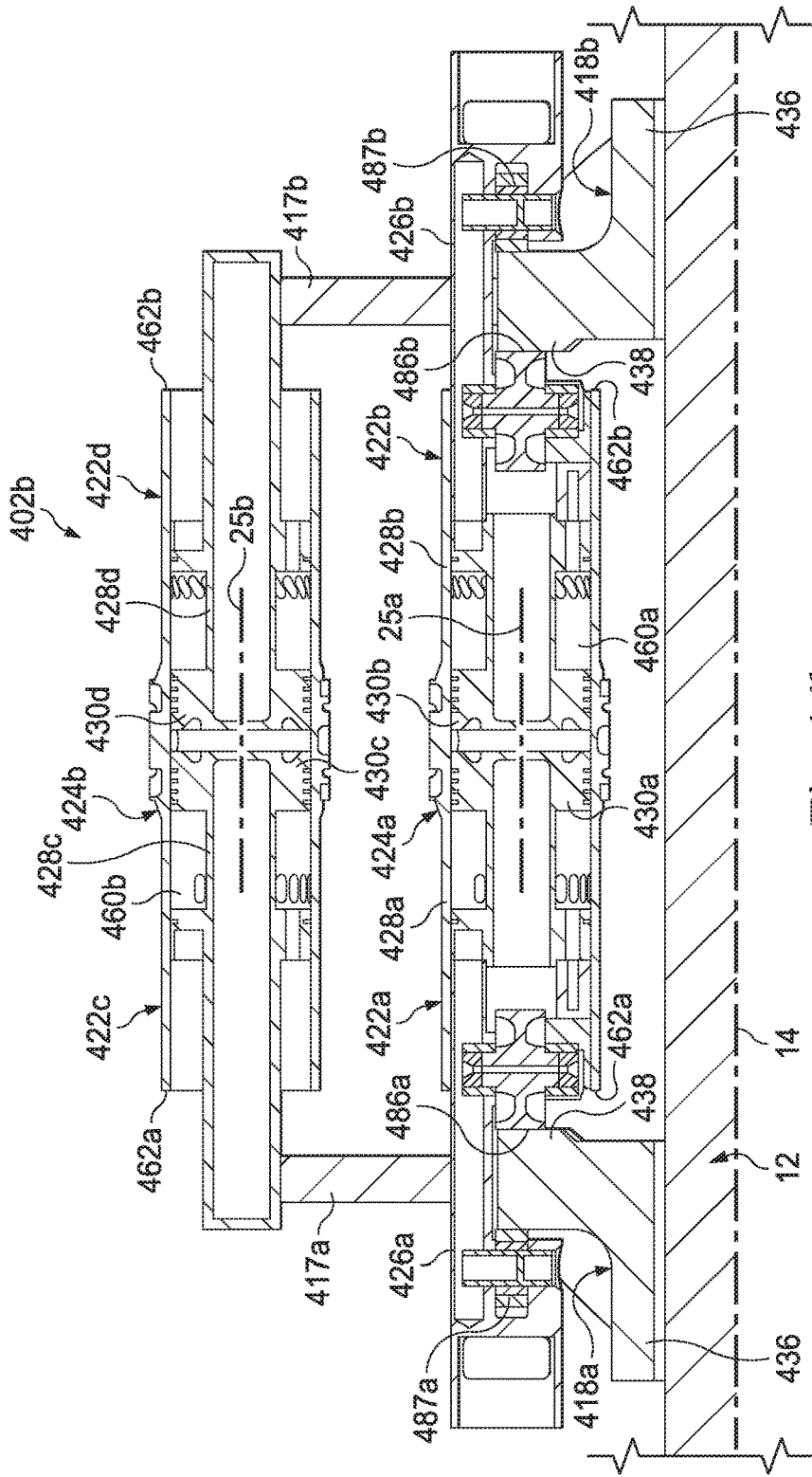

Fig. 14b

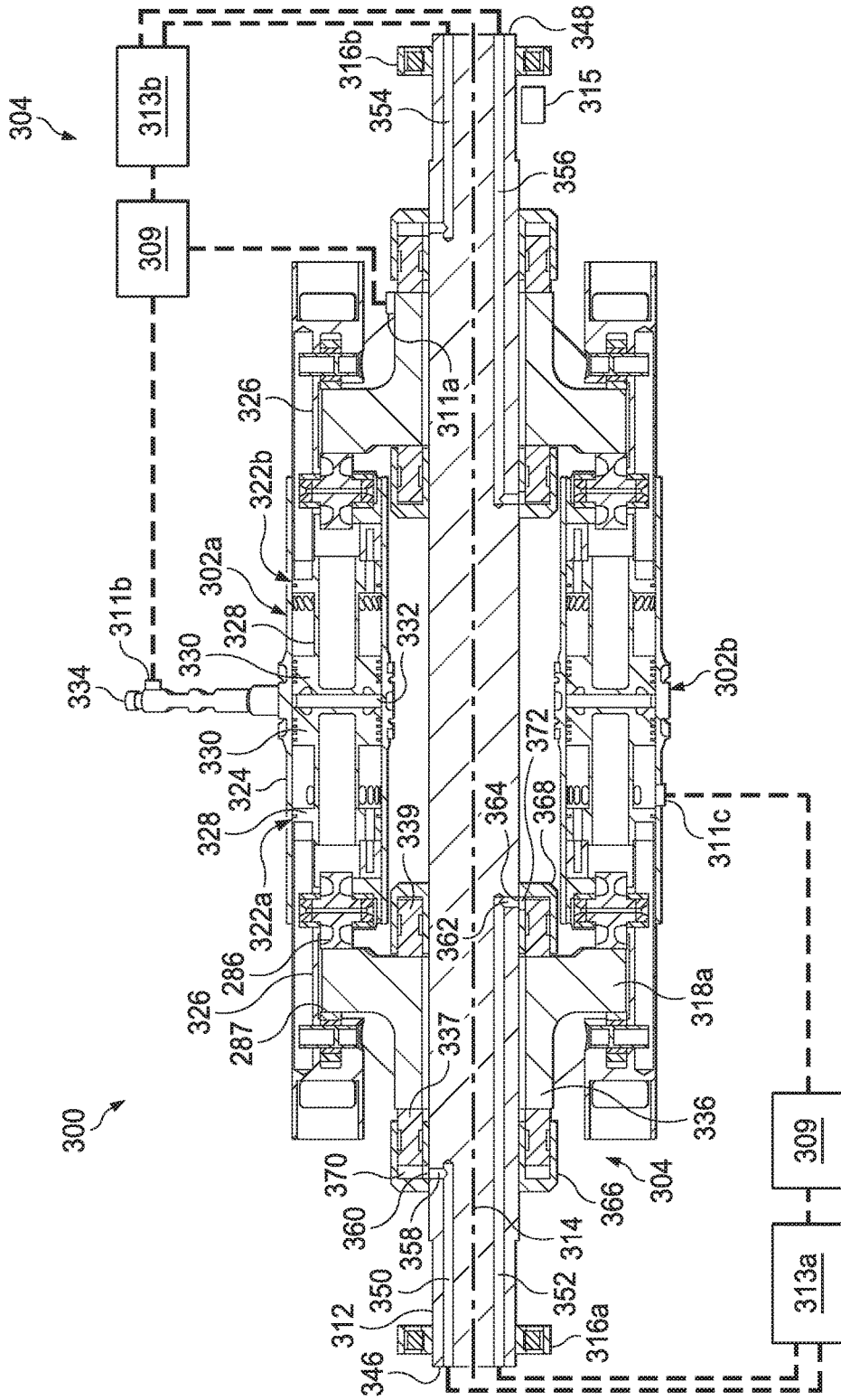

Fig. 15

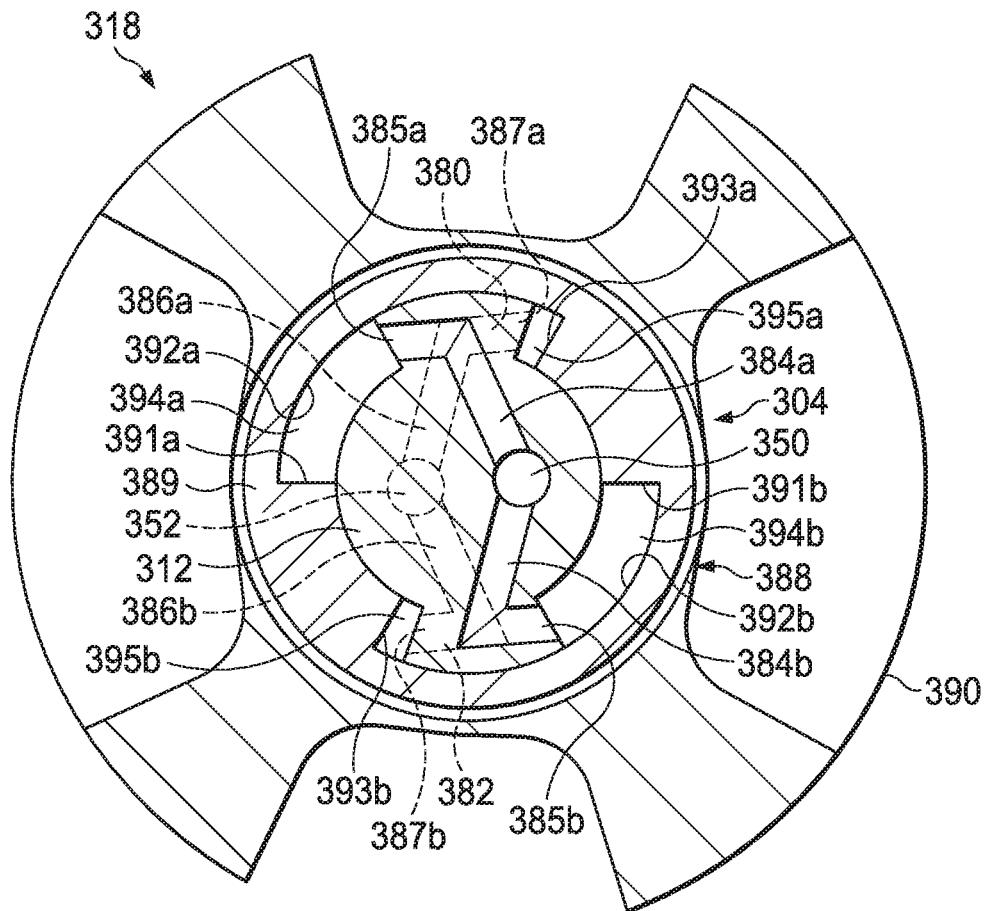

Fig. 16

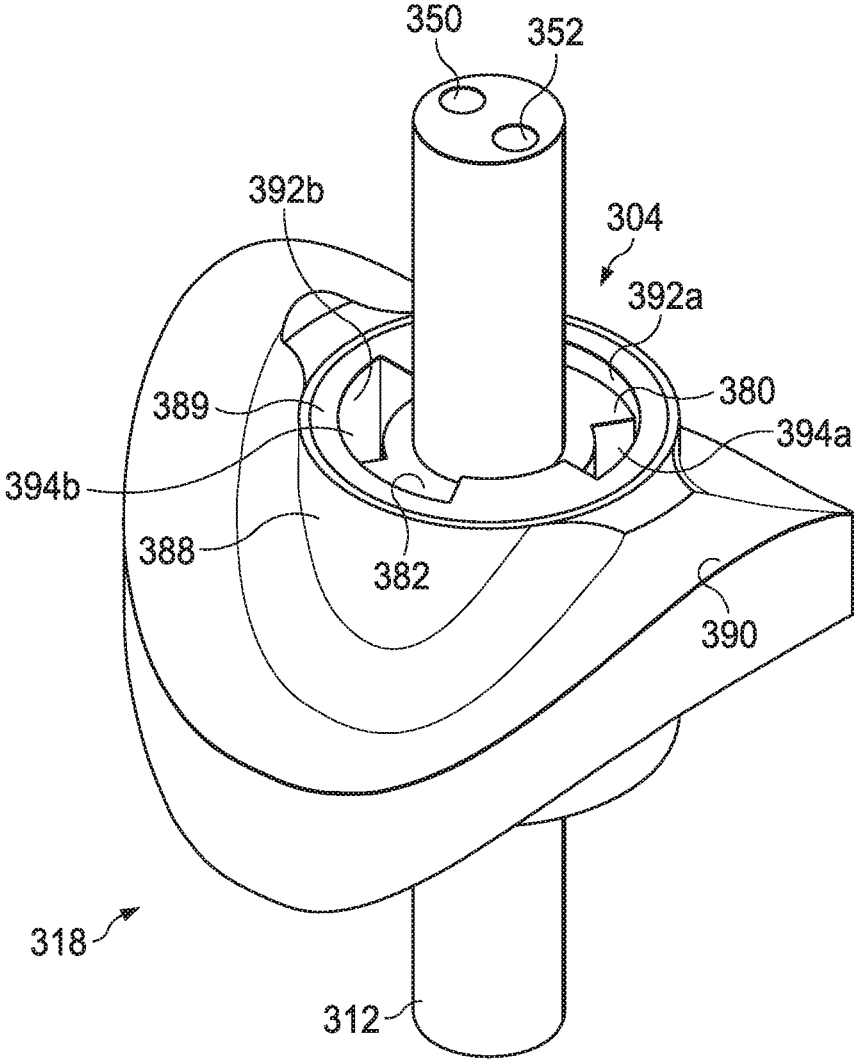

Fig. 17

## OPPOSED PISTON ENGINE CAM SHAPE

### PRIORITY

The present application claims priority to U.S. Provisional Application No. 62/756,846, filed on Nov. 7, 2018, and U.S. Provisional Application No. 62/807,084, filed Feb. 18, 2019, the benefit of which is claimed and the disclosures of which are incorporated herein by reference in their entirety.

### TECHNICAL FIELD OF THE INVENTION

The present disclosure relates to internal combustion barrel engines, and more particularly to opposed piston engines. More particularly still, the present disclosure relates to the shape and relative orientation of cam surfaces, piston design and piston rod assembly for opposed piston engines.

### BACKGROUND OF THE INVENTION

Axial piston engines, also called barrel type engines, are crankless, reciprocating internal combustion engines having one or more cylinders, each of which houses two opposed pistons arranged to reciprocate in opposite directions along the longitudinal axis of the cylinder. Crankless engines do not rely on the crankshaft for piston motion, but instead utilize the interaction of forces from the combustion chamber gases, and a rebound device (e.g., a piston in a closed cylinder). A main shaft is disposed parallel to, and spaced from, the longitudinal axis of each cylinder. The main shaft and pistons are interconnected via a swashplate such that reciprocation of the pistons imparts rotary motion to the main shaft. The swashplate has a generally sinusoidal cam surface or track that is engaged by each piston arm to impart axial motion to the piston. The shape of the track can be utilized to control the relative position of the piston head.

### BRIEF DESCRIPTION OF THE DRAWINGS

For a more complete understanding of the present disclosure and the advantages thereof, reference is now made to the following brief description, taken in connection with the accompanying drawings and detailed description:

FIG. 1 is a longitudinal section and cutaway view of an engine assembly constructed according to the present invention showing the axial-cylinder, opposed-piston layout utilizing twin, double-harmonic cams;

FIG. 2 is a perspective view of the engine assembly of FIG. 1;

FIG. 3 is an elevation view of a piston cylinder assembly;

FIG. 4a is an exploded elevation view of a piston assembly;

FIG. 4b is a perspective view of a piston crown;

FIG. 5a is an elevation view of a driveshaft with harmonic barrel cams mounted thereon;

FIG. 5b is a cam shoulder profile having a substantially sinusoidal shape;

FIG. 5c is a cam shoulder profile having a segmented polynomial shape;

FIG. 6 is an elevation view of a piston assembly engaging a harmonic barrel cam;

FIG. 7a is a perspective view of six-cylinder assemblies deployed about a driveshaft;

FIG. 7b is a cut away axial view of six-cylinder assemblies deployed about a driveshaft;

FIG. 8 is a perspective view of an engine block for a six-cylinder engine of FIG. 7a;

FIG. 9 is a perspective view of an engine illustrating annular air intake and exhaust manifolds;

FIG. 10 is a perspective view of an assembled engine of the disclosure;

FIGS. 11a-11k illustrate the movement of pistons of a piston pair through an engine stroke.

FIG. 12 is a cross-sectional view of a cylinder assembly with a fuel injection nozzle extending into a combustion chamber;

FIG. 13 is a cut-away side view of a barrel engine with piston pairs axially aligned in series;

FIG. 14a is a cut-away side view of one embodiment of a barrel engine with piston pairs deployed in parallel;

FIG. 14b is a cut-away side view of another embodiment of a barrel engine with piston pairs deployed in parallel;

FIG. 15 is a cut-away side view of a barrel engine with a radial adjustment mechanism for altering the relative position of a cam on a driveshaft;

FIG. 16 is a cut-away axial view another embodiment of a radial adjustment mechanism for altering the relative position of a cam on a driveshaft;

FIG. 17 is a perspective view of the radial adjustment mechanism of FIG. 16.

### DETAILED DESCRIPTION OF THE EMBODIMENTS

FIG. 1 shows a simplified longitudinal section and cut-away view of a 2-stroke engine assembly 10 of the present invention, while FIG. 2 shows a perspective view of engine assembly 10. Driveshaft 12 extends along a driveshaft axis 14 and passes axially through the center of the assembly 10. Driveshaft 12 is supported by a pair of bearings 16a, 16b in a fixed axial position. Positioned along driveshaft 12 in spaced apart relationship to one another are harmonic barrel cams 18a, 18b. Positioned radially outward from driveshaft 12 are two or more piston pairs 20, each piston pair 20 having a first piston assembly 22a and a second piston assembly 22b which piston assemblies 22a, 22b are axially aligned with one another within a combustion cylinder assembly 24 disposed along a cylinder axis 25. In the illustrated embodiment, two piston pairs 20a, 20b are illustrated, with each piston pair 20 having first and second piston assemblies 22a, 22b. Cylinder axis 25 is spaced apart from but generally parallel with driveshaft axis 14 of driveshaft 12. Each piston assembly 22 generally includes a cam follower assembly 26 attached to a piston arm 28 to which is mounted a piston 30. The opposed pistons 30a, 30b of a piston pair 20 are adapted to reciprocate in opposite directions along cylinder axis 25. Each cam follower assembly 26 straddles a corresponding cam 18 and acts on a piston 30 through its associated piston arm 28. Opposed pistons 30a, 30b within cylinder assembly 24 generally define a combustion chamber 32 therebetween into which fuel may be injected by a fuel injector 34. Upon combustion of fuel within combustion chamber 32, opposed pistons 30a, 30b are driven away from one another along cylinder axis 25.

Engine assembly 10 includes at least two piston pairs 20 symmetrically spaced about driveshaft axis 14. In the illustrated embodiment, a first piston pair 20a and a second piston pair 20b are shown, each engaging a combustion cylinder assembly 24. In other embodiments, three or more piston pairs 20 each with a corresponding combustion cylinder assembly 24 may be symmetrically spaced about driveshaft axis 14.

As will be explained in more detail below, as opposing pistons 28 are displaced in equal and opposite directions as

a result of combustion. Their respective cam follower assemblies 26 are likewise linearly displaced, which forces cams 18 engaged by the cam follower assemblies 26 to rotated axially about driveshaft axis 14. Since cams 18 are fixedly mounted on driveshaft 12, driveshaft 12 is rotated through an angle by cam 18. The shape of cam 18, being engaged by cam follower assembly 26, therefore determines the stroke of each piston assembly 22.

Air is supplied to combustion chamber 32 via air intake ports 36 formed in combustion cylinder assembly 24, while exhaust is removed from combustion chamber 32 via exhaust ports 38 formed in combustion cylinder assembly 24. An air intake manifold 40 is in fluid communication with intake ports 36, while an exhaust manifold 42 is in fluid communication with exhaust ports 38. In one or more embodiments, one or both of manifolds 40, 42 may be annular, extending at least partially around the perimeter of engine assembly 10. In some embodiments, manifolds 40, 42 are toroidal in shape, extending fully around the perimeter of engine assembly 10.

In one or more embodiments, a first flange 44 is attached to a first end 46 of driveshaft 12 and a second flange 48 is attached to a second end 50 of driveshaft 12. As shown, a flywheel 52 is mounted on first flange 44.

The piston assemblies 22 and combustion cylinder assembly 24 are mounted in an engine block 53. A sump casing 54 is attached to the engine block 53 adjacent the first end 46 of driveshaft 12 and a sump casing 56 is attached to engine block 53 adjacent the second end 50 of driveshaft 12.

FIG. 3 illustrates the combustion cylinder assembly 24 disposed along a cylinder axis 25 in more detail. Specifically, combustion cylinder assembly 24 is formed of a combustion cylinder 60 extending between a first end 62 and a second end 64 and generally formed of a cylinder wall 66. A first combustion port 68 may be provided in cylinder wall 66, in some embodiments, at approximately the midpoint between first and second ends 62, 64. First combustion port 68 may be a fuel injection port, a sparkplug port or other port. In one or more embodiments, a second combustion port 70 may likewise be provided adjacent first combustion port 68. Second port 70 may be an additional fuel injection port or alternatively, a sparkplug port, it being appreciated that in some embodiments, compression of a combustible fuel is sufficient to ignite the fuel, while in other embodiments, a spark may be necessary to ignite the fuel. In yet other embodiments, additional combustion ports may be provided adjacent port 68, where each fuel injection port may be utilized for a different type of fuel, it being an advantage of the engine assembly 10 that it may utilize a variety of fuel types without the need to adapt the general components of the engine for a particular fuel type. Fuels on which engine assembly 10 may run include for example liquid fuels such as diesel, ethanol, gasoline, kerosene and gaseous fuels such as SymGas, hydrogen and natural gas.

An exhaust port 36 is formed in wall 66 between fuel injection port 68 and the second end 64 of cylinder 60, and an intake port 38 is formed in wall 66 between injection port 68 and the first end 62 of cylinder 60. In one or more embodiments, intake port 38 has an outer port edge 61 closest to the first end 62 and an inner port edge 63 closest to second end 64. Similarly, exhaust port 36 has an outer port edge 65 closest to the second end 64 and an inner port edge 67 closest to first end 62. Inner dead center (IDC) of the combustion cylinder 60 is defined approximately equidistance between the outer edge 61 of the intake port 38 and the outer edge 65 of the exhaust port 36. In one or more embodiments, the inner port edge 67 of the exhaust port 36

is closer to inner dead center than the inner port edge 63 of the intake port 38, while the outer port edge 65 of exhaust port 36 is approximately the same distance from IDC as the outer port edge 61 of intake port 38, it being appreciated that as such, exhaust port 36 is longer along axis 26 than intake port 38. Moreover, outer dead center (ODC) of the combustion cylinder 60 is defined approximately equidistance from ODC at the outer edges 61, 65 of the respective intake port 38 and exhaust port 36. In one or more embodiments, ports 38 are a plurality of slots. In one or more embodiments, ports 36 are a plurality of slots. In one or more embodiments, ports 36 are a plurality of slots each formed along a longitudinal axis that is generally parallel with cylinder axis 25. In one or more embodiments, ports 38 are a plurality of slots each formed along a longitudinal axis that is generally acute with cylinder axis 25. Ports 38 may be a plurality of slots formed at an angle relative to the cylinder axis 25 so as to promote swirl in the incoming air passing into cylinder 60, thereby enhancing mixture with fuel and combustion. In one or more embodiments, the plurality of slots are formed in cylinder wall 66 so as to have an angle of between 30-45 degrees with cylinder axis 25.

In one or more embodiments, one or both sets of ports 36, 38 extend only around a portion of the perimeter of wall 66. For example, ports 36 and/or 38 may extend only around 180 degrees of the perimeter of wall 66 or ports 36 and/or 38 may extend only around 90 degrees of the perimeter of wall 66. With respect to intake ports 38, intake ports 38 are provided only around that portion of the cylinder wall 66 that is not adjacent piston head notch (see FIG. 4) as described below. With respect to the exhaust ports 36, exhaust ports 36 are provided only around that portion of the cylinder wall 66 that is not adjacent piston head notch (see FIG. 4) as described below. In addition, to minimize exhaust heat transfer to the engine block 53 and other components of engine assembly 10, exhaust ports 36 are provided only around that portion of the cylinder wall 66. It will be appreciated that this arrangement alone, but particularly in combination with the exhaust arrangement described with respect to FIGS. 8 and 9, minimizes transfer of exhaust heat to other components of the engine. As such, during operation, the overall engine remains much cooler than prior art engines. Moreover, by controlling heat transfer in this manner, certain engine components may be manufactured of materials that need not be selected to withstand the high temperatures associated with prior art engines. For example, certain engine components may be manufactured of plastics, ceramics, glass, composites or lighter metals, thus reducing the overall weight of the engine of the disclosure.

Turning to FIG. 4A, an exploded side view of a piston assembly 22 is illustrated. Piston assembly 22 generally includes a cam follower assembly 26 attached to a piston arm 28 to which is mounted a piston 30, all generally aligned along axis 71. As used herein, a "hot" piston assembly 22 will be the piston assembly 22 adjacent exhaust ports 36 while "cool" piston assembly 22 will be the piston assembly 22 adjacent the intake ports 38 of a cylinder assembly 24.

Cam follower assembly 26 includes an elongated body 72 having a first end 74 and a second end 76. Body 72 may generally be cylindrical in shape at each of the ends 74, 76 which ends 74, 76 may be interconnected by an arm 78. In some embodiments, cylindrical end 74 may be of a larger diameter than cylindrical end 76. An axially extending slot 80 is formed in body 72 adjacent first end 74. An additional axially extending slot 82 is formed in body 72 in spaced apart relationship to slot 80. Slots 80, 82 are formed to extend along planes that are generally parallel to one

another. An opening **84** in body **72** is formed between slots **80**, **82**. A first roller **86** is mounted in first slot **80**, and a second roller **88** is mounted in second slot **82**. Preferably, each roller has a rotational axis that is generally parallel with the rotational axis of the other roller and which axii are generally perpendicular to the planes along which the slots **80**, **82** are formed. In one embodiment, roller **86** is of a larger diameter than roller **88** because roller **86** is utilized primarily to transfer the load from piston **30** to the adjacent cam **18**. An adjustable spacer pad **90** may be mounted on arm **78** between rollers **86**, **88** and opening **84**. Spacer pad **90** is adjustable to move radially relative to axis **71**, towards or away from opening **84** in order to align cam follower assembly **26** with a cam **18**. An internal lubrication passage **92** is defined and extends within arm **78**. Lubrication passage **92** is in fluid communication with a port **94** opening adjacent roller **86** so as to lubricate the bearings **87** of roller **86**; a port **96** opening adjacent roller **88** so as to lubricate the bearings **89** of roller **88**; and a port **98** disposed along the outer surface **100** of arm **78**. Cylindrically shaped second end **76** of body **72** may have a bore **102** formed therein, and may have one or more windows **104** opening into bore **102**.

Piston arm **28** is attached to cam follower assembly **26** at the first end **74** of body **72**. Piston arm **28** may be formed of a first annular body **110** spaced apart from a second annular body **112** of similar diameters and interconnected by a smaller diameter neck **114**. Neck **114** may be solid or have a bore formed therein, but is of a smaller diameter so as to form an annulus **116** between spaced apart bodies **110**, **112**. At least one, and preferably two or more, annular grooves **118** are formed around first annular body **110** for receipt of a seal ring (not shown). Likewise, at least one, and preferably two or more, annular grooves **120** are formed around second annular body **112** for receipt of a seal ring (not shown). Piston arm **28** utilizes two annular bodies **110**, **112** spaced apart from one another along neck **114** to minimize migration of combustion gases, unburned fuel and particulate matter into sump casings **54** and **56**, often referred to as the blowby effect.

With reference to FIG. 4B and ongoing reference to FIG. 4A, piston **30** is generally formed of an annular body **122** having a first end **124** attached to piston arm **28**. A crown **126** is formed at the second end **128** of annular body **122**. An indentation **130** may be formed in crown **126** and have a depth H1. Indentation **130** may be conically shaped in some embodiments. Likewise, in some embodiments, a notch **123** is formed at the periphery of annular body **122** and extends inward to intersect indentation **130**. In some embodiments, notch **123** preferably has a depth H2 no deeper than depth H1 of indentation **130** formed in crown **126**. Likewise, in some embodiments, notch **123** extends no more than approximately 90 degrees  $\theta$  around the periphery of annular body **122**, while in other embodiments, notch **123** extends no more than approximately 60 degrees  $\theta$  around the periphery of annular body **122**, while in other embodiments, notch **123** extends between 5 and 30 degrees  $\theta$  around the periphery of annular body **122**.

With reference to FIG. 5a, harmonic barrel cams **18a**, **18b** are shown in more detail mounted on driveshaft **12**. As described above, driveshaft **12** extends along a driveshaft axis **14** between a driveshaft first end **46** and a driveshaft second end **50**. Barrel cams **18a**, **18b** are mounted along driveshaft **12** in spaced apart relation to one another. Each cam **18** includes a cam hub **136** formed about a hub axis which cam hub **136** is mounted on driveshaft **12** to be coaxial therewith. Each cam **18** further includes a circumferential cam shoulder **138** extending around the periphery

of cam hub **136**. Cam shoulder **138** is generally of a curvilinear shape and can be characterized as having a certain frequency, where frequency may generally refer to the number of occurrences of peaks and troughs about the 360 degree circumference of shoulder **138**, a peak and abutting troughs together forming a lobe.

In one or more embodiments, the amplitude of the peaks of each cam shoulder **138** of each cam **18a**, **18b** are the same, with the depth of the troughs and the height of the peaks being substantially equal, while in other embodiments, the depth of the troughs may differ from height of the peaks.

In the embodiment of FIG. 5a, each curvilinear shaped cam shoulder **138** extending around cam hub **136** is illustrated with two peaks, namely a first peak **140a** and a second peak **140b**, with a corresponding number of troughs **141** formed therebetween, such as a first trough **141a** and a second trough **141b**. As such, the illustrated shoulder **138** creates two complete cycles about the 360 degree circumference of cam hub **136** and thus represents double harmonics. In other embodiments, shoulder **138** may have a different number of peaks **140** and troughs **141**. In other words, the frequency of the curvilinear shape forming shoulder **138** may be selected to exhibit the desired number of peaks **140** and troughs **141**.

Shoulder **38** is further characterized as having an inwardly facing track or surface **142** and an outwardly facing track or surface **144** and an outer circumferential surface **145**. Each cam **18a**, **18b** may be mounted on driveshaft **12** so as to be aligned with a driveshaft index reference **146**. In particular, each cam **18** may include a cam index **150**, such as the first cam index **150a** and second cam index **150b** of cams **18a**, **18b**, respectively.

In one or more embodiments, cams **18a**, **18b** are generally mounted on driveshaft **12** so that the indexes **150a**, **150b** are generally aligned with one another relative to a specific reference point **146** on driveshaft **12**. When the indices **150a**, **150b** are aligned with one another, the opposing cams **18a**, **18b** mirror one another and the respective peaks **140** of the two cams **18a**, **18b** align with one another, meaning that the respective peaks and troughs occur at the same angular position about driveshaft **12** relative to reference point **146**. As such, the peaks **140** of each cam **18a**, **18b** face one another and the troughs **141** of each cam **18a**, **18b** face one another. For the avoidance of doubt, references to cams **18** "mirroring" one another herein simply mean that the respective troughs or peaks occur at the same angular position about driveshaft **12**, but not necessarily that the curvilinear shape of the shoulders **138a**, **138b** are the same.

Finally, the top of each peak **140** corresponds with inner dead center (IDC) of combustion cylinder assembly **24** (see FIG. 3), while the bottom of each trough **141** corresponds with outer dead center (ODC) of combustion cylinder assembly **24**. In other words, when a cam follower **26** (see FIG. 4A) engages a shoulder **138** at a lobe peak **140**, the piston **30** (see FIG. 4A) driven by the cam follower **26** is at IDC of combustion cylinder **60** (see FIG. 3). Likewise, when a cam follower **26** (see FIG. 4A) engages a shoulder **138** at a trough **141**, the piston **30** (see FIG. 4A) driven by the cam follower **26** is at ODC of combustion cylinder **60** (see FIG. 3).

FIGS. 5b and 5c are cam profiles of cam shoulders **138a**, **138b** to better illustrate various embodiments of the curvilinear shape of cam shoulders **138a**, **138b**. In one or more embodiments as illustrated in FIG. 5b, the curvilinear shape may be a sinusoidal shape, with a peak occurring equidistance between successive troughs, while in other embodiments as illustrated in FIG. 5c, the curvilinear shape may be

a segmented polynomial shape, with the peak occurring between two successive troughs and skewed or shifted closer to one trough. In any event, cam shoulder **138a** may be associated with the intake cam **18a** and cam shoulder **138b** may be associated with the exhaust cam **18b**. Each shoulder **138** forms a guide or track along which a cam follower (see FIG. 4A) moves. As such, the shape of the shoulder **138** governs movement of a corresponding piston within a combustion cylinder, such as combustion cylinder **60** described above. The shoulder shape, as represented by the profiles of FIGS. 5a, 5b is therefore an important part of the operation of some embodiments of engine **10**.

It will be appreciated that cam shoulders **138a**, **138b** are illustrated in FIGS. 5b and 5c as they would oppose one another on driveshaft **12** when radially indexed to substantially mirror one another. As such, peaks **140** oppose one another and troughs **141** oppose one another so that the opposing features have approximately the same radial position on driveshaft **12** relative to the driveshaft index **146** (see FIG. 5). Generally, each cam **18** has at least one lobe **151** formed of a peak **140** bounded by a trough **141**. In the illustrated embodiment, each cam **18** is shown with a first lobe and a second lobe. Each peak **140** has a maximum peak amplitude PA. Each lobe **151** has an overall wavelength distance W, defined as the distance between successive troughs **141** across a peak **140**. Each trough has a maximum trough depth TD. Moving clockwise along the circumference of a cam shoulder **138** (or left to right as shown in FIGS. 5b and 5c), each lobe **151** has an ascending side or shoulder portion **153** and a descending side or shoulder portion **155**.

Additionally, to ensure that the opposing pistons driven by cams **18a**, **18b** are continuously moving, no portion of the curvilinear shaped shoulder of cam **18a** is parallel with any portion of curvilinear shaped shoulder of cam **18b**. As such, opposing curvilinear shaped shoulders **138a**, **138b**, whether of a sinusoidal shape or a segmented polynomial shape, are constantly diverging or converging from one another. In other words, no portion of shoulders **138a**, **138b** are parallel since this would result in a loss of momentum of movement of the opposing pistons within the combustion chamber in which they are disposed, which in turn would result in a loss of engine torque.

With specific reference to FIG. 5b, cam **18a** is shown as having a sinusoidal shaped cam shoulder **138a**. As such, first lobe **151a1** is located approximately equidistance between a first trough **141a1** and a second trough **141a2**. In particular, the maximum peak amplitude PAa1 occurs at approximately  $\frac{1}{2}$  the overall wavelength distance W for lobe **151a1**. As such, first lobe **151a1** is symmetrical in shape, illustrated by wavelength distance Was of an ascending shoulder portion **153a1** from the first trough **141a1** to the peak or apex **143a1** of lobe **151a1** being equal to the wavelength distance Wds of descending shoulder portion **155a1** from the peak or apex **143a1** of lobe **151a1** to second trough **141a2**. First trough **141a1** has a trough depth TDa1 that is substantially the same as trough depth TDa1 of second trough **141a2**. Similarly, second lobe **151a2** is of substantially the same shape as first lobe **151a1**. In this regard, lobe **151a1** has an ascending shoulder portion **153a1** that is of substantially the same shape as descending shoulder portion **155a1**. As such, the absolute value of the average slope Sa1 of ascending shoulder portion **153a1** between trough **141a1** and peak **140a1** is approximately the same as the absolute value of the average slope Sa2 of descending shoulder portion **155a1** between peak **140a1** and trough **141a2** moving clockwise along shoulder **138a**.

As with cam **18a**, cam **18b** is shown as having a symmetrical sinusoidal shaped cam shoulder **138b**. As such, first lobe **151b1** is located approximately equidistance between a first trough **141b1** and a second trough **141b2**. In particular, the maximum peak amplitude PAb1 occurs at approximately  $\frac{1}{2}$  the overall wavelength distance W for lobe **151b1**. First trough **141b1** has a trough depth TDb1 that is substantially the same as trough depth TDb1 of second trough **141b2**. Similarly, second lobe **151b2** is of substantially the same shape as first lobe **151b1**. In this regard, lobe **151b1** has an ascending shoulder portion **153b1** that is of substantially the same shape as descending shoulder portion **155b1**. As such, the absolute value of the average slope Sb1 of ascending shoulder portion **153b1** between trough **141b1** and peak **140b1** is approximately the same as the absolute value of the average slope Sb2 of descending shoulder portion **155b1** between peak **140b1** and trough **141b2** moving clockwise along shoulder **138b**.

In any event, cams **18a**, **18b** are angularly mounted on driveshaft **12** (see FIG. 5a) to mirror one another so that the lobes **151** of the respective cams opposed one another with corresponding peaks **140** in general alignment and the number of lobes **151a** of cam **18a** corresponds with the number of lobes **151b** of cam **18b**. In this regard, the opposing features may be angularly aligned with one another so that opposing peaks **140** and opposing troughs **141** generally occur at the same angular position about driveshaft **12** relative to index **146**.

Although in some embodiments, the opposing shoulders **138a**, **138b** of spaced apart cams **18a**, **18b** are generally disposed to have substantially the same sinusoidal shape, adjustments to portions of the shape of a particular shoulder, including the width of circumferential surface **145** and/or the shape of inwardly facing track **142** of a shoulder **138** may be utilized to adjust relative movements of opposing first and second piston assemblies **22a**, **22b**, respectively, for a desired purpose. Thus, in some embodiments, the trough **141a1** of one cam **18a** may be shaped to include a flat portion **147** that lies in a plane perpendicular to axis **14** and the axis of cam hub **136** or otherwise be deeper than the corresponding opposing trough **141b1** of cam **18b**, which is illustrated as generally curved through the entire trough **141b1**. In other words, the trough depth TDb1 of trough **141b1** is greater than opposing trough depth TDa1 of corresponding trough **141a1**. Similarly, peak **140a1** of cam **18a** may have a rounded shape at its apex **143**, while the shape of opposing peak **140b1** of cam **18b** may have a flat portion **149** that lies in a plane perpendicular to axis **14** and the axis of cam hub **136** at its corresponding apex **143**. In the illustrated embodiments, because each flat portion **147**, **149** of the corresponding cams **18a**, **18b** lies in a plane perpendicular to axis **14** and the axis of cam hub **136**, it will be appreciated that flat portions **147**, **149** are in parallel planes.

With specific reference to FIG. 5c, cam **18a** is shown as having a segmented polynomial shaped cam shoulder **138a**. As such, first lobe **151a1** is asymmetrical in shape, with the maximum peak amplitude PAa1 occurring closer to second trough **141a2** as opposed to first trough **141a1**, illustrated by wavelength distance Was from the first trough **141a1** to the apex **143** of lobe **151a1** as being greater than the wavelength distance Wds from the apex **143a1** of lobe **151a1** to second trough **141a2**. In other words, wavelength distance Was from the first trough **141a1** to peak **143a1** of an ascending shoulder portion **153a1** of lobe **151a1** is greater than the wavelength distance Wds from the peak **143a1** to the second trough **141a2** of a descending shoulder portion **155a1** of the lobe **151a1**. In these embodiments, first trough **141a1** has a

trough depth TDa1 that is substantially the same as trough depth TDa2 of second trough 141a2, which is substantially the same as maximum peak amplitudes PAa1 and PAa2 of lobes 151a1 and 151a2, respectively. Similarly, second lobe 151a2 is of substantially the same shape as first lobe 151a1. However, because lobes 151a1 and 151a2 are asymmetrical, lobe 151a1 has an ascending shoulder portion 153a1 that is shallower in shape than the steeper shape of descending shoulder portion 155a1. As such, the absolute value of the average slope Sa1 of ascending shoulder portion 153a1 between trough 141a1 and peak 140a1 is less than the absolute value of the average slope Sa2 of descending shoulder portion 155a1 between peak 140a1 and trough 141a2 moving clockwise along shoulder 138a. It will be appreciated that the steeper shape (or greater slope) of descending shoulder portion 155a1 results in faster movement of a corresponding piston during the exhaust stroke of engine 10 as compared to the intake stroke.

Cam 18b is shown in FIG. 5c as having a segmented polynomial shaped cam shoulder 138b. As such, first lobe 151b1 is asymmetrical in shape, with the maximum peak amplitude PAb1 occurring closer to second trough 141b2 as opposed to first trough 141b1, illustrated by wavelength distance Was from the first trough 141b1 to the apex 143b1 of lobe 151b1 as being greater than the wavelength distance Wds from the apex 143b1 of lobe 151b1 to second trough 141b2. In these embodiments, first trough 141b1 has a trough depth TDb1 that is substantially the same as trough depth TDb2 of second trough 141b2, which is substantially the same as maximum peak amplitudes PAb1 and PAb2 of lobes 151b1 and 151b2, respectively. Similarly, second lobe 151b2 is of substantially the same shape as first lobe 151b1. However, because lobes 151b1 and 151b2 are asymmetrical, lobe 151b1 has an ascending shoulder portion 153b1 that is shallower in shape than the steeper shape of descending shoulder portion 155b1. As such, the absolute value of the average slope Sb1 of ascending shoulder portion 153b1 between trough 141b1 and peak 140b1 is less than the absolute value of the average slope Sb2 of descending shoulder portion 155b1 between peak 140b1 and trough 141b2 moving clockwise along shoulder 138b.

In any event, cams 18a, 18b are angularly mounted on driveshaft 12 relative to index 146 (see FIG. 5a) to mirror one another so that the lobes 151 of the respective cams opposed one another with corresponding peaks 140 in general alignment and the number of lobes 151a of cam 18a corresponds with the number of lobes 151b of cam 18b. In this regard, the opposing features may be angularly aligned with one another so that opposing peaks 140 and opposing troughs 141 generally occur at the same angular position about driveshaft 12 relative to index 146.

In one or more embodiments, each descending shoulder portion 155 of a segmented polynomial shaped cam shoulder 138 further includes a substantially linear portion 157 extending from each lobe apex 143 toward the second trough 141. While portion 157 may be linear or flat, it will be appreciated that it is not perpendicular to axis 14 or the axis of cam hub 136 (and thus, a piston continues to move as its associated cam follower moves across linear portion 157 during operation of engine 10.) In other words, linear portion 157 has a slope greater than zero. In preferred embodiments, linear portion 157 has a slope of greater than zero and less than approximately 20 degrees. Thus, descending shoulder portion 155a1 of lobe 151a1 of cam 18a includes a linear portion 157a1 extending from apex 143a1. Similarly, opposing cam 18b has a descending shoulder portion 155b1 of lobe 151b1 with a linear portion 157b1

extending from apex 143b1. The other lobes 151a2, 151b2 likewise include linear portions 157 as described. In one or more embodiments, opposing linear portions 157 have the same slope. In one or more embodiments, at least one, or both ascending shoulder portion 153 of a segmented polynomial shaped cam shoulder 138 may likewise include a substantially linear portion (not shown) similar to linear portion 157, extending from each lobe trough 141 extending towards an apex 143. Again, while such portion may be linear or flat, it will be appreciated that it is not perpendicular to axis 14 or the axis of cam hub 136, and thus, a piston continues to move as its associated cam follower moves across such linear portion and the slope of such portion would be greater than zero.

The shoulders 138a, 138b of spaced apart cams 18a, 18b illustrated in FIG. 5c are generally disposed to have substantially the same segmented polynomial shape at least along the opposing descending shoulder portions 155a1, 155a1. However, because the shape of the segmented polynomial shoulder governs opening and closing of the intake and exhaust ports, and in particular, how fast a piston moves within its combustion cylinder to open or close a port, then the opposing ascending shoulder portion 153 of cams 18a, 18b may differ. As such, the in one or more embodiments, the discrete slope Sa1 at any given point along the ascending shoulder portion 153a1 of cam 18a may differ from the discrete slope Sb1 at any given point along the ascending shoulder portion 153b1 of cam 18b. For example, the initial shape of ascending shoulder portion 153b1 adjacent trough 141b1 may be steeper than the initial shape of ascending shoulder portion 153a1 adjacent trough 141a1, resulting in faster movement of the exhaust piston back towards IDC and thus faster closing of the exhaust port as compared to the intake port associated with the intake piston movement governed by ascending shoulder portion 153a1. Regardless, it will be appreciated that for the overall segmented polynomial shape of opposing shoulders 138a, 138b, the trough depth TDa1 of trough 141a1 is substantially the same as the opposing trough depth TDb1 of corresponding trough 141b1. Similarly, peak 140a1 of cam 18a has substantially the same peak amplitude PAa1 as the peak amplitude PAb1 of opposing peak 140b1.

The length L of linear portion 157 may be selected to correspond with a particular type of fuel. It will be appreciated that while opposing shoulders 138a, 138b are constantly diverging or converging without any parallel portions of their respective segmented polynomial shapes, the opposing linear portions 157 of a shallow slope result in slower movement apart of opposing cams in a combustion cylinder, thereby permitting a substantially constant combustion chamber volume for a period of time without having the pistons stop in the combustion cylinder. In one or more embodiments, opposing linear portions 157 have the same length L. However, it will be appreciated that in this embodiment, while the peak 140a of each lobe 151a of cam 18a is substantially aligned with the corresponding peak 140b of each lobe 151b of cam 18b, no portion of segmented polynomial shaped shoulder 138a is parallel with any portion of segmented polynomial shaped shoulder 138b.

Likewise, the angular alignment of cams 18a, 18b relative to the driveshaft index reference 146, and also to one another may be adjusted to achieve a particular purpose. Cam 18a may be angularly rotated a desired number of degrees relative to driveshaft index reference 146 (and cam 18b) in order to adjust the movement of the piston 30 associated with cam 18a relative to the piston 30 associated with cam 18b. In some embodiments, one cam 18, such as cam 18b,

may be rotated approximately 0.5 to 11 degrees relative to the other cam **18**, such as cam **18a**.

In any event, in one or more embodiments, cam shoulders **138a**, **138b** are shaped and positioned on driveshaft so that the engine **10** has the following configurations of an intake piston and opposing exhaust piston, an intake port and an exhaust port at different stages of the combustion and expansion strokes relative to the point of engagement of a cam follower with a cam shoulder:

- (1) at the apex **143** of cam shoulder **138**, opposing intake and exhaust pistons are at inner dead center (IDC) within a combustion cylinder and both exhaust port and intake port are closed;
- (2) along the linear portion **157** of a descending shoulder portion **155**, the intake and exhaust ports remained closed and intake and exhaust pistons retract slowly away from one another (and from IDC) in the combustion cylinder, the shallowly sloped linear portions **157** allowing an almost constant volume within the combustion cylinder to be maintained during combustion but without stopping movement of the pistons;
- (3) further along descending shoulder portion **155**, due to the steep slope, opposed intake and exhaust pistons retract more quickly from one another, the retraction of the exhaust piston opening an exhaust port to allow scavenging of exhaust gases while intake port remains closed (because the inner edge **67** of the exhaust port **36** is closer to IDC than the inner edge **63** of intake port **38**) (see FIG. 3);
- (4) further along descending shoulder portion **155**, approaching the bottom of the second trough **141**, as opposed intake and exhaust pistons continue to retract from one another, the intake port is opened by virtue of movement of the intake piston;
- (5) at the base of the second trough, the intake and exhaust piston reach outer dead center (ODC) within the combustion cylinder, with both intake and exhaust ports open;
- (6) in one or more embodiments, the exhaust piston initially moves from ODC to IDC more quickly than the intake piston because the ascending shoulder portion **153b<sub>1</sub>** of the cam shoulder **138b** driving the exhaust piston is steeper adjacent the trough **141b<sub>1</sub>** than the corresponding ascending shoulder portion **153a<sub>1</sub>** of the cam shoulder **138a** adjacent the trough **141a<sub>1</sub>** associated with the intake piston, the result being that the exhaust port adjacent the exhaust piston closes earlier than the intake port adjacent the intake piston (which closes more slowly since the ascending portion **153a<sub>1</sub>** adjacent trough **141a<sub>1</sub>** that drives the intake piston is shallower);
- (7) as the respective cam followers continue to move along the respective ascending portions **153** of the cam shoulders **138**, the intake piston (which was lagging behind the exhaust piston in their respective movement towards each other and IDC) catches up with the exhaust piston so that the pistons reach the apex **143** of their respective cam shoulders **138** at the same time, the intake piston, having remained at least partially open while the exhaust piston was fully closed, also is closed by the intake piston.

FIG. 6 illustrates a piston assembly **22** engaged with cam **18a**. Specifically, body **72** of cam follower assembly **26** engages cam **18a** so that the shoulder **138** of cam **18a** extends into opening **84** of cam follower assembly **26**, allowing first roller **86** to engage inwardly facing track **142** of cam **18a** and second roller **88** to engage outwardly facing

track **144** of cam **18a**. Adjustable spacer **90** bears against outer surface **145** of shoulder **138**. Spacer **90** can be radially adjusted to correspondingly adjust the position and alignment of rollers **86**, **88** on tracks **142**, **144**, respectively. Piston assembly **22** is constrained to reciprocate along axis **71** which is spaced apart from driveshaft axis **14** a distance **D**. Axial movement of piston assembly **22** along axis **71** is translated into rotational movement of driveshaft **12** about axis **14** by virtue of cams **18a** and **18b**. In the illustrated embodiment, it will be appreciated that the shape of shoulder **138** is generally sinusoidal and peak **140a** of cam **18a** has a rounded shape at its apex **143**, while the corresponding surface of peak **140a** of cam **18b** has a linear or flat portion **149** (as described above) at its apex **143**. In other embodiments, the shoulder **138** may have a segmented polynomial shape, in which case, opposing peaks **140** would be rounded at apex **143** of both cams **18** and opposing troughs **141** would likewise be similarly rounded at their bottom.

FIGS. **7a** and **7b** illustrate cylinder assemblies **24** symmetrically positioned around driveshaft **12**. While cylinder assemblies **24** are generally supported by engine block **53** (see FIG. 1), for ease of depiction, the engine block **53** is not shown in FIGS. **7a** and **7b**. In one embodiment, six cylinder assemblies **24a**, **24b**, **24c**, **24d**, **24e** and **24f** are utilized, although fewer or more cylinder assemblies **24** could be incorporated as desired. In any event, the cylinder assemblies **24a-24f** are positioned around driveshaft **12** between cams **18a**, **18b**. It will be understood that while a piston pair **20** is only illustrated as being engaged with cylinder assembly **24a** for ease of description, each cylinder assembly **24** includes a piston pair **20**. In any event, a first piston assembly **22a** and a second piston assembly **22b** which piston assemblies **22a**, **22b** are axially aligned with one another within a cylinder assembly **24a**. Cams **18a**, **18b** are mounted on driveshaft **12** so that the cams **18a**, **18b** are aligned to generally mirror one another. Each piston assembly **22** within combustion cylinder **60** moves between ODC (where each piston is adjacent a respective port outer edge **61**, **65** as shown in FIG. 3) to a position adjacent IDC where combustion occurs. Combustion within cylinder **60** of cylinder assembly **24a** drives first piston assembly **22a** and second piston assembly **22b** away from one another along the axis **71** of cylinder assembly **24a** towards ODC. Cylinder **60** constrains each piston assembly **22a**, **22b** to axial reciprocation along axis **71**. This axial movement of piston assemblies **22a**, **22b** along axis **71** is translated by cams **18a** and **18b** into rotational movement of driveshaft **12** about axis **14** as the rollers **86**, **88** of respective cam follower assemblies **22a**, **22b** moves along the tracks **142**, **144** of their respective cams **18a**, **18b**.

While cams **18a**, **18b** generally mirror one another, as explained above, in some embodiments where shoulder **143** has a sinusoidal shape, the trough **141a** of cam **18a** may be shaped to include a flat portion **147** (a portion that lies in a plane perpendicular to axis **14**) relative to corresponding opposing trough **141b** of cam **18b**, which is illustrated as generally curved through the entire trough **141b**, causing piston **30a** to have a different momentary displacement in cylinder **60** relative to piston **30b**. In particular, as shown, as cam follower **22a** reaches flat portion **147** of track **142** of cam **18a**, piston **30a** will remain retracted at outer dead center ("ODC") momentarily even as piston **30b** continues to translate as its cam follower **22b** moves along track **142** of cam **18b**. In the illustrated embodiment, it will be appreciated that this allows intake ports **38** to remain open while exhaust ports **36** are closed by the proximity of piston **30b** to exhaust ports **36**. A similar phenomenon occurs when cam

followers **22a**, **22b** reach an apex **143** of their respective cams **18a**, **18b**. As described, the apex **143b** of cam **18b** includes a flat portion **149** (a portion that lies in a plane perpendicular to axis **14**) relative to corresponding opposing apex **143a** of cam **18a**, which is illustrated as generally curved through the entire apex **143a**, causing piston **30b** to have a different displacement in cylinder **60** relative to piston **30a**. In particular, as cam follower **22b** reaches flat portion **149** of track **142** of cam **18b**, piston **30b** will remain fully extended at inner dead center ("IDC") momentarily even as piston **30a** continues to translate as its cam follower **22a** moves along track **142** of cam **18a**. It will be appreciated in other embodiments, it may be desirable to ensure that each piston **30** is continuously moving within combustion cylinder **60**, in which case, the shape of shoulder **143** does not include a portion that lies in a plane perpendicular to axis **14**. Thus, by utilizing the shape of shoulders **138** of opposing cams **18a**, **18b**, the relative translation of pistons **30a**, **30b** can be adjusted to achieve a desired goal, such as controlling the timing of opening or closing of ports **36**, **38**. In other words, the cams **18a**, **18b** control the timing for opening and closing of the ports **36**, **38** utilizing the curvilinear shape of shoulder **138** to provide desired timing for each opening and closing operation as the pistons translate across their respective ports.

In addition or alternatively to using the shape of shoulders **138** to adjust relative axial movement of pistons **30a**, **30b**, it will be appreciated that cam **18a** can be radially displaced on driveshaft **12** relative to cam **18b**, thereby achieving the same objective described above. Cams **18** may be located on driveshaft **12** with a small angular displacement with respect to each other in order to cause one of pistons **30** to be displaced in the cylinder **60** slightly ahead or behind its opposing piston **30**. This asymmetric piston phasing feature can be used to enhance scavenging operations, particularly as may be desirable when different fuel types are utilized within engine **10**.

It will be appreciated particularly with reference to FIG. **7b** that additional cylinder assemblies **24** may be symmetrically deployed about driveshaft **12** by simply increasing the diameter of cam shoulder **143**. In some embodiments, where high torque is required, cam shoulder **143** may be large, with a corresponding large plurality of cylinder assemblies **24**, but where each cylinder assembly has a much shorter stroke.

FIG. **8** illustrates the cylinder assemblies **24a-24f** and driveshaft **12** of FIG. **7a** in relation to engine block **53**. Thus, as shown, engine block **53** is positioned about driveshaft **12** between cam **18a** and cam **18b**. Engine block **53** is generally extends between a first end **162** and a second end **164** and includes an annular body portion **160** therebetween, which annular body portion **160** is characterized by an exterior surface **166**. Formed in body **160** is a first annular channel **168** and a second annular channel **170** spaced apart from one another. Although annular channels **168**, **170** may be formed internally of the exterior surface **166**, in the illustrated embodiment annular channels **168**, **170** extend from exterior surface **166** inwardly. Similarly, while the illustrated embodiment shows annular channels **168**, **170** extending around the entire circumference of cylindrical body **160**, in other embodiments, one or both annular channels **168**, **170** may extend only partially around the circumference of cylindrical body **160**. A central driveshaft bore **172** extends between ends **162**, **164**. Likewise, two or more symmetrically positioned cylinder bores **174** extend between ends **162**, **164** and are radially spaced outward of central drive-

shaft bore **172**, of which cylinder bores **174a**, **174b**, **174c** and **174f** are visible. Disposed in each cylinder bore **174** is a cylinder assembly **24**, and thus, illustrated are cylinder assemblies **24a**, **24b**, **24c** and **24f**. As such, block **53** supports the cylinder assemblies **24**. Each cylinder assembly **24** is positioned in block **53** so that its intake ports **38** are in fluid communication with the first annular channel **168** and that its exhaust ports **36** are in fluid communication with the second annular channel **170**. When so positioned, each first port **68** and each second port **70** of cylinder assembly **24** align with a first port **180** and a second port **182** provided in the exterior surface **166** of engine block **53**. Opposing cam follower assemblies **26a**, **26b** are illustrated as engaging their respective cams **18a**, **18b** and extending along axis **71** into the cylinder assembly **24a** supported in cylinder bore **174a** of engine block **53**.

One benefit of the engine of the disclosure, particularly with respect to engine block **53**, but also with respect to other engine components, is that it maintains a closed circuit of forces/reaction throughout an engine stroke, keeping all the stress, compression, pressures, moments and forces contained within the circuit, from the cylinder combustion chamber, to pistons, to rollers, cams and finally driveshaft. There is no lateral or unbalanced forces acting during operation, as always occur on crankshaft systems with its geometry naturally unbalanced and misaligned. The closed circuit of forces refers to the sequence of forces applied during each power stroke. This eliminates the need for heavy reinforced engine blocks, housings, bearing, driveshafts and other components. The sequence commences upon combustion, followed by burnt gases expansion creating a power stroke in opposed directions, applying aligned compressive forces on the pistons, transmitted to the cam follower assemblies engaging the cams, through the cams, where the reciprocating linear motion from the pistons became rotational motion on the cams that then returns as opposed, aligned compressive forces in the driveshaft. In other words, the expansion forces passing through the pistons are always aligned, as are the compressive forces applied to the driveshaft. This also significantly reduces the presence of engine vibrations during operation. In contrast, asymmetric forces are applied on conventional driveshafts during operation, which creates a variety of deflections and reactions that must be contained by the engine block, driveshaft and bearings through the use of heavier, stronger materials. By eliminating the need for such reinforced engine components, the engine block, driveshaft and other components of the engine of the disclosure may be formed of other materials that need only be utilized to support the engine components as opposed to withstand unbalanced forces. Such materials may include plastics, ceramics, glass, composites or lighter metals.

FIG. **9** illustrates the cylinder assemblies **24a-24f**, driveshaft **12**, cam follower assemblies **26a**, **26b**, cams **18a**, **18b** and engine block **53** of FIG. **8**, but with annular flow manifolds installed. In particular, a first annular manifold **184** is illustrated installed over and around first annular channel **168**. First annular manifold **184** may be an air intake manifold for supplying air to first annular channel **168** and intake ports **38** of the cylinder assemblies **24**. Also illustrated is a second annular manifold **186** installed over and around second annular channel **170**. Second annular manifold **186** may be an exhaust manifold for removing exhaust from cylinder assemblies **24** via exhaust ports **36** in fluid communication with second annular channel **170**.

Manifold **184** is generally formed of a toroidal shaped wall **190** in which a port **192** is formed. Likewise, manifold **186** is generally formed of a toroidal shaped wall **194** in which a port **196** is formed.

Also shown in FIG. 9 is a first guidance cap **198** deployed around driveshaft **12** between its first end **46** and cam **18a**, and a second guidance cap **200** deployed around driveshaft **12** between its second end **50** and cam **18b**. Each guidance cap **198, 200** generally includes a central bore **202** through which driveshaft **12** extends and two or more symmetrically positioned bores **204** radially spaced outward of central bore **202** with each bore **204** corresponding with and axially aligned with an adjacent cylinder assembly **24** supported by block **53**. In the illustrated embodiment, each guidance cap **198, 200** has six bores **204**, namely **204a, 204b, 204c, 204d, 204e** and **204f**, symmetrically spaced about central bore **202**. Each bore **204** is disposed to receive a cam follower assembly **26** to provide support to the cam follower assembly **26** as it reciprocates into and out of its respective cylinder assembly **24**. In particular, as shown, the bore **204** is sized to correspond with the smaller diameter cylindrical end **76** of body **72** forming cam follower assembly **26**, allowing the smaller diameter cylindrical end **76** to slide within bore **204** as piston **30** reciprocates in cylinder assembly **24**. In addition, one or both guidance caps **198, 200** may be utilized to inject lubricating and cooling oil into to port **98** of the cam follower assembly **26**. In particular, the guidance caps may be used to transfer the oil coming from an oil pump (not shown) to bearings **87, 89** of cam follower assembly **26**. Each guidance cap **198, 200** may include one or more ports **203** for connecting hole **203** that transfer the oil to port **98** of the cam follower assembly **26**.

FIG. 10 is a perspective view of engine assembly **10**. In the illustrated embodiment, engine block **53** is shown with annular air intake manifold **184** and annular exhaust manifold **186**.

A fuel injector assembly **208** is shown mounted in one of ports **180, 182** of the engine block **53**, while a sparkplug **210** is shown as mounted in the other of the ports **180, 182** of engine block **53**. Engine block **53** is supported by and partially encased by a first engine block support **212** at one end of the engine assembly **10** and engine block **53** is supported by and partially encased by a second engine block support **214** at the opposite end of the engine assembly **10**. In this regard, sump casing **54** cooperates with first engine block support **212** to enclose engine block **53** around the first end **46** of driveshaft **12** forming an oil lubrication and cooling chamber for providing oil to cam **18a** and its associated cam follower assemblies **26**, while sump casing **56** cooperates with second engine block support **214** to enclose engine block **53** around the second end **50** of driveshaft **12** forming an oil lubrication and cooling chamber for providing oil to cam **18b** and its associated cam follower assemblies **26**. An oil port **218** may be provided in each of engine block support **212, 214** or sump casing **54, 56**.

A first flange **44** is attached to a driveshaft **12** with a flywheel **52** mounted on first flange **44**.

An electric starter **219** may be provided to initiate rotation of driveshaft **12** (not shown).

In some embodiments, an air supply device **220**, may be used to introduce air into first annular manifold **184** via port **192** in wall **190**. Air supply device **220**, while not limited to a certain type, may be a turbocharger or blower in some embodiments to maintain positive air pressure in order to provide continuous new charges of air in each engine cycle.

In other embodiments, air supply device **220** may be eliminated and pulse jet effect, also known as the Kadenacy effect, may be utilized to draw combustion air into cylinder assembly **24** (as opposed to air supply device **220** or retraction movement of a hot piston assembly **22**). More specifically, if the period of opening and closing of the exhaust ports **36** is less than a 300th of a second, the speed of the exhaust gas exchange from the cylinder assembly **24** to atmosphere is extremely rapid. This rapid opening and closing of the exhaust ports **36** of a cylinder assembly **24**, just before the air intake port **38** is opened, added by a specific exhaust port area to piston bore ration, will produce the pulse jet effect. This effect can be mechanically achieved by the engine of the disclosure using the phasing of cams **18** as described above, in conjunction with the timing of the exhaust port cam to speed up the hot piston when traveling through open/closing the exhaust port, and holding the cold piston in a opened air intake port just after closing exhaust port. This can be achieved by using curvilinear shaped cam shoulders to control cam phasing.

Turning to FIGS. **11a-11k**, the operation of engine assembly **10** will be described with reference to a system of four cylinder assemblies **24**, of which cylinder assembly **24a** will be the primary focal point, with references to cylinder assemblies **24b** and **24d**. Generally depicted is driveshaft **12** on which is mounted cams **18a** and **18b**, each having a curvilinear shaped shoulder **138**. In the illustrated embodiment, each of cams **18a, 18b** has two lobes **151** formed by two peaks **140** and two troughs **141** and are disposed on driveshaft so as to be radially aligned, i.e., without a radial offset of one cam **18** relative to the other cam. A cam follower assembly **26a** engaged cam **18a** and a cam follower assembly **26b** engages cam **12b** so that roller **86** of the respective cam follower assemblies **26a, 26b** engage the inwardly facing track **142** of the shoulder **38** of each cam **18a, 18b**. Cam follower assembly **26a** reciprocates a piston arm **28a** and piston **30a** within cylinder **60** of cylinder assembly **24a**, while cam follower assembly **26b** reciprocates a piston arm **28b** and piston **30b** within cylinder **60**. First guidance cap **198** supports cam follower assembly **26a** while second guidance cap **200** supports cam follower assembly **26b**. Movement of piston **30a** within cylinder **60** will be described relative to intake ports **38** formed in cylinder **60**. Movement of piston **30b** within cylinder **60** will be described relative to exhaust ports **36** formed in cylinder **60**. The area between opposing pistons **30a, 30b** within cylinder **60** forms combustion chamber **32**. Inner dead center (IDC) and outer dead center (ODC) relative to the piston **30** for cylinder assembly **24a** are indicated.

FIG. **11a** illustrates the pistons **30a, 30b** at IDC, wherein each piston **30a, 30b** is at its innermost axial position within cylinder **60**. In this position, each cam follower **26a, 26b** engages its respective cam **12a, 12b** at a peak **140**. In this position, intake ports **38** are in a "closed" configuration, whereby the piston head **30a** is positioned between IDC of cylinder assembly **24a** and intake ports **38**, thereby blocking flow of combustion air combustion chamber **32**. Likewise, exhaust port **36** is in a "closed" configuration, in that piston head **30b** is positioned between IDC of cylinder assembly **24a** and exhaust port **36**, thereby blocking fluid communication between combustion chamber **32** and exhaust port **36**. In this position, driveshaft **12** is illustrated as being at a reference angle of 0°. Intake port **38** and exhaust port **36** (as highlighted by the boxes) are closed, with the piston **30** between the ports **38, 36** and the center of the cylinder **60**.

In FIG. **11b**, combustion occurs within combustion chamber **32**, initiating the expansion stroke and applying an axial

17

force (as indicated by the arrows) to each of pistons **30a**, **30b**. At the point of the expansion stroke, intake port **38** and exhaust port **36** (as highlighted by the boxes) are still closed, with the piston **30** between the ports **38**, **36** and the center of the cylinder **60**.

In FIG. **11c**, with the expansion of the combustion gases within cylinder **60**, pistons **30a**, **30b** begin to move axially away from one another (as shown by the arrows). This in turn forces each cam follower assembly **26a**, **26b** to begin to move along a descending portion of the shoulder track of their respective cams **18a**, **18b**. In doing so, the axial motion of the cam follower assembly **26** is converted to rotational motion of driveshaft **12**. At this point in the expansion stroke, both ports **36**, **38** remain closed by virtue of the proximity of the piston heads **30a**, **30b** to the respective ports. Although pistons **30a**, **30b** have begun to move, at the point of the expansion stroke, intake port **38** and exhaust port **36** are still closed by virtue of the proximity of piston **30a**, **30b** to ports **38**, **36**, respectively. As described above, the speed of movement of the respective pistons can be adjusted by adjusting the slope of the descending portion

In FIG. **11d**, as the expansion stroke continues, piston **30b** has translated a sufficient distance towards cam **18b** that exhaust port **36** begins to open, releasing exhaust air through port **36** (although port **36** is not fully open). Because exhaust port **36** has an inner port edge **67** (see FIG. **3**) that is closer to IDC than the inner port edge **63** (see FIG. **3**) of the intake port **38**, intake port **38** remains closed by virtue of the position of the port **38** relative to piston head **30a**. As can be seen, roller **86** of cam follower assembly **26b** has begun to move toward a trough **141** of cam **18b** along a descending portion of cam shoulder **138**.

In FIG. **11e**, piston **30b** has translated a sufficient distance towards cam **18b** that exhaust port **36** is fully open, releasing exhaust through exhaust port **36**. In addition, piston **30a** has translated a sufficient distance towards cam **18a** that intake port **38** begins to open, allowing air to flow into combustion chamber **32** via port **38** (although port **38** is not fully open). In some embodiments where port **38** comprises a plurality of angled slots, the angled nature of the slots and the length of the slots themselves causes air to begin to swirl as it enters combustion chamber **32**, thereby enhancing mixing of the air with fuel injected by a fuel injector (not shown). As noted above, in some embodiments, exhaust port **36** is comprised of a plurality of slots that extend only around a portion of the perimeter of cylinder **60** so as to minimize heat transfer to internal portions of engine assembly **10**. For example, such slots may extend only around that portion of the perimeter that is not adjacent or facing another cylinder **60**.

In FIG. **11f**, each piston **30a**, **30b** reaches ODC adjacent the outer port edges **61**, **65** of their respective ports **38**, **36** by virtue of cam follower assemblies **26a**, **26b** reaching the bottom of the troughs **141** of their respective cams **18a**, **18b**. When pistons **30a**, **30b** are at ODC, exhaust port **36** and intake port **38** are fully open, allowing exhaust to exit combustion chamber **32** and combustion air to enter combustion chamber **32**. The illustrated embodiment depicts cams **18a**, **18b** with substantially sinusoidal shaped shoulders **138a**, **138b**, and as such, as described above, it will be observed that on the intake side of the engine assembly **10**, a portion **147** of trough **141** of cam **18a** is flattened (as compared to opposing trough **141** of cam **18b** which is rounded).

In FIG. **11g**, piston **30b** begins to move, while piston **30a** remains stationary due to the flattened portion **147** of trough **141** of cam **18a** (as compared to opposing trough **141** of cam **18b** which is rounded). While piston **30a** temporarily

18

remains at ODC, the movement of piston **30b** begins closing off exhaust port **36**. The lag in timing between piston **30a** and piston **30b** permits additional combustion air to enter combustion chamber **32** since intake port **38** remains open when piston **30a** is at ODC.

In FIG. **11h**, both cam follower assemblies **26a**, **26b** are shown beginning to move along the ascending shoulder portion of their respective cam tracks **142** from trough **141** towards peak **140**, thus beginning the compression stroke. As illustrated, each piston **30a**, **30b** is still spaced apart from their respective port **38**, **36**, such that the ports are still open at this point in the stroke.

In FIG. **11i**, cam follower assembly **26b** has progressed farther along track **142** of cam **18b** than cam follower assembly **26a** has progressed along track **142** of cam **18a**. As such, exhaust port **36** is closed by piston **30b**, which is adjacent thereto. However, because piston **30a** along its track **142** lags behind piston **30b** on its respective track, intake port **38** remains open for a period of time after exhaust port **36** has closed, thus allowing additional combustion air to enter combustion chamber **32**. As noted above, intake port **38** may comprise a plurality of angled slots to promote swirl of the combustion air passing through port **38**.

In FIG. **11j**, both port **36**, **38** are shown as being in a “closed” configuration by their respective pistons **30a**, **30b**, which prevent fluid communication between chamber **32** and ports **36**, **38**. In addition, cam follower assembly **26b** has reached the apex **143** of peak **140** of track **142** of cam **18b**, causing exhaust piston **30b** to reach IDC. Because intake piston **30a** still lags behind exhaust piston **30b** at this point, intake piston **30a** continues to move (as indicated by the arrow), compressing the combustion air and fuel injected in chamber **32**. It will be observed that on the exhaust side of the engine assembly **10**, a portion **149** of apex **143** of cam **18b** is flattened (as compared to opposing apex **143** of cam **18a**), such that piston **30b** temporarily remains at IDC even while piston **30a** continues to move towards IDC. This lag by piston **30b** permits piston **30a** to “catch up” to piston **30b**, so that their movement along their respective tracks **142** at the beginning of the next stroke once again are synchronized and mirror one another (until piston **30a** reaches the bottom of the next trough **141**).

In FIG. **11k**, both pistons **30a**, **30b** have reached IDC and are once again synchronized with one another along their respective cams **18a**, **18b**. Being at IDC, combustion air and fuel in combustion chamber **32** are fully compressed for ignition. At this point, having progressed from expansion stroke, through compression stroke and back to expansion stroke, driveshaft **12** has rotated 180° from its original reference point describe in FIG. **11a**.

Turning to FIG. **12**, a cross-sectional view of a cylinder assembly **24** with a piston **30** extended to IDC as described above is shown. In particular, cylinder assembly **24** includes a cylinder **60** having a fuel injection aperture **68** into which a fuel injector **34** is mounted. A nozzle **35** of fuel injector **34** extends from wall **66** of cylinder **60** into the combustion chamber **32**. Piston **30** is shown in relation to nozzle **35**. Piston **30** has a crown **126** in which an indentation **130** is formed. Piston **30** is aligned within cylinder **60** so that fuel injector nozzle **35** is adjacent notch **123** formed at the periphery of crown **126**. Notch **123** prevents piston **30** from contacting fuel injector nozzle **35** when piston **30** is at IDC. It has been found that in certain embodiments, it is desirable for fuel injector nozzle **35** to extend into combustion chamber **32** because heat within combustion chamber **32** can be utilized to pre-heat fuel in nozzle **35** before the fuel is injected into combustion chamber **32**. By preheating fuel

within fuel injector nozzle **35**, combustion of the fuel within combustion chamber **32** is enhanced once the preheated fuel is injected into combustion chamber **32**.

Turning to FIG. **13**, an alternative embodiment of engine assembly **10** is illustrated, wherein two or more piston pairs **200**, such as piston pairs **200a**, **200b**, are axially aligned in series along cylinder axis **25**, together forming a piston series **202**, such as piston series **202a**. Specifically, in FIG. **13**, driveshaft **12** extends along a driveshaft axis **14** and passes axially through the center of the engine assembly **10**. Driveshaft **12** is supported by a pair of bearings **16a**, **16b** in a fixed axial position. Positioned along driveshaft **12** in spaced apart relationship to one another are at least three harmonic barrel cams **218a**, **218b**, **218c**, such as the barrel cams **18** described above. Each piston pairs **200** is comprised of a first piston assembly **222a** and a second piston assembly **222b** which piston assemblies **222a**, **222b** are axially aligned with one another within a combustion cylinder assembly **224a** disposed along a cylinder axis **25**. Cylinder axis **25** is spaced apart from but generally parallel with driveshaft axis **14** of driveshaft **12**. Piston assembly **222a** includes a cam follower assembly **226a** attached to a piston arm **228a** to which is mounted a piston **230a**. Likewise, opposing piston assembly **222b** includes a cam follower assembly **226b** attached to a piston arm **228b** to which is mounted a piston **230b**. The opposed pistons **230a**, **230b** of piston pair **200a** are adapted to reciprocate in opposite directions along cylinder axis **25**. Each cam follower assembly **226a**, **226b** straddles its respective cam **218a**, **218b** and acts on its respective piston **230a**, **230b**. Opposed pistons **230a**, **230b** within cylinder assembly **224a** generally define a combustion chamber **232a** therebetween into which fuel may be injected by fuel injector **234a**.

Piston pair **200b** of piston series **202a** likewise includes a first piston assembly **222c** and a second piston assembly **222d** which piston assemblies **222c**, **222d** are axially aligned with one another within a combustion cylinder assembly **224b** disposed along a cylinder axis **25**. Piston assembly **222c** includes a piston arm **228c** to which is mounted a piston **230c**. Opposing piston assembly **222d** includes a cam follower assembly **226d** attached to a piston arm **228d** to which is mounted a piston **230d**. The opposed pistons **230c**, **230d** of piston pair **200b** are adapted to reciprocate in opposite directions along cylinder axis **25**. Opposed pistons **230c**, **230d** within cylinder assembly **224b** generally define a combustion chamber **232b** therebetween into which fuel may be injected by fuel injector **234b**.

Thus, combustion cylinder assembly **224a** is axially aligned with combustion cylinder assembly **224b** so as to be in series along cylinder axis **25**.

Piston assembly **222c** further includes a cam follower bridge **227** interconnecting piston arm **228c** to cam follower assembly **226b** of piston assembly **222b**. Each cam follower assembly **226a**, **226b**, **226d** straddles its respective cam **218a**, **218b**, **218c** and is movable with respect to its respective cam **218a**, **218b**, **218c** so that axial movement of pistons **230a**, **230b** and **230d** can be translated into radial rotation of the respective cams **218a**, **218b**, **218d** so as to rotate driveshaft **12**. Further, because cam follower bridge **227** interconnects piston assembly **222b** and **222c**, axial movement of piston **230c** is likewise utilized drive radial rotation of cam **218b**. In this regard, the second roller **289** of cam follower assembly **226b** may be of a larger diameter than the second roller **287** of the other cam followers, since both rollers **286**, **289** of cam follower assembly **226b** are used to transfer load to cam **218b**. Thus, rollers **286** may be larger in diameter than rollers **287** in order to transfer load. Additionally, cam

**218b** may have an inwardly facing track **142** and an outwardly facing track **144** that are shaped the same as the corresponding track inwardly facing track of cam **218a** and **218c**.

Engine assembly **10** includes at least two piston series **202** symmetrically spaced about driveshaft axis **14**, such as piston series **202a** and **202b**. In one or more embodiments, engine assembly **10** includes at least three symmetrically spaced piston series **202**, while in other embodiments, engine assembly **10** includes at least four symmetrically spaced piston series **202**.

Moreover, while two serially aligned combustion chamber assemblies **224** with three corresponding cams **18** have been described, the disclosure is not limited in this regard. Thus, in other embodiments three or more combustion chamber assemblies **224** may be axially aligned in series along cylinder axis **25**, with a cam **18** disposed between each adjacent combustion chamber assemblies **224**, as well as a cam **18** disposed at opposing ends of the series of combustion chamber assemblies **224**.

Turning to FIG. **14a**, an alternative embodiment of engine assembly **10** (of FIG. **1**) is illustrated as engine **400**, wherein two or more piston pairs **402**, such as piston pairs **402a**, **402b**, are positioned to be parallel with driveshaft **12** but at different diameters about driveshaft **12**, and as such, utilize two or more cam pairs of different diameters mounted on driveshaft **12**. As shown, driveshaft **12** extends along a driveshaft axis **14**. Mounted along driveshaft **12** between driveshaft ends **412** and **413**, in spaced apart relationship to one another, are at least four harmonic barrel cams **418a**, **418b**, **418c** and **418d**, such as the barrel cams **18** described above, with barrel cams **418a**, **418b** forming a first set of cams and barrel cams **418c**, **418d** forming a second set of barrel cams. The cams **18** of each set oppose one another as generally described above. However, cams **18a**, **18b** of the first cam set have a first cam set diameter D1 (defined as  $R1*2$ ) while cams **18c**, **18d** of the second cam set have a second cam set diameter D2 (defined as  $R2*2$ ) that is greater than the first cam set diameter D1.

In some embodiments, piston pairs **402a**, **402b** may have the same angular position about driveshaft **12** so as to be generally adjacent one another, but radially spaced apart from one another in the same plane extending radially from driveshaft **12**, while in other embodiments, piston pairs **402a**, **402b** may have different angular position about driveshaft **12**.

More specifically, piston pair **402a** is comprised of a first piston assembly **422a** and a second piston assembly **422b** which piston assemblies **422a**, **422b** are axially aligned with one another within a cylinder assembly **424a** disposed along a cylinder axis **25a**. Combustion cylinder assembly **424a** is formed of a combustion cylinder **460a** extending between a first end **462a** and a second end **464a**. Cylinder axis **25a** is spaced apart from, but generally parallel with, driveshaft axis **14** of driveshaft **12**. Piston assembly **422a** includes a cam follower assembly **426a** attached to a piston arm **428a** to which is mounted a piston **430a**. Likewise, opposing piston assembly **422b** includes a cam follower assembly **426b** attached to a piston arm **428b** to which is mounted a piston **430b**. The opposed pistons **430a**, **430b** of piston pair **402a** are adapted to reciprocate in opposite directions along cylinder axis **25a**. Each cam follower assembly **426a**, **426b** includes a first roller **486** and a second roller **487**, straddles its respective cam **418a**, **418b** so as to be engaged by rollers **486**, **487** and acts on its respective piston **430a**, **430b**. Opposed pistons **430a**, **430b** within cylinder assembly **424a**

generally define a combustion chamber **432a** therebetween into which fuel may be injected.

Piston pair **402b** likewise is comprised of a first piston assembly **422c** and a second piston assembly **422d** which piston assemblies **422c**, **422d** are axially aligned with one another within a cylinder assembly **424b** disposed along a cylinder axis **25b**. Combustion cylinder assembly **424b** is formed of a combustion cylinder **460b** extending between a first end **462c** and a second end **464d**. Cylinder axis **25b** is spaced radially outward from, but generally parallel with cylinder axis **25a** of piston pair **402a**. Piston assembly **422c** includes a cam follower assembly **426c** attached to a piston arm **428c** to which is mounted a piston **430c**. Likewise, opposing piston assembly **422d** includes a cam follower assembly **426d** attached to a piston arm **428d** to which is mounted a piston **430d**. The opposed pistons **430c**, **430d** of piston pair **402b** are adapted to reciprocate in opposite directions along cylinder axis **25b**. Each cam follower assembly **426c**, **426d** straddles its respective cam **418c**, **418d** and acts on its respective piston **430c**, **430d**. Opposed pistons **430c**, **430d** within cylinder assembly **424b** generally define a combustion chamber **432b** therebetween into which fuel may be injected.

Each cam follower assembly **226a**, **226b**, **226c** and **226d** straddles its respective cam **218a**, **218b**, **218c**, **218d** and is movable with respect to its respective cam **218a**, **218b**, **218c**, **218d** so that axial movement of pistons **230a**, **230b**, **230c** and **230d** can be translated into radial rotation of the respective cams **218a**, **218b**, **218c**, **218d** so as to rotate driveshaft **12**.

In one or more embodiments, each cam **18** further includes a circumferential shoulder **438** extending around the cylindrical periphery of a cam hub **436**. Shoulder **438** is generally curvilinear in shape and can be characterized as having a certain frequency, where the frequency may generally refer to the number of occurrences of repeating peaks and troughs about the 360 degree circumference of the circumferential shoulder **438**. In some embodiments, the curvilinear shape of shoulders **438** of the first cam **418a** and second cam **418b** are of a first frequency and the curvilinear shape of shoulders **438** of the third cam **418c** and fourth cam **418d** are of a second frequency, which in some embodiments may differ from the first frequency. In some embodiments, it may be desirable for piston pairs **402a**, **402b** to translate in unison. In such case, the second frequency is less than the first frequency. In other embodiments, it may be desirable for piston pair **402b** to translate more rapidly than piston pair **402a**, in which case, the second frequency may be equal to or greater than the first frequency.

Similarly, in one or more embodiments, the amplitude of the curvilinear shoulders **438** of each cam **18a**, **18b**, **18c**, **18d** are the same, with the depth of the troughs and the height of the peaks being substantially equal, while in other embodiments, the depth of the troughs may differ from height of the peaks. In some embodiments, the amplitude of the third and fourth cams **18c**, **18d**, respectively is less than the amplitude of the first and second cams **18a**, **18b** in order to adjust timing of the respective piston pairs **402a**, **402b**. Because cams **18a**, **18b** of the first cam set have a different diameter **D1** than the diameter **D2** of cams **18c**, **18d**, shoulders **438** of the respective cams **18** are at different diameters. As such, piston pairs **402a**, **402b** may have the same angular position about driveshaft **12** so as to be generally adjacent one another, but radially spaced apart from one another in the same plane extending radially from driveshaft **12**.

While only two sets of cam pairs are illustrated, any number of sets of cam pairs may be utilized, each set with

a different diameter, thereby allowing the density of piston pairs **402** about driveshaft **12** to be increased. It will be appreciated that the greater number of piston pairs about driveshaft **12**, the more torque that can be generated by engine **10**. Thus, the foregoing arrangement allows greater engine power than would a barrel engine with piston pairs disposed at only one diameter about driveshaft **12**. Turning to FIG. **14b**, is an alternative embodiment of engine assembly engine **400** with two or more piston pairs **402**, such as piston pairs **402a**, **402b**, aligned in parallel about driveshaft **12**. In the embodiment of FIG. **14b**, rather than utilizing cam pairs of different diameters, a single cam pair **418a**, **418b** is utilized, but an interconnecting link **417** connects adjacent piston assemblies **422** so that the adjacent piston assemblies reciprocate in unison. Specifically, driveshaft **12** extends along a driveshaft axis **14**. Mounted along driveshaft **12** between driveshaft ends **412** and **413**, in spaced apart relationship to one another, are two harmonic barrel cams **418a**, **418b**, such as the barrel cams **18** described above. Cams **18a**, **18b** oppose one another as generally described above.

Piston pair **402a** is comprised of a first piston assembly **422a** and a second piston assembly **422b** which piston assemblies **422a**, **422b** are axially aligned with one another within a cylinder assembly **424a** disposed along a cylinder axis **25a**. Combustion cylinder assembly **424a** is formed of a combustion cylinder **460a** extending between a first end **462a** and a second end **464a**. Cylinder axis **25a** is spaced apart from, but generally parallel with, driveshaft axis **14** of driveshaft **12**. Piston assembly **422a** includes a cam follower assembly **426a** attached to a piston arm **428a** to which is mounted a piston **430a**. Likewise, opposing piston assembly **422b** includes a cam follower assembly **426b** attached to a piston arm **428b** to which is mounted a piston **430b**. The opposed pistons **430a**, **430b** of piston pair **402a** are adapted to reciprocate in opposite directions along cylinder axis **25a**. Each cam follower assembly **426a**, **426b** straddles its respective cam **418a**, **418b** and acts on its respective piston **430a**, **430b**. Opposed pistons **430a**, **430b** within cylinder assembly **424a** generally define a combustion chamber **432a** therebetween into which fuel may be injected.

Piston pair **402b** likewise is comprised of a first piston assembly **422c** and a second piston assembly **422d** which piston assemblies **422c**, **422d** are axially aligned with one another within a cylinder assembly **424b** disposed along a cylinder axis **25b**. Combustion cylinder assembly **424b** is formed of a combustion cylinder **460b** extending between a first end **462c** and a second end **464d**. Cylinder axis **25b** is spaced radially outward from, but generally parallel with cylinder axis **25a** of piston pair **402a**. Piston assembly **422c** includes a piston arm **428c** to which is mounted a piston **430c**. Likewise, opposing piston assembly **422d** includes a piston arm **428d** to which is mounted a piston **430d**. The opposed pistons **430c**, **430d** of piston pair **402b** are adapted to reciprocate in opposite directions along cylinder axis **25b**. Opposed pistons **430c**, **430d** within cylinder assembly **424b** generally define a combustion chamber **432b** therebetween into which fuel may be injected.

A link **417a** extends between adjacent piston assemblies **422a**, **422c**. Likewise, a link **417b** extends between adjacent piston assemblies **422b**, **422d**. Link **417** interconnects the respective adjacent piston assemblies **422** so that the assemblies will reciprocate in unison. Moreover, link **417** transfers axial force applied generated by the outer piston assembly **422** to inner piston assembly, and thus to the respective cam **18**. Link **417** may be any suitable structure for such interconnection, such as, for example, an arm, plate, rod, body or

similar structure. Moreover, link **417** can extend between any reciprocating portion of the piston assemblies **422**. In the illustrated embodiment, link **417** extends between a piston arm **428** and a cam follower assembly **226**, but in other embodiments, link **417** may interconnect other reciprocating components of piston assembly **422**. Thus, as shown, link **417a** interconnects cam follower assembly **226a** with piston arm **428c**, and link **417b** interconnects cam follower assembly **226b** with piston arm **428d**.

Each cam follower assembly **226a**, **226b** straddles its respective cam **218a**, **218b** and is movable with respect to its respective cam **218a**, **218b** so that axial movement of pistons **230a**, **230b**, **230c** and **230d** can be translated into radial rotation of the respective cams **218a**, **218b**, so as to rotate driveshaft **12**.

In other embodiments, cam follower assembly **226** is connected to two piston arms **428** and functions as the link **417** interconnecting the two adjacent piston assemblies **422**. In such embodiments, the cam **18** may have a radius that is between the two cylinder axes **25a**, **25b**, and cam follower assembly **226** may be positioned radially between adjacent piston arms **428**.

While FIG. **13** describes piston pairs **402** and combustion cylinder assemblies **424** in series, and FIGS. **14a** and **14b** describe piston pairs **402** and combustion cylinder assemblies **424** in parallel, it will be appreciated that in other embodiments of an engine assembly, piston pairs **402** and combustion cylinder assemblies **424** can be mounted in the engine assembly of the disclosure to be in both parallel and in series. Thus, in some embodiments of an engine assembly, two or more combustion cylinder assemblies **424** may be aligned in series along a first axis, such as axis **25a**, which first axis is parallel with and spaced apart from driveshaft axis **14**, with each of the two serially aligned combustion cylinder assemblies **424** having piston pairs **402** that are also generally aligned along the first axis **25a**. Likewise, two or more combustion cylinder assemblies **424** may be aligned in series along a second axis, such as axis **25b**, which second axis is parallel with and spaced apart from both driveshaft axis **14** and first axis **25a**, with each of the two serially aligned combustion cylinder assemblies **424** along second axis **25b** having piston pairs **402** that are also generally aligned along the second axis **25b**. For example, an embodiment of the foregoing engine may include first and second combustion cylinders serially or sequentially disposed along a first center cylindrical axis and third and fourth combustion cylinders serially or sequentially disposed along a second center cylindrical axis, where the first and second center cylindrical axes are parallel with one another, but the second center cylindrical axis is spaced radially outward from the first center cylindrical axis. In such an arrangement, it will be appreciated that the engine will have first, second, third, fourth, fifth, sixth, seventh and eighth piston assemblies mounted in the ends of the four combustion cylinders.

Turning to FIG. **15**, engine assembly **300** is illustrated, where one or more cams **318**, such as spaced apart cams **318a** and **318b**, are radially adjustable relative to driveshaft **312** utilizing a radial adjustment mechanism **304**. Specifically, in FIG. **15**, a simplified longitudinal section and cutaway view of an engine assembly **300** is shown, where driveshaft **312** extends along a primary axis **314** and passes axially through the center of the assembly **300**. Driveshaft **312** is supported by a pair of bearings **316a**, **316b** in a fixed axial position. Positioned along driveshaft **312** in spaced apart relationship to one another are harmonic barrel cams **318a**, **318b**. A piston pair **302a** comprises a first piston assembly **322a** and a second piston assembly **322b** which

piston assemblies **322a**, **322b** are axially aligned with one another within a cylinder assembly **324** disposed along a cylinder axis **325**. Cylinder axis **325** is spaced apart from but generally parallel with primary axis **314** of driveshaft **312**.

Each piston assembly **322** generally includes a cam follower assembly **326** attached to a piston arm **328** to which is mounted a piston **330**. The opposed pistons **330** of a piston pair **302a** are adapted to reciprocate in opposite directions along cylinder axis **325**. Each cam follower assembly **326** straddles its respective cam **318** and acts on piston **330** through piston arm **328**. Opposed pistons **330** within cylinder assembly **324** generally define a combustion chamber **332** therebetween into which fuel may be injected by a fuel injector **334**. Upon combustion of fuel within combustion chamber **332**, pistons **330** are driven away from one another along cylinder axis **325**, all as generally described above with respect to other embodiments. In the illustrated embodiment, engine assembly **300** further includes a second piston pair **302b** symmetrically positioned relative to piston pair **302a**.

Driveshaft **312** is further characterized by a first end **346** and a second end **348**. Axially formed in at least one end of driveshaft **312** is a first axially extending hydraulic passage **350** and a second axially extending hydraulic passage **352**, such as shown at first end **346**. In the illustrated embodiment, second end **348** likewise has a first axially extending hydraulic passage **354** and a second axially extending hydraulic passage **356**. A first radial passage **358** in fluid communication with the first hydraulic passage **350** is formed in driveshaft **312** and terminates at an outlet **360**. Likewise, a second radial passage **362** in fluid communication with the second hydraulic passage **352** is formed in driveshaft **312** and terminates at an outlet **364**.

Formed along driveshaft **312** is first collar **366** and second collar **368**, each extending radially outward from driveshaft **312**. In one embodiment, collars **366**, **368** are spaced apart from one another along driveshaft **312**. Collars **366**, **368** may be integrally formed as part of driveshaft **312** or separately formed.

Cam **318** is mounted on driveshaft **312** adjacent outlets **360**, **364** and collars **366**, **368**. In particular, cam **318** includes a hub **336** having a first end **337** mounted relative to first collar **366** so as to form a first pressure chamber **370** therebetween, with outlet **360** in fluid communication with first pressure chamber **370**. Likewise, hub **336** has a second end **339** mounted relative to second collar **368** so as to form a second pressure chamber **372** therebetween, with outlet **364** in fluid communication with second pressure chamber **372**.

Radial adjustment mechanism **304** may include a hydraulic fluid source **313a** in fluid communication with each of hydraulic passage **350** and hydraulic passage **352** to alternatively supply pressurized fluid (not shown) to one or the other of first pressure chamber **370** or second pressure chamber **372**. In this regard, radial adjustment mechanism **304** may further include a controller **309** to control delivery of fluid from fluid source **313** to the pressure chambers **370**, **372**. In this regard, controller **309** may receive data from one or more sensors **311** about a condition of the engine **300**, such as the rotational speed of cam **318** (sensor **311a**) or type of fuel being injected by fuel injector **334** (sensor **311b**) or the condition of the combustion gas existing cylinder assembly **324** (sensor **311c**), and control delivery of fluid from fluid source **313** in order to optimize the position of cam **318** relative to driveshaft **312** for a particular purpose. For example, it has been found that cam **318** may be in a first radial orientation relative to driveshaft **312** when a first type

of fuel, such as gasoline, is utilized in engine 300 and cam 318 may be in a second radial orientation (different than the first radial orientation) relative to driveshaft 312 when a second type of fuel, such as diesel, is utilized in engine 300. Persons of ordinary skill in the art will appreciate that application of a pressurized fluid to first pressure chamber 370 will result in radial rotation of cam 318 in a first direction relative to driveshaft 312 and application of a pressurized fluid (not shown) to second pressure chamber 372 will result in radial rotation of cam 318 in a second direction relative to driveshaft 312. Moreover, the relative pressures of the pressurized fluids in each of the chambers 370, 372 may be adjusted to adjust the radial orientation of cam 318 on driveshaft 12, as described above. It will also be appreciated that the foregoing is particularly desirable because changes to the relative position of cam 318 may be made dynamically in real time while engine 300 is in operation. These changes may be based on monitoring of various operational parameters and/or conditions of engine 300 with one or more sensors 315 in real time. Thus, in some embodiments, based on measurements from sensor 315, hydraulic fluid source 313 may be operated to rotate cam 318 in a first direction or a second direction relative to driveshaft 312 in order to achieve a desired output from a piston pair 302. Alternatively, the system may be static by maintaining the relative fluid pressure in each chamber at the same pressure.

Turning to FIGS. 16 and 17, cam 318 is shown with another embodiment of radial adjustment mechanism 304. Specifically, in this embodiment, driveshaft 312 includes a first lug 380 and second lug 382, each extending radially outward from driveshaft 312. In one embodiment, lugs 380, 382 opposed one another about driveshaft 312. Lugs 380, 382 may be integrally formed as part of driveshaft 312, as shown, or separately formed.

Driveshaft 312 further includes a first axially extending hydraulic passage 350 and a second axially extending hydraulic passage 352, preferably of varied axial lengths.

A first set of radial passages 384a, 384b is in fluid communication with the first axially extending hydraulic passage 350, each of the radial passages 384a, 384b formed in a lug 380, 382, respectively, and terminates at a ported lug outlet 385a, 385b. Likewise, a second set of radial passages 386a, 386b (shown in dashed), preferably spaced apart axially from the first set of radial passages 384a, 384b, is in fluid communication with the second axially extending hydraulic passage 352. Each of the radial passages 386a, 386b is formed in a lug 380, 382, respectively, and terminates at a ported lug outlet 387a, 387b.

Cam 318 is mounted on driveshaft 312 adjacent outlets 385, 387 and lugs 380, 382. In particular, cam 318 includes a hub 388 having a hub wall 389 with a curvilinear shoulder 390 extending radially outward from the outer circumference of hub wall 389. In some embodiments, as illustrated, shoulder 390 may be shaped to have two peaks with a corresponding number of troughs, such that the cam profiles describe two complete cycles per revolution and are thus double harmonics, while in other embodiments, shoulder 390 may have other number of peaks and troughs, as desired.

Formed along the inner circumference of hub wall 389 are first and second spaced apart slots 392a, 392b, each slot 392a, 392b disposed to receive a lug 380, 382, respectively. In one or more embodiments, the slots 392a, 392b may oppose one another. First slot 392a is characterized by a first shoulder 391a and a second shoulder 393a, while second slot 392b is characterized by a third shoulder 391b and a fourth shoulder 393b. In particular, lug 380 extends into first

slot 392a to form a first pressure chamber 394a between lug 380 and a first slot shoulder 391a, with outlet 385a in fluid communication with first pressure chamber 394a. Likewise, lug 382 extends into second slot 392b to form a third pressure chamber 394b between lug 382 and a third slot shoulder 391b, with outlet 385b in fluid communication with third pressure chamber 394b.

In one or more embodiments, such as the illustrated embodiments, a second pressure chamber 395a is formed between lug 380 and a second slot shoulder 393a, with outlet 387a in fluid communication with second pressure chamber 395a. Likewise, a fourth pressure chamber 395b is formed between lug 382 and a fourth slot shoulder 393b, with outlet 387b in fluid communication with fourth pressure chamber 395b.

It will be appreciated that in some embodiments, pressure chambers 394b and 395b, as well as passages 384b and 386b and ports 385b and 387b can be eliminated, with only a pressure chamber 394a utilized as a first pressure chamber to rotate cam 318 in a first direction relative to driveshaft 312, and only a pressure chamber 395a utilized as a second pressure chamber to rotate cam 318 in a second opposite direction relative to driveshaft 312.

Moreover, during operation of an engine, such as engine 300 employing the radial adjustment mechanism 304, pressurized fluid can be alternately supplied to chamber 394a or chamber 395a to dynamically adjust the radial position of cam 318 relative to driveshaft 312 as desired, rotating cam 318 either in a first clockwise direction or a second counterclockwise direction about driveshaft 312.

It will be appreciated that in each of the engine embodiments described herein, more work may be produced out of every increment of fuel with a shortened intake stroke combined with a full-length power stroke in longer displacements made by the counter opposed pistons arrangement in a central combustion chamber. Moreover, the engines experience very low vibration due to naturally balanced barrel architecture combined with balanced power pulse operating sequence described above. Variable compression ratio and phasing tune can be obtained through automatic or manual adjustment of the barrel cams relative to the driveshaft. Moreover, the closed circuit of forces during engine operations allows a much less robust and lighter casing for enveloping the engine. This also permits the use of a wide range of materials, such as plastics, cast and forged aluminum of the casing parts, block and other components. The closed circuit of forces comprises with the forces and stress induced by the power stroke expansion pressure applied on the piston head during the power stroke which flows from the piston head to the piston neck, to the piston rod, to the cam-rollers, to the cam and finally to the driveshaft so as to minimize applying moments and bending forces on the engine block, bearings and other parts as in a conventional engine fitted with a crankshaft and engine head.

The cylinders are fitted with intake and exhaust ports to operate the 2-stroke cycle, uniflow air intake and scavenging process. The phasing control is provided by the travelling time of the opposed-pistons, opening and closing the intake and exhaust ports, governed by cam design, that can accelerate or slowdown pistons travelling speeds, and its number of wave lengths.

Thus, an internal combustion engine has been described. The internal combustion engine may include a driveshaft having a first end and a second end and disposed along a driveshaft axis; a first cam mounted on the driveshaft, the first cam having a circumferential shoulder of a first cam diameter and a first curvilinear shape with a first frequency;

a second cam mounted on the driveshaft spaced apart from the first cam, the second cam having a circumferential shoulder of a second curvilinear shape which second curvilinear shape has the same frequency as the first curvilinear shape; a first combustion cylinder defined along a center cylinder axis, the combustion cylinder having a first end and a second end with an intake port formed in the cylinder between the first and second ends and an exhaust port formed in the cylinder between the intake port and the second end, the center cylinder axis being parallel with but spaced apart from the driveshaft axis, wherein a combustion chamber is defined within the cylinder between the two cylinder ends; a first piston assembly disposed in the first cylinder end of the first combustion cylinder and an opposing second piston assembly disposed in the second cylinder end of the first combustion cylinder, the first piston assembly engaging the curvilinear shaped shoulder of the first cam and the second piston assembly engaging the curvilinear shaped shoulder of the second cam, each piston assembly movable between an inner dead center position in which the piston assembly is fully extended in the combustion chamber away from its corresponding cam and an outer dead center position in which the piston assembly is fully retracted in the combustion chamber away from the inner dead center position; and at least one fuel injector disposed adjacent the center of the combustion cylinder and in communication with said combustion chamber. In other embodiments, the internal combustion engine may include a driveshaft having a first end and a second end and disposed along a driveshaft axis; a first cam mounted on the driveshaft, the first cam having a circumferential shoulder of a first cam diameter and a first curvilinear shape with a first frequency; a second cam mounted on the driveshaft spaced apart from the first cam, the second cam having a circumferential shoulder of a second curvilinear shape which second curvilinear shape has the same frequency as the first curvilinear shape; a first combustion cylinder defined along a center cylinder axis, the combustion cylinder having a first end and a second end with an intake port formed in the cylinder between the first and second ends and an exhaust port formed in the cylinder between the intake port and the second end, the center cylinder axis being parallel with but spaced apart from the driveshaft axis, wherein a combustion chamber is defined within the cylinder between the two cylinder ends; a first piston assembly disposed in the first cylinder end of the first combustion cylinder and an opposing second piston assembly disposed in the second cylinder end of the first combustion cylinder, the first piston assembly engaging the curvilinear shaped shoulder of the first cam and the second piston assembly engaging the curvilinear shaped shoulder of the second cam, each piston assembly movable between an inner dead center position in which the piston assembly is fully extended in the combustion chamber away from its corresponding cam and an outer dead center position in which the piston assembly is fully retracted in the combustion chamber away from the inner dead center position; at least one fuel injector disposed adjacent the center of the combustion cylinder and in communication with said combustion chamber; and a second combustion cylinder having a first end and a second end, the second combustion cylinder defined along the center cylinder axis so as to be axially aligned with the first combustion cylinder; a third piston assembly disposed in the first cylinder end of the second combustion cylinder; and an opposing fourth piston assembly disposed in the second cylinder end of the second combustion cylinder. In other embodiments, the internal combustion engine may include a driveshaft having a first

end and a second end and disposed along a driveshaft axis; a first cam mounted on the driveshaft, the first cam having a circumferential shoulder of a first cam diameter and a first curvilinear shape with a first frequency; a second cam mounted on the driveshaft spaced apart from the first cam, the second cam having a circumferential shoulder of a second curvilinear shape which second curvilinear shape has the same frequency as the first curvilinear shape; a first combustion cylinder defined along a center cylinder axis, the combustion cylinder having a first end and a second end with an intake port formed in the cylinder between the first and second ends and an exhaust port formed in the cylinder between the intake port and the second end, the center cylinder axis being parallel with but spaced apart from the driveshaft axis, wherein a combustion chamber is defined within the cylinder between the two cylinder ends; a first piston assembly disposed in the first cylinder end of the first combustion cylinder and an opposing second piston assembly disposed in the second cylinder end of the first combustion cylinder, the first piston assembly engaging the curvilinear shaped shoulder of the first cam and the second piston assembly engaging the curvilinear shaped shoulder of the second cam, each piston assembly movable between an inner dead center position in which the piston assembly is fully extended in the combustion chamber away from its corresponding cam and an outer dead center position in which the piston assembly is fully retracted in the combustion chamber away from the inner dead center position; at least one fuel injector disposed adjacent the center of the combustion cylinder and in communication with said combustion chamber; and a second combustion cylinder defined along the center cylinder axis so as to be axially aligned with the first combustion cylinder, the second combustion cylinder having a first end and a second end with an intake port formed in the cylinder between the first and second ends and an exhaust port formed in the cylinder between the intake port and the second end, the center cylinder axis being parallel with but spaced apart from the driveshaft axis, wherein a combustion chamber is defined within the cylinder between the two cylinder ends with a piston assembly disposed in each second combustion cylinder end so that piston heads of the piston assemblies of the cylinder oppose one another within the cylinder. In other embodiments, the internal combustion engine may include a driveshaft having a first end and a second end and disposed along a driveshaft axis; a first cam mounted on the driveshaft, the first cam having a circumferential shoulder of a first cam diameter and a first curvilinear shape with a first frequency; a second cam mounted on the driveshaft spaced apart from the first cam, the second cam having a circumferential shoulder of a second curvilinear shape which second curvilinear shape has the same frequency as the first curvilinear shape; a first combustion cylinder defined along a center cylinder axis, the combustion cylinder having a first end and a second end with an intake port formed in the cylinder between the first and second ends and an exhaust port formed in the cylinder between the intake port and the second end, the center cylinder axis being parallel with but spaced apart from the driveshaft axis, wherein a combustion chamber is defined within the cylinder between the two cylinder ends; a first piston assembly disposed in the first cylinder end of the first combustion cylinder and an opposing second piston assembly disposed in the second cylinder end of the first combustion cylinder, the first piston assembly engaging the curvilinear shaped shoulder of the first cam and the second piston assembly engaging the curvilinear shaped shoulder of the second cam, each piston assembly movable between an

inner dead center position in which the piston assembly is fully extended in the combustion chamber away from its corresponding cam and an outer dead center position in which the piston assembly is fully retracted in the combustion chamber away from the inner dead center position; at least one fuel injector disposed adjacent the center of the combustion cylinder and in communication with said combustion chamber; wherein the combustion cylinder further comprises a cylinder wall and the exhaust port comprises a plurality of exhaust slots formed in the cylinder wall between the fuel injector and the second end, each exhaust slot extending along a slot axis generally parallel with the central cylinder axis, the intake port comprising a plurality of intake slots formed in the cylinder wall between the fuel injector and the first end, each intake slot extending along a slot axis generally diagonal with the central cylinder axis. In other embodiments, the internal combustion engine may include a driveshaft having a first end and a second end and disposed along a driveshaft axis; a first cam mounted on the driveshaft, the first cam having a circumferential shoulder of a first cam diameter and a first curvilinear shape with a first frequency; a second cam mounted on the driveshaft spaced apart from the first cam, the second cam having a circumferential shoulder of a second curvilinear shape which second curvilinear shape has the same frequency as the first curvilinear shape; a first combustion cylinder defined along a center cylinder axis, the combustion cylinder having a first end and a second end with an intake port formed in the cylinder between the first and second ends and an exhaust port formed in the cylinder between the intake port and the second end, the center cylinder axis being parallel with but spaced apart from the driveshaft axis, wherein a combustion chamber is defined within the cylinder between the two cylinder ends; a first piston assembly disposed in the first cylinder end of the first combustion cylinder and an opposing second piston assembly disposed in the second cylinder end of the first combustion cylinder, the first piston assembly engaging the curvilinear shaped shoulder of the first cam and the second piston assembly engaging the curvilinear shaped shoulder of the second cam, each piston assembly movable between an inner dead center position in which the piston assembly is fully extended in the combustion chamber away from its corresponding cam and an outer dead center position in which the piston assembly is fully retracted in the combustion chamber away from the inner dead center position; at least one fuel injector disposed adjacent the center of the combustion cylinder and in communication with said combustion chamber; and at least one annular flow manifold extending at least partially around the driveshaft, the annular flow manifold fluidically connecting the ports of two or more combustion cylinders. In other embodiments, the internal combustion engine may include a driveshaft having a first end and a second end and disposed along a driveshaft axis; a first cam mounted on the driveshaft, the first cam having a circumferential shoulder of a first cam diameter and a first curvilinear shape with a first frequency; a second cam mounted on the driveshaft spaced apart from the first cam, the second cam having a circumferential shoulder of a second curvilinear shape which second curvilinear shape has the same frequency as the first curvilinear shape; a first combustion cylinder defined along a center cylinder axis, the combustion cylinder having a first end and a second end with an intake port formed in the cylinder between the first and second ends and an exhaust port formed in the cylinder between the intake port and the second end, the center cylinder axis being parallel with but spaced apart from the driveshaft axis, wherein a combustion chamber is defined

within the cylinder between the two cylinder ends; a first piston assembly disposed in the first cylinder end of the first combustion cylinder and an opposing second piston assembly disposed in the second cylinder end of the first combustion cylinder, the first piston assembly engaging the curvilinear shaped shoulder of the first cam and the second piston assembly engaging the curvilinear shaped shoulder of the second cam, each piston assembly movable between an inner dead center position in which the piston assembly is fully extended in the combustion chamber away from its corresponding cam and an outer dead center position in which the piston assembly is fully retracted in the combustion chamber away from the inner dead center position; at least one fuel injector disposed adjacent the center of the combustion cylinder and in communication with said combustion chamber; and an annular intake manifold extending at least partially around the driveshaft and fluidically connecting the intake ports of two or more combustion cylinders; and an annular exhaust manifold extending at least partially around the driveshaft, spaced axially apart from the annular intake manifold, the annular exhaust manifold fluidically connecting the exhaust ports of two or more combustion cylinders. In other embodiments, the internal combustion engine may include a driveshaft having a first end and a second end and disposed along a driveshaft axis; a first cam mounted on the driveshaft, the first cam having a circumferential shoulder of a first cam diameter and a first curvilinear shape with a first frequency; a second cam mounted on the driveshaft spaced apart from the first cam, the second cam having a circumferential shoulder of a second curvilinear shape which second curvilinear shape has the same frequency as the first curvilinear shape; a first combustion cylinder defined along a center cylinder axis, the combustion cylinder having a first end and a second end with an intake port formed in the cylinder between the first and second ends and an exhaust port formed in the cylinder between the intake port and the second end, the center cylinder axis being parallel with but spaced apart from the driveshaft axis, wherein a combustion chamber is defined within the cylinder between the two cylinder ends; a first piston assembly disposed in the first cylinder end of the first combustion cylinder and an opposing second piston assembly disposed in the second cylinder end of the first combustion cylinder, the first piston assembly engaging the curvilinear shaped shoulder of the first cam and the second piston assembly engaging the curvilinear shaped shoulder of the second cam, each piston assembly movable between an inner dead center position in which the piston assembly is fully extended in the combustion chamber away from its corresponding cam and an outer dead center position in which the piston assembly is fully retracted in the combustion chamber away from the inner dead center position; at least one fuel injector disposed adjacent the center of the combustion cylinder and in communication with said combustion chamber; and an engine block in which the driveshaft and combustion cylinder are supported, the engine block extends between a first end and a second end and includes an annular body portion therebetween, which annular body portion is characterized by an exterior surface and in which is formed a first annular channel and a second annular channel spaced apart from one another, the first annular channel in fluid communication with the intake port of the combustion cylinder and the second annular channel in fluid communication with the exhaust port of the combustion cylinder. In other embodiments, the internal combustion engine may include a driveshaft having a first end and a second end and disposed along a driveshaft axis; a first

cam mounted on the driveshaft, the first cam having a circumferential shoulder of a first cam diameter and a first curvilinear shape with a first frequency; a second cam mounted on the driveshaft spaced apart from the first cam, the second cam having a circumferential shoulder of a second curvilinear shape which second curvilinear shape has the same frequency as the first curvilinear shape; a first combustion cylinder defined along a center cylinder axis, the combustion cylinder having a first end and a second end with an intake port formed in the cylinder between the first and second ends and an exhaust port formed in the cylinder between the intake port and the second end, the center cylinder axis being parallel with but spaced apart from the driveshaft axis, wherein a combustion chamber is defined within the cylinder between the two cylinder ends; a first piston assembly disposed in the first cylinder end of the first combustion cylinder and an opposing second piston assembly disposed in the second cylinder end of the first combustion cylinder, the first piston assembly engaging the curvilinear shaped shoulder of the first cam and the second piston assembly engaging the curvilinear shaped shoulder of the second cam, each piston assembly movable between an inner dead center position in which the piston assembly is fully extended in the combustion chamber away from its corresponding cam and an outer dead center position in which the piston assembly is fully retracted in the combustion chamber away from the inner dead center position; and at least one fuel injector disposed adjacent the center of the combustion cylinder and in communication with said combustion chamber; wherein the first cam comprises a hub mounted on driveshaft with the circumferential shoulder extending around a periphery of hub, the curvilinear shaped first cam shoulder has at least two peaks and at least two troughs formed by the shoulder, wherein each trough includes a substantially flat portion at its base and wherein each peak is rounded at its apex; the second cam comprises a hub mounted on driveshaft with the circumferential shoulder extending around a periphery of hub, the curvilinear shaped second cam shoulder has at least two crests and at least two troughs formed by the shoulder and corresponding in number to the crests and troughs of the first cam, wherein each trough of the second cam is rounded at its base and wherein each peak includes a substantially flat portion at its apex. In other embodiments, the internal combustion engine may include a driveshaft having a first end and a second end and disposed along a driveshaft axis; a first cam mounted on the driveshaft, the first cam having a circumferential shoulder of a first cam diameter and a first curvilinear shape with a first frequency; a second cam mounted on the driveshaft spaced apart from the first cam, the second cam having a circumferential shoulder of a second curvilinear shape which second curvilinear shape has the same frequency as the first curvilinear shape; a first combustion cylinder defined along a center cylinder axis, the combustion cylinder having a first end and a second end with an intake port formed in the cylinder between the first and second ends and an exhaust port formed in the cylinder between the intake port and the second end, the center cylinder axis being parallel with but spaced apart from the driveshaft axis, wherein a combustion chamber is defined within the cylinder between the two cylinder ends; a first piston assembly disposed in the first cylinder end of the first combustion cylinder and an opposing second piston assembly disposed in the second cylinder end of the first combustion cylinder, the first piston assembly engaging the curvilinear shaped shoulder of the first cam and the second piston assembly engaging the curvilinear shaped shoulder of the second cam,

each piston assembly movable between an inner dead center position in which the piston assembly is fully extended in the combustion chamber away from its corresponding cam and an outer dead center position in which the piston assembly is fully retracted in the combustion chamber away from the inner dead center position; and at least one fuel injector disposed adjacent the center of the combustion cylinder and in communication with said combustion chamber; wherein the first cam comprises a hub mounted on driveshaft with the circumferential shoulder extending around a periphery of hub, the curvilinear shaped first cam shoulder has at least two peaks having a first peak amplitude and at least two troughs having a first trough amplitude, wherein the first trough amplitude is less than the first peak amplitude; and the second cam comprises a hub mounted on driveshaft with the circumferential shoulder extending around a periphery of hub, the curvilinear shaped second cam shoulder has at least two peaks having a second peak amplitude and at least two troughs having a second trough amplitude, wherein the second trough amplitude is greater than the second peak amplitude. In other embodiments, the internal combustion engine may include a driveshaft having a first end and a second end and disposed along a driveshaft axis; a first cam mounted on the driveshaft, the first cam having a circumferential shoulder of a first cam diameter and a first curvilinear shape with a first frequency; a second cam mounted on the driveshaft spaced apart from the first cam, the second cam having a circumferential shoulder of a second curvilinear shape which second curvilinear shape has the same frequency as the first curvilinear shape; a first combustion cylinder defined along a center cylinder axis, the combustion cylinder having a first end and a second end with an intake port formed in the cylinder between the first and second ends and an exhaust port formed in the cylinder between the intake port and the second end, the center cylinder axis being parallel with but spaced apart from the driveshaft axis, wherein a combustion chamber is defined within the cylinder between the two cylinder ends; a first piston assembly disposed in the first cylinder end of the first combustion cylinder and an opposing second piston assembly disposed in the second cylinder end of the first combustion cylinder, the first piston assembly engaging the curvilinear shaped shoulder of the first cam and the second piston assembly engaging the curvilinear shaped shoulder of the second cam, each piston assembly movable between an inner dead center position in which the piston assembly is fully extended in the combustion chamber away from its corresponding cam and an outer dead center position in which the piston assembly is fully retracted in the combustion chamber away from the inner dead center position; and at least one fuel injector disposed adjacent the center of the combustion cylinder and in communication with said combustion chamber; wherein the piston assembly comprises a piston arm having a first annular body of a piston arm diameter spaced apart from a second annular body having a similar piston arm diameter and interconnected by a smaller diameter neck, with a piston attached to the first annular body and a cam follower attached to the second annular body. In other embodiments, the internal combustion engine may include a driveshaft having a first end and a second end and disposed along a driveshaft axis; a first cam mounted on the driveshaft, the first cam having a circumferential shoulder of a first cam diameter and a first curvilinear shape with a first frequency; a second cam mounted on the driveshaft spaced apart from the first cam, the second cam having a circumferential shoulder of a second curvilinear shape which second curvilinear shape has the same frequency as the first curvilinear

shape; a first combustion cylinder defined along a center cylinder axis, the combustion cylinder having a first end and a second end with an intake port formed in the cylinder between the first and second ends and an exhaust port formed in the cylinder between the intake port and the second end, the center cylinder axis being parallel with but spaced apart from the driveshaft axis, wherein a combustion chamber is defined within the cylinder between the two cylinder ends; a first piston assembly disposed in the first cylinder end of the first combustion cylinder and an opposing second piston assembly disposed in the second cylinder end of the first combustion cylinder, the first piston assembly engaging the curvilinear shaped shoulder of the first cam and the second piston assembly engaging the curvilinear shaped shoulder of the second cam, each piston assembly movable between an inner dead center position in which the piston assembly is fully extended in the combustion chamber away from its corresponding cam and an outer dead center position in which the piston assembly is fully retracted in the combustion chamber away from the inner dead center position; at least one fuel injector disposed adjacent the center of the combustion cylinder and in communication with said combustion chamber; wherein the piston assembly comprises a piston arm having a first end and a second end, with a piston attached to the first end of the piston arm and a cam follower attached to the second end of the piston arm, wherein the cam follower assembly includes an elongated body having a first end and a second end, wherein the elongated body is generally cylindrically shaped at each end, which ends are interconnected by an arm within which is formed a lubrication passage extending along a portion of the length of the arm between the two ends, the elongated body having an axially extending first slot in formed in the body adjacent the first end and an axially extending second slot formed in the body adjacent the second; a first roller mounted to the body in the first slot; and a second roller mounted to the body in the second slot, wherein the lubrication passage extends in the arm between the two rollers. In other embodiments, the internal combustion engine may include a driveshaft having a first end and a second end and disposed along a driveshaft axis; a first cam mounted on the driveshaft, the first cam having a circumferential shoulder of a first cam diameter and a first curvilinear shape with a first frequency; a second cam mounted on the driveshaft spaced apart from the first cam, the second cam having a circumferential shoulder of a second curvilinear shape which second curvilinear shape has the same frequency as the first curvilinear shape; a first combustion cylinder defined along a center cylinder axis, the combustion cylinder having a first end and a second end with an intake port formed in the cylinder between the first and second ends and an exhaust port formed in the cylinder between the intake port and the second end, the center cylinder axis being parallel with but spaced apart from the driveshaft axis, wherein a combustion chamber is defined within the cylinder between the two cylinder ends; a first piston assembly disposed in the first cylinder end of the first combustion cylinder and an opposing second piston assembly disposed in the second cylinder end of the first combustion cylinder, the first piston assembly engaging the curvilinear shaped shoulder of the first cam and the second piston assembly engaging the curvilinear shaped shoulder of the second cam, each piston assembly movable between an inner dead center position in which the piston assembly is fully extended in the combustion chamber away from its corresponding cam and an outer dead center position in which the piston assembly is fully retracted in the combustion chamber away from the inner dead center posi-

tion; at least one fuel injector disposed adjacent the center of the combustion cylinder and in communication with said combustion chamber; and a first guidance cap positioned adjacent the first end of the driveshaft and a second guidance cap positioned adjacent the second end of the driveshaft, wherein each guidance cap is coaxially mounted around a driveshaft end, outwardly of the cam between the cam and the driveshaft end, wherein the guidance cap comprises a central bore through which the driveshaft extends and two or more symmetrically positioned follower bores radially spaced outward of central bore with each follower bore slidably receiving the cylindrically shaped second end of a cam follower assembly. In other embodiments, the internal combustion engine may include a driveshaft having a first end and a second end and disposed along a driveshaft axis; a first cam mounted on the driveshaft, the first cam having a circumferential shoulder of a first cam diameter and a first curvilinear shape with a first frequency; a second cam mounted on the driveshaft spaced apart from the first cam, the second cam having a circumferential shoulder of a second curvilinear shape which second curvilinear shape has the same frequency as the first curvilinear shape; a first combustion cylinder defined along a center cylinder axis, the combustion cylinder having a first end and a second end with an intake port formed in the cylinder between the first and second ends and an exhaust port formed in the cylinder between the intake port and the second end, the center cylinder axis being parallel with but spaced apart from the driveshaft axis, wherein a combustion chamber is defined within the cylinder between the two cylinder ends; a first piston assembly disposed in the first cylinder end of the first combustion cylinder and an opposing second piston assembly disposed in the second cylinder end of the first combustion cylinder, the first piston assembly engaging the curvilinear shaped shoulder of the first cam and the second piston assembly engaging the curvilinear shaped shoulder of the second cam, each piston assembly movable between an inner dead center position in which the piston assembly is fully extended in the combustion chamber away from its corresponding cam and an outer dead center position in which the piston assembly is fully retracted in the combustion chamber away from the inner dead center position; and at least one fuel injector disposed adjacent the center of the combustion cylinder and in communication with said combustion chamber; wherein the piston assembly comprises a piston arm having a first end and a second end, with a piston attached to the first end of the piston arm and a cam follower attached to the second end of the piston arm, wherein the piston is formed of an annular body having a first end attached to piston arm and a second end, with a crown formed at the second end of the annular body, the crown having an indentation formed in an outwardly facing crown surface. In other embodiments, the internal combustion engine may include a driveshaft having a first end and a second end and disposed along a driveshaft axis; a first cam mounted on the driveshaft, the first cam having a circumferential shoulder of a first cam diameter and a first curvilinear shape with a first frequency; a second cam mounted on the driveshaft spaced apart from the first cam, the second cam having a circumferential shoulder of a second curvilinear shape which second curvilinear shape has the same frequency as the first curvilinear shape; a first combustion cylinder defined along a center cylinder axis, the combustion cylinder having a first end and a second end with an intake port formed in the cylinder between the first and second ends and an exhaust port formed in the cylinder between the intake port and the second end, the center cylinder axis being

35

parallel with but spaced apart from the driveshaft axis, wherein a combustion chamber is defined within the cylinder between the two cylinder ends; a first piston assembly disposed in the first cylinder end of the first combustion cylinder and an opposing second piston assembly disposed in the second cylinder end of the first combustion cylinder, the first piston assembly engaging the curvilinear shaped shoulder of the first cam and the second piston assembly engaging the curvilinear shaped shoulder of the second cam, each piston assembly movable between an inner dead center position in which the piston assembly is fully extended in the combustion chamber away from its corresponding cam and an outer dead center position in which the piston assembly is fully retracted in the combustion chamber away from the inner dead center position; at least one fuel injector disposed adjacent the center of the combustion cylinder and in communication with said combustion chamber; a second combustion cylinder having a first end and a second end and defined along second center cylinder axis parallel with the first combustion cylinder central axis but radially spaced outward from the first combustion cylinder central axis; a third cam mounted on the driveshaft between the first cam and the first driveshaft end, the third cam having a circumferential shoulder of a third cam diameter and a third curvilinear shape with a third frequency, the third cam diameter being larger than the first cam diameter; and a fourth cam mounted on the driveshaft between the second cam and the second end of the driveshaft, the fourth cam having a circumferential shoulder of a fourth curvilinear shape which fourth curvilinear shape has the same frequency as the third curvilinear shape. In yet other embodiments, the internal combustion engine may include a driveshaft having a first end and a second end and disposed along a driveshaft axis; a first cam mounted on the driveshaft, the first cam having a circumferential shoulder of a first cam diameter and a first curvilinear shape with a first frequency; a second cam mounted on the driveshaft spaced apart from the first cam, the second cam having a circumferential shoulder of a second curvilinear shape which second curvilinear shape has the same frequency as the first curvilinear shape; a first combustion cylinder defined along a center cylinder axis, the combustion cylinder having a first end and a second end with an intake port formed in the cylinder between the first and second ends and an exhaust port formed in the cylinder between the intake port and the second end, the center cylinder axis being parallel with but spaced apart from the driveshaft axis, wherein a combustion chamber is defined within the cylinder between the two cylinder ends; a first piston assembly disposed in the first cylinder end of the first combustion cylinder and an opposing second piston assembly disposed in the second cylinder end of the first combustion cylinder, the first piston assembly engaging the curvilinear shaped shoulder of the first cam and the second piston assembly engaging the curvilinear shaped shoulder of the second cam, each piston assembly movable between an inner dead center position in which the piston assembly is fully extended in the combustion chamber away from its corresponding cam and an outer dead center position in which the piston assembly is fully retracted in the combustion chamber away from the inner dead center position; a second combustion cylinder having a first end and a second end, the second combustion cylinder defined along the center cylinder axis so as to be axially aligned with the first combustion cylinder; a third piston assembly disposed in the first cylinder end of the second combustion cylinder; and an opposing fourth piston assembly disposed in the second cylinder end of the second combustion cylinder; a third

36

combustion cylinder having a first end and a second end and defined along second center cylinder axis parallel with the first combustion cylinder central axis but radially spaced outward from the first combustion cylinder central axis; a fifth piston assembly disposed in the first cylinder end of the third combustion cylinder; and an opposing sixth piston assembly disposed in the second cylinder end of the third combustion cylinder; a fourth combustion cylinder having a first end and a second end, the fourth combustion cylinder defined along the second center cylinder axis so as to be axially aligned with the third combustion cylinder; a seventh piston assembly disposed in the first cylinder end of the fourth combustion cylinder; and an opposing eighth piston assembly disposed in the second cylinder end of the fourth combustion cylinder; and at least one fuel injector disposed adjacent the center of each combustion cylinder and in communication with said combustion chamber of its respective combustion cylinder. In yet other embodiments, the internal combustion engine may include a driveshaft having a first end and a second end and disposed along a driveshaft axis; a first cam mounted on the driveshaft, the first cam having a circumferential shoulder of a first cam diameter and a first curvilinear shape with a first frequency; a second cam mounted on the driveshaft spaced apart from the first cam, the second cam having a circumferential shoulder of a second curvilinear shape which second curvilinear shape has the same frequency as the first curvilinear shape; a first combustion cylinder defined along a center cylinder axis, the combustion cylinder having a first end and a second end with an intake port formed in the cylinder between the first and second ends and an exhaust port formed in the cylinder between the intake port and the second end, the center cylinder axis being parallel with but spaced apart from the driveshaft axis, wherein a combustion chamber is defined within the first combustion cylinder between the two cylinder ends; a first piston assembly disposed in the first cylinder end of the first combustion cylinder and an opposing second piston assembly disposed in the second cylinder end of the first combustion cylinder, the first piston assembly engaging the curvilinear shaped shoulder of the first cam and the second piston assembly engaging the curvilinear shaped shoulder of the second cam, each piston assembly movable between an inner dead center position in which the piston assembly is fully extended in the combustion chamber away from its corresponding cam and an outer dead center position in which the piston assembly is fully retracted in the combustion chamber away from the inner dead center position; a second combustion cylinder having a first end and a second end and defined along second center cylinder axis parallel with the first combustion cylinder central axis but radially spaced outward from the first combustion cylinder central axis, wherein a combustion chamber is defined within the second combustion cylinder between the two cylinder ends; a third piston assembly disposed in the first cylinder end of the second combustion cylinder and an opposing fourth piston assembly disposed in the second cylinder end of the second combustion cylinder; and at least one fuel injector disposed adjacent the center of each combustion cylinder and in communication with the respective combustion chamber. In yet other embodiments, the internal combustion engine may include a driveshaft having a first end and a second end and disposed along a driveshaft axis; a first cam mounted on the driveshaft, the first cam having a circumferential shoulder of a first cam diameter and a first curvilinear shape with a first frequency; a second cam mounted on the driveshaft spaced apart from the first cam, the second cam having a circumferential shoulder of a

second curvilinear shape which second curvilinear shape has the same frequency as the first curvilinear shape; a first combustion cylinder defined along a center cylinder axis, the combustion cylinder having a first end and a second end with an intake port formed in the cylinder between the first and second ends and an exhaust port formed in the cylinder between the intake port and the second end, the center cylinder axis being parallel with but spaced apart from the driveshaft axis, wherein a combustion chamber is defined within the first combustion cylinder between the two cylinder ends; a first piston assembly disposed in the first cylinder end of the first combustion cylinder and an opposing second piston assembly disposed in the second cylinder end of the first combustion cylinder, each piston assembly movable between an inner dead center position in which the piston assembly is fully extended in the combustion chamber away from its corresponding cam and an outer dead center position in which the piston assembly is fully retracted in the combustion chamber away from the inner dead center position; a second combustion cylinder having a first end and a second end and defined along second center cylinder axis parallel with the first combustion cylinder central axis but radially spaced outward from the first combustion cylinder central axis, wherein a combustion chamber is defined within the second combustion cylinder between the two cylinder ends; a third piston assembly disposed in the first cylinder end of the second combustion cylinder and an opposing fourth piston assembly disposed in the second cylinder end of the second combustion cylinder; and at least one fuel injector disposed adjacent the center of each combustion cylinder and in communication with the respective combustion chamber. In other embodiments, the internal combustion engine includes a driveshaft having a first end and a second end and disposed along a driveshaft axis, with a first hydraulic passage extending from a driveshaft end to a first outlet and a second hydraulic passage extending from a driveshaft end to a second outlet spaced apart from the first outlet; a first piston disposed to reciprocate along a piston axis, the first piston axis being parallel with but spaced apart from the driveshaft axis; a first collar formed along the driveshaft adjacent the first outlet and a second collar formed along the driveshaft adjacent the second outlet, each collar extending radially outward from driveshaft; and a first cam rotatably mounted on the driveshaft adjacent the first and second collars, the first cam having a first hub having a first end mounted adjacent the first collar so as to form a first pressure chamber between the hub first end and the first collar, with the first outlet in fluid communication with the first pressure chamber, the hub having a second end mounted adjacent the second collar so as to form a second pressure chamber between the hub second end and the second collar, with the second outlet in fluid communication with second pressure chamber, with a circumferential cam shoulder extending around a periphery of the hub, the cam shoulder having a first cam diameter and a first polynomial shaped track. In other embodiments, the internal combustion engine includes a driveshaft having a first end and a second end and disposed along a driveshaft axis, with a first hydraulic passage extending from a driveshaft end and a second hydraulic passage extending from a driveshaft end, a first set of radial passages in fluid communication with the first hydraulic passage and a second set of radial passages in fluid communication with the second hydraulic passage; a first piston disposed to reciprocate along a piston axis, the first piston axis being parallel with but spaced apart from the driveshaft axis; a first cam rotatably mounted on the driveshaft, the first cam having a first hub with a circumferential

cam shoulder extending around a periphery of the first hub, the cam shoulder having a first cam diameter and a first polynomial shaped track; a first radially extending lug formed along the driveshaft adjacent the first cam hub and a second radially extending lug formed along the driveshaft adjacent the first cam hub, a radial passage of the first set of radial passages terminating in a first ported lug outlet formed in the first lug and a radial passage of the second set of radial passages terminating in a second ported lug outlet formed in the first lug, a radial passage of the first set of radial passages terminating in a third ported lug outlet formed in the second lug and a radial passage of the second set of radial passages terminating in a fourth ported lug outlet formed in the second lug; a first pressure chamber formed between the first lug and the first cam hub and a second pressure chamber, formed between the first lug and the first cam hub, the first ported lug outlet in the first lug in fluid communication with the first pressure chamber and the third ported lug outlet in the first lug in fluid communication with the second pressure chamber; a third pressure chamber formed between the second lug and the first cam hub; and a fourth pressure chamber formed between the second lug and the first cam hub, the second ported lug outlet in the second lug in fluid communication with the second pressure chamber and the fourth ported lug outlet in the second lug in fluid communication with the fourth pressure chamber. In other embodiments, the internal combustion engine includes a driveshaft having a first end and a second end and disposed along a driveshaft axis; a piston disposed to reciprocate along a piston axis, the piston axis being parallel with but spaced apart from the driveshaft axis, and a first cam mounted on the driveshaft, the first cam comprising a cam hub attached to the driveshaft, and a circumferential cam shoulder extending around a periphery of the hub, the cam shoulder having a first cam diameter and a first segmented polynomial shape, the shoulder having at least two lobes formed by the polynomial shape, each lobe characterized by a peak positioned between a first trough and a second trough and a lobe wavelength between the two troughs, the peak having a maximum amplitude for the lobe, where the wavelength distance from the first trough to peak along an ascending shoulder portion of the lobe is greater than the wavelength distance from the peak to the second trough along a descending shoulder portion of the lobe; and a second cam mounted on the driveshaft and spaced apart from the first cam, the second cam comprising a cam hub attached to the driveshaft, and a circumferential cam shoulder extending around a periphery of the hub, the cam shoulder having a second segmented polynomial shape of constantly changing slope which second segmented polynomial shape has the same frequency as the first segmented polynomial shape, the shoulder having at least two lobes formed by the second polynomial shape, each lobe characterized by a peak positioned between a first trough and a second trough and a lobe wavelength between the two troughs, the peak having a maximum amplitude for the lobe, where the wavelength distance from the first trough to peak along an ascending shoulder portion of the lobe is greater than the wavelength distance from the peak to the second trough along a descending shoulder portion of the lobe, wherein the number of lobes of the second cam corresponds with the number of lobes of the first cam; and wherein the cams oppose one another so that the peak of a lobe of the first cam is substantially aligned with the peak of a lobe of the second cam, but no portion of first segmented polynomial shaped shoulder is parallel with a portion of second segmented polynomial shaped shoulder. In other embodiments, the

internal combustion engine includes a driveshaft having a first end and a second end and disposed along a driveshaft axis; a piston disposed to reciprocate along a piston axis, the piston axis being parallel with but spaced apart from the driveshaft axis, and a first cam mounted on the driveshaft, the first cam comprising a cam hub attached the driveshaft, and a circumferential cam shoulder extending around a periphery of the hub, the cam shoulder having a first cam diameter and a first segmented polynomial shape, the shoulder having at least two lobes formed by the polynomial shape, each lobe characterized by a peak positioned between a first trough and a second trough, the lobe having an ascending shoulder portion between the first trough and the peak and a descending shoulder portion between the peak and the second trough, wherein the average slope of the ascending shoulder portion is greater than the average slope of the descending shoulder portion; and a second cam mounted on the driveshaft and spaced apart from the first cam, the second cam comprising a cam hub attached the driveshaft, and a circumferential cam shoulder extending around a periphery of the hub, the cam shoulder having a second segmented polynomial shape which second segmented polynomial shape has the substantially the same frequency as the first segmented polynomial shape, the shoulder having at least two lobes formed by the second polynomial shape, each lobe characterized by a peak positioned between a first trough and a second trough, the lobe having an ascending shoulder portion between the first trough and the peak and a descending shoulder portion between the peak and the second trough, wherein the average slope of the ascending shoulder portion is greater than the average slope of the descending shoulder portion, wherein the number of lobes of the second cam corresponds with the number of lobes of the first cam; and wherein the first segmented polynomial shaped shoulder and the second segmented polynomial shaped shoulder oppose one another so as to be constantly diverging or converging from one another. In other embodiments, the internal combustion engine includes a driveshaft having a first end and a second end and disposed along a driveshaft axis; a piston disposed to reciprocate along a piston axis, the piston axis being parallel with but spaced apart from the driveshaft axis, and a first cam mounted on the driveshaft, the first cam comprising a cam hub attached the driveshaft, and a circumferential cam shoulder extending around a periphery of the hub, the cam shoulder having a first cam diameter and a first segmented polynomial shape, the shoulder having at least one lobe formed by the polynomial shape, each lobe characterized by a peak positioned between a first trough and a second trough and a lobe wavelength between the two troughs, the peak having a maximum amplitude for the lobe, where the wavelength distance from the first trough to peak along an ascending shoulder portion of the lobe is greater than the wavelength distance from the peak to the second trough along a descending shoulder portion of the lobe; and a second cam mounted on the driveshaft and spaced apart from the first cam, the second cam comprising a cam hub attached the driveshaft, and a circumferential cam shoulder extending around a periphery of the hub, the cam shoulder having a second segmented polynomial shape which second segmented polynomial shape has the same frequency as the first segmented polynomial shape, the shoulder having at least one lobe formed by the second polynomial shape, each lobe characterized by a peak positioned between a first trough and a second trough and a lobe wavelength between the two troughs, the peak having a maximum amplitude for the lobe, where the wavelength distance from the first trough

to peak along an ascending shoulder portion of the lobe is greater than the wavelength distance from the peak to the second trough along a descending shoulder portion of the lobe, wherein the number of lobes of the second cam corresponds with the number of lobes of the first cam; and wherein the cams oppose one another so that the peak of a lobe of the first cam is substantially aligned with the peak of a lobe of the second cam, but no portion of first segmented polynomial shaped shoulder is parallel with a portion of second segmented polynomial shaped shoulder. In other embodiments, the internal combustion engine includes a driveshaft having a first end and a second end and disposed along a driveshaft axis; a piston disposed to reciprocate along a piston axis, the piston axis being parallel with but spaced apart from the driveshaft axis, and a first cam mounted on the driveshaft, the first cam comprising a cam hub attached the driveshaft, and a circumferential cam shoulder extending around a periphery of the hub, the cam shoulder having a first cam diameter and a first segmented polynomial shape, the shoulder having at least one lobe formed by the polynomial shape, each lobe characterized by a peak positioned between a first trough and a second trough, the lobe having an ascending shoulder portion between the first trough and the peak and a descending shoulder portion between the peak and the second trough, wherein the average slope of the ascending shoulder portion is greater than the average slope of the descending shoulder portion; and a second cam mounted on the driveshaft and spaced apart from the first cam, the second cam comprising a cam hub attached the driveshaft, and a circumferential cam shoulder extending around a periphery of the hub, the cam shoulder having a second segmented polynomial shape which second segmented polynomial shape has the same frequency as the first segmented polynomial shape, the shoulder having at least one lobe formed by the second polynomial shape, each lobe characterized by a peak positioned between a first trough and a second trough, the lobe having an ascending shoulder portion between the first trough and the peak and a descending shoulder portion between the peak and the second trough, wherein the average slope of the ascending shoulder portion is greater than the average slope of the descending shoulder portion, wherein the number of lobes of the second cam corresponds with the number of lobes of the first cam; and wherein the first segmented polynomial shaped shoulder and the second segmented polynomial shaped shoulder oppose one another so as to be constantly diverging or converging from one another.

The following elements may be combined alone or in combination with any other elements for any of the foregoing engine embodiments:

At least 4 cylinders symmetrically spaced around the driveshaft.

A second combustion cylinder having a first end and a second end, the second combustion cylinder defined along the center cylinder axis so as to be axially aligned with the first combustion cylinder; a third piston assembly disposed in the first cylinder end of the second combustion cylinder; and an opposing fourth piston assembly disposed in the second cylinder end of the second combustion cylinder.

The third piston assembly engages the curvilinear shaped shoulder of the second cam.

A third cam mounted on the driveshaft and spaced apart from the second cam, the third cam having a circumferential shoulder of a third curvilinear shape, wherein the fourth piston assembly engages the curvilinear shaped shoulder of the third cam.

Two or more combustion cylinders axially aligned along the central cylinder axis, each combustion cylinder having a first end and a second end with a piston assembly disposed in each cylinder end so that piston heads of the piston assemblies of a cylinder oppose one another within the cylinder.

Three or more cams coaxially mounted on the driveshaft and spaced apart from one another, each cam having a cylindrical shoulder of curvilinear shape, wherein each cam positioned between two successive combustion cylinders is engaged by a piston assembly extending from each of the successive combustion cylinders.

First, second and third piston assemblies, each comprising a piston arm having a first end and a second end, with a piston attached to the first end of the piston arm and a cam follower attached to the second end of the piston arm, wherein the cam follower assembly includes an elongated body having a first end and a second end, wherein the elongated body is generally cylindrically shaped at each end, the elongated body having an axially extending first slot formed in the body adjacent the first end and an axially extending second slot formed in the body adjacent the second; a first roller mounted to the body in first slot; and a second roller mounted to the body in second slot.

The first roller of the first piston assembly has a larger diameter than the second roller of the first piston assembly; the first roller of the second piston assembly has a larger diameter than the second roller of the second piston assembly; and the first roller of the third piston assembly is the same diameter as the second roller of the third piston assembly.

The first roller has a diameter that is larger than the diameter of the second roller.

The combustion cylinder further comprises a cylinder wall and the exhaust port comprises a plurality of exhaust slots formed in the cylinder wall between the fuel injector and the second end, each exhaust slot extending along a slot axis generally parallel with the central cylinder axis, the intake port comprising a plurality of intake slots formed in the cylinder wall between the fuel injector and the first end, each intake slot extending along a slot axis generally diagonal with the central cylinder axis.

The exhaust slots only extend around a portion of a periphery of the cylinder.

The exhaust slots extend around no more than 180 degrees of the periphery of the cylinder.

The exhaust slots extend around no more than 90 degrees of the periphery of the cylinder.

The intake slots only extend around a portion of a periphery of the cylinder.

The intake slots extend around no more than 180 degrees of the periphery of the cylinder.

The intake slots extend around no more than 90 degrees of the periphery of the cylinder.

At least one annular flow manifold extending at least partially around the driveshaft, the annular flow manifold fluidically connecting the ports of two or more combustion cylinders.

The annular flow manifold is an annular intake manifold fluidically connecting the intake ports of two or more combustion cylinders.

The annular flow manifold is an annular exhaust manifold fluidically connecting the exhaust ports of two or more combustion cylinders.

Wherein the annular flow manifold extends fully around the driveshaft and forms an annular flowpath around the driveshaft fluidically connecting the intake or exhaust ports of all combustion cylinders.

An annular intake manifold extending at least partially around the driveshaft and fluidically connecting the intake ports of two or more combustion cylinders; and an annular exhaust manifold extending at least partially around the driveshaft, spaced axially apart from the annular intake manifold, the annular exhaust manifold fluidically connecting the exhaust ports of two or more combustion cylinders.

The annular intake manifold extends fully around the driveshaft and forms an annular combustion air flowpath around the driveshaft fluidically connecting the intake ports of all combustion cylinders and wherein the annular exhaust manifold extends fully around the driveshaft and forms an annular exhaust flowpath around the driveshaft fluidically connecting the exhaust ports of all combustion cylinders.

An engine block in which the driveshaft and combustion cylinder are supported, the engine block extends between a first end and a second end and includes an annular body portion therebetween, which annular body portion is characterized by an exterior surface and in which is formed a first annular channel and a second annular channel spaced apart from one another, the first annular channel in fluid communication with the intake port of the combustion cylinder and the second annular channel in fluid communication with the exhaust port of the combustion cylinder.

The annular channels extend from the exterior surface inwardly towards the driveshaft.

At least one annular channel extends around the entire circumference of the annular body portion.

At least one annular channel extends around only a portion of the circumference of the annular body portion.

The first and second annular channels are spaced apart from one another about the center of the annular body portion.

The engine block comprises a cylinder bore extending axially through the engine block and intersecting both of the annular channels, the combustion cylinder mounted in the cylinder bore so that the intake port aligns with the first annular channel and the exhaust port aligns with the second annular channel.

At least three cylinder bores extending axially through the engine block and intersecting both of the annular channels, the cylinder bores symmetrically spaced about the driveshaft, each cylinder bore having a combustion cylinder mounted therein, each combustion cylinder having an intake port in fluid communication with the first annular channel and an exhaust port in fluid communication with the second annular channel, each combustion cylinder further having a first end and a second end with a piston assembly disposed in each cylinder end so that piston heads of the piston assemblies of a cylinder oppose one another within the cylinder.

A fuel injector port formed in the exterior surface of the annular body portion adjacent the center of the annular body portion and extending towards the combustion cylinder, wherein the fuel injector is mounted in the fuel injector port.

A sparkplug port formed in the exterior surface of the annular body portion adjacent the fuel injector port, the spark plug port extending towards the combustion cylinder.

The first cam comprises a hub mounted on driveshaft with the circumferential shoulder extending around a periphery of hub, the curvilinear shaped first cam shoulder has at least two peaks and at least two troughs formed by the shoulder, wherein each trough includes a substantially flat portion at

its base and wherein each peak is rounded at its apex; the second cam comprises a hub mounted on driveshaft with the circumferential shoulder extending around a periphery of hub, the curvilinear shaped second cam shoulder has at least two crests and at least two troughs formed by the shoulder and corresponding in number to the crests and troughs of the first cam, wherein each trough of the second cam is rounded at its base and wherein each peak includes a substantially flat portion at its apex.

The first cam comprises a hub mounted on driveshaft with the circumferential shoulder extending around a periphery of hub, the curvilinear shaped first cam shoulder has at least two peaks having a first peak amplitude and at least two troughs having a first trough amplitude, wherein the first trough amplitude is less than the first peak amplitude; the second cam comprises a hub mounted on driveshaft with the circumferential shoulder extending around a periphery of hub, the curvilinear shaped second cam shoulder has at least two peaks having a second peak amplitude and at least two troughs having a second trough amplitude, wherein the second trough amplitude is greater than the second peak amplitude.

The second cam has a second cam diameter which second cam diameter is the same as the first cam diameter.

The first peak amplitude is substantially equivalent to the second trough amplitude, and the first trough amplitude is substantially equivalent to the second peak amplitude.

The first and second cams have the same number of peaks and troughs.

The curvilinear shape of the first cam has a curvilinear frequency that is the same as the curvilinear frequency of the curvilinear shape of the second cam.

The amplitude of the curvilinear shaped shoulders of each cam is the same.

The shoulder of each cam has at least four crests and at least four troughs.

Each curvilinear shaped cam shoulder comprises an inwardly facing track and an outwardly facing track.

Each cam includes a cam index and each cam is mounted on the driveshaft and radially indexed with a driveshaft index, wherein the first cam and the second cam have the same curvilinear shape, and wherein one cam is angularly displaced on the driveshaft an angle of between zero and fifteen degrees relative to the other cam.

The angular displacement between the first and second cams is between 0.5 to 11 degrees.

The piston assembly comprises a piston arm having a first annular body of a piston arm diameter spaced apart from a second annular body having a similar piston arm diameter and interconnected by a smaller diameter neck, with a piston attached to the first annular body and a cam follower attached to the second annular body.

The neck is of solid cross-sectional area.

An annulus is formed around the neck between the first and second annular bodies.

Each annular body includes an annular groove formed around annular body with a sealing element disposed in the annular groove.

The piston assemblies each comprises a piston arm having a first end and a second end, with a piston attached to the first end of the piston arm.

A first cam follower linked to first and third piston assemblies and a second cam follower linked to the second and fourth piston assemblies, each cam follower assembly includes an elongated body having a first end and a second end, wherein the elongated body is generally cylindrically shaped at each end, which ends are interconnected by an

arm, the elongated body having an axially extending first slot formed in the body adjacent the first end and an axially extending second slot formed in the body adjacent the second; a first roller mounted to the body in the first slot; and a second roller mounted to the body in the second slot; and wherein the third and fourth piston assemblies each comprise a piston arm having a first end and a second end, wherein the first cam follower engages the curvilinear shaped shoulder of the first cam and the second cam follower engages the curvilinear shaped shoulder of the second cam.

The piston assembly comprises a piston arm having a first end and a second end, with a piston attached to the first end of the piston arm and a cam follower attached to the second end of the piston arm, wherein the cam follower assembly includes an elongated body having a first end and a second end, wherein the elongated body is generally cylindrically shaped at each end, which ends are interconnected by an arm within which is formed a lubrication passage extending along a portion of the length of the arm between the two ends, the elongated body having an axially extending first slot in formed in the body adjacent the first end and an axially extending second slot formed in the body adjacent the second; a first roller mounted to the body in the first slot; and a second roller mounted to the body in the second slot, wherein the lubrication passage extends in the arm between the two rollers.

The first cylindrically shaped end of the cam follower assembly is of a first diameter and the second cylindrically shaped end of the cam follower assembly is of a second diameter smaller than the first diameter.

The piston assembly comprises a piston arm having a first end and a second end, with a piston attached to the first end of the piston arm and a cam follower attached to the second end of the piston arm, wherein the cam follower assembly includes an elongated body having a first end and a second end, wherein the elongated body is generally cylindrically shaped at each end, which ends are interconnected by an arm, the elongated body having an axially extending first slot in formed in the body adjacent the first end and an axially extending second slot formed in the body adjacent the second; a first roller mounted to the body in the first slot; and a second roller mounted to the body in the second slot.

A port formed in the arm adjacent the first roller and in fluid communication with the lubrication passage, a port formed in the arm adjacent the second roller and in fluid communication with the lubrication passage, and an additional port formed in the elongated cam follower body in fluid communication with the lubrication passage.

A first roller bearing and a second roller bearing, wherein the first port is in fluid communication with the first roller bearing and the second port is in fluid communication with the second roller bearing.

The elongated body has an outer surface and the additional port is formed in the outer surface of the elongated body.

The cylindrically shaped second end of the cam follower body has a bore formed therein.

The cylindrically shaped second end of the cam follower body has a bore formed therein with a radially extending window formed in the second end and intersecting the bore.

The cam follower assembly further comprises a radially adjustable spacer pad mounted on the arm between the first and second rollers and extending inwardly of the arm between the first and second slots.

The first roller has a larger diameter than the second roller.

The first and second slots are formed along a plane and each roller has a rotational axis that is generally parallel with

the rotational axis of the other roller and which axii are generally perpendicular to the plane along which the slots are formed.

The cam follower of the piston assembly engages the curvilinear shaped shoulder of a cam.

Each curvilinear shaped cam shoulder comprises an inwardly facing track facing the combustion cylinder and an outwardly facing track facing away from the combustion chamber, wherein the first roller bears against the inwardly facing track and the second roller bears against the outwardly facing track.

The adjustable spacer pad bears against the outer edge of the curvilinear shoulder.

The larger diameter first roller bears against the inwardly facing track and the smaller diameter second roller bears against the outwardly facing track.

A guidance cap coaxially mounted around a driveshaft end, outwardly of the cam between the cam and the driveshaft end, wherein the guidance cap comprises a central bore through which the driveshaft extends and two or more symmetrically positioned follower bores radially spaced outward of central bore with each follower bore slidingly receiving the cylindrically shaped second end of a cam follower assembly.

An engine block in which the driveshaft is supported, the engine block extending between a first end and a second end and includes an annular body portion therebetween, which annular body is generally coaxial with the driveshaft, and which annular body portion is characterized by an exterior surface, wherein at least one cylinder bore radially spaced apart from the driveshaft but parallel therewith is formed in the engine block and coaxial with a follower bore of the guidance cap.

The guidance cap comprises at least six symmetrically spaced follower bores, each slidingly receiving the cylindrically shaped second end of a cam follower assembly.

The follower bores are of a diameter less than the bores of the engine block.

The guidance cap comprises a port formed within the bore disposed to align with the port along the outer surface of the elongated body of the cam follower assembly.

A first guidance cap positioned adjacent the first end of the driveshaft and a second guidance cap positioned adjacent the second end of the driveshaft.

The piston assembly comprises a piston arm having a first end and a second end, with a piston attached to the first end of the piston arm and a cam follower attached to the second end of the piston arm, wherein the piston is formed of an annular body having a first end attached to piston arm and a second end, with a crown formed at the second end of the annular body, the crown having an indentation formed in an outwardly facing crown surface.

The indentation has an indentation depth.

The intention is conically shaped about the primary axis of the piston.

A notch formed at the periphery of annular body and extending inward to intersect with the indentation.

The notch has a notch depth no deeper than indentation depth.

The notch extends no more than approximately 90 degrees around the periphery of annular body.

The notch extends no more than approximately 60 degrees around the periphery of annular body.

The notch extends between 5 and 30 degrees around the periphery of annular body.

A portion of the fuel injector extends into the notch when the piston assembly is extended to the inner dead center position.

A portion of the notch extends around a portion of the fuel injector when the piston assembly is extended to the inner dead center position.

A first link interconnecting the first and third piston assemblies and a second link interconnecting the second and fourth piston assemblies.

The first and second piston assemblies each comprises a piston arm having a first end and a second end, with a piston attached to the first end of the piston arm and a cam follower attached to the second end of the piston arm, wherein the cam follower assembly includes an elongated body having a first end and a second end, wherein the elongated body is generally cylindrically shaped at each end, which ends are interconnected by an arm, the elongated body having an axially extending first slot formed in the body adjacent the first end and an axially extending second slot formed in the body adjacent the second; a first roller mounted to the body in the first slot; and a second roller mounted to the body in the second slot; and wherein the third and fourth piston assemblies each comprise a piston arm having a first end and a second end, with a piston attached to the first end of the piston arm.

A first link interconnecting the first and third piston assemblies and a second link interconnecting the second and fourth piston assemblies.

The first link interconnects the cam follower assembly of the first piston assembly with the piston arm of the third piston assembly, and the second link interconnects the cam follower assembly of the second piston assembly with the piston arm of the fourth piston assembly.

The first link interconnects the piston arm of the first piston assembly with the piston arm of the third piston assembly, and the second link interconnects the piston arm of the second piston assembly with the piston arm of the fourth piston assembly.

The cam follower assembly of the first piston assembly engages the first cam and the cam follower assembly of the second piston assembly engages the second cam.

A second combustion cylinder having a first end and a second end and defined along second center cylinder axis parallel with the first combustion cylinder central axis but radially spaced outward from the first combustion cylinder central axis; a third cam mounted on the driveshaft between the first cam and the first driveshaft end, the third cam having a circumferential shoulder of a third cam diameter and a third curvilinear shape with a third frequency, the third cam diameter being larger than the first cam diameter; a fourth cam mounted on the driveshaft between the second cam and the second end of the driveshaft, the fourth cam having a circumferential shoulder of a fourth curvilinear shape which fourth curvilinear shape has the same frequency as the third curvilinear shape.

A third piston assembly disposed in the first cylinder end of the second combustion cylinder and an opposing fourth piston assembly disposed in the second cylinder end of the second combustion cylinder, the third piston assembly engaging the curvilinear shaped shoulder of the third cam and the fourth piston assembly engaging the curvilinear shaped shoulder of the fourth cam, each piston assembly movable between an inner dead center position in which the piston assembly is fully extended in the combustion chamber away from its corresponding cam and an outer dead

center position in which the piston assembly is fully retracted in the combustion chamber away from the inner dead center position.

The fourth cam has a fourth cam diameter which fourth cam diameter is the same as the third cam diameter.

The frequency of the third cam is less than the frequency of the first cam.

The curvilinear shaped first cam shoulder of the first cam has at least two peaks having a first peak amplitude and at least two troughs having a first trough amplitude; and the curvilinear shaped third cam shoulder has at least two peaks having a second peak amplitude and at least two troughs having a second trough amplitude, wherein the amplitudes of the third cam shoulder are less than the amplitudes of the first cam shoulder.

Comprising a piston arm having a first end and a second end, with a piston attached to the first end of the piston arm and a cam follower attached to the second end of the piston arm, wherein the cam follower assembly includes an elongated body having a first end and a second end, the elongated body having an axially extending first slot formed in the body adjacent the first end and an axially extending second slot formed in the body adjacent the second; a first roller mounted to the body in first slot; and a second roller mounted to the body in second slot.

The second cam has a second cam diameter which second cam diameter is the same as the first cam diameter.

The curvilinear shape is sinusoidal shape.

The curvilinear shape is a segmented polynomial shape.

The cams are substantially in phase so that the peak of a lobe of the first cam is aligned with and substantially mirrors the peak of a lobe of the second cam.

The cams are substantially in phase so that the peak of each lobe of the first cam is aligned with and substantially mirrors a peak of each lobe of the second cam.

The average slope of the descending shoulder portion is greater than 45 degrees.

Each lobe is asymmetrical about its peak.

A segment of the shoulder shape extending from a peak towards the second trough is linear.

The linear segment of shoulder shape extending from a lobe peak has a slope greater than zero and less than 20 degrees.

Each adjacent lobe has a linear segment of shoulder shape extending from the lobe peak, and the linear segments have a changing slope that is the same.

The slope of the descending shoulder portion of a lobe of the first cam is the same as the slope of the descending shoulder portion of an adjacent lobe of the second cam.

The segmented polynomial shaped shoulder of the first cam has the same shape as the segmented polynomial shaped shoulder of the second cam.

The descending portions of the segmented polynomial shaped shoulder of the first cam have the same shape as the descending portions of the segmented polynomial shaped track of the second cam.

The ascending portions of the segmented polynomial shaped shoulder of the first cam have the same shape as the ascending portions of the segmented polynomial shaped shoulder of the second cam.

The ascending portions of the segmented polynomial shaped shoulder of the first cam have a different shape than the ascending portions of the segmented polynomial shaped shoulder of the second cam.

A combustion cylinder defined along the piston axis, the combustion cylinder having a first end and a second end with an intake port formed in the cylinder between the first and

second ends and having an outer port edge closest to the first end and an inner port edge closest to the second end, an exhaust port formed in the cylinder between the intake port and the second end and having an outer port edge closest to the second end and an inner port edge closest to the first end, with inner dead center of the combustion cylinder defined approximately equidistance between the outer edge of the intake port and the outer edge of the exhaust port.

The inner port edge of the exhaust port is closer to inner dead center than the inner port edge of the intake port.

A first piston is reciprocatingly disposed in the first cylinder end of the combustion cylinder and engages the first cam along the first segmented polynomial shaped shoulder, and an opposing second piston is reciprocatingly disposed in the second cylinder end of the combustion cylinder and engages the second cam along the second segmented polynomial shaped shoulder.

The first piston and second piston are adjacent inner dead center of the combustion cylinder when the first piston engages the first cam at the peak of a first cam lobe, the first piston blocking flow through the intake port and the second piston blocking flow through the exhaust port.

The first piston is adjacent the outer edge of the intake port and second piston is adjacent the outer edge of the exhaust port when the first piston engages the first cam at a trough along the first segmented polynomial shaped shoulder.

The first piston blocks flow through the intake port when the first piston engages the first cam along a descending shoulder portion of a lobe of the first cam and the second piston is spaced apart from the inner port edge of the exhaust port when the first piston engages the first cam along the descending shoulder portion of the lobe.

The second piston blocks flow through the exhaust port when the second piston engages the second cam along an ascending shoulder portion of a lobe of the second cam and the first piston is spaced apart from the inner port edge of the intake port when the second piston engages the second cam along the ascending shoulder portion of the lobe.

A combustion chamber is defined within the cylinder between the two cylinder ends, the combustion cylinder further comprising a cylinder wall and the exhaust port comprises a plurality of exhaust slots formed in the cylinder wall between the fuel injector and the second end, each exhaust slot extending along a slot axis generally parallel with the central cylinder axis, the intake port comprising a plurality of intake slots formed in the cylinder wall between the fuel injector and the first end, each intake slot extending along a slot axis generally diagonal with the central cylinder axis.

A fuel injection port formed in the cylinder wall at inner dead center of the combustion cylinder.

A spark plug port formed in the cylinder wall between the plurality of exhaust slots and the plurality of intake slots.

The first and second segmented polynomial shaped shoulders are symmetric in shape extending from a respective lobe peak to a point along the descending shoulder portion and asymmetric in shape along the shoulders extending from the respective second trough to the lobe peak.

Each cam has a single lobe and the first trough and second trough are the same.

An engine block in which the driveshaft is supported, the engine block extending between a first end and a second end and includes an annular body portion therebetween, which annular body is generally coaxial with the driveshaft, and which annular body portion is characterized by an exterior

surface, wherein at least one cylinder bore radially spaced apart from the driveshaft but parallel therewith is formed in the engine block.

The engine block comprises a first annular channel and a second annular channel spaced apart from one another, the first annular channel in fluid communication with the intake port of the combustion cylinder and the second annular channel in fluid communication with the exhaust port of the combustion cylinder.

A driveshaft having a first end and a second end and disposed along a driveshaft axis; a first cam mounted on the driveshaft, the first cam having a circumferential shoulder of a first cam diameter and a first curvilinear shape with a first frequency; a second cam mounted on the driveshaft spaced apart from the first cam, the second cam having a circumferential shoulder of a second curvilinear shape which second curvilinear shape has the same frequency as the first curvilinear shape; a first combustion cylinder defined along a center cylinder axis, the combustion cylinder having a first end and a second end with an intake port formed in the cylinder between the first and second ends and an exhaust port formed in the cylinder between the intake port and the second end, the center cylinder axis being parallel with but spaced apart from the driveshaft axis, wherein a combustion chamber is defined within the cylinder between the two cylinder ends; a first piston assembly disposed in the first cylinder end of the first combustion cylinder and an opposing second piston assembly disposed in the second cylinder end of the first combustion cylinder, the first piston assembly engaging the curvilinear shaped shoulder of the first cam and the second piston assembly engaging the curvilinear shaped shoulder of the second cam, each piston assembly movable between an inner dead center position in which the piston assembly is fully extended in the combustion chamber away from its corresponding cam and an outer dead center position in which the piston assembly is fully retracted in the combustion chamber away from the inner dead center position; at least one fuel injector disposed adjacent the center of the combustion cylinder and in communication with said combustion chamber; further comprising: a second combustion cylinder having a first end and a second end, the second combustion cylinder defined along the center cylinder axis so as to be axially aligned with the first combustion cylinder; a third piston assembly disposed in the first cylinder end of the second combustion cylinder; and an opposing fourth piston assembly disposed in the second cylinder end of the second combustion cylinder.

A driveshaft having a first end and a second end and disposed along a driveshaft axis; a first cam mounted on the driveshaft, the first cam having a circumferential shoulder of a first cam diameter and a first curvilinear shape with a first frequency; a second cam mounted on the driveshaft spaced apart from the first cam, the second cam having a circumferential shoulder of a second curvilinear shape which second curvilinear shape has the same frequency as the first curvilinear shape; a first combustion cylinder defined along a center cylinder axis, the combustion cylinder having a first end and a second end with an intake port formed in the cylinder between the first and second ends and an exhaust port formed in the cylinder between the intake port and the second end, the center cylinder axis being parallel with but spaced apart from the driveshaft axis, wherein a combustion chamber is defined within the cylinder between the two cylinder ends; a first piston assembly disposed in the first cylinder end of the first combustion cylinder and an opposing second piston assembly disposed in the second cylinder end of the first combustion cylinder, the first piston assembly

engaging the curvilinear shaped shoulder of the first cam and the second piston assembly engaging the curvilinear shaped shoulder of the second cam, each piston assembly movable between an inner dead center position in which the piston assembly is fully extended in the combustion chamber away from its corresponding cam and an outer dead center position in which the piston assembly is fully retracted in the combustion chamber away from the inner dead center position; at least one fuel injector disposed adjacent the center of the combustion cylinder and in communication with said combustion chamber; further comprising two or more combustion cylinders axially aligned along the central cylinder axis, each combustion cylinder having a first end and a second end with a piston assembly disposed in each cylinder end so that piston heads of the piston assemblies of a cylinder oppose one another within the cylinder.

A driveshaft having a first end and a second end and disposed along a driveshaft axis; a first cam mounted on the driveshaft, the first cam having a circumferential shoulder of a first cam diameter and a first curvilinear shape with a first frequency; a second cam mounted on the driveshaft spaced apart from the first cam, the second cam having a circumferential shoulder of a second curvilinear shape which second curvilinear shape has the same frequency as the first curvilinear shape; a first combustion cylinder defined along a center cylinder axis, the combustion cylinder having a first end and a second end with an intake port formed in the cylinder between the first and second ends and an exhaust port formed in the cylinder between the intake port and the second end, the center cylinder axis being parallel with but spaced apart from the driveshaft axis, wherein a combustion chamber is defined within the cylinder between the two cylinder ends; a first piston assembly disposed in the first cylinder end of the first combustion cylinder and an opposing second piston assembly disposed in the second cylinder end of the first combustion cylinder, the first piston assembly engaging the curvilinear shaped shoulder of the first cam and the second piston assembly engaging the curvilinear shaped shoulder of the second cam, each piston assembly movable between an inner dead center position in which the piston assembly is fully extended in the combustion chamber away from its corresponding cam and an outer dead center position in which the piston assembly is fully retracted in the combustion chamber away from the inner dead center position; at least one fuel injector disposed adjacent the center of the combustion cylinder and in communication with said combustion chamber; wherein the combustion cylinder further comprises a cylinder wall and the exhaust port comprises a plurality of exhaust slots formed in the cylinder wall between the fuel injector and the second end, each exhaust slot extending along a slot axis generally parallel with the central cylinder axis, the intake port comprising a plurality of intake slots formed in the cylinder wall between the fuel injector and the first end, each intake slot extending along a slot axis generally diagonal with the central cylinder axis.

A driveshaft having a first end and a second end and disposed along a driveshaft axis; a first cam mounted on the driveshaft, the first cam having a circumferential shoulder of a first cam diameter and a first curvilinear shape with a first frequency; a second cam mounted on the driveshaft spaced apart from the first cam, the second cam having a circumferential shoulder of a second curvilinear shape which second curvilinear shape has the same frequency as the first curvilinear shape; a first combustion cylinder defined along a center cylinder axis, the combustion cylinder having a first end and a second end with an intake port formed in the cylinder between the first and second ends and an exhaust

51

port formed in the cylinder between the intake port and the second end, the center cylinder axis being parallel with but spaced apart from the driveshaft axis, wherein a combustion chamber is defined within the cylinder between the two cylinder ends; a first piston assembly disposed in the first cylinder end of the first combustion cylinder and an opposing second piston assembly disposed in the second cylinder end of the first combustion cylinder, the first piston assembly engaging the curvilinear shaped shoulder of the first cam and the second piston assembly engaging the curvilinear shaped shoulder of the second cam, each piston assembly movable between an inner dead center position in which the piston assembly is fully extended in the combustion chamber away from its corresponding cam and an outer dead center position in which the piston assembly is fully retracted in the combustion chamber away from the inner dead center position; at least one fuel injector disposed adjacent the center of the combustion cylinder and in communication with said combustion chamber; further comprising at least one annular flow manifold extending at least partially around the driveshaft, the annular flow manifold fluidically connecting the ports of two or more combustion cylinders.

A driveshaft having a first end and a second end and disposed along a driveshaft axis; a first cam mounted on the driveshaft, the first cam having a circumferential shoulder of a first cam diameter and a first curvilinear shape with a first frequency; a second cam mounted on the driveshaft spaced apart from the first cam, the second cam having a circumferential shoulder of a second curvilinear shape which second curvilinear shape has the same frequency as the first curvilinear shape; a first combustion cylinder defined along a center cylinder axis, the combustion cylinder having a first end and a second end with an intake port formed in the cylinder between the first and second ends and an exhaust port formed in the cylinder between the intake port and the second end, the center cylinder axis being parallel with but spaced apart from the driveshaft axis, wherein a combustion chamber is defined within the cylinder between the two cylinder ends; a first piston assembly disposed in the first cylinder end of the first combustion cylinder and an opposing second piston assembly disposed in the second cylinder end of the first combustion cylinder, the first piston assembly engaging the curvilinear shaped shoulder of the first cam and the second piston assembly engaging the curvilinear shaped shoulder of the second cam, each piston assembly movable between an inner dead center position in which the piston assembly is fully extended in the combustion chamber away from its corresponding cam and an outer dead center position in which the piston assembly is fully retracted in the combustion chamber away from the inner dead center position; at least one fuel injector disposed adjacent the center of the combustion cylinder and in communication with said combustion chamber; further comprising an annular intake manifold extending at least partially around the driveshaft and fluidically connecting the intake ports of two or more combustion cylinders; and an annular exhaust manifold extending at least partially around the driveshaft, spaced axially apart from the annular intake manifold, the annular exhaust manifold fluidically connecting the exhaust ports of two or more combustion cylinders.

A driveshaft having a first end and a second end and disposed along a driveshaft axis; a first cam mounted on the driveshaft, the first cam having a circumferential shoulder of a first cam diameter and a first curvilinear shape with a first frequency; a second cam mounted on the driveshaft spaced apart from the first cam, the second cam having a circumferential shoulder of a second curvilinear shape which

52

second curvilinear shape has the same frequency as the first curvilinear shape; a first combustion cylinder defined along a center cylinder axis, the combustion cylinder having a first end and a second end with an intake port formed in the cylinder between the first and second ends and an exhaust port formed in the cylinder between the intake port and the second end, the center cylinder axis being parallel with but spaced apart from the driveshaft axis, wherein a combustion chamber is defined within the cylinder between the two cylinder ends; a first piston assembly disposed in the first cylinder end of the first combustion cylinder and an opposing second piston assembly disposed in the second cylinder end of the first combustion cylinder, the first piston assembly engaging the curvilinear shaped shoulder of the first cam and the second piston assembly engaging the curvilinear shaped shoulder of the second cam, each piston assembly movable between an inner dead center position in which the piston assembly is fully extended in the combustion chamber away from its corresponding cam and an outer dead center position in which the piston assembly is fully retracted in the combustion chamber away from the inner dead center position; at least one fuel injector disposed adjacent the center of the combustion cylinder and in communication with said combustion chamber; further comprising an engine block in which the driveshaft and combustion cylinder are supported, the engine block extends between a first end and a second end and includes an annular body portion therebetween, which annular body portion is characterized by an exterior surface and in which is formed a first annular channel and a second annular channel spaced apart from one another, the first annular channel in fluid communication with the intake port of the combustion cylinder and the second annular channel in fluid communication with the exhaust port of the combustion cylinder.

A driveshaft having a first end and a second end and disposed along a driveshaft axis; a first cam mounted on the driveshaft, the first cam having a circumferential shoulder of a first cam diameter and a first curvilinear shape with a first frequency; a second cam mounted on the driveshaft spaced apart from the first cam, the second cam having a circumferential shoulder of a second curvilinear shape which second curvilinear shape has the same frequency as the first curvilinear shape; a first combustion cylinder defined along a center cylinder axis, the combustion cylinder having a first end and a second end with an intake port formed in the cylinder between the first and second ends and an exhaust port formed in the cylinder between the intake port and the second end, the center cylinder axis being parallel with but spaced apart from the driveshaft axis, wherein a combustion chamber is defined within the cylinder between the two cylinder ends; a first piston assembly disposed in the first cylinder end of the first combustion cylinder and an opposing second piston assembly disposed in the second cylinder end of the first combustion cylinder, the first piston assembly engaging the curvilinear shaped shoulder of the first cam and the second piston assembly engaging the curvilinear shaped shoulder of the second cam, each piston assembly movable between an inner dead center position in which the piston assembly is fully extended in the combustion chamber away from its corresponding cam and an outer dead center position in which the piston assembly is fully retracted in the combustion chamber away from the inner dead center position; at least one fuel injector disposed adjacent the center of the combustion cylinder and in communication with said combustion chamber; wherein the first cam comprises a hub mounted on driveshaft with the circumferential shoulder extending around a periphery of hub, the curvilinear shaped

53

first cam shoulder has at least two peaks and at least two troughs formed by the shoulder, wherein each trough includes a substantially flat portion at its base and wherein each peak is rounded at its apex; the second cam comprises a hub mounted on driveshaft with the circumferential shoulder extending around a periphery of hub, the curvilinear shaped second cam shoulder has at least two crests and at least two troughs formed by the shoulder and corresponding in number to the crests and troughs of the first cam, wherein each trough of the second cam is rounded at its base and wherein each peak includes a substantially flat portion at its apex.

A driveshaft having a first end and a second end and disposed along a driveshaft axis; a first cam mounted on the driveshaft, the first cam having a circumferential shoulder of a first cam diameter and a first curvilinear shape with a first frequency; a second cam mounted on the driveshaft spaced apart from the first cam, the second cam having a circumferential shoulder of a second curvilinear shape which second curvilinear shape has the same frequency as the first curvilinear shape; a first combustion cylinder defined along a center cylinder axis, the combustion cylinder having a first end and a second end with an intake port formed in the cylinder between the first and second ends and an exhaust port formed in the cylinder between the intake port and the second end, the center cylinder axis being parallel with but spaced apart from the driveshaft axis, wherein a combustion chamber is defined within the cylinder between the two cylinder ends; a first piston assembly disposed in the first cylinder end of the first combustion cylinder and an opposing second piston assembly disposed in the second cylinder end of the first combustion cylinder, the first piston assembly engaging the curvilinear shaped shoulder of the first cam and the second piston assembly engaging the curvilinear shaped shoulder of the second cam, each piston assembly movable between an inner dead center position in which the piston assembly is fully extended in the combustion chamber away from its corresponding cam and an outer dead center position in which the piston assembly is fully retracted in the combustion chamber away from the inner dead center position; at least one fuel injector disposed adjacent the center of the combustion cylinder and in communication with said combustion chamber; wherein the first cam comprises a hub mounted on driveshaft with the circumferential shoulder extending around a periphery of hub, the curvilinear shaped first cam shoulder has at least two peaks having a first peak amplitude and at least two troughs having a first trough amplitude, wherein the first trough amplitude is less than the first peak amplitude; and the second cam comprises a hub mounted on driveshaft with the circumferential shoulder extending around a periphery of hub, the curvilinear shaped second cam shoulder has at least two peaks having a second peak amplitude and at least two troughs having a second trough amplitude, wherein the second trough amplitude is greater than the second peak amplitude.

A driveshaft having a first end and a second end and disposed along a driveshaft axis; a first cam mounted on the driveshaft, the first cam having a circumferential shoulder of a first cam diameter and a first curvilinear shape with a first frequency; a second cam mounted on the driveshaft spaced apart from the first cam, the second cam having a circumferential shoulder of a second curvilinear shape which second curvilinear shape has the same frequency as the first curvilinear shape; a first combustion cylinder defined along a center cylinder axis, the combustion cylinder having a first end and a second end with an intake port formed in the cylinder between the first and second ends and an exhaust

54

port formed in the cylinder between the intake port and the second end, the center cylinder axis being parallel with but spaced apart from the driveshaft axis, wherein a combustion chamber is defined within the cylinder between the two cylinder ends; a first piston assembly disposed in the first cylinder end of the first combustion cylinder and an opposing second piston assembly disposed in the second cylinder end of the first combustion cylinder, the first piston assembly engaging the curvilinear shaped shoulder of the first cam and the second piston assembly engaging the curvilinear shaped shoulder of the second cam, each piston assembly movable between an inner dead center position in which the piston assembly is fully extended in the combustion chamber away from its corresponding cam and an outer dead center position in which the piston assembly is fully retracted in the combustion chamber away from the inner dead center position; at least one fuel injector disposed adjacent the center of the combustion cylinder and in communication with said combustion chamber; wherein the piston assembly comprises a piston arm having a first annular body of a piston arm diameter spaced apart from a second annular body having a similar piston arm diameter and interconnected by a smaller diameter neck, with a piston attached to the first annular body and a cam follower attached to the second annular body.

A driveshaft having a first end and a second end and disposed along a driveshaft axis; a first cam mounted on the driveshaft, the first cam having a circumferential shoulder of a first cam diameter and a first curvilinear shape with a first frequency; a second cam mounted on the driveshaft spaced apart from the first cam, the second cam having a circumferential shoulder of a second curvilinear shape which second curvilinear shape has the same frequency as the first curvilinear shape; a first combustion cylinder defined along a center cylinder axis, the combustion cylinder having a first end and a second end with an intake port formed in the cylinder between the first and second ends and an exhaust port formed in the cylinder between the intake port and the second end, the center cylinder axis being parallel with but spaced apart from the driveshaft axis, wherein a combustion chamber is defined within the cylinder between the two cylinder ends; a first piston assembly disposed in the first cylinder end of the first combustion cylinder and an opposing second piston assembly disposed in the second cylinder end of the first combustion cylinder, the first piston assembly engaging the curvilinear shaped shoulder of the first cam and the second piston assembly engaging the curvilinear shaped shoulder of the second cam, each piston assembly movable between an inner dead center position in which the piston assembly is fully extended in the combustion chamber away from its corresponding cam and an outer dead center position in which the piston assembly is fully retracted in the combustion chamber away from the inner dead center position; at least one fuel injector disposed adjacent the center of the combustion cylinder and in communication with said combustion chamber; wherein the piston assembly comprises a piston arm having a first end and a second end, with a piston attached to the first end of the piston arm and a cam follower attached to the second end of the piston arm, wherein the cam follower assembly includes an elongated body having a first end and a second end, wherein the elongated body is generally cylindrically shaped at each end, which ends are interconnected by an arm within which is formed a lubrication passage extending along a portion of the length of the arm between the two ends, the elongated body having an axially extending first slot in formed in the body adjacent the first end and an axially extending second

55

slot formed in the body adjacent the second; a first roller mounted to the body in the first slot; and a second roller mounted to the body in the second slot, wherein the lubrication passage extends in the arm between the two rollers.

A driveshaft having a first end and a second end and disposed along a driveshaft axis; a first cam mounted on the driveshaft, the first cam having a circumferential shoulder of a first cam diameter and a first curvilinear shape with a first frequency; a second cam mounted on the driveshaft spaced apart from the first cam, the second cam having a circumferential shoulder of a second curvilinear shape which second curvilinear shape has the same frequency as the first curvilinear shape; a first combustion cylinder defined along a center cylinder axis, the combustion cylinder having a first end and a second end with an intake port formed in the cylinder between the first and second ends and an exhaust port formed in the cylinder between the intake port and the second end, the center cylinder axis being parallel with but spaced apart from the driveshaft axis, wherein a combustion chamber is defined within the cylinder between the two cylinder ends; a first piston assembly disposed in the first cylinder end of the first combustion cylinder and an opposing second piston assembly disposed in the second cylinder end of the first combustion cylinder, the first piston assembly engaging the curvilinear shaped shoulder of the first cam and the second piston assembly engaging the curvilinear shaped shoulder of the second cam, each piston assembly movable between an inner dead center position in which the piston assembly is fully extended in the combustion chamber away from its corresponding cam and an outer dead center position in which the piston assembly is fully retracted in the combustion chamber away from the inner dead center position; at least one fuel injector disposed adjacent the center of the combustion cylinder and in communication with said combustion chamber; comprising a first guidance cap positioned adjacent the first end of the driveshaft and a second guidance cap positioned adjacent the second end of the driveshaft.

A driveshaft having a first end and a second end and disposed along a driveshaft axis; a first cam mounted on the driveshaft, the first cam having a circumferential shoulder of a first cam diameter and a first curvilinear shape with a first frequency; a second cam mounted on the driveshaft spaced apart from the first cam, the second cam having a circumferential shoulder of a second curvilinear shape which second curvilinear shape has the same frequency as the first curvilinear shape; a first combustion cylinder defined along a center cylinder axis, the combustion cylinder having a first end and a second end with an intake port formed in the cylinder between the first and second ends and an exhaust port formed in the cylinder between the intake port and the second end, the center cylinder axis being parallel with but spaced apart from the driveshaft axis, wherein a combustion chamber is defined within the cylinder between the two cylinder ends; a first piston assembly disposed in the first cylinder end of the first combustion cylinder and an opposing second piston assembly disposed in the second cylinder end of the first combustion cylinder, the first piston assembly engaging the curvilinear shaped shoulder of the first cam and the second piston assembly engaging the curvilinear shaped shoulder of the second cam, each piston assembly movable between an inner dead center position in which the piston assembly is fully extended in the combustion chamber away from its corresponding cam and an outer dead center position in which the piston assembly is fully retracted in the combustion chamber away from the inner dead center position; at least one fuel injector disposed adjacent the center of

56

the combustion cylinder and in communication with said combustion chamber; wherein the piston assembly comprises a piston arm having a first end and a second end, with a piston attached to the first end of the piston arm and a cam follower attached to the second end of the piston arm, wherein the piston is formed of an annular body having a first end attached to piston arm and a second end, with a crown formed at the second end of the annular body, the crown having an indentation formed in an outwardly facing crown surface.

A driveshaft having a first end and a second end and disposed along a driveshaft axis; a first cam mounted on the driveshaft, the first cam having a circumferential shoulder of a first cam diameter and a first curvilinear shape with a first frequency; a second cam mounted on the driveshaft spaced apart from the first cam, the second cam having a circumferential shoulder of a second curvilinear shape which second curvilinear shape has the same frequency as the first curvilinear shape; a first combustion cylinder defined along a center cylinder axis, the combustion cylinder having a first end and a second end with an intake port formed in the cylinder between the first and second ends and an exhaust port formed in the cylinder between the intake port and the second end, the center cylinder axis being parallel with but spaced apart from the driveshaft axis, wherein a combustion chamber is defined within the cylinder between the two cylinder ends; a first piston assembly disposed in the first cylinder end of the first combustion cylinder and an opposing second piston assembly disposed in the second cylinder end of the first combustion cylinder, the first piston assembly engaging the curvilinear shaped shoulder of the first cam and the second piston assembly engaging the curvilinear shaped shoulder of the second cam, each piston assembly movable between an inner dead center position in which the piston assembly is fully extended in the combustion chamber away from its corresponding cam and an outer dead center position in which the piston assembly is fully retracted in the combustion chamber away from the inner dead center position; at least one fuel injector disposed adjacent the center of the combustion cylinder and in communication with said combustion chamber; further comprising: a second combustion cylinder having a first end and a second end and defined along second center cylinder axis parallel with the first combustion cylinder central axis but radially spaced outward from the first combustion cylinder central axis; a third cam mounted on the driveshaft between the first cam and the first driveshaft end, the third cam having a circumferential shoulder of a third cam diameter and a third curvilinear shape with a third frequency, the third cam diameter being larger than the first cam diameter; a fourth cam mounted on the driveshaft between the second cam and the second end of the driveshaft, the fourth cam having a circumferential shoulder of a fourth curvilinear shape which fourth curvilinear shape has the same frequency as the third curvilinear shape.

A third hydraulic passage extending along the driveshaft to a third outlet and a fourth hydraulic passage extending along the driveshaft to a fourth outlet spaced apart from the third outlet; a combustion chamber coaxial with the piston axis and in which the first piston reciprocates; a second piston disposed to reciprocate within the piston chamber opposite the first piston; a third collar formed along the driveshaft adjacent the third outlet and a fourth collar formed along the driveshaft adjacent the fourth outlet, each collar extending radially outward from driveshaft; and a second cam rotatably mounted on the driveshaft adjacent the second and third collars, the second cam having a second hub having a first end mounted adjacent the third collar so

as to form a third pressure chamber between the second hub first end and the third collar, with the third outlet in fluid communication with the third pressure chamber, the second hub having a second end mounted adjacent the fourth collar so as to form a fourth pressure chamber between the second hub second end and the fourth collar, with the fourth outlet in fluid communication with fourth pressure chamber, with a circumferential cam shoulder extending around a periphery of the second hub, the cam shoulder having a second cam diameter and a second polynomial shaped track.

Aa third hydraulic passage extending along the driveshaft and a fourth hydraulic passage extending along the driveshaft, a third set of radial passages in fluid communication with the third hydraulic passage and a fourth set of radial passages in fluid communication with the fourth hydraulic passage; a combustion chamber coaxial with the piston axis and in which the first piston reciprocates; a second piston disposed to reciprocate within the piston chamber opposite the first piston; a second cam rotatably mounted on the driveshaft spaced apart from the first cam, the first cam having a second hub with a circumferential cam shoulder extending around a periphery of the second hub, the second cam shoulder having a second cam diameter and a second polynomial shaped track; a third radially extending lug formed along the driveshaft adjacent the second cam hub and a fourth radially extending lug formed along the driveshaft adjacent the second cam hub, a radial passage a radial passage of radial passages terminating in a first ported lug outlet formed in the third lug and a radial passage of of radial passages terminating in a second ported lug outlet formed in the third lug, a radial passage of the third set of radial passages terminating in a third ported lug outlet formed in the fourth lug and a radial passage of the fourth set of radial passages terminating in a fourth ported lug outlet formed in the fourth lug; a first pressure chamber formed between the third lug and the second cam hub and a second pressure chamber formed between the fourth lug and the second cam hub, the first ported lug outlet in the third lug in fluid communication with the first pressure chamber and the third ported lug outlet in the third lug in fluid communication with the second pressure chamber; a third pressure chamber formed between the third lug and the second cam hub; and a fourth pressure chamber formed between the fourth lug and the second cam hub, the second ported lug outlet of the fourth lug in fluid communication with the third pressure chamber and the fourth ported lug outlet in the fourth lug in fluid communication with the fourth pressure chamber.

The first hub comprises a hub wall having spaced apart first and second slots formed along an inner circumference of the hub wall, wherein the first lug extends into the first slot and the second lug extends into the second slot.

The first slot has a first shoulder and a second shoulder, the first pressure chamber being formed between the first shoulder and the first lug and the second pressure chamber being formed between the second shoulder and the first lug, wherein the second slot has a third shoulder and a fourth shoulder, the third pressure chamber being formed between the third shoulder and the second lug and the fourth pressure chamber being formed between the fourth shoulder and the second lug.

The first cam is rotatable relative to the driveshaft between a first radial position and a second radial position, wherein the first pressure chamber has a volume that is greater than a volume of the second pressure chamber when the first cam is in the first radial position and the second

pressure chamber has a volume that is greater than the volume of the first pressure chamber when the first cam is in the second radial position.

A hydraulic fluid source in fluid communication with each of hydraulic passages to alternatively supply pressurized fluid to one pressure chamber or another pressure chamber.

A control mechanism and a sensor, the sensor disposed to measure a condition of the engine and coupled to the control mechanism disposed to adjust the fluid source based on the measured condition in order to radially rotate the first cam relative to the driveshaft.

Each lug is integrally formed as part of driveshaft.

Thus, a method for operating an internal combustion engine has been described. In some embodiments, the method includes injecting a first fuel into a combustion chamber of the engine and utilizing the first fuel to urge axially aligned pistons apart from one another so as to drive spaced apart cams mounted on a driveshaft; rotating, relative to the driveshaft, at least one of the cams on the driveshaft from a first radial position to a second radial position; and injecting a second fuel into the combustion chamber of the engine and utilizing the second fuel to urge axially aligned pistons apart from one another so as to drive the spaced apart cams mounted on a driveshaft. In another embodiment, the method includes combusting a fuel within a combustion chamber of the engine to urge axially aligned pistons apart from one another so as to drive spaced apart cams mounted on a driveshaft parallel with the axially aligned piston; measuring a condition of the engine while the engine is operating; and rotating at least one of the cams on the driveshaft from a first radial position to a second radial position while the engine is operating, the second radial position selected based on the measured condition of the engine. In some embodiments, the method includes moving a first cam follower along a first cam from a first position on the first cam in which a first piston is at inner dead center within a combustion cylinder to a second position on the first cam in which the first piston blocks flow through an intake port in the cylinder, and simultaneously moving a second cam follower along a second cam from a first position on the second cam in which a second piston is at inner dead center within the combustion cylinder to a second position on the second cam, so as to cause the second piston to open an exhaust port in the cylinder, wherein the respective piston move axially away from one another as the respective cam followers move from the first position to the second position; continuing to move the first cam follower along the first cam from the second position to a third position on the first cam so as to cause the first piston to continue to move away from inner dead center and to open the intake port, and simultaneously moving the second cam follower along the second cam from the second position to a third position so as to cause the second piston to move away from the first piston while the exhaust port remains open to outer dead center for the second piston; continuing to move the first cam follower along the first cam from the third position to a fourth position in which the intake port remains open, and simultaneously moving the second cam follower along the second cam from the third position to a fourth position so as to cause the second piston to close the exhaust port in the cylinder, wherein the respective piston move axially towards one another as the respective cam followers move from the third position to the fourth position; continuing to move the first cam follower along the first cam from the fourth position to a fifth position so as to cause the first piston to move axially towards second piston and inner dead center, whereby movement of the first piston closes the intake port

in the cylinder, and simultaneously moving the second cam follower along the second cam from the fourth position to a fifth position so as to cause the second piston to move axially towards the first piston and inner dead center; and continuing to move the first cam follower along the first cam from the fifth position to the first position on the cam so as to cause the first piston to move axially towards second piston and inner dead center, and simultaneously moving the second cam follower along the second cam from the fifth position to the first position on the cam so as to cause the second piston to move axially towards the first piston and inner dead center.

The following steps may be combined alone or in combination with any other steps for any of the foregoing embodiments:

Altering the radial position relative to the driveshaft of at least one cam on the driveshaft based on the type of fuel injected into the combustion chamber.

Rotating comprises injecting a fluid into a fluid chamber adjacent the cam while the engine is operating in order to alter the relative radial position of the cam on the driveshaft.

The fluid is injected through a channel formed in the driveshaft.

Injecting a hydraulic fluid into a first fluid chamber while the engine is operating to alter the radial position of a cam relative to the driveshaft in a first direction; measuring an additional condition of the engine while the engine is operating and based on the measured additional condition, injecting a hydraulic fluid into a second fluid chamber while the engine is operating to alter the radial position of the cam relative to the driveshaft in a second direction opposite the first direction.

Movement of the cam followers along their respective cams from the fourth position to the fifth position causes an inertial supercharging effect within the combustion chamber.

Movement of the cam followers along their respective cams from the second position to the third position initiates scavenging.

Movement of the cam followers along their respective cams from the third position to the fourth position causes uniflow scavenging.

Movement of the cam followers along their respective cams from the second position to the third position causes the Kadenacy effect within the combustion cylinder on combustion gases.

The first and second pistons are in phase as the cam followers move along their respective cams from the first position to the second position, and the first and second pistons are out of phase as the cam followers move along their respective cams from the second position through the third, fourth and fifth positions back to the first position.

The second piston leads the first piston when the pistons are out of phase.

The pistons are continually moving within the combustion cylinder during operation of the internal combustion engine.

The pistons have a divergence rate as the cam followers move from the first position to the third position and a convergence rate as the cam followers move from the fourth position back to the first position, wherein the divergence rate of the pistons at the beginning of movement of the cam followers from the first position to the second position on their respective cams is uniform and occurs at a first divergence rate, and thereafter continued divergence of the pistons as movement of the cam followers continues from the

first position to the second position on their respective cams is uniform and occurs at a second divergence rate higher than the first divergence rate.

While various embodiments have been illustrated in detail, the disclosure is not limited to the embodiments shown. Modifications and adaptations of the above embodiments may occur to those skilled in the art. Such modifications and adaptations are in the spirit and scope of the disclosure.

The invention claimed is:

1. An internal combustion engine comprising:
  - a driveshaft having a first end and a second end and disposed along a driveshaft axis;
  - a first cam mounted on the driveshaft, the first cam having a cam hub attached the driveshaft, and a circumferential cam shoulder extending around a periphery of the hub, the cam shoulder having a first cam diameter and a first segmented polynomial shape, the shoulder having at least two lobes formed by the polynomial shape, each lobe characterized by a peak positioned between a first trough and a second trough and a lobe wavelength between the two troughs, the peak having a maximum amplitude for the lobe, where the wavelength distance from the first trough to peak of an ascending shoulder portion of the lobe is greater than the wavelength distance from the peak to the second trough of a descending shoulder portion of the lobe;
  - a second cam mounted on the driveshaft spaced apart from the first cam, the second cam having a cam hub attached the driveshaft, and a circumferential cam shoulder extending around a periphery of the hub, the cam shoulder having a second segmented polynomial shape of constantly changing slope which second segmented polynomial shape has the same frequency as the first segmented polynomial shape, the shoulder having at least two lobes formed by the second polynomial shape, each lobe characterized by a peak positioned between a first trough and a second trough and a lobe wavelength between the two troughs, the peak having a maximum amplitude for the lobe, where the wavelength distance from the first trough to peak of an ascending shoulder portion of the lobe is greater than the wavelength distance from the peak to the second trough of a descending shoulder portion of the lobe, wherein the number of lobes of the second cam corresponds with the number of lobes of the first cam;
  - a first combustion cylinder defined along a center cylinder axis, the combustion cylinder having a first end and a second end with an intake port formed in the cylinder between the first and second ends and an exhaust port formed in the cylinder between the intake port and the second end, the center cylinder axis being parallel with but spaced apart from the driveshaft axis, wherein a combustion chamber is defined within the cylinder between the two cylinder ends;
  - a first piston assembly disposed in the first cylinder end of the first combustion cylinder and an opposing second piston assembly disposed in the second cylinder end of the first combustion cylinder, the first piston assembly engaging the segmented polynomial shaped shoulder of the first cam and the second piston assembly engaging the segmented polynomial shaped shoulder of the second cam, each piston assembly movable between an inner dead center (IDC) position in which the piston assembly is fully extended in the combustion chamber away from its corresponding cam and an outer dead center position in which the piston assembly is fully

61

retracted in the combustion chamber away from the inner dead center position; and  
 at least one fuel injector disposed adjacent a center of the combustion cylinder and in communication with said combustion chamber,  
 and

wherein the cams oppose one another so that the peak of a lobe of the first cam is substantially aligned with the peak of a lobe of the second cam, but no portion of first segmented polynomial shaped shoulder is parallel with a portion of second segmented polynomial shaped shoulder.

2. The internal combustion engine of claim 1, further comprising: a second combustion cylinder having a first end and a second end, the second combustion cylinder defined along the center cylinder axis so as to be axially aligned with the first combustion cylinder; a third piston assembly disposed in the first cylinder end of the second combustion cylinder; and an opposing fourth piston assembly disposed in the second cylinder end of the second combustion cylinder, and

a first combustion cylinder defined along a center cylinder axis, the combustion cylinder having a first end and a second end with an intake port formed in the cylinder between the first and second ends and an exhaust port formed in the cylinder between the intake port and the second end, the center cylinder axis being parallel with but spaced apart from the driveshaft axis, wherein a combustion chamber is defined within the cylinder between the two cylinder ends.

3. The internal combustion engine of claim 1, wherein the combustion cylinder further comprises a cylinder wall with a combustion port formed in the cylinder wall between the intake and exhaust ports, wherein the exhaust port comprises a plurality of exhaust slots formed in the cylinder wall between the fuel injector and the second end, and the intake port comprising a plurality of intake slots formed in the cylinder wall between the fuel injector and the first end, wherein the intake port has an outer port edge and an inner port edge and the exhaust port has an outer port edge and an inner port edge, wherein the outer port edges are equidistance from the combustion port and the inner port edge of the exhaust port is closer to the combustion port than the inner port edge of the intake port.

4. The internal combustion engine of claim 1, further comprising a second combustion cylinder defined along a second combustion cylinder center cylinder axis, the second combustion cylinder having a first end and a second end with an intake port formed in the cylinder between the first and second ends and an exhaust port formed in the cylinder between the intake port and the second end, the second center cylinder axis being parallel with but spaced apart from the driveshaft axis, wherein a combustion chamber is defined within the cylinder between the two cylinder ends; and at least one annular flow manifold extending at least partially around the driveshaft, the annular flow manifold fluidically connecting the ports of two or more combustion cylinders.

5. The internal combustion engine of claim 1, further comprising an engine block in which the driveshaft and combustion cylinder are supported, the engine block extends between a first end and a second end and includes an annular body portion therebetween, which annular body portion is characterized by an exterior surface in which is formed a first annular channel and a second annular channel spaced apart from one another, the first annular channel in fluid communication with the intake port of the combustion

62

cylinder and the second annular channel in fluid communication with the exhaust port of the combustion cylinder.

6. The internal combustion engine of claim 1, wherein the piston assembly comprises a piston arm having a first annular body of a first piston arm diameter spaced apart from a second annular body having a second piston arm diameter substantially the same as the first piston diameter and interconnected by a neck having a diameter smaller than the first piston arm diameter, with a piston attached to the first annular body and a cam follower attached to the second annular body.

7. The internal combustion engine of claim 1, wherein the piston assembly comprises a piston arm having a first end and a second end, with a piston attached to the first end of the piston arm and a cam follower attached to the second end of the piston arm, wherein the cam follower assembly includes an elongated body having a first end and a second end, wherein the elongated body is generally cylindrically shaped at each end, which ends are interconnected by an arm, the elongated body having an axially extending first slot in formed in the body adjacent the first end and an axially extending second slot formed in the body adjacent the second; a first roller mounted to the body in the first slot; and a second roller mounted to the body in the second slot.

8. The internal combustion engine of claim 1, wherein the piston assembly comprises a piston arm having a first end and a second end, with a piston attached to the first end of the piston arm and a cam follower attached to the second end of the piston arm, wherein the piston is formed of an annular body having a first end attached to piston arm and a second end, with a crown formed at the second end of the annular body, the crown having an indentation formed in an outwardly facing crown surface and a radially extending notch intersecting the indentation.

9. The internal combustion engine of claim 1, further comprising: a second combustion cylinder having a first end and a second end and defined along second center cylinder axis parallel with the first combustion cylinder central axis but radially spaced outward from the first combustion cylinder central axis;

a third cam mounted on the driveshaft between the first cam and the first driveshaft end, the third cam having a circumferential shoulder of a third cam diameter and a third segmented polynomial shape with a third frequency, the third cam diameter being larger than the first cam diameter;

a fourth cam mounted on the driveshaft between the second cam and the second end of the driveshaft, the fourth cam having a circumferential shoulder of a fourth segmented polynomial shape which fourth segmented polynomial shape has the same frequency as the third segmented polynomial shape.

10. The internal combustion engine of claim 1, further comprising a first radially extending lug formed along the driveshaft adjacent the first cam hub and a second radially extending lug formed along the driveshaft adjacent the first cam hub, a radial passage of the first set of radial passages terminating in a first ported lug outlet formed in the first lug and a radial passage of the second set of radial passages terminating in a second ported lug outlet formed in the first lug, a radial passage of the first set of radial passages terminating in a third ported lug outlet formed in the second lug and a radial passage of the second set of radial passages terminating in a fourth ported lug outlet formed in the second lug,

a first pressure chamber formed between the first lug and the first cam hub and a second pressure chamber,

63

formed between the first lug and the first cam hub, the first ported lug outlet in the first lug in fluid communication with the first pressure chamber and the third ported lug outlet in the first lug in fluid communication with the second pressure chamber;

a third pressure chamber formed between the second lug and the first cam hub and a fourth pressure chamber formed between the second lug and the first cam hub, the second ported lug outlet in the second lug in fluid communication with the second pressure chamber and the fourth ported lug outlet in the second lug in fluid communication with the fourth pressure chamber.

**11.** An internal combustion engine comprising:

a driveshaft having a first end and a second end and disposed along a driveshaft axis;

a piston disposed to reciprocate along a piston axis, the piston axis being parallel with but spaced apart from the driveshaft axis, and

a first cam mounted on the driveshaft, the first cam comprising:

a first cam hub attached the driveshaft, and a circumferential cam shoulder extending around a periphery of the first cam hub, the cam shoulder having a first cam diameter and a first segmented polynomial shape, the shoulder having at least one lobe formed by the polynomial shape, each lobe characterized by a peak positioned between a first trough and a second trough and a lobe wavelength between the two troughs, the peak having a maximum amplitude for the lobe, where the wavelength distance from the first trough to peak of an ascending shoulder portion of the lobe is greater than the wavelength distance from the peak to the second trough of a descending shoulder portion of the lobe; and

a second cam mounted on the driveshaft and spaced apart from the first cam, the second cam comprising:

a second cam hub attached the driveshaft, and a circumferential cam shoulder extending around a periphery of the second cam hub, the cam shoulder having a second segmented polynomial shape which second segmented polynomial shape has the same frequency as the first segmented polynomial shape, the second cam hub shoulder having at least one lobe formed by the second polynomial shape, each lobe characterized by a peak positioned between a first trough and a second trough and a lobe wavelength between the two troughs, the peak having a maximum amplitude for the lobe, where the wavelength distance from the first trough to peak of an ascending shoulder portion of the lobe is greater than the wavelength distance from the peak to the second trough of a descending shoulder portion of the lobe,

wherein the number of lobes of the second cam corresponds with the number of lobes of the first cam; and

wherein the cams oppose one another so that the peak of a lobe of the first cam is substantially aligned with the peak of a lobe of the second cam, but no portion of first segmented polynomial shaped shoulder is parallel with a portion of second segmented polynomial shaped shoulder.

**12.** The internal combustion engine of claim **11**, wherein the cams are substantially in phase so that the peak of each lobe of the first cam is aligned with and substantially mirrors a peak of each lobe of the second cam.

**13.** The internal combustion engine of claim **11**, wherein each lobe is asymmetrical about its peak.

64

**14.** The internal combustion engine of claim **11**, wherein a segment of the shoulder shape extending from a peak towards the second trough is linear, wherein the linear segment of the shoulder shape extending from a lobe peak has a slope greater than zero and less than 20 degrees.

**15.** The internal combustion engine of claim **13**, wherein opposing lobes of the first and second cams each have a linear segment of the shoulder shape extending from the respective lobe peak, wherein the linear segments of the opposing lobes have a changing slope that is the same.

**16.** The internal combustion engine of claim **11**, wherein a slope of the descending shoulder portion of a lobe of the first cam is the same as a slope of the descending shoulder portion of an opposing lobe of the second cam.

**17.** The internal combustion engine of claim **11**, wherein the descending portions of the segmented polynomial shaped shoulder of the first cam have the same shape as the opposing descending portions of the segmented polynomial shaped track of the second cam.

**18.** The internal combustion engine of claim **17**, wherein the ascending portions of the segmented polynomial shaped shoulder of the first cam have the same shape as the opposing ascending portions of the segmented polynomial shaped shoulder of the second cam.

**19.** The internal combustion engine of claim **17**, wherein the ascending portions of the segmented polynomial shaped shoulder of the first cam have a different shape than the ascending portions of the segmented polynomial shaped shoulder of the second cam.

**20.** An internal combustion engine comprising:

a driveshaft having a first end and a second end and disposed along a driveshaft axis;

a piston disposed to reciprocate along a piston axis, the piston axis being parallel with but spaced apart from the driveshaft axis, and

a first cam mounted on the driveshaft, the first cam comprising

a cam hub attached the driveshaft, and a circumferential cam shoulder extending around a periphery of the hub, the cam shoulder having a first cam diameter and a first segmented polynomial shape, the shoulder having at least one lobe formed by the polynomial shape, each lobe characterized by a peak positioned between a first trough and a second trough, the lobe having an ascending shoulder portion between the first trough and the peak and a descending shoulder portion between the peak and the second trough, wherein the average slope of the ascending shoulder portion is greater than the average slope of the descending shoulder portion; and

a second cam mounted on the driveshaft and spaced apart from the first cam, the second cam comprising

a cam hub attached the driveshaft, and a circumferential cam shoulder extending around a periphery of the hub, the cam shoulder having a second segmented polynomial shape which second segmented polynomial shape has the same frequency as the first segmented polynomial shape, the shoulder having at least one lobe formed by the second polynomial shape, each lobe characterized by a peak positioned between a first trough and a second trough, the lobe having an ascending shoulder portion between the first trough and the peak and a descending shoulder portion between the peak and the second trough, wherein the average slope of the ascending shoulder portion is greater than the average slope of the descending shoulder portion,

wherein the number of lobes of the second cam corresponds with the number of lobes of the first cam; and

65

wherein the first segmented polynomial shaped shoulder and the second segmented polynomial shaped shoulder oppose one another so as to be constantly diverging or converging from one another.

21. The internal combustion engine of claim 20, wherein a segment of the shoulder shape extending from a peak towards the second trough is linear, wherein the linear segment of shoulder shape extending from a lobe peak has a slope greater than zero and less than 20 degrees.

22. The internal combustion engine of claim 20, wherein the first and second segmented polynomial shaped shoulders are symmetric in shape extending from a respective lobe peak to a point along the descending shoulder portion and asymmetric in shape along the shoulders extending from the respective second trough to the lobe peak.

23. A method for operating an internal combustion engine comprising:

moving a first cam follower along a first cam from a first position on the first cam in which a first piston is at inner dead center within a combustion cylinder to a second position on the first cam in which the first piston blocks flow through an intake port in the cylinder, and simultaneously moving a second cam follower along a second cam from a first position on the second cam in which a second piston is at inner dead center within the combustion cylinder to a second position on the second cam, so as to cause the second piston to open an exhaust port in the cylinder, wherein the respective piston move axially away from one another as the respective cam followers move from the first position to the second position;

continuing to move the first cam follower along the first cam from the second position to a third position on the first cam so as to cause the first piston to continue to move away from inner dead center and to open the intake port, and simultaneously moving the second cam follower along the second cam from the second position to a third position so as to cause the second piston to move away from the first piston while the exhaust port remains open to outer dead center for the second piston;

continuing to move the first cam follower along the first cam from the third position to a fourth position in which the intake port remains open, and simultaneously moving the second cam follower along the second cam from the third position to a fourth position so as to cause the second piston to close the exhaust port in the cylinder, wherein the respective piston move axially towards one another as the respective cam followers move from the third position to the fourth position;

continuing to move the first cam follower along the first cam from the fourth position to a fifth position so as to cause the first piston to move axially towards second

66

piston and inner dead center, whereby movement of the first piston closes the intake port in the cylinder, and simultaneously moving the second cam follower along the second cam from the fourth position to a fifth position so as to cause the second piston to move axially towards the first piston and inner dead center; and

continuing to move the first cam follower along the first cam from the fifth position to the first position on the cam so as to cause the first piston to move axially towards second piston and inner dead center, and simultaneously moving the second cam follower along the second cam from the fifth position to the first position on the cam so as to cause the second piston to move axially towards the first piston and inner dead center.

24. The method of claim 23, wherein movement of the cam followers along their respective cams from the fourth position to the fifth position causes an inertial supercharging effect within the combustion chamber.

25. The method of claim 23, wherein movement of the cam followers along their respective cams from the second position to the third position initiates scavenging.

26. The method of claim 23, wherein movement of the cam followers along their respective cams from the third position to the fourth position causes uniflow scavenging.

27. The method of claim 23, wherein movement of the cam followers along their respective cams from the second position to the third position causes the Kadenacy effect within the combustion cylinder on combustion gases.

28. The method of claim 23, wherein the first and second pistons are in phase as the cam followers move along their respective cams from the first position to the second position, and the first and second pistons are out of phase as the cam followers move along their respective cams from the second position through the third, fourth and fifth positions back to the first position.

29. The method of claim 23, wherein the pistons are continually moving within the combustion cylinder during operation of the internal combustion engine.

30. The method of claim 23, wherein the pistons have a divergence rate as the cam followers move from the first position to the third position and a convergence rate as the cam followers move from the fourth position back to the first position, wherein the divergence rate of the pistons at the beginning of movement of the cam followers from the first position to the second position on their respective cams is uniform and occurs at a first divergence rate, and thereafter continued divergence of the pistons as movement of the cam followers continues from the first position to the second position on their respective cams is uniform and occurs at a second divergence rate higher than the first divergence rate.

\* \* \* \* \*