

- [54] **FERRITE MODE SUPPRESSOR FOR MAGNETRONS**
- [72] Inventors: **Robert E. Edwards**, Lexington; **John M. Osepchuk**, Concord, both of Mass.
- [73] Assignee: **The United States of America** as represented by the Secretary of the Navy
- [22] Filed: **Sept. 9, 1970**
- [21] Appl. No.: **70,707**
- [52] U.S. Cl. **315/39.51, 315/39.55, 315/39.77, 331/91, 333/98 M**
- [51] Int. Cl. **H01j 25/50**
- [58] Field of Search **315/5.21, 39.51, 39.55, 39.77; 331/91**

[56]		References Cited
UNITED STATES PATENTS		
3,333,148	7/1967	Buck.....315/39.55
3,334,267	8/1967	Plumridge.....315/39.55
2,941,115	6/1960	Meixner.....315/5.21
3,118,082	1/1964	Brunn.....315/5.21

Primary Examiner—Herman Karl Saalbach
Assistant Examiner—Saxfield Chatmon, Jr.
Attorney—R. S. Sciascia and H. H. Losche

[57] **ABSTRACT**
 A ferrite mode suppressor for magnetrons having a ferrite annular member affixed in a region of a magnetron cavity where the radiofrequency magnetic field of a competing mode is strong and where the radiofrequency magnetic field of the π -mode is weak to suppress or absorb the competing mode or modes.

4 Claims, 1 Drawing Figure

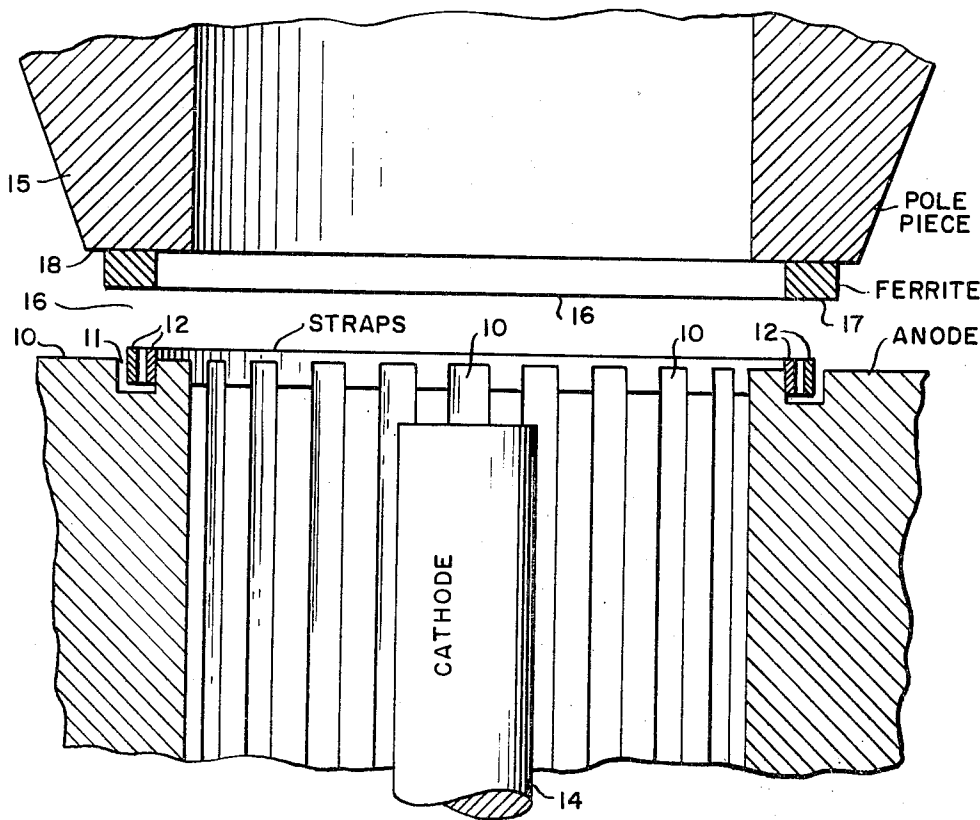

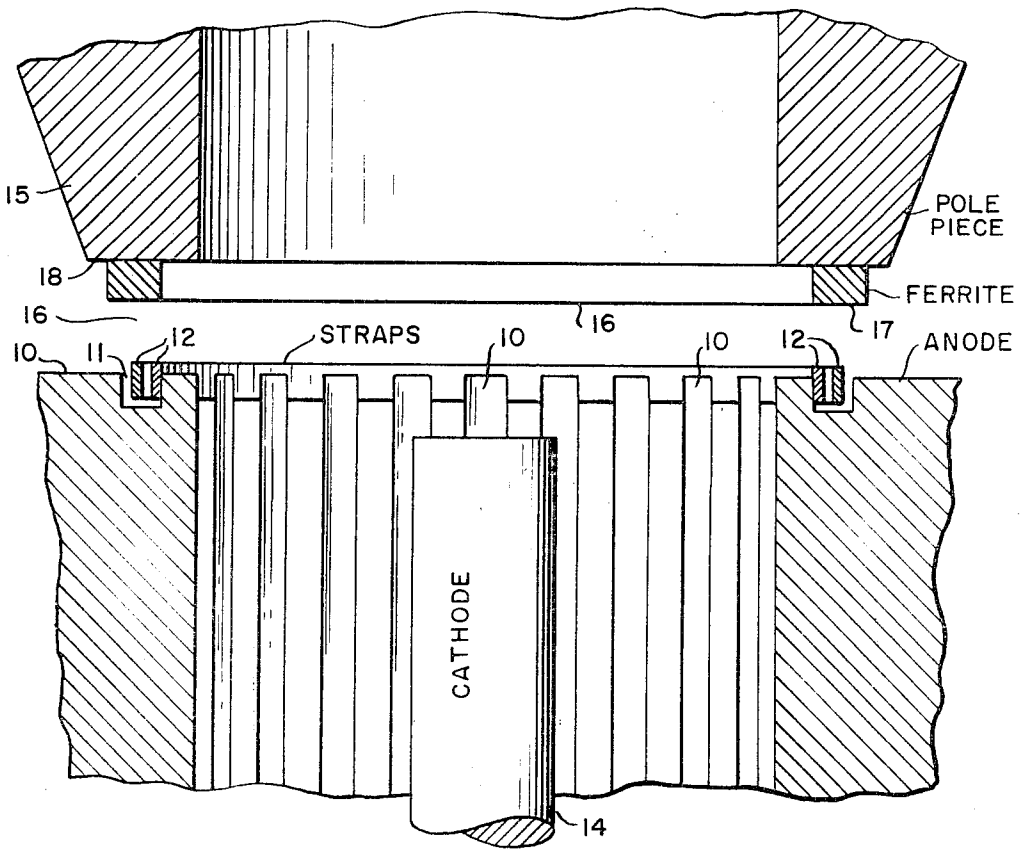

INVENTORS
ROBERT E. EDWARDS
JOHN M. OSEPCHUK
BY

H. H. Louch
ATTORNEYS

FERRITE MODE SUPPRESSOR FOR MAGNETRONS

BACKGROUND OF THE INVENTION

The invention relates to magnetron structures and more particularly to structural means of suppressing or absorbing the undesirable modes generated therein which compete with the desirable mode for transmission.

There are known means of suppressing undesirable modes in the prior art in which lossy materials are used in the resonator cavity, positioned on the wall of the cavity, positioned on the anode, or positioned in some cavity well. While these provide various degrees of suppression of undesirable modes, the lossy material should be at a location most effective to substantially absorb all unwanted modes of oscillation.

SUMMARY OF THE INVENTION

In this invention a ferrite material is used in suitable shapes and placed at a strategic place in the magnetron cavity to suppress or absorb modes of oscillation other than the π -mode. It has been found in this invention that the placement of a ring or annular member of ferrite material on a pole piece in the resonator chamber of a coaxial magnetron where the radiofrequency (RF) magnetic field of the undesirable or competing mode is strong and where the RF magnetic field of the π -mode is weak will cause absorption of the competing mode or modes. Such rings or annular ferrite members can be used in "rising sun" magnetrons as well as unstrapped or strapped magnetrons of conventional design. Such rings can also be used for magnetrons using interdigital structures. The design of the pole piece and interaction space must be such that when a suitable interaction field is obtained in the interaction space, then the field (DC magnetic) at the ferrite is such that ferromagnetic resonance occurs in the ferrite at the competing mode frequency or frequencies. The shape of the ferrite ring can be adjusted to some extent to yield the proper resonance frequency; that is, the resonant frequency depends on the demagnetizing factors which can be controlled somewhat by the shape of the sample through the use of Kittel's equation. It is accordingly an object of this invention to provide a magnetron with a ferrite absorber or suppressor to produce a strong π -mode frequency with minimized competing modes of oscillation for transmission.

BRIEF DESCRIPTION OF THE DRAWING

These and other objects and the attendant advantages, features and uses of the invention will become more apparent to those skilled in the art as a more detailed description proceeds when considered along with the accompanying drawing illustrating a partial sectional view of the cavity area of a magnetron.

DESCRIPTION OF THE PREFERRED EMBODIMENT

Referring more particularly to the FIGURE of drawing, the partial sectional view of a magnetron, is a section of the anode 10 having coupling slots therein to provide a plurality of anode vanes, shown therein. In the top annular portion of the anode 10 is an annular groove 11 for supporting magnetron straps 12 by affixing one strap to alternate anode vanes 10 and by affixing the other strap to the other alternate vanes 10, as well understood in the construction of strapped magnetrons by those skilled in the art. While the magnetron section shown therein is with a cathode 14 located on the axis of the anode 10, it is to be understood that the magnetron could be of the inverted type in which the cathode would be annularly positioned just above and outside the top surface of the anode 10. Positioned over the anode 10 is a pole piece 15 providing a resonator chamber 16 between the pole piece 15 and the anode 10. The pole piece is concentric with the axis of the anode.

In carrying out this invention of suppression or absorption of undesirable modes of oscillation, a ferrite ring or annular member 17 is braised or otherwise affixed to the bottom surface 18 of the pole piece 15 in the resonator chamber 16. This

ferrite ring 17 may be yttrium iron garnets, often referred to as "YIG," although other types of ferrite material may be used where desired and based on requirements for resonance and the ability to withstand tube braising and backout conditions. The ferrite ring is located so that effective coupling to the adjacent modes takes place without any substantial suppression or absorption of the desired π -mode. The spacing between the ferrite ring 17 and the straps 12 should be made sufficient for protection against arcing in the presence of high-peak RF voltages. The line width of the ferrite ring 17 can be chosen to adjust the width of suppression band in frequency to some extent. The dimension can be adjusted until an adequate loading of adjacent competing modes could be obtained at some B-field without serious loading of the π -mode. The ring would also be effective if located with a greater radius which should allow the magnetron to operate with a higher B-field in the resonator chamber for a condition of ferromagnetic resonance at the adjacent mode frequencies. This, however, is a matter of choice for the power and type of magnetron used. The basic elements are proper location of the ferromagnetic material 17 at a point of substantial RF magnetic field of the mode or modes which are to be suppressed. This can be determined to a great extent through the use of Kittel's equation or in any case by probing experiments. Magnetic shims may be useful in some cases in order to adjust the value of direct current magnetic field at the ferrite suppressor element 17. In general, the ferrite material 17 is best placed in a region where the RF magnetic field of the competing mode or modes are strong and preferably, though not necessarily, where the RF magnetic field of the π -mode is weak. The advantages gained are less spurious content in the spectrum and increased stability of operation.

OPERATION

In the operation of the magnetron using this ferrite material, oscillations are produced in the magnetron predominately of the desirable π -mode along with other undesirable modes which need suppression or absorption. Some latitude is provided in the control of the direct current magnetic field produced through the pole piece 15 in the resonator chamber 16 such that ferromagnetic resonance occurs in the ferrite material 17 of the competing mode frequency or frequencies. It was found that by proper adjustment of the direct current magnetic field to provide the greatest ferromagnetic resonance at the adjacent mode frequencies the competing modes were decreased by 24 db. with the use of the ferrite material 17. The tendency to mode under abnormal conditions, such as zero heater power, was substantially suppressed when the ferrite ring 17 was tuned to resonance. No deleterious effects, such as gas or cathode poisoning, appears to be observed with the magnetron tube incorporating the ferrite ring although operation up to 100-kilowatt peak and 100 watts average may be obtained with good efficiency.

While other modifications and advantages may be realized with the adaptation of the ferrite ring, such as 17, to different types of magnetrons, as coaxial magnetrons, inverted magnetrons, rising sun magnetrons, as well as strapped and unstrapped magnetrons, without departing from the spirit of this invention, we desire to be limited only by the scope of the appended claims.

We claim:

1. A ferrite mode suppressor means for magnetrons comprising:

a magnetron having an annular anode, a cathode, and an annular pole piece overlying the annular anode providing a resonator chamber between the anode and pole piece; and

a ferrite annular member affixed to said annular pole piece in said resonator chamber where the radiofrequency magnetic field of the undesirable and competing modes are strong and the radiofrequency field of the π -mode is weak during operation whereby said ferrite annular member

3

4

absorbs the radio frequency of undesirable competing modes of oscillation.

said anode is strapped and said ferrite annular member overlies said straps.

2. A ferrite mode suppressor means as set forth in claim 1 wherein

4. A ferrite mode suppressor means as set forth in claim 1 wherein

said ferrite annular member is of yttrium iron garnets.

3. A ferrite mode suppressor means as set forth in claim 2 wherein

said magnetron is a coaxial magnetron.

* * * * *

10

15

20

25

30

35

40

45

50

55

60

65

70

75