



- (51) International Patent Classification:
A61C 7/08 (2006.01) A61C 9/00 (2006.01)
A61C 7/00 (2006.01)
- (21) International Application Number:
PCT/IB2018/057159
- (22) International Filing Date:
18 September 2018 (18.09.2018)
- (25) Filing Language: English
- (26) Publication Language: English
- (30) Priority Data:
62/568,982 06 October 2017 (06.10.2017) US
- (71) Applicant: **3M INNOVATIVE PROPERTIES COMPANY** [US/US]; 3M Center, Post Office Box 33427, Saint Paul, Minnesota 55133-3427 (US).
- (72) Inventors: **RABY, Richard E.**; 3M Center, Post Office Box 33427, Saint Paul, Minnesota 55133-3427 (US), **LI,**

Chaodi; 3M Center, Post Office Box 33427, Saint Paul, Minnesota 55133-3427 (US), **DOMROESE, Michael K.**; 3M Center, Post Office Box 33427, Saint Paul, Minnesota 55133-3427 (US).

(74) Agent: **VIETZKE, Lance L.**, et al.; 3M Center, Office of Intellectual Property Counsel, Post Office Box 33427, Saint Paul, Minnesota 55133-3427 (US).

(81) Designated States (unless otherwise indicated, for every kind of national protection available): AE, AG, AL, AM, AO, AT, AU, AZ, BA, BB, BG, BH, BN, BR, BW, BY, BZ, CA, CH, CL, CN, CO, CR, CU, CZ, DE, DJ, DK, DM, DO, DZ, EC, EE, EG, ES, FI, GB, GD, GE, GH, GM, GT, HN, HR, HU, ID, IL, IN, IR, IS, JO, JP, KE, KG, KH, KN, KP, KR, KW, KZ, LA, LC, LK, LR, LS, LU, LY, MA, MD, ME, MG, MK, MN, MW, MX, MY, MZ, NA, NG, NI, NO, NZ, OM, PA, PE, PG, PH, PL, PT, QA, RO, RS, RU, RW, SA, SC, SD, SE, SG, SK, SL, SM, ST, SV, SY, TH, TJ, TM, TN, TR, TT, TZ, UA, UG, US, UZ, VC, VN, ZA, ZM, ZW.

(54) Title: REMOVABLE DENTAL APPLIANCE INCLUDING SPRING BELLOWS

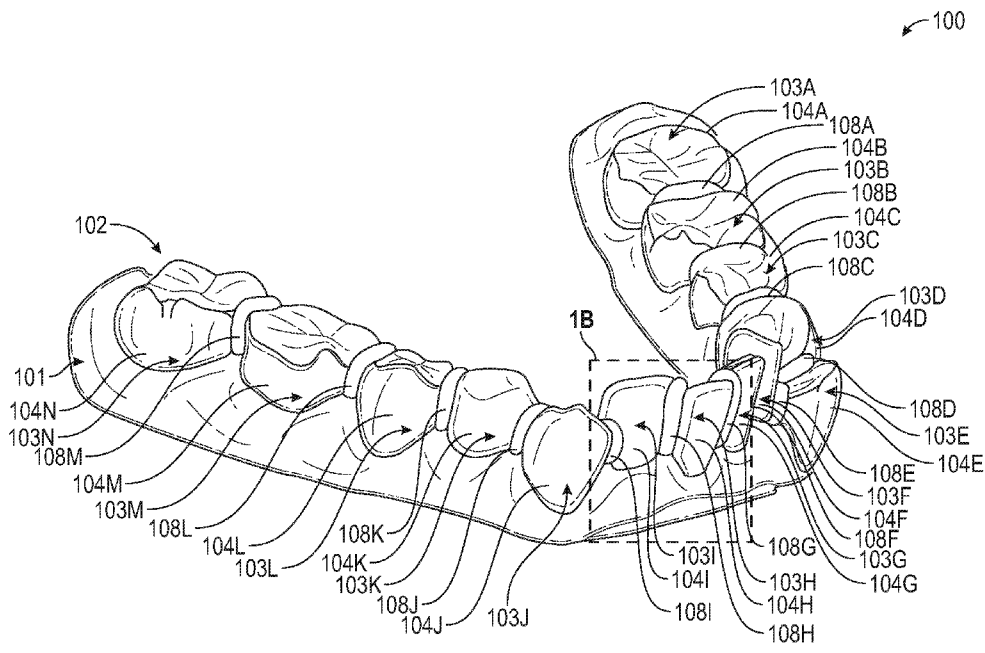

FIG. 1A

(57) Abstract: A removable dental appliance may include an appliance body at least partially surrounding two or more teeth of a patient. The appliance body may include a first shell shaped to receive a first tooth; a second shell shaped to receive a second tooth; and at least one spring bellows that includes an arcuate displacement extending over and away from at least a portion of an interproximal region between the first tooth and the second tooth to join the first shell and the second shell. The spring bellows is configured to apply a force between the first shell and the second shell to cause movement of at least one of the first tooth and the second tooth toward a desired position when the removable dental appliance is worn by the patient.



(84) Designated States (*unless otherwise indicated, for every kind of regional protection available*): ARIPO (BW, GH, GM, KE, LR, LS, MW, MZ, NA, RW, SD, SL, ST, SZ, TZ, UG, ZM, ZW), Eurasian (AM, AZ, BY, KG, KZ, RU, TJ, TM), European (AL, AT, BE, BG, CH, CY, CZ, DE, DK, EE, ES, FI, FR, GB, GR, HR, HU, IE, IS, IT, LT, LU, LV, MC, MK, MT, NL, NO, PL, PT, RO, RS, SE, SI, SK, SM, TR), OAPI (BF, BJ, CF, CG, CI, CM, GA, GN, GQ, GW, KM, ML, MR, NE, SN, TD, TG).

Declarations under Rule 4.17:

- *as to applicant's entitlement to apply for and be granted a patent (Rule 4.17(ii))*
- *as to the applicant's entitlement to claim the priority of the earlier application (Rule 4.17(iii))*

Published:

- *with international search report (Art. 21(3))*
- *before the expiration of the time limit for amending the claims and to be republished in the event of receipt of amendments (Rule 48.2(h))*
- *in black and white; the international application as filed contained color or greyscale and is available for download from PATENTSCOPE*

REMOVABLE DENTAL APPLIANCE INCLUDING SPRING BELLOWS

5

TECHNICAL FIELD

[0001] This disclosure relates to polymer-based removable dental appliances such as tooth aligners.

BACKGROUND

10

[0002] The field of orthodontics relates to repositioning a patient's teeth for improved function and aesthetic appearance. Orthodontic devices and treatment methods generally involve the application of forces to move teeth into a proper bite configuration, or occlusion. As one example, orthodontic treatment may involve the use of slotted appliances, known as brackets, which are fixed to the patient's anterior, cuspid, and bicuspid teeth. An archwire is typically placed in the slot of each bracket and serves as a track to guide movement of the teeth to desired orientations. The ends of the archwire are usually received in appliances known as buccal tubes that are secured to the patient's molar teeth. Such dental appliances remain in the mouth of the patient and are periodically adjusted by an orthodontist to check the process and maintain the proper force on the teeth until proper alignment is achieved.

15

20

[0003] Orthodontic treatment may also involve the use of alignment trays, such as clear or transparent, polymer-based tooth positioning trays, often referred to as clear tray aligners (CTAs). For example, orthodontic treatment with CTAs may include forming a tray having shells that engage one or more teeth. Each shell may be deformed from an initial position of a tooth, e.g., a malocclusion position. The deformed position of a respective shell of the CTA may apply a force to a respective tooth toward a desired position for the tooth that is an intermediate position between the initial position and a final position resulting from the orthodontic treatment.

25

SUMMARY

30

[0004] In some examples, the disclosure describes a removable dental appliance including an appliance body configured to at least partially surround two or more teeth of a patient. The appliance body includes a first shell shaped to receive a first tooth of the patient; a second shell shaped to receive a second tooth of the patient; and at least one spring bellows. The at

least one spring bellows includes an arcuate displacement of the appliance body extending over and away from at least a portion of an interproximal region between the first tooth and the second tooth to join the first shell and the second shell. The at least one spring bellows is configured to apply a force between the first shell and the second shell to cause movement of
5 at least one of the first tooth and the second tooth toward a desired position when the removable dental appliance is worn by the patient.

[0005] In some examples, the disclosure describes a system that includes an ordered set of removable dental appliances configured to reposition one or more teeth of a patient. Each removable dental appliance in the set of removable dental appliances includes an appliance
10 body configured to at least partially surround two or more teeth of the patient. The appliance body includes a first shell shaped to receive a first tooth of the patient; a second shell shaped to receive a second tooth of the patient; and at least one spring bellows. The at least one spring bellows includes an arcuate displacement of the appliance body extending over and away from at least a portion of an interproximal region between the first tooth and the second
15 tooth to join the first shell and the second shell. The at least one spring bellows is configured to apply a force between the first shell and the second shell to cause movement of at least one of the first tooth and the second tooth toward a desired position when the removable dental appliance is worn by the patient.

[0006] In some examples, the disclosure describes a method that includes forming a model of
20 dental anatomy of a patient; and forming, based on the model, a removable dental appliance. The removable dental appliance includes an appliance body configured to at least partially surround two or more teeth of the patient. The appliance body includes a first shell shaped to receive a first tooth of the patient; a second shell shaped to receive a second tooth of the patient; and at least one spring bellows. The at least one spring bellows includes an arcuate
25 displacement of the appliance body extending over and away from at least a portion of an interproximal region between the first tooth and the second tooth to join the first shell and the second shell. The at least one spring bellows is configured to apply a force between the first shell and the second shell to cause movement of at least one of the first tooth and the second tooth toward a desired position when the removable dental appliance is worn by the patient.

[0007] In some examples, the disclosure describes a method that includes receiving, by a
30 computing device, a digital representation of a three-dimensional (3D) dental anatomy of a patient providing initial positions of one or more teeth of the patient. The method also includes determining, by the computing device, dimensions and shapes of a removable dental appliance for the patient. The removable dental appliance includes an appliance body

configured to at least partially surround two or more teeth of the patient. The dimensions and shapes of the removable dental appliance are configured to reposition the one or more teeth of the patient from initial positions to desired positions when the removable dental appliance is worn by the patient. The dimensions and shapes of the removable dental appliance include positions, dimensions, and shapes of at least one of a first shell shaped to receive a first tooth of the patient; a second shell shaped to receive a second tooth of the patient; and at least one spring bellows. The at least one spring bellows includes an arcuate displacement of the appliance body extending over and away from at least a portion of an interproximal region between the first tooth and the second tooth to join the first shell and the second shell. The at least one spring bellows is configured to apply a force between the first shell and the second shell to cause movement of at least one of the first tooth and the second tooth toward a desired position when the removable dental appliance is worn by the patient. The method also includes transmitting, by the computing device, a representation of the removable dental appliance to a computer-aided manufacturing system.

[0008] In some examples, the disclosure describes a non-transitory computer-readable storage medium that stores computer system-executable instructions that, when executed, configure a processor to receive, by a computing device, a digital representation of a three-dimensional (3D) dental anatomy of a patient providing initial positions of one or more teeth of the patient. The non-transitory computer-readable storage medium also stores computer system-executable instructions that, when executed, configure a processor to determine, by the computing device, dimensions and shapes of a removable dental appliance for the patient. The removable dental appliance includes an appliance body configured to at least partially surround two or more teeth of the patient. The dimensions and shapes of the removable dental appliance are configured to reposition the one or more teeth of the patient from initial positions to desired positions when the removable dental appliance is worn by the patient. The dimensions and shapes of the removable dental appliance include positions, dimensions, and shapes of at least one of a first shell shaped to receive a first tooth of the patient; a second shell shaped to receive a second tooth of the patient; and at least one spring bellows. The at least one spring bellows includes an arcuate displacement of the appliance body extending over and away from at least a portion of an interproximal region between the first tooth and the second tooth to join the first shell and the second shell. The at least one spring bellows is configured to apply a force between the first shell and the second shell to cause movement of at least one of the first tooth and the second tooth toward a desired position when the removable dental appliance is worn by the patient. The non-transitory computer-readable

storage medium also stores computer system-executable instructions that, when executed, configure a processor to transmit, by the computing device, a representation of the removable dental appliance to a computer-aided manufacturing system.

[0009] The details of one or more examples of this disclosure are set forth in the accompanying drawings and the description below. Other features, objects, and advantages of this disclosure will be apparent from the description and drawings, and from the claims.

BRIEF DESCRIPTION OF THE DRAWINGS

[0010] FIGS. 1A and 1B illustrate an oblique view of an example removable dental appliance that includes a plurality of spring bellows configured to apply forces to cause movement of the teeth of a patient toward a desired position.

[0011] FIGS. 2A–2I illustrate different views of an example removable dental appliance that includes a plurality of spring bellows.

[0012] FIGS. 3A and 3B illustrate different views of an example removable dental appliance that includes a plurality of spring bellows and shear reduction regions.

[0013] FIG. 4 illustrates an occlusal view of an example removable dental appliance that includes a plurality of spring bellows extending around the respective gingival margin of each respective shell.

[0014] FIG. 5 is a block diagram illustrating an example computer environment in which a clinic and manufacturing facility communicate information throughout a dental appliance manufacturing process.

[0015] FIG. 6 is a flow diagram illustrating an example process of generating digital dental anatomy data.

[0016] FIG. 7 is a block diagram illustrating an example of a client computing device connected to a manufacturing facility via a network to generate digital dental anatomy data.

[0017] FIG. 8 is a block diagram illustrating an example computer-aided manufacturing system for construction of a removable dental appliance.

[0018] FIG. 9 is a flow diagram illustrating a process conducted at a manufacturing facility for construction of a set of removable dental appliances that include spring bellows.

[0019] FIG. 10 is a flow diagram illustrating successive iterations of treatment using an ordered set of removable dental appliances that include spring bellows.

[0020] FIGS. 11A and 11B illustrate a directional deformation diagram and an equivalent stress diagram for a modeled removable dental appliance that does not include spring bellows.

[0021] FIGS. 12A and 12B illustrate a directional deformation diagram and an equivalent stress diagram for a modeled removable dental appliance that includes spring bellows.

[0022] FIGS. 13A and 13B illustrate a directional deformation diagram and an equivalent stress diagram for a modeled removable dental appliance that includes spring bellows and shear reduction regions.

DETAILED DESCRIPTION

[0023] This disclosure describes removable dental appliances that include at least one spring bellows. Orthodontic treatment with the removable dental appliances described in this disclosure may include the use of at least one spring bellows between adjacent shells to enable greater control of force vectors and directional magnitudes applied to the teeth of the patient. A spring bellows may extend over an interproximal region between a first tooth and a second tooth to join adjacent shells, e.g., a first shell and a second shell that receive the first tooth and the second tooth, respectively. During use of the removable dental appliance, insertion of the removable dental appliance in the mouth of a patient may result in at least some of the removable dental appliance being deformed, e.g., from a physical configuration in which the removable dental appliance was formed to a configuration in which teeth of the patient are received in shells of the removable dental appliance. The deformation of the removable dental appliance may be concentrated in the spring bellows. For example, the spring bellows may deform more than the first shell, the second shell, or both. The deformation may result in a force being created in the spring bellows, such as, for example, compression, tension, shear, bending, or torsion forces. The force may be a restorative force causing the spring bellows to urge the first shell, the second shell, or both in one or more directions that would result in the spring bellows becoming less deformed. The force on the shells may result in force vectors on one or more teeth of the patient. In this way, the removable dental appliance including spring bellows may be configured to apply a force to move the teeth of a patient.

[0024] By concentrating the deformation of the removable dental appliance in the spring bellows, a respective shell may remain more highly engaged with a respective tooth, e.g., such that more points of the respective shell contacts a respective tooth, a greater surface area of the respective shells contacts a respective tooth, or the like, when the removable dental appliance is worn by the patient, compared to removable dental appliances without a spring bellows. For example, a respective shell of a removable dental appliance without spring

bellows both engages a respective tooth and creates the force required to move the tooth during the course of orthodontic treatment. However, the degree of tooth engagement (e.g., the amount and positions of shell/tooth contact) may affect control of the force applied to the tooth. For example, a removable dental appliance without spring bellows may provide
5 reduced control compared to a removable dental appliance with spring bellows due to adverse (e.g., undesirable or indeterminate) deformation of the shells that may result in indeterminate engagement of the shells and teeth. The undesired deformation of the shells and indeterminate engagement of the shells and teeth may result in forces being applied to the teeth in one or more indeterminate directions with indeterminate magnitudes. By decoupling
10 engagement of teeth from application of the force to the teeth, the disclosed removable dental appliance improves engagement of teeth in the shells by reducing adverse deformation of the shells and concentrates deformation in the spring bellows without resulting in unpredictable contact points on the teeth. In this way, by separating the force generating member (the spring bellows) and the engagement member (the shells), the removable dental appliances
15 may allow greater control of forces applied to teeth.

[0025] In some examples, the spring bellows may be configured to control the magnitude, direction, and length of expression of the force applied to a respective shell and the resulting force applied to the respective tooth. For example, the spring bellows may be positioned and shaped to provide a selected force in a selected direction to at least one shell. The force on
20 the respective shell may result in a desired force vector on the respective tooth. For example, the force vector may be applied to the shell in a direction, a magnitude, or both that may not be possible to apply to the shell without the spring bellows. Likewise, the force vector may be applied to the shell with a degree of certainty that might not be possible otherwise. The spring bellows may also enable expression of a force over a greater distance. For example,
25 arcuate displacement of the spring bellows may be longer than an interproximal region between adjacent teeth. The length of the arcuate displacement may allow the spring bellows to express a force as the arcuate displacement extends, recoils, or otherwise reacts to at least one of a compression, tension, shear, bending, or torsion. The force may be expressed until the arcuate displacement reacts to the extent that the stored compression, tension, shear,
30 bending, or torsion is insufficient to move the teeth. For example, movement of a tooth may cease when the force resulting from the compression, tension, shear, bending, or torsion in the spring bellows is less than a force necessary to result in alveolar bone remodeling. In this way, the removable dental appliance may improve control of at least one of force vector direction, magnitude, or expression length, to achieve at least one of a desired tooth

movement that may not be possible without spring bellows, a desired tooth movement over a shortened treatment time, a desired tooth movement with fewer progressions of removable dental appliances in a set of removable dental appliances, or the like, compared to other orthodontic treatments.

5 **[0026]** FIGS. 1A and 1B illustrate an oblique facial view of an example removable dental appliance 100 engaged with teeth 103A–103N (collectively, “teeth 103”) of the mandibular arch 101 of a patient. The number of teeth 103 may be less than fourteen, e.g., a patient having one or more extracted teeth, or more than fourteen, e.g., a patient having wisdom teeth or hyperdontia. Removable dental appliance 100 may include an aligner tray. For example,
10 removable dental appliance 100 includes an appliance body 102 including a plurality of shells 104A–104N (collectively, “shells 104”) and a plurality of spring bellows 108A–108M (collectively, “spring bellows 108”). For purposes of illustration, only a first shell 104H, a second shell 104I, and a (single) spring bellows 108H are labeled in FIG. 1B, although appliance body 102 defines fourteen shells (one for each tooth) and thirteen spring bellows
15 (one spring bellows between each pair of adjacent shells). For example, spring bellows 108 may be configured to apply a force between two respective shells of shells 104 to cause movement of at least one respective tooth of teeth 103 toward a desired position. For example, spring bellows 108H may be configured to apply a force between first and second shells 104H and 104I to cause movement of at least one of first and second tooth 103H and
20 103I toward a desired position. In this way, removable dental appliance 100 may improve control of at least one of force vector direction, magnitude, or expression length, to achieve at least one of a desired tooth movement that may not be possible without spring bellows 108, a desired tooth movement over a shortened treatment time, a desired tooth movement with fewer progressions of removable dental appliances in a set of removable dental appliances, or
25 the like, compared to other orthodontic treatments.

[0027] Appliance body 102 may be configured to at least partially surround two or more teeth 103 of either the maxillary dental arch or, as shown in FIG. 1, the mandibular dental arch 101 of a patient. For example, appliance body 102 may surround at least one of the facial, lingual, and occlusal surfaces of teeth 103, overlap a portion of the gingiva of the
30 patient, or the like. In some examples, appliance body 102 may surround different portions of different teeth 103.

[0028] Appliance body 102 includes shells 104, and each respective shell of shells 104 is shaped to receive at least one respective tooth of teeth 103. For example, a respective shell of shells 104 may be shaped to contact at least one selected location, a selected surface area, or

both of a respective tooth of teeth 103. For example, first shell 104H may be shaped to receive first tooth 103H and second shell 104I shaped to receive second tooth 103I. In some examples, appliance body 102 may define a respective shell of shells 104 for each respective tooth of teeth 103. In other examples, appliance body 102 may define fewer shells than teeth, e.g., a shell may receive more than one tooth or at least one of teeth 103 may not be surrounded by a shell of shells 104. In other examples, appliance body 102 may define more shells 104 than teeth 103, e.g., two or more shells or shell-like portions may surround at least a portion of at least one tooth or a shell in place to receive an unerupted tooth.

[0029] In some examples, shells 104 may surround the facial, lingual, and occlusal portions of teeth 103. In other examples, shells 104 may surround fewer portions of teeth 103, such as, for example, only the facial and lingual portions, or only one or the facial or lingual portions of teeth 103. By selecting the shape of a respective shell of shells 104, removable dental appliance 101 may control the locations of a force applied to a respective tooth of teeth 103. In some examples, a thickness of a respective shell of shells 104 may range between about 0.10 millimeters and about 2.0 millimeters, such as between about 0.2 and about 1.0 millimeters, or between 0.30 millimeters and 0.75 millimeters.

[0030] Appliance body 102 may include one or more anchor shells configured to receive one or more anchor teeth. In some examples, anchor teeth may include one or more molar teeth, premolar teeth, or both, such as, for example, teeth 103A–103D and 103K–103N, and anchor shells may include corresponding shells, such as, for example, shells 104A–104D and 104K–104N. In other examples, anchor teeth may include one or more anterior teeth, or a combination of one or more anterior and posterior teeth. Anchor shells may be configured to allow portions of appliance body 102 to deform to result in a force sufficient to move one or more teeth (e.g., force sufficient to cause alveolar bone remodeling) without resulting in sufficient force to move the respective anchor teeth. For example, anchor shells 104A–104D and 104K–104N may be coupled to one or more adjacent shells directly, without spring bellows (not shown in FIGS. 1A and 1B). In other examples, as shown in FIGS. 1A and 1B, appliance body 102 may omit any one or more of anchor shells 104A–104D and 104K–104N.

[0031] Appliance body 102 includes at least one spring bellows 108. In general, a respective spring bellows of spring bellows 108 may be positioned between respective adjacent shells 104. Removable dental appliance 100 may be formed with a physical configuration so that an undeformed removable dental appliance 100 has a shape corresponding to an intermediate or a desired position of teeth 103, such that the shape of removable dental appliance 100 is different than a current position of teeth 103. When removable dental appliance 100 is worn

by the patient, appliance body 102 may deform to allow shells 104 to receive teeth 103. The deformation of appliance body 102 may result in deformation of spring bellows 108, which may induce a force, such as at least one of compression, tension, shear, bending, and torsion, in one or more portions of spring bellows 108. The force in spring bellows 108H may be transferred to first shell 104H, second shell 104I, or both. Shells 104H and 104I may be engaged with teeth 103H and 103I, and cause the force to be transferred to teeth 103H and 103I. In this way, deformation of appliance body 102 may transfer a force, via spring bellows 108 and shells 104, to the teeth 103.

[0032] The direction of the force on a respective tooth of teeth 103 may result in part from one or more locations of engagement of at least one surface of a respective shell of shells 104 with at least one surface of the respective tooth of teeth 103 and attachment points of spring bellows 108 to shells 104. In some examples, the number of locations of engagement, the total area of engagement, or both of the respective shell of shells 104 with the respective tooth of teeth 103 may be greater than the number of locations of engagement, the total area of engagement, or both of a removable dental appliance without spring bellows. For example, a force applied by a spring bellows of spring bellows 108 may be concentrated at the attachment point of the spring bellows to the shell. Thus, the direction of the applied force to a tooth of teeth 103 may be selected by selecting an attachment point of one or more spring bellows of spring bellows 108 to the shell of shells 104 that engages the tooth.

[0033] For example, a force distributed substantially evenly across the facial surface of the tooth may cause a translation of the tooth in the lingual direction. Hence, to achieve a translation of a tooth, the attachment points of the spring bellows that attach to the shell that engages the tooth may be selected to distribute force substantially evenly across the facial surface of the tooth. A force concentrated on a mesial half of a facial surface of a tooth, or one half of a facial surface and the opposite half of the lingual surface of the tooth, may cause a rotation of the tooth in the lingual direction about an axis of rotation extending generally in the occlusal-lingual direction. Hence, to achieve a rotation of a tooth, the attachment points of the spring bellows that attach to the shell that engages the tooth may be selected to distribute force on one half of a facial surface of the tooth or one half of the facial surface and the opposite half of the lingual surface of the tooth. A force concentrated on an occlusal surface (or occlusal to the height of curvature) of a tooth may cause an intrusion of the tooth. A force concentrated near a gingival margin (or gingival to the height of curvature) of a tooth may cause an extrusion of the tooth. A force concentrated on a portion of both the facial and occlusal surfaces of a tooth may cause a crown tipping of the tooth in the lingual-lingual

direction. A combination of a force concentrated at a facial-occlusal surface of a tooth and a force concentrated at a lingual-gingival surface of a tooth may cause a torqueing of the tooth with the crown moving in the occlusal direction and the root moving in the facial direction.

Other force vectors and combinations of force vectors that may result in one or more tooth movements are contemplated. In this manner, by selecting attachment points of spring bellows 108 to shells 104, removable dental appliance 100 may be configured to apply, via deformation of spring bellows 108, a force with a particular direction and magnitude to teeth 103 that may result in any one or more of a corresponding rotational, translational, extrusive, intrusive, tipping, or torqueing force to teeth 103.

5 [0034] Spring bellows 108, e.g., spring bellows 108H, may include an arcuate displacement of appliance body 102 extending over and away from at least a portion of an interproximal region, e.g., interproximal region 107H, between first and second teeth 103, e.g., first tooth 103H and second tooth 103I, to join first shell 104H and second shell 104I. The arcuate displacement may include a continuous or discontinuous curvilinear portion of appliance body 102, e.g., a half wave shape or a full wave shape. A half wave may include one half of a period of a full wave. A full wave fold may include one or more periods. In some examples, the arcuate displacement may include one fold, e.g., a half wave, or more than one fold, e.g., a full wave or a plurality of adjacent half waves. Including at least one fold in the arcuate displacement of spring bellows 108 may increase the length of the arcuate displacement between the positions where spring bellows 108 joins a respective first and second shells or shells 104. Increasing the length of the arcuate displacement may increase the flexibility of spring bellows 108. Increasing the flexibility due to increased arc length may allow spring bellows 108 to be formed of a material of a relatively higher modulus of elasticity than a less flexible spring bellows 108 due decreased arc length. Forming spring bellow 108 from a material of a higher modulus of elasticity may increase the durability of removable dental appliance 100, improve control of direction of the force applied to shells 104, or both. In other examples, the arcuate displacement may be a zigzag having two or more linear segments joined at an angle. Forming spring bellows 108 with curving shapes, for example of a zigzag shape, may result in more controllable and appropriate engaged force level and direction during tooth treatment interval.

10 [0035] The length of the arcuate displacement may be greater than a length of an interproximal surface extending between first intersection 110H of first shell 104H and spring bellows 108H and second intersection 112H of second shell 104I and spring bellows 108H. Additionally, the length of the arcuate displacement may be may be greater than an inward

displacement (extending over and toward at least a portion of the interproximal region 107H) traversing the interproximal region. When the length of the arcuate displacement is greater than the length of the interproximal surface, an inward displacement, or both, the arcuate displacement of spring bellows 108H may bend or otherwise deform when first and second shells 104H and 104I engage respective teeth 103H and 103I, when removable dental appliance 100 is inserted to be worn by the patient. The length of the arcuate displacement may affect the amount that spring bellows 108H deforms and the resulting force on first and second shells 104H and 104I from deformation. For example, a longer arcuate displacement may result in greater deformation of spring bellows 108H, and the greater deformation may result in a greater force in spring bellows 108H, a longer distance of expression of the force in spring bellows 108H, or both, compared to a lesser deformation of a shorter arcuate displacement of spring bellows 108H. In this way, the length of the arcuate displacement of a respective spring bellows of spring bellows 108 may affect the force resulting from the deformation of the respective spring bellows of spring bellows 108 when removable dental appliance 100 is worn by the patient.

[0036] In examples in which the arcuate displacement includes a continuous curve, the arcuate displacement may define an outer radius of curvature. The outer radius of curvature of the arcuate displacement may be affected by a length of the respective spring bellows of spring bellows 108 and the respective attachment points of the spring bellows to respective shells of shells 104. The outer radius of curvature is defined at an outermost surface of the spring bellows, e.g., a facial-most surface of a facially-oriented portion of the removable dental appliance 100, or a lingual-most surface a lingually-oriented surface of the removable dental appliance 100, respectively. In some examples, the outer radius of curvature may be between about 0.5 millimeters and about 2 millimeters, or about 0.75 millimeters and about 1.5 millimeters, or about 1.0 millimeters. The radius of curvature may be substantially constant or may vary along an interproximal boundary curve. For example, a substantially constant radius of curvature may cause a substantially even force in spring bellows 108H along the interproximal boundary curve. Conversely, a variable radius of curvature may concentrate the force from deformation in one or more portions of spring bellows 108H. For example, portions of spring bellows 108H where the radius of curvature is smaller (e.g., more curved) may enable greater localized stress and, thereby, more force concentration, in the portion of spring bellows 108H where the radius of curvature is smaller, compared to portions of spring bellows 108H where the radius of curvature is larger (e.g., less curved).

[0037] The arcuate displacement may define a displacement distance extending between a midline of the interproximal surface and a midline of the arcuate displacement (e.g., a magnitude of a half wave shape of the respective spring bellows). In some examples, the displacement distance may be less than about 2 millimeters, or less than about 1 millimeter, or less than about 0.75 millimeters, or about 0.5 millimeters. The displacement distance may be substantially constant or may vary along an interproximal boundary curve. For example, a substantially constant displacement distance may cause a substantially even force in spring bellows 108H along the interproximal boundary curve. Conversely, a variable displacement distance may concentrate more force in one or more portions of spring bellows 108H where the displacement distance is larger compared to portions of spring bellows 108H where the displacement distance is smaller. By selecting the shape, length, radius of curvature, and displacement distance of the arcuate displacement of a respective spring bellows of spring bellows 108, removable dental appliance 100 may control at least one of a direction, a magnitude, and a length of expression of a force on a respective shell of shells 104 resulting from deformation of appliance body 102 when removable dental appliance 100 is worn by the patient.

[0038] A respective terminal edge of a respective spring bellows of spring bellows 108 may couple to a respective terminal edge, or another surface, of a respective shell of shells 104. For example, as shown in FIG. 1B, a first respective terminal end of spring bellows 108H is coupled to a respective terminal edge of first shell 104H at first intersection 110H. Similarly, a second respective terminal end of spring bellows 108H is coupled to a respective terminal edge of second shell 104I at second intersection 112H. The location of the first and second intersections 110H and 112H may affect the direction of the force applied by spring bellows 108H to teeth 103H and 103I, via engaged shells 104H and 104I. For example, in examples in which spring bellows 108H and first shell 104H are coupled at respective terminal edges, the force may be transferred from spring bellows 108H to a mesial edge of first tooth 103H that is engaged with a mesial edge of first shell 104H. Force transfer via engagement near the edge of the respective tooth of teeth may enable or improve desired tooth movements such as rotations, torqueing, tipping, intrusions, or extrusions. The thickness of a respective shell of shells 104 may be increased near a coupling with a respective spring bellows of spring bellows 108 to reduce adverse deformation of the respective shell of shells 104 by the force exerted by the respective spring bellows of spring bellows 108. In examples in which a respective spring bellows of spring bellows 108 and a respective shell of shells 104 are coupled near the center of the respective shell of shells 104, the force may be transferred

from the respective spring bellows of spring bellows 108 to the center of a respective tooth of teeth 103 that is engaged with the respective shell of shells 104. Force transfer via engagement near the center of the respective tooth of teeth 103 may enable or improve desired tooth movements such as translations. In this way, the direction of the force from spring bellows 108 to teeth 103, via engaged shells 104, may be controlled.

[0039] The thickness of spring bellows 108 along the interproximal boundary curve or across the arcuate displacement may also be selected to control the magnitude and direction of the force resulting from deformation of spring bellows 108 when removable dental appliance 100 is worn by the patient. For example, a thickness of spring bellows 108 may be less than a thickness of first shell 104 and a thickness of second shell 106 such that spring bellows 108 deforms more than first shell 104 and second shell 106 to concentrate compression, tension, shear, bending, or torsion in spring bellows 108. The thickness of spring bellows 108 may be between about 0.025 millimeters and about 1.0 millimeter, or between about 0.1 millimeters and about 0.75 millimeters, or between about 0.15 and about 0.6 millimeters, or about 0.3 millimeters.

[0040] The thickness of spring bellows 108 may be substantially constant along the interproximal boundary curve or vary along the interproximal boundary curve to concentrate in spring bellows 108 the force resulting from a deformation of appliance body 102. For example, a respective spring bellows of spring bellows 108 may be relatively thicker near the cervical margin or gingival margin compared to near the occlusal surface. The relatively thicker portions of the respective spring bellows of spring bellows 108 may result in a greater force near the cervical margin or gingival margin compared to the occlusal portions to concentrate force near the cervical margin or gingival margin. By selecting a thickness of spring bellows 108 to concentrating the force in spring bellows 108 or in selected portions of spring bellows 108, removable dental appliance 100, when worn by the patient, may reduce deformation of shells 104 and increase engagement of shells 104 with teeth 103.

[0041] In some examples, spring bellows 108 may extend along an interproximal boundary curve extending from a facial-gingival position (e.g., where the facial side of the interproximal region meets the gingiva), over the occlusal plane of the dental arch, to a lingual-gingival position (e.g., where the lingual side of the interproximal region meets the gingiva). In some examples, spring bellows 108 may extend along less than the full interproximal boundary curve. By controlling the locations over which spring bellows 108 extends the interproximal region, removable dental appliance may control the locations on teeth 103 where the force is applied.

[0042] For example, in some implementations, spring bellows 108 may define at least one shear reduction region. The at least one shear reduction region may include at least one void or cutout in spring bellows 108. The at least one shear reduction region may concentrate deformation of spring bellows 108 in selected portions of spring bellows 108. For example, by including a void or cutout in spring bellows 108 in a shear reduction region, the shear force (or other forces such as compression, tension, bending, or torsion) may be effectively reduced to zero in the shear reduction region. By reducing the shear force to zero in the shear reduction regions, the force that would otherwise be present in the shear reduction region is concentrated in other portions of spring bellows 108, such as, for example, remaining portions of spring bellows 108. In this way, shear reduction regions may concentrate the force caused by deformation of spring bellows 108 when removable dental appliance 100 is worn by the patient in selected regions of the spring bellows 108.

[0043] In some examples, spring bellows 108 may overlap at least a portion of the gingiva (e.g., gingival margins) of the patient. For example, a respective spring bellows of spring bellows 108 may extend around the gingival portion of a respective shell of shells 104, where the respective tooth of teeth 103 meets the gingiva. The respective spring bellows of spring bellows 108 may be configured to anchor to at least a portion of the alveolar bone via the gingiva. For example, when worn by the patient, the respective spring bellows of spring bellows 108 may at least partially contact the gingiva overlying the alveolar process to result in at least a portion of the deformation of the respective spring bellows of spring bellows 108. In this way, removable dental appliance 100 may be configured to utilize the alveolar process as an anchor.

[0044] For example, including one or more spring bellows 108 coupled to one or more respective portions of shells 104 extending to contact the gingiva may access additional bracing provided by the extended surface indirectly engaging with the alveolar process without impeding mobility of teeth 103. Additional, or alternatively, by increasing an extent of spring bellows 108 coupled to a single shell of shells 104, greater force could be applied to a selected tooth of teeth 103 while using the more rigid alveolar process as an anchor instead of neighboring teeth. As such, another advantage could be better control of tooth movements relative to a fixed reference (the alveolar process), without causing unwanted reactionary movements of neighboring teeth.

[0045] In some examples, appliance body 102 may be formed from a unitary material, e.g., a single, uniform material. The unitary material may include a single polymer, or substantially homogeneous mixture of one or more polymers. For example, removable dental appliance

100 may consist of a single, continuous 3D printed or thermoformed component. In other examples, appliance body 102 may include a multi-layer material. The multi-layer material may include multiple layers of a single material, e.g., a single polymer, or multiple layers of a plurality of materials, e.g., two or more polymers, a polymer and another material. Multi-
5 layer materials may enable one or more portions of appliance body 102 to be formed with a plurality of layers having different elastic modulus to enable selection of force characteristics, displacement characteristics, or both of spring bellows 108. For example, removable dental appliance 100 may consist of a multilayer 3D printed or thermoformed component. Suitable polymers may include, but are not limited to, (meth)acrylate polymer; epoxy; silicones;
10 polyesters; polyurethanes; polycarbonate; thiol-ene polymers; acrylate polymers such as urethane (meth)acrylate polymers, polyalkylene oxide di(meth)acrylate, alkane diol di(meth)acrylate, aliphatic (meth)acrylates, silicone (meth)acrylate; polyethylene terephthalate based polymers such as polyethylene terephthalate glycol (PETG); polypropylene; ethylene-vinyl acetate; or the like. In the same or different examples,
15 removable dental appliance 100 may include chamfers or fillets on edges of appliance body 102 and other spaces. Such chamfers or fillets may improve patient comfort and reduce the visibility of removable dental appliance 100.

[0046] In other examples, removable dental appliance 100 may include metallic components configured to enhance forces applied by removable dental appliance 100 to one or more of
20 the surrounded teeth. For example, the metallic component may comprise a wire or ribbon extending through at least a portion of appliance body 102, such as spring bellows 108. In some examples, removable dental appliance 100 may include one or more other metal components, such as metal occlusal components, where greater durability is needed to overcome the stress of high-pressure occlusal contact, such as bruxing, or mastication. In
25 some examples, removable dental appliance 100 may include catches to connect to an anchorage device implanted within the patient, e.g., a temporary anchorage device or mini-screw. For example, catches may be positioned on anchor shells 104A–104D and 104K–104N to connect to an anchorage device on anchor teeth 103A–103D and 103K–103N. In this manner, such removable dental appliances 100 may provide a hybrid construction of
30 metal and plastic.

[0047] While plastic components may be generally clear for reduced visibility, metal components may include plating or other coloring to reduce visibility of removable dental appliance 100 when worn by the patient. For example, metal components positioned near teeth 103 of a patient when worn may include white colored coating or plating, such as, for

example, rhodium, silver, white anodized titanium, Teflon, PTFE, and the like, or be formed of a white colored metal, such as, for example, rhodium, silver, white anodized titanium, and the like. Metal components positioned elsewhere may be colored to generally match tissue color within the mouth of the patient.

5 **[0048]** FIGS. 2A to 2I illustrate different views of another example removable dental appliance 200 that includes appliance body 202. Appliance body 202 includes plurality of spring bellows 208A–208M (collectively, “spring bellows 208”) coupled to plurality of shells 204A–204N (collectively, “shells 204”) at first intersections 210A–210M (collectively, “first intersections 210”) and second intersections 212A–212M (collectively, “second intersections
10 212”).

[0049] Removable dental appliance 200 of FIGS. 2A to 2I may be the same as or substantially similar to removable dental appliance 100 of FIGS. 1A and 1B, except that FIGS. 2A to 2I do not show dental arch 101 or teeth 103 of the patient. For purposes of illustration, FIGS. 2B to 2I do not show labels for all of shells 204, spring bellows 208, first
15 intersections 210, or second intersections 212, although it is understood that appliance body 202 of FIGS. 2B to 2I defines fourteen shells (one for each tooth) and thirteen spring bellows (one spring bellows between each pair of adjacent shells). Each of shells 204, spring bellows 208, first intersections 210, and second intersections 212 may be the same as or substantially similar to shells 104, spring bellows 108, first intersections 110, and second intersections
20 112, respectively, as describe above with respect to FIGS. 1A and 1B.

[0050] FIGS. 3A and 3B illustrate an example removable dental appliance 300 that includes appliance body 302. For purposes of illustration, only plurality of spring bellows 308C–308K coupled to plurality of shells 304C–304L at first intersections 310C–310K and second intersections 312C–312K are shown in FIGS. 3A and 3B, although appliance body 302 may
25 include a plurality of spring bellows 308A–308M (collectively, “spring bellows 308”) coupled to a plurality of shells 304A–304N (collectively, “shells 304”) at first intersections 310A–310M (collectively, “first intersections 310”) and second intersections 312A–312M (collectively, “second intersections 312”). Removable dental appliance 300 of FIGS. 3A and 3B is the same as or substantially similar to removable dental appliances 100 and 200, except
30 that removable dental appliance 300 includes a plurality of shear reduction regions 314D–314I.

[0051] As shown in FIG. 3A, spring bellows 308 may include shear reductions regions 314A–314M (collectively, “shear reduction regions 314”). Generally, appliance body 302 may include shear reduction regions 314 in any location where opposite directions of motion

are desired on either side of a respective shear reduction region of shear reduction regions 314. In some examples, at least one respective spring bellows of spring bellows 308 may define at least one respective shear reduction region of shear reduction regions 314. In other examples, other portions of appliance body 302 may define shear reduction regions 314.

5 Shear reduction regions 314 may include at least one void or cutout in appliance body 302 configured to concentrate deformation of appliance body 302 in selected portions of appliance body 302, such as, e.g., selected portions of spring bellows 308. Any number of spring bellows 308 may define shear reduction regions 314 on at least one of a facial, occlusal, or lingual surface of spring bellows 308. For example, as shown in FIGS. 3A and
10 3B, shear reduction regions 314 may include voids in an occlusal surface of each of spring bellows 308D–308I. In some examples, shear reduction regions 314 may each include a single cutout in appliance body 302. In other examples, shear reduction regions 314 each may include multiple cutouts, such as, for example, a plurality of slits in spring bellows 308, a plurality of closely positioned holes in spring bellows 308, or the like. Multiple cutouts
15 may enable appliance body 302 (e.g., two adjacent shells) to maintain a desired shape or configuration compared to a single cutout. The absence of material in shear reduction regions 314 may reduce the resistance to shear deformation in shear reduction regions 314. For example, if an actual deformation of a respective spring bellows of spring bellows 308 results in a shear web that resists a desired deformation of the respective spring bellows of
20 spring bellows 308, then a respective shear reduction region 314 may remove the shear web and allow the desired deformation of the respective spring bellows of spring bellows 308. By reducing the resistance to shear deformation in shear reduction regions 314, the resistance to shear deformation that would otherwise be present in shear reduction region 314 may be reduced to enable a desired deformation of, and resulting force exerted by, spring bellows
25 308.

[0052] For example, spring bellows 308D–308I define shear reduction regions 314D–314I near an occlusal surface of spring bellows 308D–308I. Shear reduction regions 314D–314I may reduce the resistance shear deformation that would otherwise be present in the occlusal surfaces of spring bellows 308D–308I. As one example, shear reduction region 314G may
30 reduce the resistance to shear deformation that would otherwise be present in spring bellows 308G as the appliance body 302 applies a force to move shell 304G in the facial direction and shell 304H in the lingual direction. As another example, shear reduction region 314D may reduce the resistance to shear deformation that would otherwise be present in spring bellows 308D as the appliance body 302 applies a force to move shell 304D in the facial direction and

shell 304E in the lingual direction. In other examples, a respective shear reduction region near a respective occlusal surface of a respective shell may reduce the resistance to shear deformation in the respective occlusal surface of the respective shell when the respective shell is configured to cause a rotation of a respective tooth. In other examples, a respective shear reduction region near one or both of a lingual or a facial surface of a respective shell may reduce the resistance to shear deformation in the respective lingual or facial surface of the respective shell when the respective shell is configured to cause an intrusion or an extrusion. In this way, shear reduction regions 314 may reduce undesired resistance to shear deformation in selected regions of the spring bellows 108 when removable dental appliance 100 is worn by the patient.

[0053] FIG. 4 illustrates an occlusal view of an example removable dental appliance 800 that includes a plurality of spring bellows 808A–808N (collectively, “spring bellows 808”), each respective spring bellows 808 extending around a respective cervical margin or gingival margin of each respective shell of a plurality of shells 804A–804N (collectively, “shells 804”). Removable dental appliance 800 may be the same as or substantially similar to at least one of removable dental appliances 100, 200, and 300, except for the differences described herein. For example, removable dental appliance 800 may include first and second intersections coupling a respective spring bellows to respective shells, shear reduction regions, or the like. As shown in FIG. 4, removable dental appliance 800 includes spring bellows 808. Each respective spring bellows of spring bellows 808 extends around respective shell of shells 804 to overlap at least a portion of the gingiva (e.g., gingival margins) of the patient. In some examples, removable dental appliance 800 may include a combination of first spring bellows of spring bellows 808 extending around the cervical margin or gingival margin, and second spring bellows of spring bellows 808 extending only in or near the interproximal region.

[0054] In some examples, a respective spring bellows of spring bellows 808 may be relatively thicker near the cervical margin or gingival margin compared to near the occlusal surface. The relatively thicker portions of the respective spring bellows of spring bellows 808 may result in a greater force near the cervical margin or gingival margin compared to the occlusal portions to concentrate force near the cervical margin or gingival margin. By selecting a thickness of spring bellows 808 to concentrate the force in spring bellows 808 or in selected portions of spring bellows 808, removable dental appliance 800, when worn by the patient, may reduce deformation of shells 804 and increase engagement of shells 804 with the teeth.

[0055] In some examples, a respective spring bellows of spring bellows 808 is configured to anchor to at least a portion of the alveolar bone via the gingiva. For example, when worn by the patient, the respective spring bellows of spring bellows 808 at least partially contacts the gingiva overlying the alveolar process to result in at least a portion of the deformation of the
5 respective spring bellows of spring bellows 808. As discussed above, including one or more spring bellows 808 coupled to one or more respective portions of shells 804 extending to contact the gingiva may access additional bracing provided by the extended surface indirectly engaging with the alveolar process without impeding mobility of teeth 103. Additionally, or alternatively, by increasing an extent of spring bellows 808 coupled to a single shell of shells
10 804, greater force could be applied to a selected tooth while using the more rigid alveolar process as an anchor instead of neighboring teeth. As such, another advantage could be better control of tooth movements relative to a fixed reference (the alveolar process), without causing unwanted reactionary movements of neighboring teeth.

[0056] FIG. 5 is a block diagram illustrating an example computer environment 10 in which
15 clinic 14 and manufacturing facility 20 communicate information throughout a manufacturing process of a set of removable dental appliances 22 for patient 12. The set of removable dental appliances 22 may include at least one of removable dental appliances 100, 200, and 300. As discussed above, removable dental appliances 100, 200, and 300 may include at least two shells and at least one spring bellows. Initially, an orthodontic practitioner of clinic
20 14 generates one or more images of a dental anatomy of patient 12 using any suitable imaging technique and generates digital dental anatomy data 46 (e.g., a digital representation of patient's 12 tooth structure). For example, the practitioner may generate X-RAY images that can be digitally scanned. Alternatively, the practitioner may capture digital images of the patient tooth structure using, for example, conventional computed tomography (CT), laser
25 scanning, intra-oral scanning, CT scans of dental impressions, scans of dental casts poured from impressions, ultrasound instrumentation, magnetic resonance imaging (MRI), or any other suitable method of three-dimensional (3D) data acquisition. In other embodiments, the digital images may be provided using a hand-held intra-oral scanner such as the intra-oral scanner using active wavefront sampling developed by Brontes Technologies, Inc.

30 (Lexington, Massachusetts) and described in PCT Publication No. WO 2007/084727 (Boerjes, et al.), which is incorporated by reference herein. Alternatively, other intra-oral scanners or intra-oral contact probes may be used. As another option, the digital dental anatomy data 16 may be provided by scanning a negative impression of patient's 12 teeth. As still another option, the digital dental anatomy data 16 may be provided by imaging a

positive physical model of patient's 12 teeth or by using a contact probe on a model of patient's 12 teeth. The model used for scanning may be made, for example, by casting an impression of patient's 12 dentition from a suitable impression material such as alginate or polyvinylsiloxane (PVS), pouring a casting material (such as orthodontic stone or epoxy resin) into the impression, and allowing the casting material to cure. Any suitable scanning technique may be used for scanning the model, including those described above. Other possible scanning methods are described in U.S. Patent Publication No. 2007/0031791 (Cinader et al.), which is incorporated by reference herein.

[0057] In addition to providing digital images by scanning the exposed surfaces of the teeth, it is possible to image non-visible features of the dentition, such as the roots of patient's 12 teeth and patient's 12 jaw bones. In some embodiments, the digital dental anatomy data 16 is formed by providing several 3D images of these features and subsequently "stitching" them together. These different images need not be provided using the same imaging technique.

For example, a digital image of teeth roots provided with a CT scan may be integrated with a digital image of the teeth crowns provided with an intraoral visible light scanner. Scaling and registering of two-dimensional (2D) dental images with 3D dental images is described in U.S. Patent No. 6,845,175 (Kopelman, et al.), which is incorporated by reference herein, and U.S. Patent Publication No. 2004/0029068 (Badura, et al.), which is also incorporated by reference herein. Issued U.S. Patent Nos. 7,027,642 (Imgrund, et al.), which is incorporated by reference herein, and 7,234,937 (Sachdeva, et al.), which is also incorporated by reference herein, describe using techniques of integrating digital images provided from various 3D sources. Accordingly, the term "imaging" as it is used herein is not limited to normal photographic imaging of visually apparent structures, but includes imaging of dental anatomies that are hidden from view. The dental anatomy may include, but is not limited to, any portion of crowns or roots of one or more teeth of a dental arch, gingiva, periodontal ligaments, alveolar bone, cortical bone, implants, artificial crowns, bridges, veneers, dentures, orthodontic appliances, or any structure that could be considered part of the dentition before, during, or after treatment.

[0058] To generate digital dental anatomy data 16, a computer must transform raw data from the imaging systems into usable digital models. For example, for raw data representing the shapes of teeth received by a computer, the raw data is often little more than a point cloud in 3D space. Typically, this point cloud is surfaced to create 3D object models of the patient's dentition, including one or more teeth, gingival tissue, and other surrounding oral structure. For this data to be useful in orthodontic diagnosis and treatment, the computer may

“segment” dentition surfaces to produce one or more discrete, movable 3D tooth object models representing individual teeth. The computer may further separate these tooth models from the gingiva into separate objects.

5 [0059] Segmentation allows a user to characterize and manipulate the teeth arrangement as a set of individual objects. Advantageously, the computer may derive diagnostic information such as arch length, bite setting, interstitial spacing between adjacent teeth, and even American Board of Orthodontics (ABO) objective grading from these models. As a further benefit, the digital orthodontic setups may provide flexibility in the manufacturing process. By replacing physical processes with digital processes, the data acquisition step and data
10 manipulation steps can be executed at separate locations without the need to transport stone models or impressions from one location to another. Reducing or eliminating the need for shipping physical objects back and forth can result in significant cost savings to both customers and manufacturers of customized appliances.

[0060] After generating digital dental anatomy data 16, clinic 14 may store digital dental
15 anatomy data 16 within a patient record in a database. Clinic 14 may, for example, update a local database having a plurality of patient records. Alternatively, clinic 14 may remotely update a central database (optionally within manufacturing facility 20) via network 24. After digital dental anatomy data 16 is stored, clinic 14 electronically communicates digital dental anatomy data 16 to manufacturing facility 20. Alternatively, manufacturing facility 20 may
20 retrieve digital dental anatomy data 16 from the central database. Alternatively, manufacturing facility 20 may retrieve preexisting digital dental anatomy data 16 from a data source unassociated with clinic 14.

[0061] Clinic 14 may also forward prescription data 18 conveying general information regarding a practitioner’s diagnosis and treatment plan for patient 12 to manufacturing
25 facility 20. In some examples, prescription data 18 may be more specific. For example, digital dental anatomy data 16 may be a digital representation of the dental anatomy of patient 12. The practitioner of clinic 14 may review the digital representation and indicate at least one of desired movements, spacing, or final positions of individual teeth of patient 12. For example, the desired movements, spacing, and final positions of individual teeth of
30 patient 12 may affect the forces to be applied to the teeth of patient 12 at each stage of treatment by each removable dental appliance of the set of removable dental appliances 22. As discussed above, the forces applied by each removable dental appliance (e.g., removable dental appliance 100, 200, or 300) of the set of removable dental appliances 22 may be determined by selecting the dimensions, shapes, and positions of the spring bellows (e.g.,

spring bellows 108, 208, or 308) and shells (e.g., first and second shells 104, 204, or 304).

The at least one of desired movements, spacing, or final positions of individual teeth of patient 12 may enable the practitioner, a technician at manufacturing facility 20, and a computer at manufacturing facility 20 to determine at least one of selected dimensions,

5 shapes, and positions of at least one of the shells and spring bellows. In this way, digital dental anatomy data 16 may include at least one of practitioner, technician, or computer selected dimensions, shapes, and positions of at least one of the spring bellows and the shells of each of removable dental appliance of the set of removable dental appliances 22 to result in the desired movement of the teeth of patient 12. Following review of the digital
10 representation, the digital dental anatomy data 16 that includes the selected dimensions, shapes, and positions of the spring bellows and shells of each removable dental appliance of the set of removable dental appliances 22, may be forwarded to manufacturing facility 20.

Manufacturing facility 20 may be located off-site, or located with clinic 14.

[0062] For example, each clinic 14 may include its own equipment for manufacturing facility
15 20 such that a treatment plan and digital design may be performed entirely by a clinical practitioner, or an assistant, in the clinical setting, using software installed locally. The manufacturing may be performed in the clinic, as well, by using a 3D printer (or by other methods of additive manufacturing). A 3D printer allows manufacturing of intricate features of a dental appliance or a physical representation of the dental anatomy of patient 12 through
20 additive manufacturing. The 3D printer may use iterative digital designs of original dental anatomy of patient 12 as well as a desired dental anatomy of patient 12 to produce multiple digital appliances and/or digital appliance patterns customized to produce the desired dental anatomy of patient 12. Manufacturing may include post-processing to remove uncured resin and remove support structures, or to assemble various components, which may also be
25 necessary and could also be performed in a clinical setting.

[0063] Manufacturing facility 20 utilizes digital dental anatomy data 16 of patient 12 to construct the set of removable dental appliances 22 to reposition teeth of patient 12. Sometime thereafter, manufacturing facility 20 forwards the set of removable dental appliances 22 to clinic 14 or, alternatively, directly to patient 12. For example, the set of
30 removable dental appliances 22 may be an ordered set of removable dental appliances. Patient 12 then wears the removable dental appliances 22 in the set of removable dental appliances 22 sequentially over time according to a prescribed schedule to reposition the teeth of patient 12. For example, patient 12 may wear each removable dental appliance in the set of removable dental appliances 22 for a period of between about 1 week and about 6

weeks, such as between about 2 weeks and about 4 weeks, or about 3 weeks. Optionally, patient 12 may return to clinic 14 for periodic monitoring of the progress of the treatment with removable dental appliances 22.

[0064] During such periodic monitoring, a clinician may adjust the prescribed schedule of patient 12 for wearing the removable dental appliances in the set of removable dental appliances 22 sequentially over time. Monitoring generally includes visual inspection of the teeth of patient 12 and may also include imaging to generate digital dental anatomy data. In some relatively uncommon circumstances, the clinician may decide to interrupt the treatment of patient 12 with the set of removable dental appliances 22, for example, by sending the newly generated digital dental anatomy data 16 to manufacturing facility 20 in order to produce a new set of removable dental appliances 22. In the same or different examples, the clinician may send newly generated digital dental anatomy data 16 to manufacturing facility 20 following the completion of the prescribed schedule of the treatment with removable dental appliances 22. In addition, following the completion of the prescribed schedule of the treatment with removable dental appliances 22, the clinician may request a new set of removable dental appliances from manufacturing facility 20 to continue treatment of patient 12.

[0065] FIG. 6 is a flow diagram illustrating process 30 conducted at clinic 14 in accordance with one example of this disclosure. Initially, a practitioner at clinic 14 collects patient identity and other information from patient 12 and creates a patient record (32). As described, the patient record may be located within clinic 14 and optionally configured to share data with a database within manufacturing facility 20. Alternatively, the patient record may be located within a database at manufacturing facility 20 that is remotely accessible to clinic 14 via network 24 or within a database that is remotely accessible by both manufacturing facility 20 and clinic 14.

[0066] Next, digital dental anatomy data 16 of patient 12 may be generated using any suitable technique (34), to thereby create a virtual dental anatomy. Digital dental anatomy data 16 may be comprised of a two-dimensional (2D) image and/or a three-dimensional (3D) representation of the dental anatomy.

[0067] In one example, 3D representations of a dental anatomy are generated using a cone beam computerized tomography (CBCT) scanner, such as an i-CAT 3D dental imaging device (available from Imaging Sciences International, LLC; 1910 N Penn Road, Hatfield, PA). Clinic 14 stores the 3D digital dental anatomy data 16 (in the form of radiological images) generated from the CBCT scanner in the database located within clinic 14, or

alternatively, within manufacturing facility 20. The computing system processes the digital dental anatomy data 16 from the CBCT scanner, which may be in the form of a plurality of slices, to compute a digital representation of the tooth structure that may be manipulated within the 3D modeling environment.

5 **[0068]** If 2D radiological images are used (36), then the practitioner may further generate 3D digital data (38). The 3D digital dental anatomy data 16 may be produced by, for example, forming and subsequently digitally scanning a physical impression or casting of the tooth structure of patient 12. For example, a physical impression or casting of a dental arch of patient 12 may be scanned using a visible light scanner, such as an OM-3R scanner (available
10 from Laser Design, Inc. of Minneapolis, Minnesota) or an ATOS scanner (available from GOM GmbH of Braunschweig, Germany). Alternatively, the practitioner may generate the 3D digital dental anatomy data 16 of the occlusal service by use of an intra-oral scan of the dental arch of patient 12, or existing 3D tooth data. In one example, the method of forming a digital scan from a casting or an impression described in U.S. Patent No. 8,491,306, titled,
15 “REGISTERING PHYSICAL AND VIRTUAL TOOTH STRUCTURES WITH PEDESTALS,” and issued on July 23, 2013, which is incorporated herein by reference in its entirety, may be used. In the same or different examples, techniques for defining a virtual tooth surface and virtual tooth coordinate system as described in U.S. Patent Application Publication No. 2013/0325431, titled ORTHODONTIC DIGITAL SETUPS,” and published
20 on December 5, 2013 may be used, which is incorporated herein by reference in its entirety. In any case, the digital data are digitally registered within the 3D modeling environment to form a composite digital representation of a tooth structure, which may include the tooth roots as well as the occlusal surfaces.

[0069] In one example, 2D radiological images and the 3D digital data for the occlusal
25 surface of the dental arch are registered by first attaching registration markers (e.g., fiducial markers or a pedestal having known geometry) to the tooth structure of patient 12 prior to generating both the radiological images and the 3D digital scan. Thereafter, the digital representation of the registration markers within the 2D radiological image and the 3D digital data may be aligned within a 3D modeling environment using registration techniques
30 described in U.S. Patent No. 8,491,306.

[0070] In another example, 3D digital data of the tooth structure is generated by combining two 3D digital representations of the tooth structure. For example, a first 3D digital representation may be a relatively low-resolution image of the roots obtained from a CBCT scanner (e.g., an i-CAT 3D dental imaging device) and the second 3D digital representation

may be a relatively high-resolution image of the crowns of the teeth obtained from an industrial CT scan of an impression or a visible light (e.g., laser) scan of a casting of the dental arch of the patient. The 3D digital representations may be registered using a software program that enables the 3D representations to be manipulated within a computer

5 environment (e.g., Geomagic Studio software (available from 3D Systems, Inc.; 333 Three D Systems Circle, Rock Hill, South Carolina), or alternatively, registration techniques described in U.S. Patent No. 8,491,306 may be used.

[0071] Next, a computer system executing 3D modeling software renders a resultant digital representation of the tooth structure, including the occlusal surface as well as the root
10 structure of the patient's dental arch. Modeling software provides a user interface that allows the practitioner to manipulate digital representations of the teeth in 3D space relative to the digital representation of the patient's dental arch. By interacting with the computer system, the practitioner generates treatment information, such as by selecting indications of the final positions of individual teeth of patient 12, duration of a respective stage of treatment, or
15 number of treatment stages, the direction or magnitude of forces on the teeth of patient 12 during a stage of treatment, or the like (40). For example, the final positions of individual teeth of patient 12, duration of a respective stage of treatment, or number of treatment stages may affect the direction or magnitude of forces on the teeth of patient 12 at each stage of treatment by each removable dental appliance of the set of removable dental appliances 22.
20 In some examples, spring bellows may be used during at least one, but fewer than all stages of treatment. As discussed above, the forces applied by each removable dental appliance (e.g., removable dental appliances 100, 200, or 300) of the set of removable dental appliances 22 may be determined by selecting the dimensions, shapes, and positions of the spring bellows (e.g., spring bellows 108, 208, or 308) and shells (e.g., shells 104, 204, or 304). In
25 this way, updating the database with diagnostic and treatment information (40) may include determining or selecting by the practitioner, a technician, or automatically by a computer the dimensions, shapes, and positions of the spring bellows and shells of each of removable dental appliance of the set of removable dental appliances 22 to result in the desired movement of the teeth of patient 12.

30 **[0072]** Once the practitioner has finished conveying general information regarding a diagnosis and treatment plan within the 3D environment, the computer system updates the database associated with the patient record to record the prescription data 18 conveying general information regarding a diagnosis and treatment plan as specified by the practitioner (42). Thereafter, the prescription data 18 is relayed to manufacturing facility 20 for

manufacturing facility 20 to construct one or more removable dental appliances including spring bellows, such as removable dental appliances 22 (44).

[0073] Although described with respect to an orthodontic practitioner located at an orthodontic clinic, one or more of the steps discussed with respect to FIG. 6 may be performed by a remote user, such as a user located at manufacturing facility 20. For example, the orthodontic practitioner may only send radiological image data and an impression or casting of the patient to manufacturing facility 20, where a user interacts with a computer system to develop a treatment plan within a 3D modeling environment. Optionally, a digital representation of the treatment plan within the 3D modeling environment may then be transmitted to the orthodontic practitioner of clinic 14, who may review the treatment plan and either send back his or her approval, or indicate desired changes.

[0074] FIG. 7 is a block diagram illustrating an example of a client computer 50 connected to manufacturing facility 20 via network 24. In the illustrated example, client computer 50 provides an operating environment for modeling software 52. Modeling software 52 presents a modeling environment for modeling and depicting the 3D representation of the teeth of patient 12. In the illustrated example, modeling software 52 includes user interface 54, alignment module 56, and rendering engine 58.

[0075] User interface 54 provides a graphical user interface (GUI) that visually displays the 3D representation of patient's 12 teeth. In addition, user interface 54 provides an interface for receiving input from practitioner 60 of clinic 14, e.g., via a keyboard and a pointing device, a touchscreen, or the like, for manipulating patient's 12 teeth within the modeled dental arch.

[0076] Modeling software 52 may be accessible to manufacturing facility 20 via network interface 70. Modeling software 52 interacts with database 62 to access a variety of data, such as treatment data 64, 3D data 66 relating to the tooth structure of patient 12, and patient data 68. Database 62 may be represented in a variety of forms including data storage files, lookup tables, or a database management system (DBMS) executing on one or more database servers. The database management system may be a relational (RDBMS), hierarchical (HDBMS), multi-dimensional (MDBMS), object oriented (ODBMS or OODBMS) or object relational (ORDBMS) database management system. The data may, for example, be stored within a single relational database, such as SQL Server from Microsoft Corporation. Although illustrated as local to client computer 50, database 62 may be located remote from the client computer 50 and coupled to the client computer 50 via a public or private network, e.g., network 24.

[0077] Treatment data 64 describes diagnosis or repositioning information for the teeth of patient 12 selected by practitioner 60 and positioned within the 3D modeling environment. For example, treatment data 64 may include the dimensions, shapes, and positions of the spring bellows (e.g., spring bellows 108, 208, and 308) and shells (e.g., shells 104, 204, and 5 304) that may result in a selected magnitude and direction of force vectors to be applied to patient's teeth (e.g., teeth 103) throughout the treatment plans.

[0078] Patient data 68 describes a set of one or more patients, e.g., patient 12, associated with practitioner 60. For example, patient data 68 specifies general information, such as a name, birth date, and a dental history, for each patient 12.

10 [0079] Rendering engine 58 accesses and renders 3D data 66 to generate the 3D view presented to practitioner 60 by user interface 54. More specifically, 3D data 66 includes information defining the 3D objects that represent each tooth (optionally including roots), and jaw bone within the 3D environment. Rendering engine 58 processes each object to render a 3D triangular mesh based on viewing perspective of practitioner 60 within the 3D 15 environment. User interface 54 displays the rendered 3D triangular mesh to practitioner 60, and allows practitioner 60 to change viewing perspectives and manipulate objects within the 3D environment.

[0080] U.S. Patent No. 8,194,067, titled, "PLANAR GUIDES TO VISUALLY AID ORTHODONTIC APPLIANCE PLACEMENT WITHIN A THREE-DIMENSIONAL (3D) 20 ENVIRONMENT," issued on June 5, 2012, and U.S. Patent No. 7,731,495, titled, "USER INTERFACE HAVING CROSS SECTION CONTROL TOOL FOR DIGITAL ORTHODONTICS," issued on June 8, 2010, describe other examples for computer systems and 3D modeling software having user interfaces that may be used with the techniques described herein, each of which are incorporated by reference in their entireties.

25 [0081] Client computer 50 includes processor 72 and memory 74 to store and execute modeling software 52. Memory 74 may represent any volatile or non-volatile storage elements. Examples include random access memory (RAM) such as synchronous dynamic random access memory (SDRAM), read-only memory (ROM), non-volatile random access memory (NVRAM), electrically erasable programmable read-only memory (EEPROM), and 30 FLASH memory. Examples may also include non-volatile storage, such as a hard-disk, magnetic tape, a magnetic or optical data storage media, a compact disk (CD), a digital versatile disk (DVD), a Blu-ray disk, and a holographic data storage media.

[0082] Processor 72 represents one or more processors such as a general-purpose microprocessor, a specially designed processor, an application specific integrated circuit

(ASIC), a field programmable gate array (FPGA), a collection of discrete logic, or any type of processing device capable of executing the techniques described herein. In one example, memory 74 may store program instructions (e.g., software instructions) that are executed by processor 72 to carry out the techniques described herein. In other examples, the techniques
5 may be executed by specifically programmed circuitry of processor 72. In these or other ways, processor 72 may be configured to execute the techniques described herein.

[0083] Client computer 50 is configured to send a digital representation of a 3D tooth structure of a patient, and optionally, treatment data 64 and/or patient data 68 to computer 80 of manufacturing facility 20 via network 24. Computer 80 includes user interface 82. User
10 interface 82 provides a GUI that visually displays the 3D representation of the digital model of teeth. In addition, user interface 82 provides an interface for receiving input from a user, e.g., via a keyboard and a pointing device, for manipulating a patient's teeth within the digital representation of the 3D tooth structure of the patient.

[0084] Computer 80 may further be configured to automatically determine dimensions and
15 shapes of each removable dental appliance of a set of removable dental appliances 22. The dimensions and shapes of removable dental appliance 22 may include a position, dimension, and shape of shells and spring bellows such that removable dental appliance 22 is configured to reposition the one or more teeth from their initial positions to final positions when the removable dental appliance is worn by the patient. As discussed above with respect to FIGS.
20 1–3, the position, dimension, and shape of the shells, spring bellows, and shear reduction regions may affect the magnitude, direction, and length of expression of a force applied to the teeth when the removable dental appliance is worn by the patient. For example, the thickness and shape of a respective spring bellows of a plurality of spring bellows may determine, at least in part, the magnitude, direction, and length of expression of the force resulting from a
25 deformation of the respective spring bellows when the removable dental appliance is worn by the patient. The position, dimension, and shape of the shear reduction regions may concentrate deformation in selected regions of the spring bellows to control the direction of force applied to the shells. The locations where a respective spring bellows is coupled to a respective shell may also determine, at least in part, the direction of the force that may be
30 transferred from a respective spring bellows to a respective shell. Also, the location or locations of engagement of a respective shell with a respective tooth determine the direction of the force applied to the respective tooth. Computer 80 may analyze at least one of the magnitude, direction, and length of expression of the force resulting from a deformation of the respective spring bellows when the removable dental appliance is worn by the patient to

determine at least one of position, dimension, and shape of a respective shells and spring bellows that will result in a desired movement of the patient's teeth when the removable dental appliance is worn by the patient.

[0085] Computer 80 may present a representation of the removable dental appliance 22 for the user to review, including review of dimensions and shapes. Alternatively, or additionally, computer 80 may accept input from a user to determine dimensions and shapes of a set of removable dental appliances 22 for patient 12. For example, the user input may influence at least one of an automatically determined dimensions or shapes. Computer 80 may transmit, or otherwise send, a digital model of the set of removable dental appliance 22, the dimensions and shapes of the set of removable dental appliances 22, or both, to computer-aided manufacturing system 84 for production of the set of removable dental appliances 22.

[0086] Client computer 50 and computer 80 are merely conceptual representations of an example computer system. In some examples, the functionalities described with respect to client computer 50, computer 80, or both may be combined into a single computing device or distributed among multiple computing devices within a computer system. For example, cloud computing may be used for digital design of dental appliances described herein. In one example, the digital representations of tooth structures are received at one computer at the clinic, while a different computer, such as computer 80, is used to determine the shapes and dimensions of a removable dental appliance. In addition, it may not be necessary for that different computer, such as computer 80, to receive all of the same data in order for it to determine shapes and dimensions. Shapes and dimensions may be determined, at least in part, based on knowledge derived through analysis of historical cases or virtual models of exemplary cases, without receiving a complete 3D representation of the case in question. In such an example, data transmitted between client computer 50 and computer 80, or otherwise utilized to design a custom dental appliance may be significantly less than the complete data set representing a complete digital dental model of a patient.

[0087] FIG. 8 is a block diagram illustrating an example computer-aided manufacturing system 700 for construction of removable dental appliance 722. Computer-aided manufacturing system 700 may include an additive manufacturing system 702 in communication with computer 704 and coupled to build material source 710. In some examples, computer-aided manufacturing system 700 may include computer-aided manufacturing system 84 of FIG. 7. For example, computer 704 may be the same as or substantially similar to computer 80. Build material source 710 may include a source of at least one polymeric material, such as, for example, at least one of the polymeric materials of

appliance body 102 discussed above. Dental appliance 722 may be the same as or substantially similar to at least one of removable dental appliances 100, 200, and 300. In some examples, dental appliance 722 may include one dental appliance or set of dental appliances 22.

5 **[0088]** Additive manufacturing system 702 may include a moveable platform 708 and an extrusion head 706. Movable platform 708 and extrusion head 706 may be configured to manufacture dental appliance 722. For example, computer 704 may control extrusion head 706 and moveable platform 708 to manufacture removable dental appliance 722.

Controlling, by computer 704, extrusion head 706 may include at least one of controlling a material feed rate from build material source 710 to extrusion head 706, controlling a deposition rate of build material on dental appliance 722, controlling a temperature of extrusion head 706, and controlling a position of extrusion head 706. By controlling at least one of a material feed rate, a material deposition rate, a temperature of extrusion head 706, and a position of extrusion head 710, computer 704 may control manufacture of a position, dimension, and shape of at least a portion of dental appliance 722. Controlling, by computer 704, movable platform 708 may include at least one of controlling a translation of moveable platform in a plane normal to the direction of material deposition from extrusion head 706 and controlling an elevation of moveable platform along an axis substantially parallel to the direction of material deposition from extrusion head 706. By controlling at least one of a translation and elevation of moveable platform 708, computer 704 may control manufacture of a position, dimension, and shape of at least a portion of dental appliance 722.

[0100] Although FIG. 8 illustrates a computer-aided manufacturing system 700 configured for Fused Deposition Modeling (FDM), computer-aided manufacturing system 700 may also be configured for stereolithography (SLA), inverse vat polymerization additive manufacturing, inkjet/polyjet additive manufacturing, or other methods of additive manufacturing. In examples in which computer-aided manufacturing system 700 is configured for polyjet printing, computer-aided manufacturing system 700 may be configured to print multiple materials in a single print, thereby allowing a high modulus material for the rigid components of dental appliance 722 (e.g., shells) and a low modulus or elastomeric material for the less rigid components of dental appliance 722 (e.g., spring bellows). Further, with polyjet additive manufacturing, the modulus may be varied selectively across the dental appliance 722, and a different modulus may be used for the spring bellows than is used for the shells, for different parts of a spring bellows, or for different parts of a shell, for example.

Similarly, a different modulus may be used for the anchoring shells than is used for the shells used to reposition individual teeth.

[0089] FIG. 9 is a flow diagram illustrating process 500 conducted at manufacturing facility 20 for construction of set of removable dental appliances 22. In some examples, set of removable dental appliances 22 may include at least one of removable dental appliance 100, 200, and 300. Computer 80 at manufacturing facility 20 receives digital dental anatomy data 16 including initial positions of one or more teeth of the patient and prescription data 18 (502) from clinic 14. Alternatively, computer 80 may retrieve the information from a database located within or otherwise accessible by computer 80. A trained user associated with computer 80 may interact with a computerized modeling environment running on computer 80 to develop a treatment plan relative to the digital representation of the patient's tooth structure and generate prescription data 18, if clinic 14 has not already done so. In other examples, computer 80 may automatically develop a treatment plan based solely on the patient's tooth structure and predefined design constraints.

[0090] Once computer 80 receives patient's tooth structure, computer 80 determines dimensions and shapes of a removable dental appliance for the patient (504). The dimensions and shapes of the removable dental appliance are configured to reposition the one or more teeth of the patient from their initial positions to final positions when the removable dental appliance is worn by the patient. In the same or additional examples, computer 80 determines dimensions and shapes of set of removable dental appliances 22 for the patient configured to be worn in series.

[0091] In some examples, determining dimensions and shapes of the removable dental appliance includes selecting, with computer 80, the dimensions and shapes of the removable dental appliance according to a set of predefined design constraints. The set of predefined design constraints may include one or more factors, including, but not limited to, at least one of a minimum and a maximum localized force applied to one or more of the surrounded teeth, at least one of a minimum and a maximum rotational force applied to one or more of the surrounded teeth, at least one of a minimum and a maximum translational force applied to one or more of the surrounded teeth, at least one of a minimum and a maximum total force applied to one or more of the surrounded teeth, and at least one of a minimum and a maximum stress or strain applied to the removable dental appliance, when the removable dental appliance is worn by the patient and the surrounded teeth are in their initial positions. Minimum applied forces are necessary to cause pressure on the periodontal ligament sufficient to result in bone remodeling and tooth movement.

[0092] Computer 80 may use finite element analysis (FEA) techniques to analyze forces on a patient's teeth as well as the removable dental appliance during the determination of the dimensions and shapes of the removable dental appliance. For example, computer 80 may apply FEA to a solid model of the patient's teeth as the modeled teeth move from their initial positions to their final positions representing a treatment including an ordered set of removable dental appliances. Computer 80 may use FEA to select the appropriate removable dental appliance to apply the desired forces on the teeth. In addition, computer 80 may use a virtual articulator to determine contact points between the teeth throughout the movement of the modeled teeth during the treatment. Computer 80 may further include occlusal contact forces, such as cusp interdigitation forces, in the FEA forces analysis in combination with forces from the removable dental appliance during the design of removable dental appliances in an ordered set of removable dental appliances. Computer 80 may further determine an order in which teeth are to be moved to optimize the application of forces, reduce treatment time, improve patient comfort, or the like.

[0093] In some examples, determining dimensions and shapes of removable dental appliance 100, 200, or 300 includes selecting, with computer 80 thicknesses of appliance body 102, 202, or 302, such as shells 104, 204, or 304 and spring bellows 108, 208, or 308, to provide a stiffness suitable to reposition the one or more teeth of the patient from their initial positions to final positions when the removable dental appliance is worn by the patient. In some examples, a thickness of a respective shell of shells 104 may range between about 0.25 millimeters and about 2.0 millimeters thick, such as between about 0.5 and about 1.0 millimeters thick, whereas a thickness of spring bellows 108 may be between about 0.025 millimeter and about 1.0 millimeters, or between about 0.1 millimeters and about 0.75 millimeters, or between about 0.15 and about 0.6 millimeters, or about 0.3 millimeters. In some examples, computer 80 may further select a material of the removable dental appliance, for example, a material as discussed above with respect to removable dental appliance 100, according to the predefined design constraints.

[0094] The dimensions and shapes of a removable dental appliance for the patient may be presented to a user via user interface of 82 of computer 80 (506). In examples in which dimensions and shapes of the removable dental appliance are presented to a user via user interface of 82, the user may have the opportunity to adjust the design constraints or directly adjust the dimensions and shapes of the removable dental appliance before the design data is sent to computer-aided manufacturing system 84. In some examples, the dimensions and shapes of the removable dental appliance may be presented to a user by computer 80 directly

as the removable dental appliance is manufactured by computer-aided manufacturing system 84. For example, computer 80 may send a digital model of removable dental appliance 100 to computer-aided manufacturing system 84, and computer-aided manufacturing system 84 manufactures removable dental appliance according to the digital model from computer 80.

5 [0095] However, even in examples where the dimensions and shapes of a removable dental appliance for the patient may be presented to a user via user interface of 82 of computer 80, following user approval, computer 80 sends a digital model of the removable dental appliance to computer-aided manufacturing system 84 (508), and computer-aided manufacturing system 84 manufactures removable dental appliance 100 according to the digital model from
10 computer 80 (510).

[0096] In some examples, computer-aided manufacturing system 84 may include a 3D printer. Forming appliance body (e.g., appliance body 102, 202, or 302) may include printing the surfaces of shells (e.g., shells 104, 204, or 304) and spring bellows (e.g., spring bellows 108, 208, or 308) with the 3D printer. In other examples, forming the appliance body may
15 include printing representations of the patient's teeth (e.g., teeth 103) with the 3D printer, thermoforming appliance body over the representations of the patient's teeth, and trimming excess material (optionally automated by CNC or robotic machinery such as, e.g., end mill or LASER cutter) to form the shells, the spring bellows, and the shear reduction regions. The representations of the patient's teeth may include raised surfaces to facilitate forming at least
20 one of the shells, the spring bellows, and shear reduction regions in the thermoformed and trimmed appliance body.

[0097] The techniques of FIG. 9 may be applied to design and manufacture of each of an ordered set of removable dental appliances 22. For example, each removable dental appliance in the ordered set of removable dental appliances 22 may be configured to
25 incrementally reposition the teeth of the patient. In this manner, the ordered set of removable dental appliances 22 may be configured to reposition the teeth of the patient to a greater degree than any one of the removable dental appliances within the set of the removable dental appliances 22. Such an ordered set of removable dental appliances 22 may specifically be configured to incrementally reposition the one or more teeth of the patient from their initial
30 positions to final positions as the removable dental appliances of the ordered set of removable dental appliances 22 for the patient are worn sequentially by the patient.

[0098] In some examples, the techniques described with respect to FIG. 9 may be embodied within a computer-readable storage medium, such as a computer-readable storage medium of computer 50, computer 80, or both. The computer-readable storage medium may store

computer-executable instructions that, when executed, configure a processor to perform the techniques described with respect to FIG. 9.

[0099] Following the design of set of removable dental appliances 22, manufacturing facility 20 fabricates set of removable dental appliances 22 in accordance with the digital dental anatomy data 16 and prescription data 18 (510). Construction of removable dental appliances 22 may include 3D printing, thermoforming, injection molding, lost wax casting, 5-axis milling, laser cutting, hybrid plastic and metal manufacturing techniques, such as snap-fitting and overmolding, as well as other manufacturing techniques.

[0100] FIG. 10 is a flow diagram 600 illustrating successive iterations of treatment using an ordered set of removable dental appliances. The ordered set of removable dental appliances is configured to reposition one or more teeth of a patient. In some examples, the ordered set of removable dental appliances may include at least one of removable dental appliances 100, 200, and 300.

[0101] Treatment begins with the first iteration of treatment (602). At the beginning of the first iteration of treatment, the patient's teeth are at their initial positions as represented by detention state X (604). A scan of the patient's teeth, for example, as described above with respect to FIG. 5, are taken to facilitate the design of the ordered set of removable dental appliances (606). From the scan of patient's teeth, a computer, e.g., computer 50, determines two different shape and dimensions for removable dental appliances in the ordered set: first setup X_a 608A and second setup X_b 608B. Example techniques for creating a digital model of a patient's teeth are described in United States Patent No. 8,738,165 to Cinader, et al., titled, "METHODS OF PREPARING A VIRTUAL DENTITION MODEL AND FABRICATING A DENTAL RETAINER THEREFROM," and issued on May 27, 2014.

United States Patent No. 8,738,165 is herein incorporated by reference in its entirety. The computer may determine first setup X_a 608A and second setup X_b 608B by first adjusting the digital model of the patient's teeth to create a model of the desired position of the patient's teeth following the therapy. Then, the computer may create the shape and dimensions for removable dental appliances in the ordered set based on the time and forces required to move the patient's teeth from the initial positions to their desired positions. For example, the computer model may adjust the thicknesses, positions, shapes, and dimensions of shells and spring bellows of the removable dental appliances in the ordered set to produce the forces required to move the patient's teeth from the initial positions to their desired positions. The modeled forces applied by removable dental appliances in the ordered set may further be based on the incremental positional movements of the patient's teeth during the treatment. In

this manner, the computer may design each of the removable dental appliances in the ordered set according to expected forces applied on the teeth in the predicted positions of the teeth at the time during the treatment the removable dental appliances in the ordered set is to be worn by the patient.

5 **[0102]** In some examples, at least one, such as three, different removable dental appliances in the set of removable dental appliances can be manufactured using each of first setup X_a 608A and second setup X_b 608B to produce at least two, such as six, removable dental appliances in the set of removable dental appliances. For example, first setup X_a 608A may be used to manufacture first aligner $X_{a,SOFT}$ 610A, second aligner $X_{a,MEDIUM}$ 610B, and third aligner $X_{a,HARD}$ 610C; and second setup X_b 608B may be used to manufacture fourth aligner $X_{b,SOFT}$ 610D, fifth aligner $X_{b,MEDIUM}$ 610E, and sixth aligner $X_{b,HARD}$ 610F. First, second, and third aligners 610A to 610C may be substantially the same shape and dimensions, but may comprise materials with different stiffness characteristics. For example, the second and third aligners 610B and 610C may have higher stiffness characteristics than first aligner 610A, and third aligner 610C may have higher stiffness characteristics than second aligner 610B. Similarly, the fourth, fifth, and sixth aligners 610D to 610F may be substantially the same shape and dimensions, but comprise materials with different stiffness characteristics. In some examples, first aligner 610A may have the same stiffness characteristics as the fourth aligner 610D, such as a relatively soft polymeric material. Similarly, second aligner 610B may have the same stiffness characteristics as the fifth aligner 610E, such as a relatively stiffer polymeric material than first aligner 610A. Likewise, third aligner 610C may have the same stiffness characteristics as the sixth aligner 610F, such as a relatively stiffer polymeric material than second aligner 610B.

15 **[0103]** Aligners 610A to 610F in the ordered set of removable dental appliances may be worn in sequence over time by the patient. For example, each of aligners 610A to 610F in the ordered set of removable dental appliances may be worn between about 1 weeks and about 6 weeks, such as between about 2 weeks and about 4 weeks, or about 3. Following the treatment plan using aligners 610A to 610F, the patient's teeth may be at their final positions for the first iteration of treatment as represented by detention state $X+1$ (612).

20 **[0104]** Once patient's teeth are at or near dentition state $X+1$, the patient may return to the clinician who may evaluate the result of the first iteration of treatment (614). If the first iteration of treatment has resulted in acceptable final positions of the patient's teeth, then the treatment may be ended (616). However, if the first iteration of treatment did not result in acceptable final positions of the patient's teeth, one or more additional iterations of treatment

may be performed. To begin the next iteration of treatment, the clinician may take another scan of the patient's teeth to facilitate the design of a subsequent ordered set of removable dental appliances (606). In some examples, evaluation of the result of the first iteration of treatment may include taking another scan of the patient's teeth, in which case beginning the next iteration of treatment may simply involve forwarding the digital model of the patient's teeth to a manufacturing facility so that another ordered set of removable dental appliances may be manufactured for the patient based on the new positions of the patient's teeth. In yet other examples, the newly acquired scan may be used to create one or more iterations of removable dental appliances in the clinician's facility.

5 [0105] The techniques of FIG. 10 represent one specific example, and a variety of modifications may be made to the techniques of FIG. 10 within the spirit of this disclosure. For example, an ordered set of removable dental appliances may include more or less than six removable dental appliances. As another example, each removable dental appliance in the ordered set of removable dental appliances may have unique shapes and dimensions, and each removable dental appliance in the ordered set of removable dental appliances may be made of material having substantially the same or similar stiffness characteristics. As another example, each removable dental appliance in the ordered set of removable dental appliances may include a selected thickness of the spring bellows. For example, first aligner $X_{a, \text{SOFT}}$ 610A, second aligner $X_{a, \text{MEDIUM}}$ 610B, and third aligner $X_{a, \text{HARD}}$ 610C may be a first thickness of the spring bellows; whereas fourth aligner $X_{b, \text{SOFT}}$ 610D, fifth aligner $X_{b, \text{MEDIUM}}$ 610E, and sixth aligner $X_{b, \text{HARD}}$ 610F may be a second, different thickness of the spring bellows. The first thickness may be less than the second thickness. As another example, each removable dental appliance in the ordered set of removable dental appliances may include selected dimensions of one or more spring bellows, selected shapes of one or more spring bellows, or both.

EXAMPLES

10 [0106] FIGS. 11A and 11B illustrate a directional deformation diagram 410 and an equivalent stress diagram 420 for a modeled shell 411 of a removable dental appliance that does not include spring bellows. FIGS. 11A and 11B show the lingual surface 412 and facial surface 414 of shell 411 of a removable dental appliance without spring bellows. For purposes of modeling, edge 416 of facial surface 414 was fixed along the x-axis, y-axis, and z-axis, and the other three vertical edges of the shell were fixed along the z-axis. Deformation of shell 411 was modeled with a 2 Newton (204 gram) force applied to the center of the inside facial surface 414 in the facial direction. Shell 411 material was modeled

as DURAN, available from Scheu Dental, Iserlohn, Germany, with an elastic modulus of approximately 2200 MPa. The modeled removable dental appliance included a nominal shell 411 thickness of 0.50 millimeters. The maximum strain was 0.53%. As shown in FIG. 11A, deformation in the z-axis was distributed across face 418 of facial surface 414. As shown in FIG. 11B, stress was distributed across face 418 of facial surface 414. The examples of FIGS. 11A and 11B show that without spring bellows stress and deformation of a removable dental appliance when worn by a patient is distributed across the shells of the removable dental appliance. As discussed above, distribution of deformation and stress in the shells may not be desirable because it may reduce engagement of the shells with the respective teeth, reducing control of the movement of the teeth.

[0107] FIGS. 12A and 12B illustrate a directional deformation diagram and an equivalent stress diagram for a modeled shell 431 of a removable dental appliance that includes spring bellows 438A and 438B. FIGS. 12A and 12B show the lingual surface 432 and facial surface 434 of an example shell 431 of a removable dental appliance with spring bellows 438A and 438B (e.g., removable dental appliance 100 or 200). For purposes of modeling, vertical edge 436 of spring bellows 438A was fixed along the x-axis, y-axis, and z-axis, and the other three vertical edges of the shell were fixed along the z-axis. Deformation of shell 431 was modeled with a 2 Newton (204 gram) force applied to the center of the inside facial surface 434 in the facial direction. Shell 431 material was modeled as DURAN, available from Scheu Dental, Iserlohn, Germany, with an elastic modulus of approximately 2200 MPa. The modeled removable dental appliance included a nominal shell 431 thickness of 0.50 millimeters, and a nominal spring bellows 438A and 438B thickness of 0.30 millimeters. The maximum strain was 0.54%. As shown in FIG. 12A, deformation in the z-axis is concentrated in spring bellows 438A and 438B and reduced across the face of facial surface 434 compared to FIG. 11A. Also, the maximum magnitude of the directional deformation of facial surface 434 along the z-axis increased, indicating the removable dental appliance could move a tooth farther compared to the appliance shown in FIG. 11. As shown in FIG. 12B, stress is concentrated in spring bellows 438A and 438B and is reduced across the face of facial surface 434 compared to FIG. 11B. The example of FIGS. 5A and 5B show that spring bellows may reduce stress and deformation of the shells compared to a removable dental appliance without spring bellows. The reduction in stress and deformation of the shells compared to a removable dental appliance without spring bellows may be more pronounced if the shells were made thicker and the spring bellows made thinner. As discussed above,

reducing of the deformation in the shells is desirable, because it may increase engagement of the shells with the respective teeth to improve control of the movement of the teeth.

[0108] FIGS. 13A and 13B illustrate a directional deformation diagram 450 and an equivalent stress diagram 460 for a modeled shell 451 of a removable dental appliance that includes spring bellows 458A–458D defining shear reduction regions (e.g., removable dental appliance 300). FIGS. 13A and 13B show the lingual surface 452 and facial surface 454 of shell 451 of a removable dental appliance with spring bellows 458A–458D defining shear reduction regions. The shear reduction regions may include a void in the appliance body extending along shell 451 between each of spring bellows 458A and 458B, and spring bellows 458C and 458D. For purposes of modeling, vertical edge 456 of spring bellows 458C was fixed along the x-axis, y-axis, and z-axis, and the other three vertical edges of the shell were fixed along the z-axis. Deformation of shell 451 was modeled with a 2 newton (204 gram) force applied to the center of the inside facial surface 454 in the facial direction. Shell 451 material was modeled as DURAN, available from Scheu Dental, Iserlohn, Germany, with an elastic modulus of approximately 2200 MPa. The modeled removable dental appliance included a nominal shell 451 thickness of 0.50 millimeters, and a nominal spring bellows 458A–458D thickness of 0.30 millimeters. The maximum strain was 1.23%. As shown in FIG. 13A, deformation in the z-axis is concentrated in spring bellows 458A–458D and reduced across the face of facial surface 454 compared to FIGS. 11A and 12A. As shown in FIG. 13B, stress is concentrated in spring bellows 458A–458D and is reduced across the face of facial surface 454 compared to FIGS. 11B and 12B. The example of FIGS. 13A and 13B show that spring bellows with shear reduction regions may reduce stress and deformation of the shell compared to a removable dental appliance without spring bellows, or a removable dental appliance with spring bellows but without shear reduction regions. As discussed above, reducing of the deformation in the shells is desirable, because it may increase engagement of the shells with the respective teeth to improve control of the movement of the teeth.

[0109] Various examples have been described. These and other examples are within the scope of the following claims.

30

WHAT IS CLAIMED IS:

1. A removable dental appliance comprising:
an appliance body configured to at least partially surround two or more teeth of a
5 patient, wherein the appliance body comprises:
 - a first shell shaped to receive a first tooth of the patient;
 - a second shell shaped to receive a second tooth of the patient; and
 - at least one spring bellows comprising an arcuate displacement of the
appliance body extending over and away from at least a portion of an interproximal
10 region between the first tooth and the second tooth to join the first shell and the
second shell, wherein the at least one spring bellows is configured to apply a force
between the first shell and the second shell to cause movement of at least one of the
first tooth and the second tooth toward a desired position when the removable dental
appliance is worn by the patient.
- 15 2. The removable dental appliance of claim 1, wherein the removable dental appliance
comprises an aligning tray.
3. The removable dental appliance of claim 1 or 2, wherein the at least one spring
20 bellows overlaps at least a portion of the gingival margin.
4. The removable dental appliance of any one of claims 1 to 3, wherein a thickness of
the at least one spring bellows is less than a thickness of the first and second shells to at least
one of concentrate strain in the at least one spring bellows or reduce deformation of the first
25 shell and the second shell when the removable dental appliance is worn by the patient.
5. The removable dental appliance of any one of claims 1 to 4, wherein a thickness of
the at least one spring bellows is between about 0.025 millimeters and about 1.0 millimeter,
and the thickness of the first and second shells is between about 0.25 millimeters and about
30 2.0 millimeters.
6. The removable dental appliance of any one of claims 1 to 5, wherein the thickness of
the at least one spring bellows is constant along an interproximal boundary curve extending
from the lingual gingiva along the interproximal region to the facial gingiva.

7. The removable dental appliance of any one of claims 1 to 5, wherein the thickness of the at least one spring bellows varies along an interproximal boundary curve extending from the lingual gingiva along the interproximal region to the facial gingiva.
- 5
8. The removable dental appliance of any one of claims 1 to 7, wherein the arcuate displacement comprises an outer radius of curvature between about 0.5 millimeters and about 2 millimeters.
- 10
9. The removable dental appliance of claim 8, wherein the outer radius of curvature is substantially constant along an interproximal boundary curve extending from the lingual gingiva along the interproximal region to the facial gingiva.
10. The removable dental appliance of claim 8, wherein the outer radius of curvature varies along an interproximal boundary curve extending from the lingual gingiva along the interproximal region to the facial gingiva.
- 15
11. The removable dental appliance of any one of claims 1 to 10, wherein at least a portion of an edge of the at least one spring bellows joins at least a portion of an edge of the first shell at a first intersection.
- 20
12. The removable dental appliance of any one of claims 1 to 11, wherein at least a portion of an edge of the at least one spring bellows joins at least a portion of the second shell at a second intersection displaced by a distance from an edge of the second shell.
- 25
13. The removable dental appliance of any one of claims 1 to 12, wherein at least one spring bellows defines a shear reduction region.
14. The removable dental appliance of claim 13, wherein the shear reduction region comprises a single cutout in the at least one spring bellows.
- 30
15. The removable dental appliance of claim 13, wherein the shear reduction region comprises a plurality of cutouts in the at least one spring bellows.

16. The removable dental appliance of any one of claims 1 to 15, wherein the at least one spring bellows extends around at least a portion of at least one of a cervical margin or a gingival margin of at least one of the first tooth or the second tooth.
- 5 17. The removable dental appliance of any one of claims 1 to 16, wherein the appliance body comprises a unitary three-dimensionally printed polymeric material.
18. A system comprising:
an ordered set of removable dental appliances configured to reposition one or more
10 teeth of a patient, each removable dental appliance in the set of removable dental appliances comprising a respective appliance body configured to at least partially surround two or more teeth of the patient, wherein each respective appliance body comprises:
a first shell shaped to receive a first tooth of the patient;
a second shell shaped to receive a second tooth of the patient; and
15 at least one spring bellows comprising an arcuate displacement of the appliance body extending over and away from at least a portion of an interproximal region between the first tooth and the second tooth to join the first shell and the second shell, wherein the at least one spring bellows is configured to apply a force between the first shell and the second shell to cause movement of at least one of the
20 first tooth and the second tooth toward a desired position when the removable dental appliance is worn by the patient.
19. The system of claim 18, wherein each removable dental appliance in the set of removable dental appliances comprises an aligning tray.
25
20. The system of claim 18 or 19, wherein the at least one spring bellows overlaps at least a portion of the gingival margin.
21. The system of any one of claims 18 to 20, wherein a thickness of the at least one
30 spring bellows is less than a thickness of the first and second shells to at least one of concentrate strain in the at least one spring bellows or reduce deformation of the first shell and the second shell when the removable dental appliance is worn by the patient.

22. The system of any one of claims 18 to 21, wherein a thickness of the at least one spring bellows is between about 0.025 millimeters and about 1.0 millimeter, and the thickness of the first and second shells is between about 0.25 millimeters and about 2.0 millimeters.
- 5 23. The system of any one of claims 18 to 22, wherein the thickness of the at least one spring bellows is constant along an interproximal boundary curve extending from the lingual gingiva along the interproximal region to the facial gingiva.
24. The system of any one of claims 18 to 22, wherein the thickness of the at least one
10 spring bellows varies along an interproximal boundary curve extending from the lingual gingiva along the interproximal region to the facial gingiva.
25. The system of any one of claims 18 to 24, wherein the arcuate displacement
15 comprises an outer radius of curvature between about 0.5 millimeters and about 2 millimeters.
26. The system of claim 25, wherein the outer radius of curvature is substantially constant
20 along an interproximal boundary curve extending from the lingual gingiva along the interproximal region to the facial gingiva.
27. The system of claim 25, wherein the outer radius of curvature varies along an interproximal boundary curve extending from the lingual gingiva along the interproximal region to the facial gingiva.
- 25 28. The system of any one of claims 18 to 27, wherein at least a portion of an edge of the at least one spring bellows joins at least a portion of an edge of the first shell at a first intersection.
29. The system of any one of claims 18 to 28, wherein at least a portion of an edge of the
30 at least one spring bellows joins at least a portion of the second shell at a second intersection displaced by a distance from an edge of the second shell.
30. The system of any one of claims 18 to 29, wherein at least one spring bellows defines a shear reduction region.

31. The system of claim 30, wherein the shear reduction region comprises a single cutout in the at least one spring bellows.
- 5 32. The system of claim 30, wherein the shear reduction region comprises a plurality of cutouts in the at least one spring bellows.
33. The system of any one of claims 18 to 32, wherein the at least one spring bellows extends around at least one of a cervical margin or a gingival margin of at least one of the
10 first tooth or the second tooth.
34. The system of any one of claims 18 to 33, wherein the appliance body comprises a unitary three-dimensionally printed polymeric material.
- 15 35. A method comprising:
forming a model of dental anatomy of a patient; and
forming, based on the model, a removable dental appliance comprising an appliance body configured to at least partially surround two or more teeth of the patient, wherein the appliance body comprises:
20 a first shell shaped to receive a first tooth of the patient;
a second shell shaped to receive a second tooth of the patient; and
at least one spring bellows comprising an arcuate displacement of the appliance body extending over and away from at least a portion of an interproximal region between the first tooth and the second tooth to join the first shell and the
25 second shell, wherein the at least one spring bellows is configured to apply a force between the first shell and the second shell to cause movement of at least one of the first tooth and the second tooth toward a desired position when the removable dental appliance is worn by the patient.
- 30 36. The method of claim 35, wherein the removable dental appliance comprises an aligning tray.
37. The method of claim 35 or 36, wherein the at least one spring bellows overlaps at least a portion of the gingival margin.

38. The method of any one of claims 35 to 37, wherein a thickness of the at least one spring bellows is less than a thickness of the first and second shells to at least one of concentrate strain in the at least one spring bellows or reduce deformation of the first shell and the second shell when the removable dental appliance is worn by the patient.
39. The method of any one of claims 35 to 38, wherein a thickness of the at least one spring bellows is between about 0.025 millimeters and about 1.0 millimeter, and the thickness of the first and second shells is between about 0.25 millimeters and about 2.0 millimeters.
40. The method of any one of claims 35 to 39, wherein the thickness of the at least one spring bellows is constant along an interproximal boundary curve extending from the lingual gingiva along the interproximal region to the facial gingiva.
41. The method of any one of claims 35 to 40, wherein the thickness of the at least one spring bellows varies along an interproximal boundary curve extending from the lingual gingiva along the interproximal region to the facial gingiva.
42. The method of any one of claims 35 to 41, wherein the arcuate displacement comprises an outer radius of curvature between about 0.5 millimeters and about 2 millimeters.
43. The method of claim 42, wherein the outer radius of curvature is substantially constant along an interproximal boundary curve extending from the lingual gingiva along the interproximal region to the facial gingiva.
44. The method of claim 42, wherein the outer radius of curvature varies along an interproximal boundary curve extending from the lingual gingiva along the interproximal region to the facial gingiva.
45. The method of any one of claims 35 to 44, at least a portion of an edge of the at least one spring bellows joins at least a portion of an edge the first shell at a first intersection.

46. The method of any one of claims 35 to 45, wherein at least a portion of an edge of the at least one spring bellows joins at least a portion of the second shell at a second intersection displaced by a distance from an edge of the second shell.

5 47. The method of any one of claims 35 to 46, wherein at least one spring bellows defines a shear reduction region.

48. The method of claim 47, wherein the shear reduction region comprises a single cutout in the at least one spring bellows.

10

49. The method of claim 47, wherein the shear reduction region comprises a plurality of cutouts in the at least one spring bellows.

50. The method of any one of claims 35 to 49, wherein the at least one spring bellows
15 extends around at least one of a cervical margin or a gingival margin of at least one of the first tooth or the second tooth.

51. The method of any one of claims 35 to 50, wherein the appliance body comprises a
unitary three-dimensionally printed polymeric material.

20

52. A method comprising:

receiving, by a computing device, a digital representation of a three-dimensional (3D) dental anatomy of a patient, the dental anatomy providing initial positions of one or more teeth of the patient;

5 determining, by the computing device, dimensions and shapes of a removable dental appliance for the patient, wherein:

the removable dental appliance comprises an appliance body configured to at least partially surround two or more teeth of the patient,

10 the dimensions and shapes of the removable dental appliance are configured to reposition the one or more teeth of the patient from initial positions to desired positions when the removable dental appliance is worn by the patient, and

the dimensions and shapes of the removable dental appliance comprise:

a position, dimension and shape of a first shell shaped to receive a first tooth of the patient;

15 a position, dimension and shape of a second shell shaped to receive a second tooth of the patient;

a position, dimension, and shape of at least one spring bellows comprising an arcuate displacement of the appliance body extending over and away from at least a portion of an interproximal region between the first tooth and the second tooth to join the first shell and the second shell, wherein the at least one spring bellows is configured to apply a force between the first shell and the second shell to cause movement of at least one of the first tooth and the second tooth toward a desired position when the removable dental appliance is worn by the patient; and

25 transmitting, by the computing device, a representation of the removable dental appliance to a computer-aided manufacturing system.

53. The method of any one of claims 52, wherein the removable dental appliance comprises an aligning tray.

30

54. The method of claim 52 or 53, wherein the three-dimensional (3D) dental anatomy of the patient further includes at least some portion of tooth roots, gingiva, periodontal ligaments (PDL), alveolar bone, or cortical bone.

55. The method of any one of claims 52 to 54, wherein determining, by the computing device, dimensions and shapes of the removable dental appliance includes accepting input from a user, wherein the input influences at least one of the dimensions and shapes.

5 56. The method of any one of claims 52 to 55, wherein determining, by the computing device, dimensions and shapes of the removable dental appliance includes automatically determining at least one of the dimensions and shapes.

10 57. The method of any one of claims 52 to 56, wherein determining, by the computing device, dimensions and shapes of the removable dental appliance includes presenting a representation of the removable dental appliance to a user for review.

15 58. The method of any one of claims 52 to 57, wherein transmitting the representation of the removable dental appliance includes sending a digital model of the removable dental appliance from the computing device to the computer-aided manufacturing system, and manufacturing at least a portion of the removable dental appliance with the computer-aided manufacturing system according to the digital model from the computing device.

20 59. The method of claim 58, wherein the computer-aided manufacturing system comprises a 3D printer, and at least some portion of the removable dental appliance is formed using the 3D printer.

25

60. The method of any one of claims 52 to 59, further comprising:
determining, by the computing device, dimensions and shapes of each of an ordered
30 set of a removable dental appliances for the patient, the removable dental appliance being one of the ordered set of removable dental appliances for the patient,

wherein each removable dental appliance in the ordered set of removable dental appliances is configured to incrementally reposition the teeth of the patient to a more advanced position than any one of the earlier removable dental appliances within the set of the removable dental appliances.

5

61. The method of any one of claims 52 to 60, wherein determining, by the computing device, dimensions and shapes of the removable dental appliance includes selecting, by the computing device, the dimensions and shapes of the removable dental appliance according to a set of predefined design constraints, the set of predefined design constraints including one or more of a group consisting of:

10

a minimum and a maximum localized force applied to one or more of the surrounded teeth, the first shell, or the second shell;

a minimum and a maximum rotational force applied to one or more of the surrounded teeth, the first shell, or the second shell;

15

a minimum and a maximum translational force applied to one or more of the surrounded teeth, the first shell, or the second shell;

a minimum and a maximum total force applied to one or more of the surrounded teeth, the first shell, or the second shell; and

20

a minimum and a maximum strain applied to the removable dental appliance when worn by the patient.

62. The method of any one of claims 52 to 61, wherein determining, by the computing device, dimensions and shapes of the removable dental appliance includes modifying the initial positions of one or more teeth of the patient to produce a modified dental anatomy,

25

wherein

the modified dental anatomy represents an incremental repositioning of the one or more teeth of the patient as compared to the initial positions of the one or more teeth of the patient, and

30

the dimensions and shapes of the removable dental appliance conform to the modified dental anatomy.

63. The method of any one of claims 52 to 62, wherein determining, by the computing device, dimensions and shapes of the removable dental appliance further comprise a position, dimension, and shape of a shear reduction region.
- 5 64. The method of claim 63, wherein the shear reduction region comprises at least one cutout in the at least one spring bellows.
65. The method of any one of claims 52 to 64, wherein determining, by the computing device, dimensions and shapes of the removable dental appliance includes selecting a
10 thickness of the at least one spring bellows to provide a stiffness suitable to reposition the one or more teeth of the patient from their initial positions to adjusted positions when the removable dental appliance is worn by the patient.
66. The method of any one of claims 52 to 65, wherein the at least one spring bellows
15 overlaps at least a portion of the gingival margin.
67. The method of any one of claims 52 to 66, wherein:
a thickness of the at least one spring bellows is less than a thickness of the first and second shells to at least one of concentrate strain in the at least one spring bellows or reduce
20 deformation of the first shell and the second shell when the removable dental appliance is worn by the patient.
68. The removable dental appliance of any one of claims 52 to 67, wherein the at least one spring bellows extends around at least one of a cervical margin or a gingival margin of at
25 least one of the first tooth or the second tooth.
69. The method of any one of claims 52 to 68, wherein the appliance body comprises a unitary three-dimensionally printed polymeric material.
- 30 70. The method of any one of claims 52 to 69, wherein the computing device includes a plurality of computing devices operably connected via one or more computer networks.

71. A non-transitory computer-readable storage medium that stores computer system-executable instructions that, when executed, configure a processor to perform the method of any of claims 52 to 70.

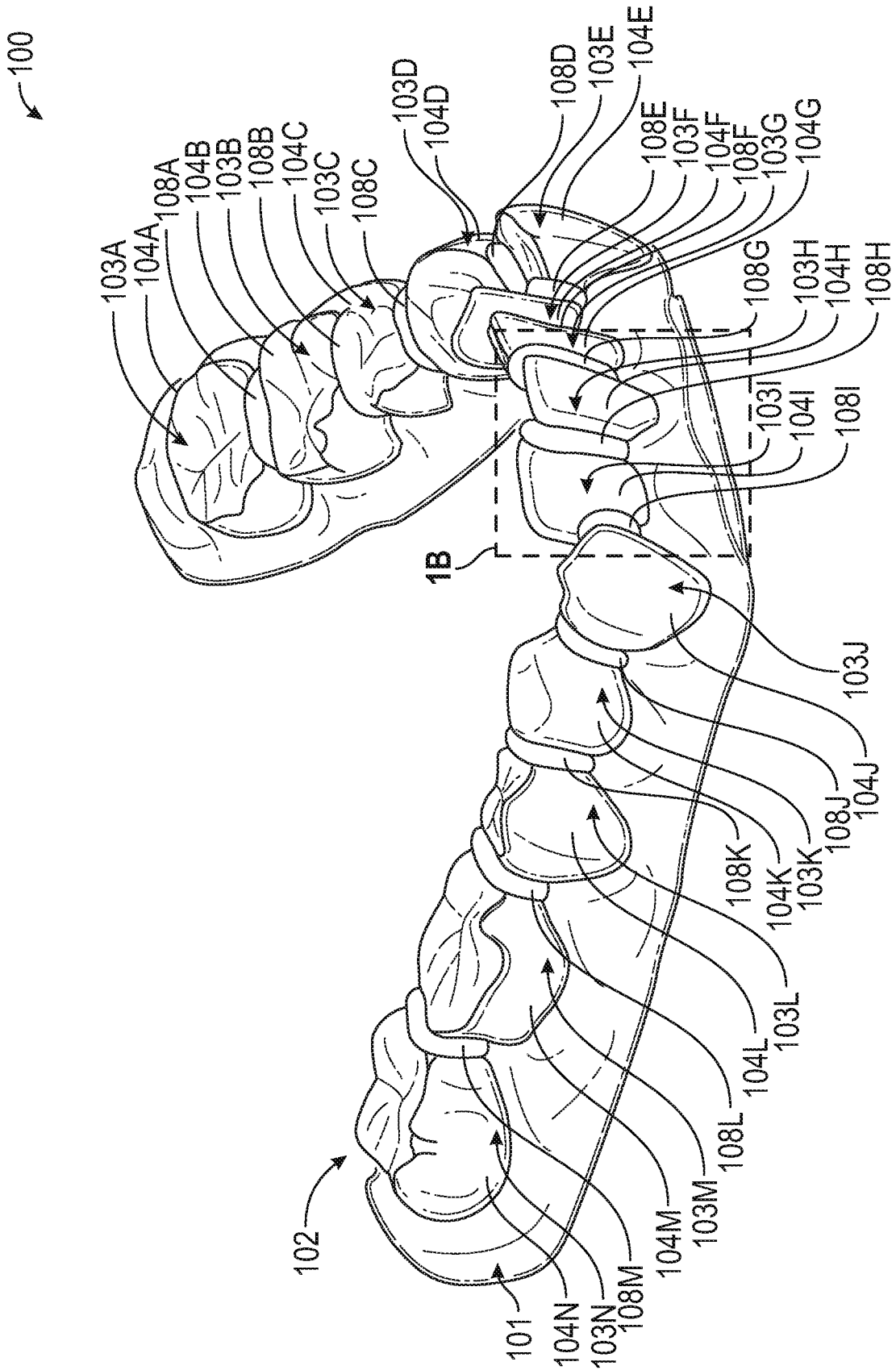

FIG. 1A

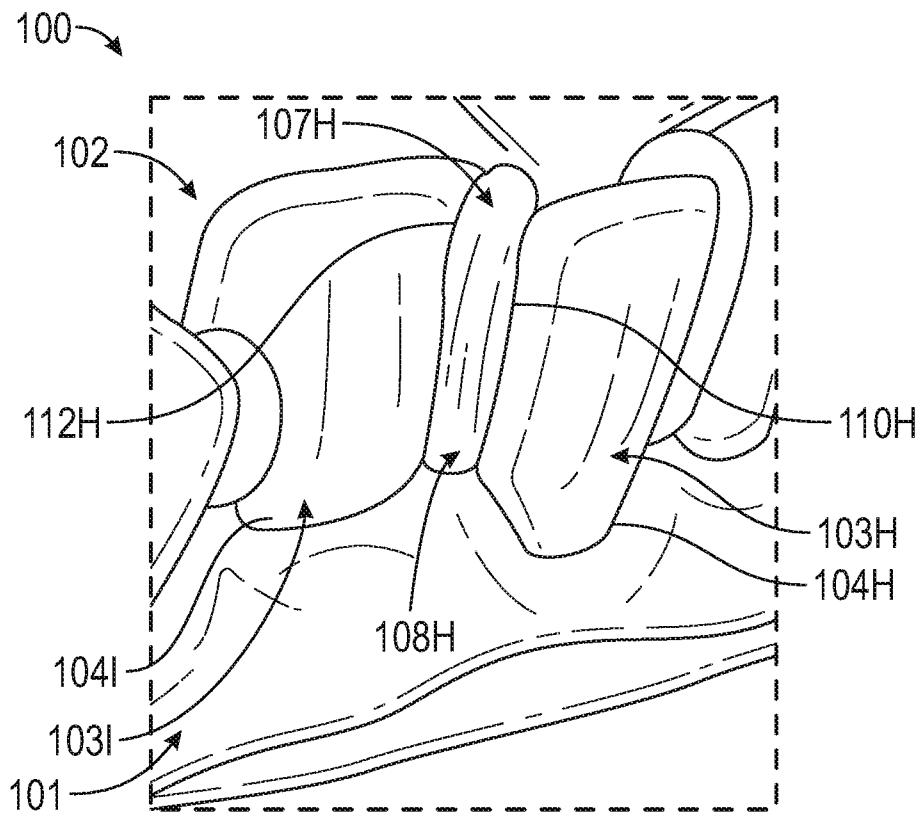

FIG. 1B

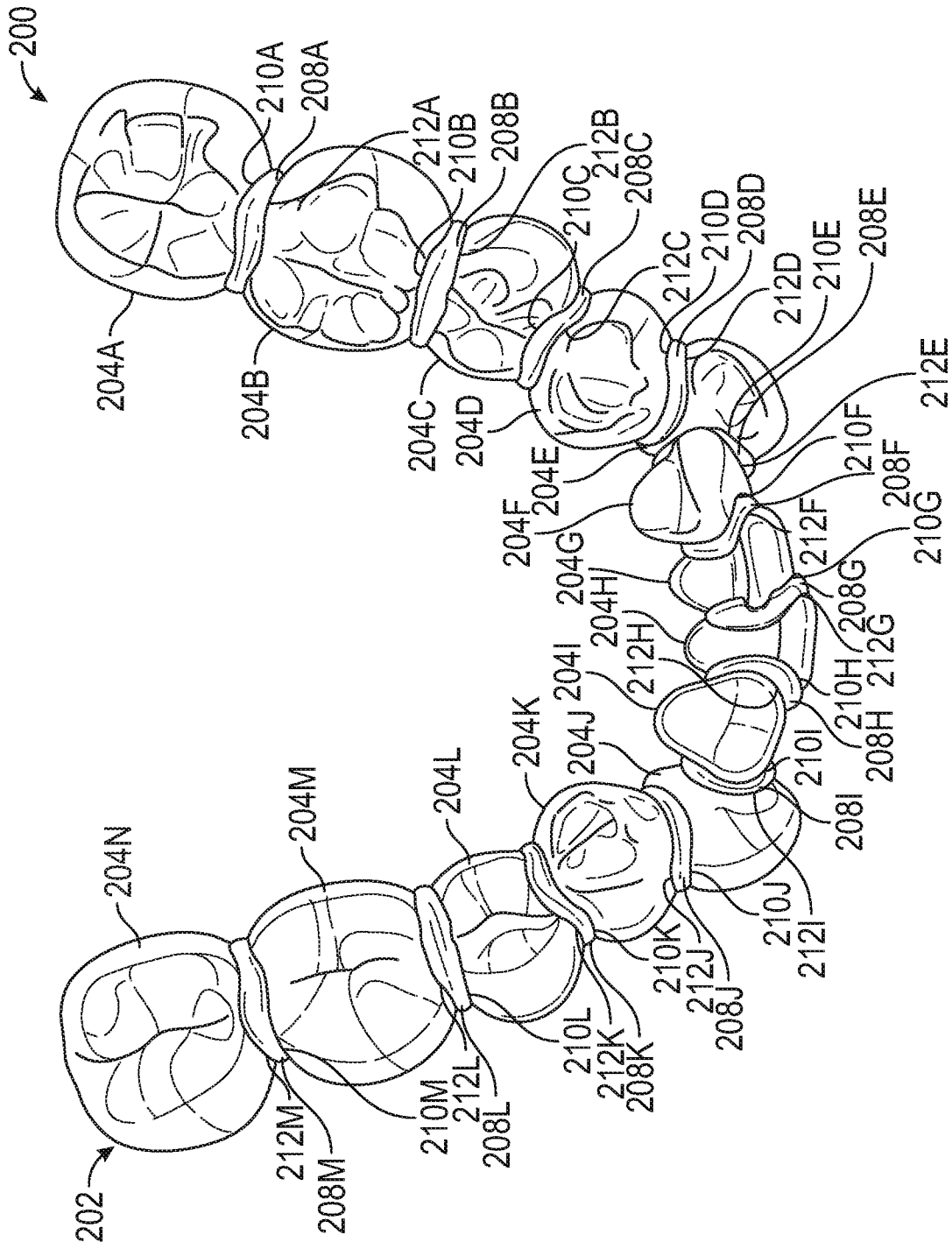

FIG. 2A

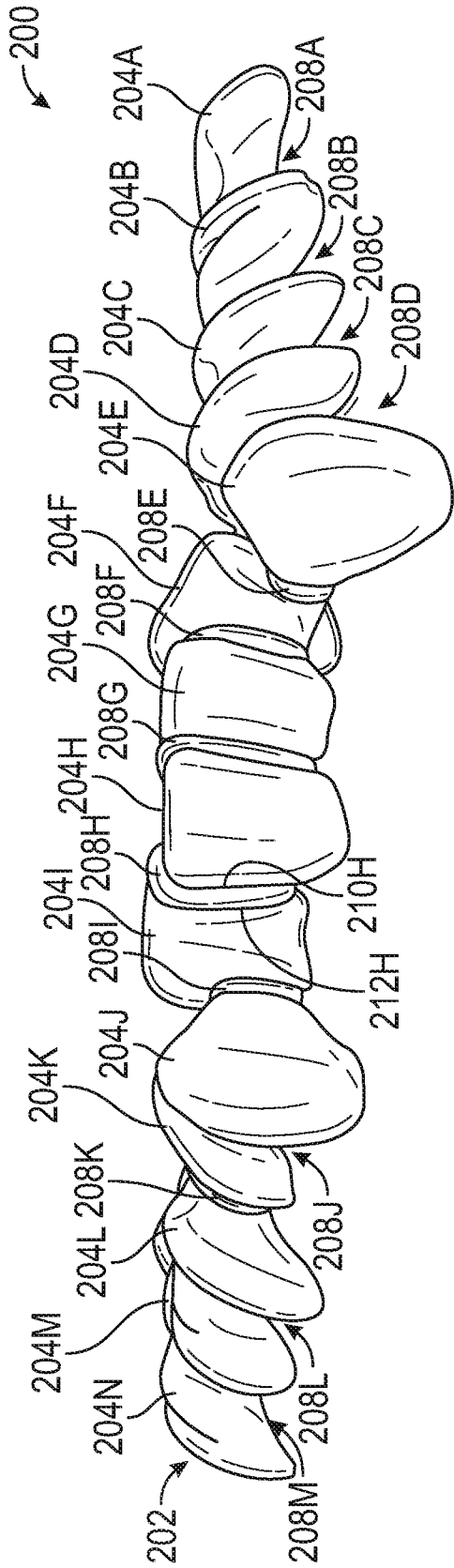

FIG. 2B

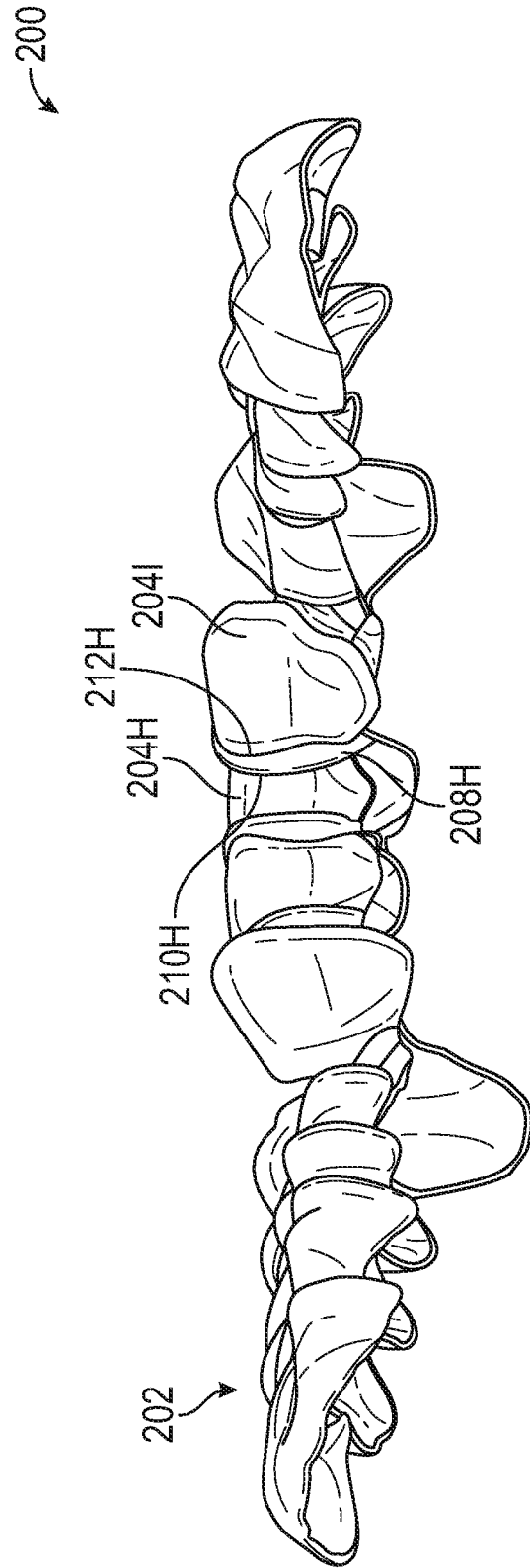

FIG. 2C

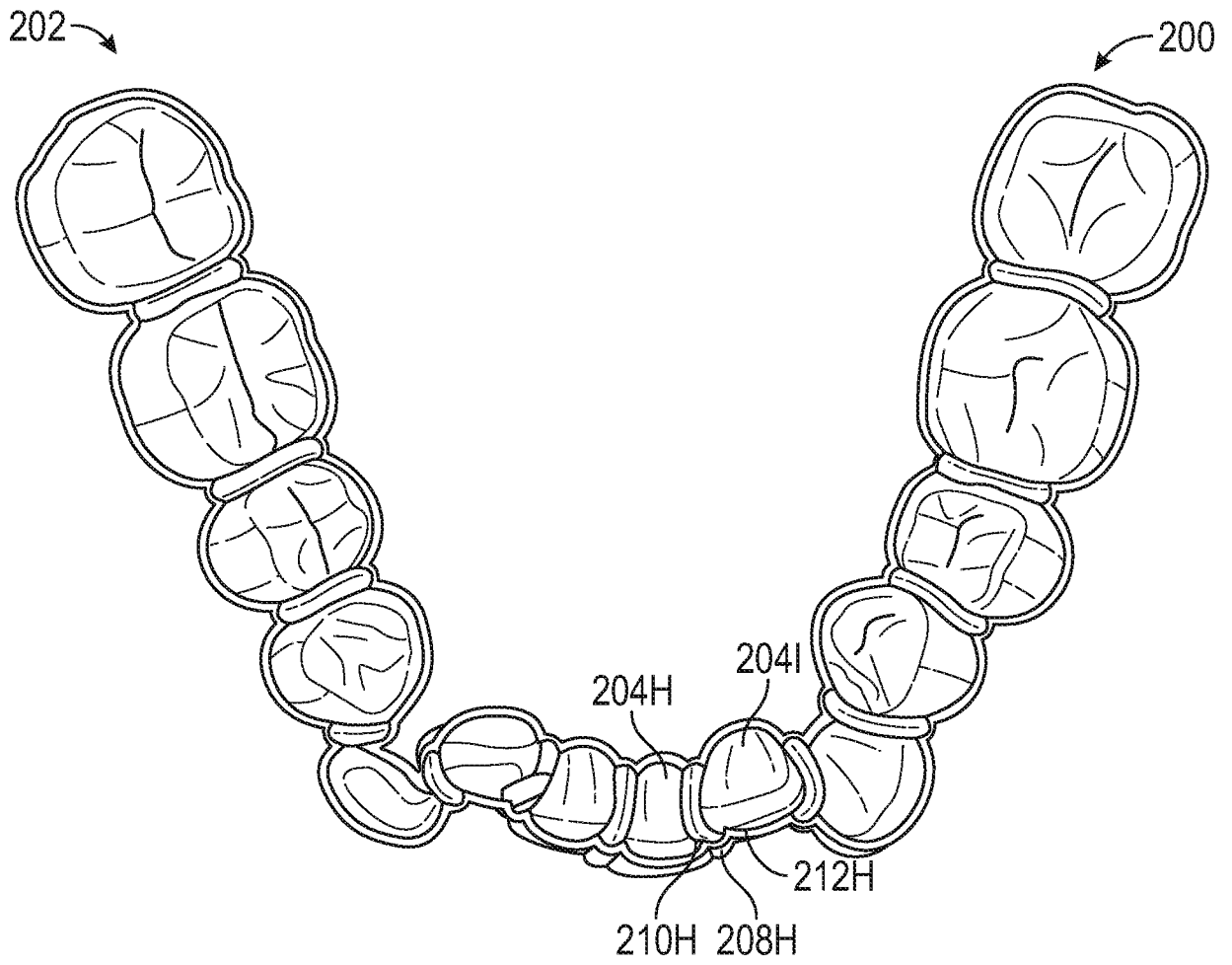

FIG. 2D

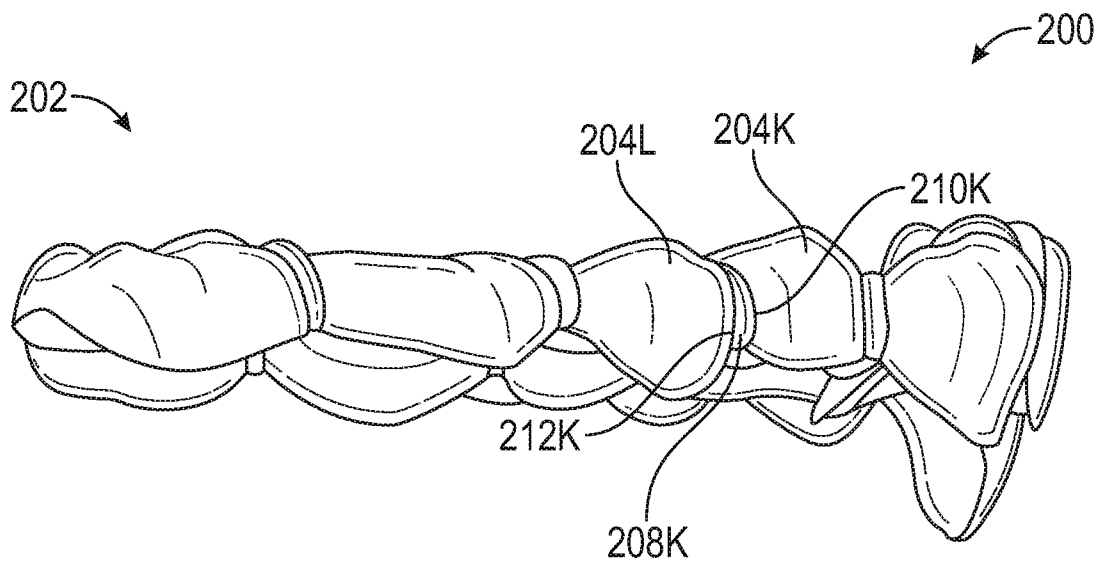

FIG. 2E

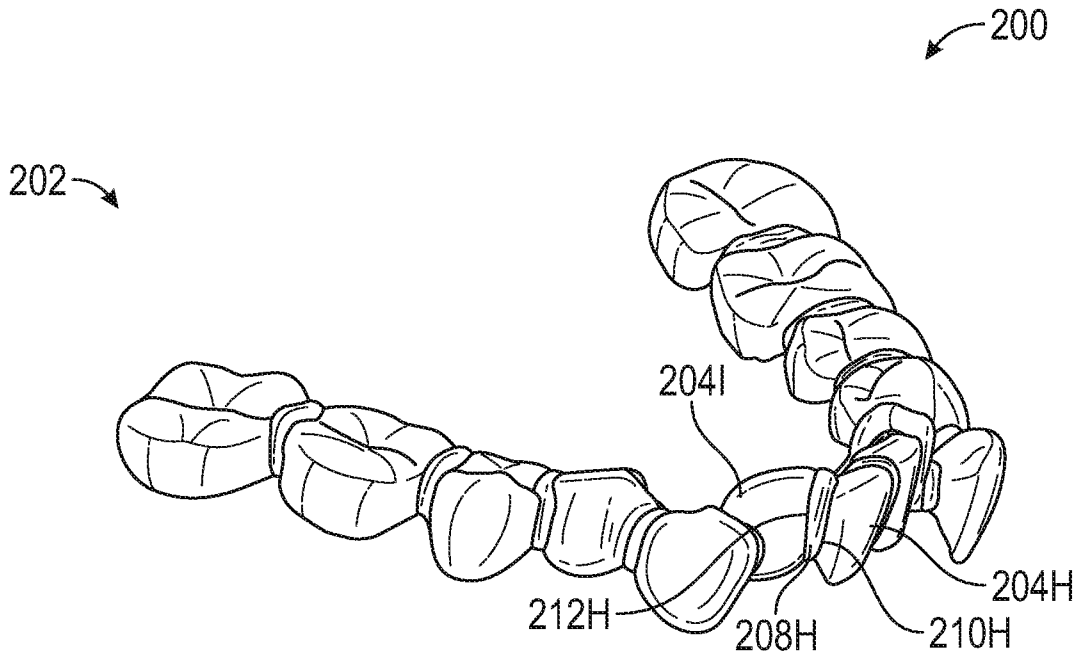

FIG. 2F

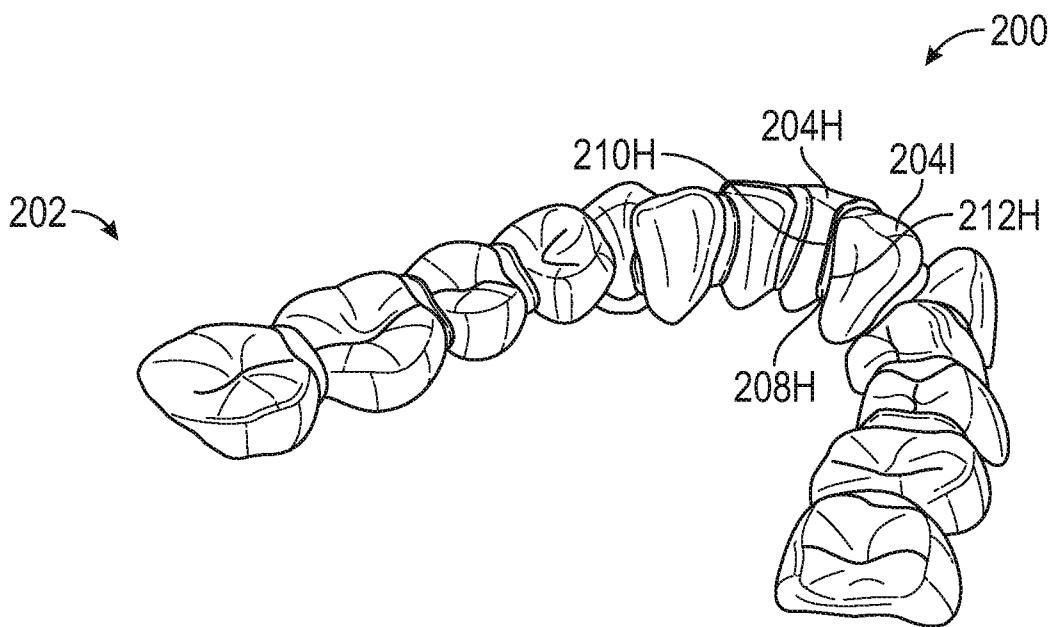

FIG. 2G

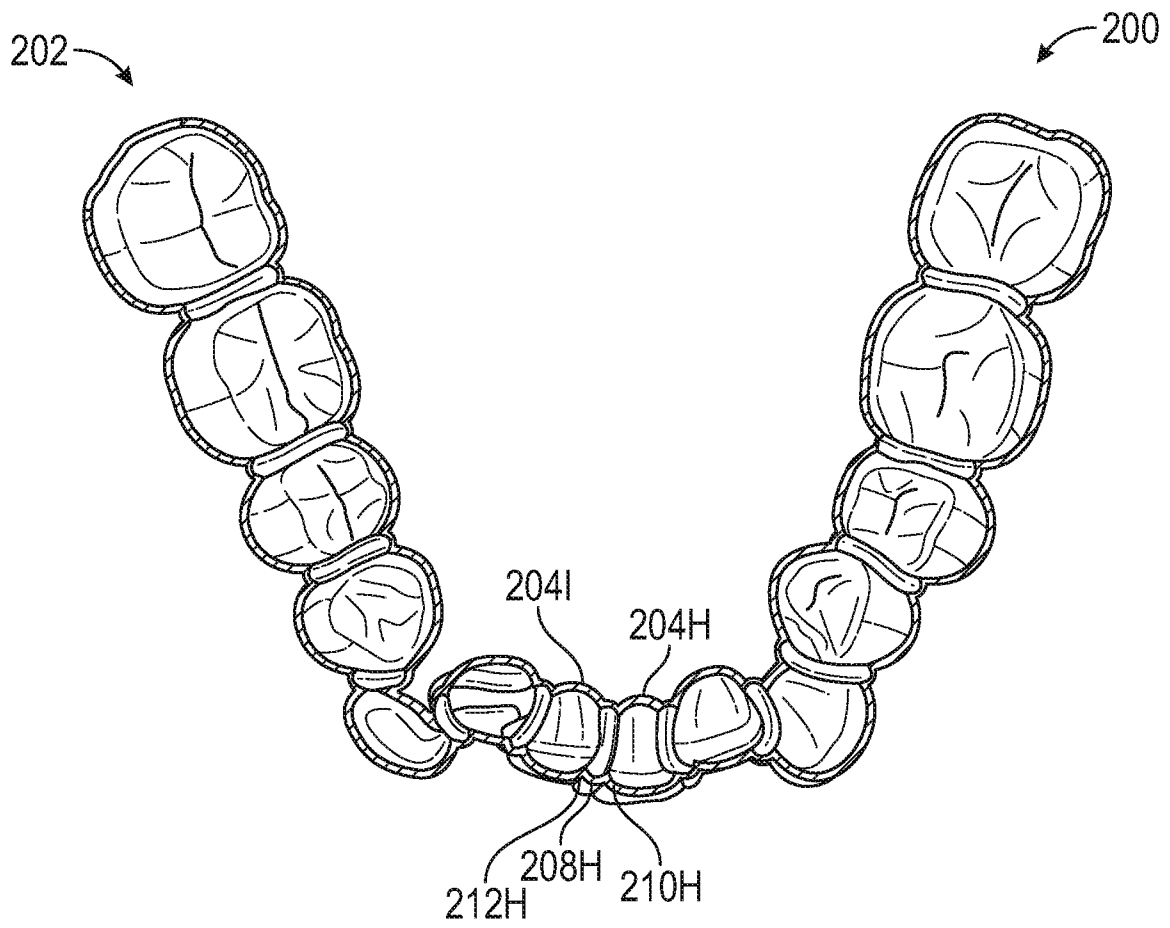

FIG. 2H

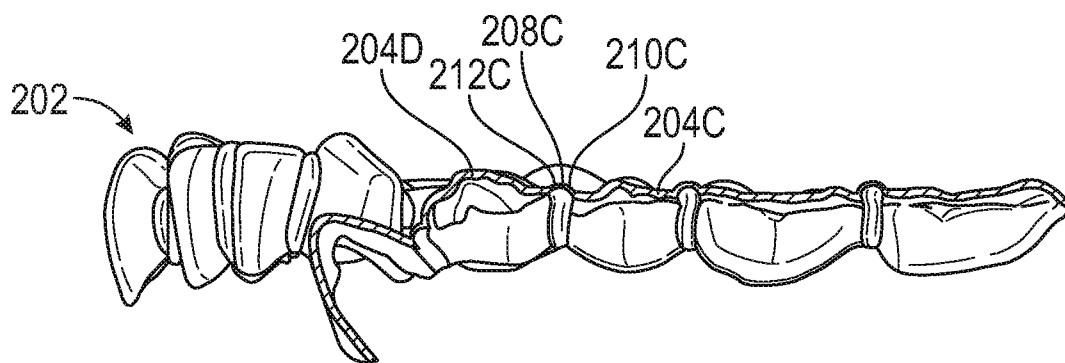

FIG. 2I

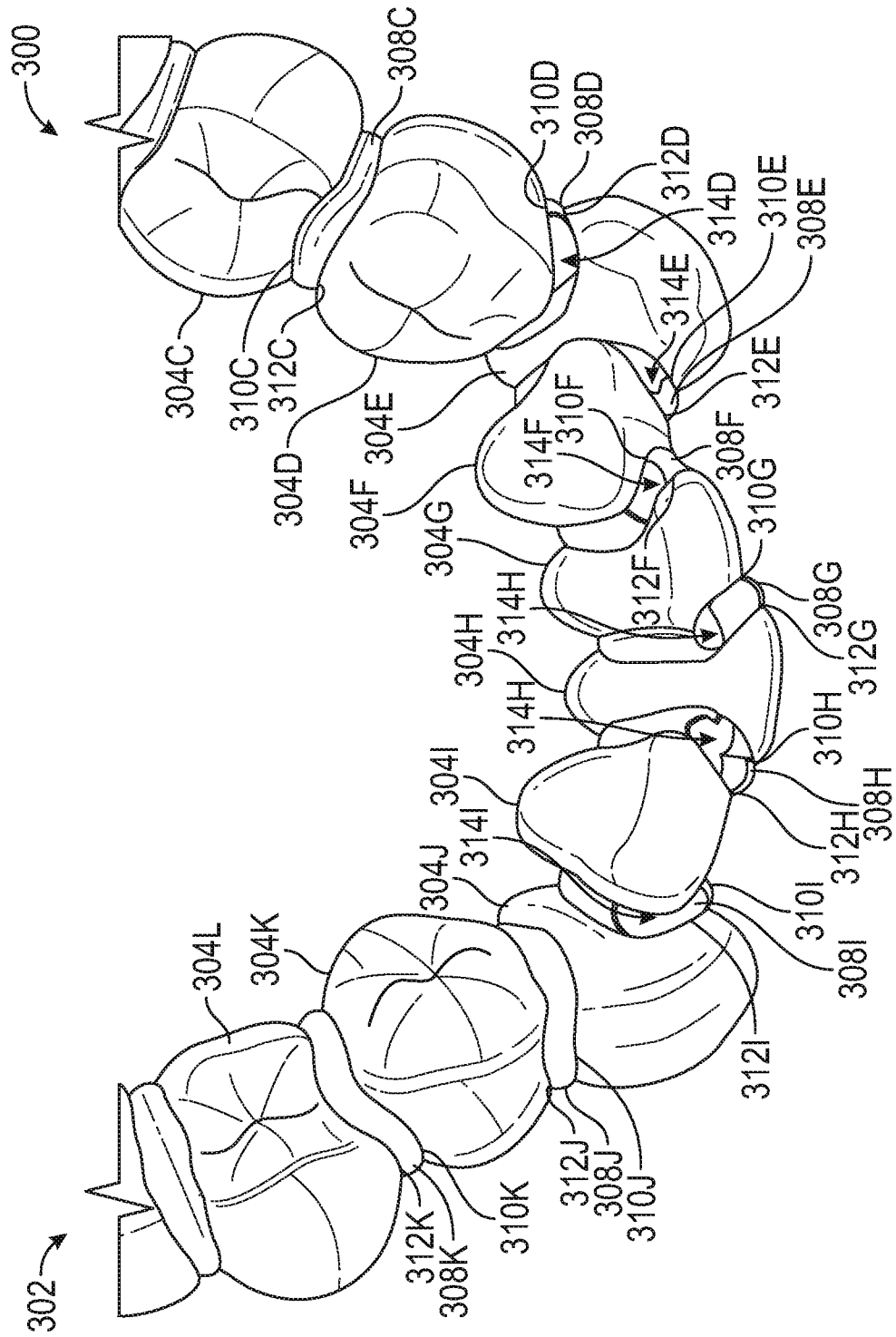

FIG. 3A

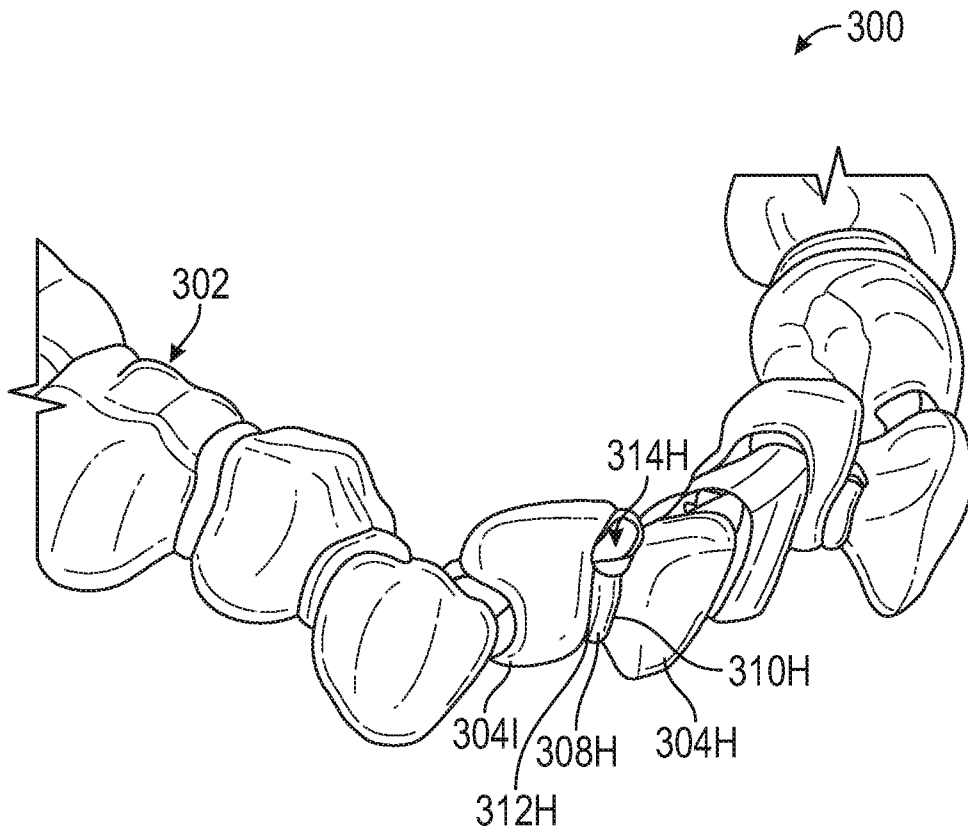

FIG. 3B

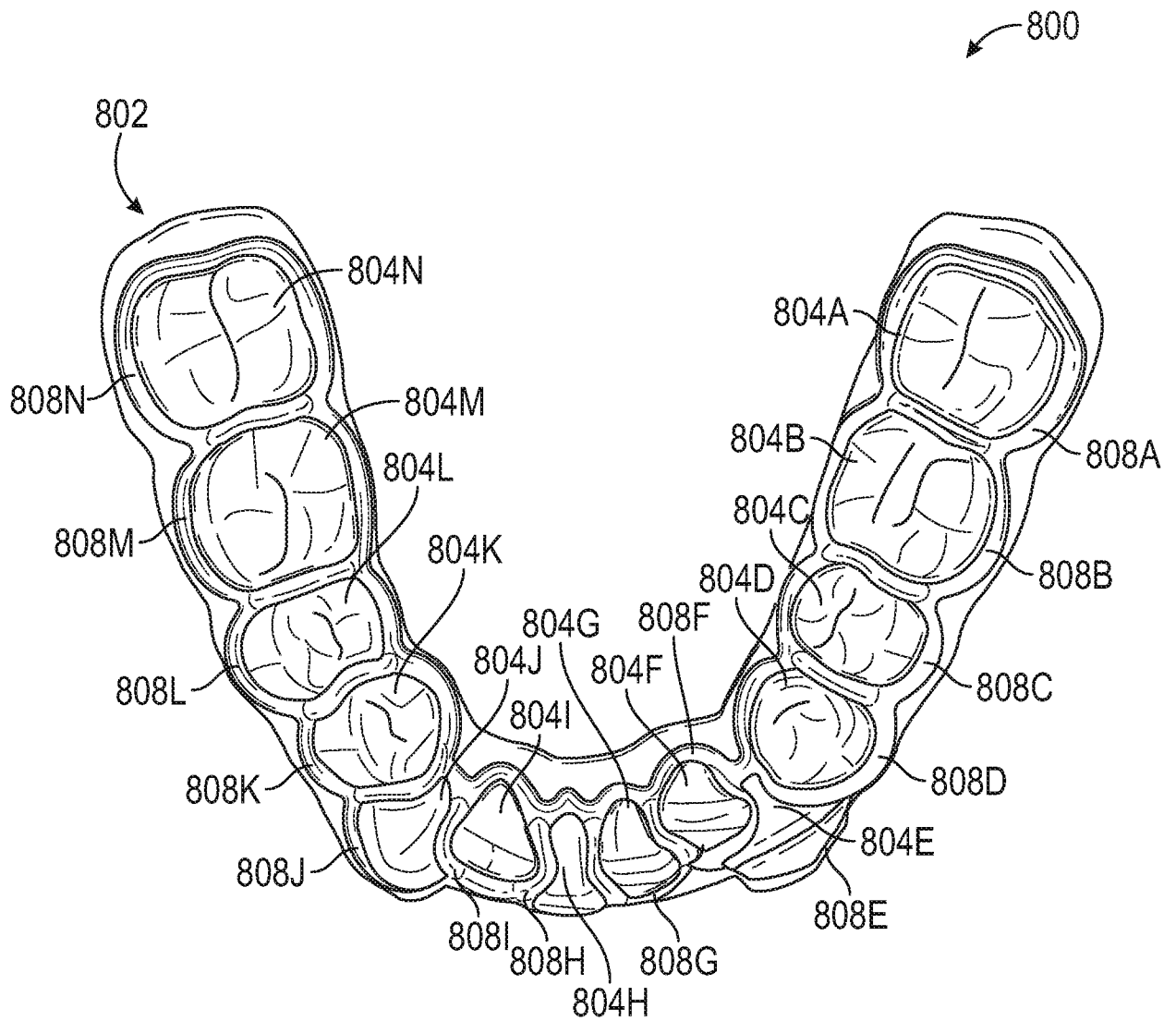

FIG. 4

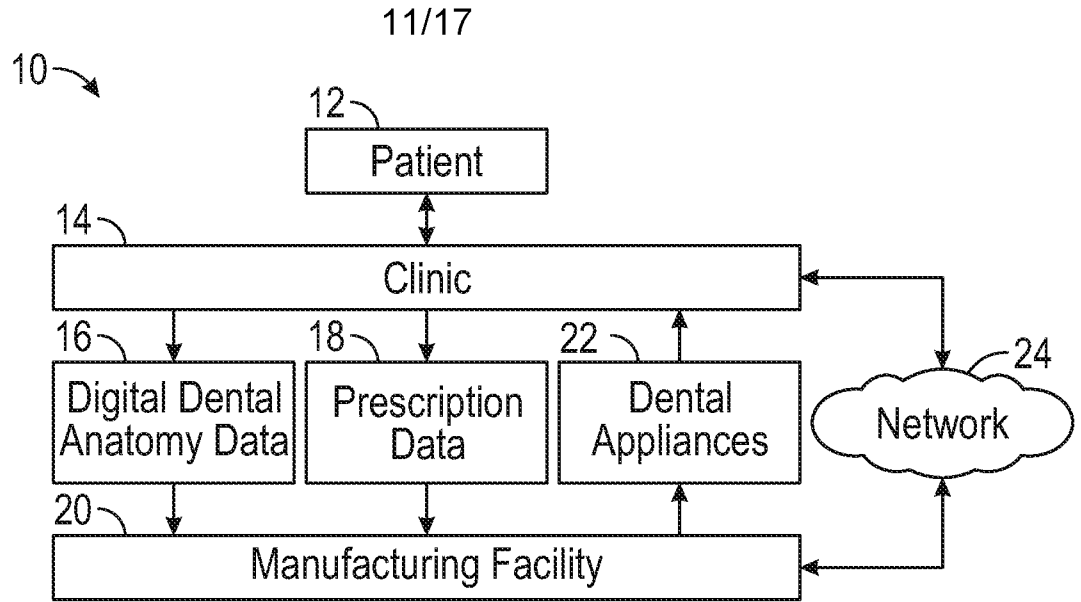

FIG. 5

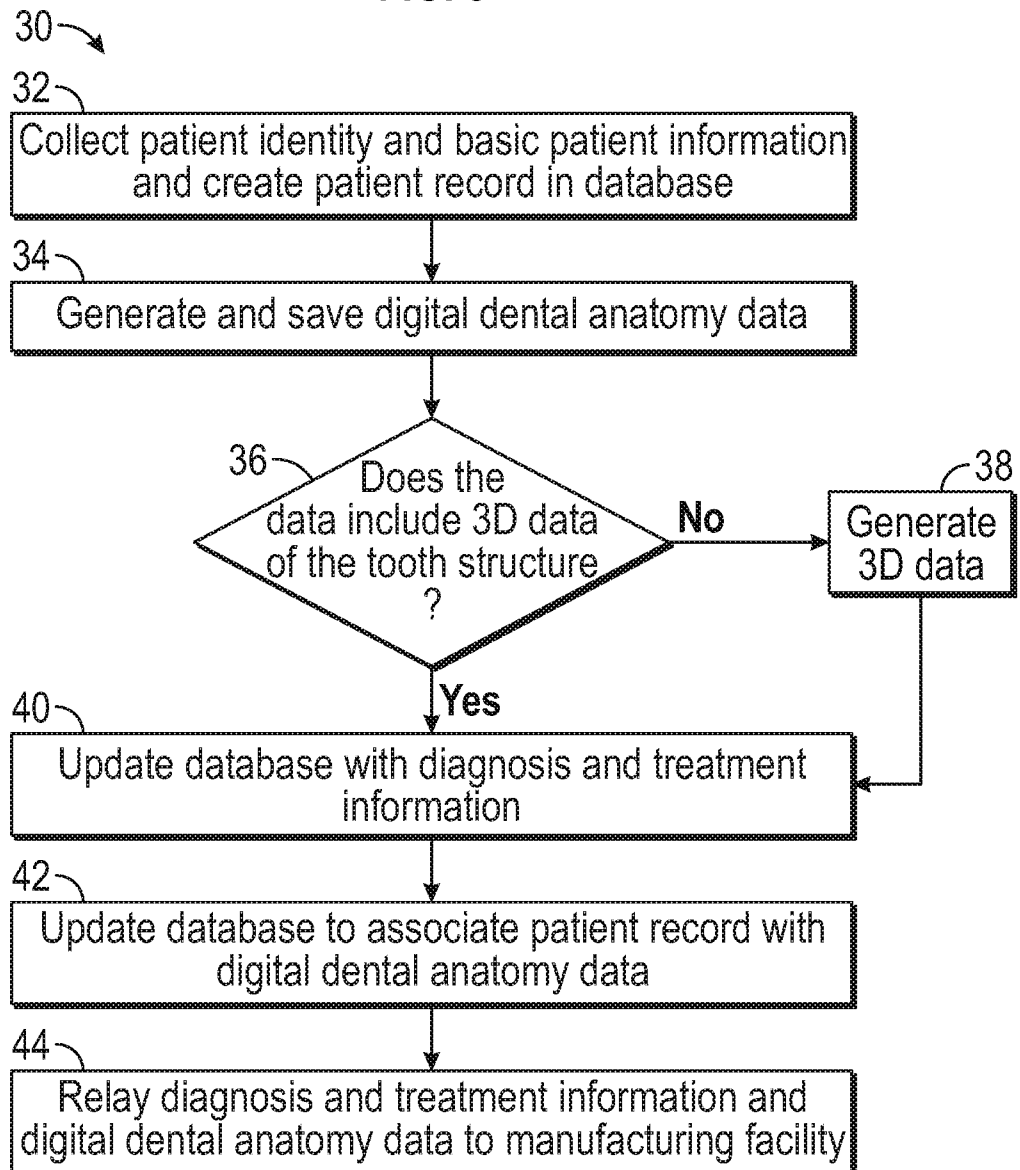

FIG. 6

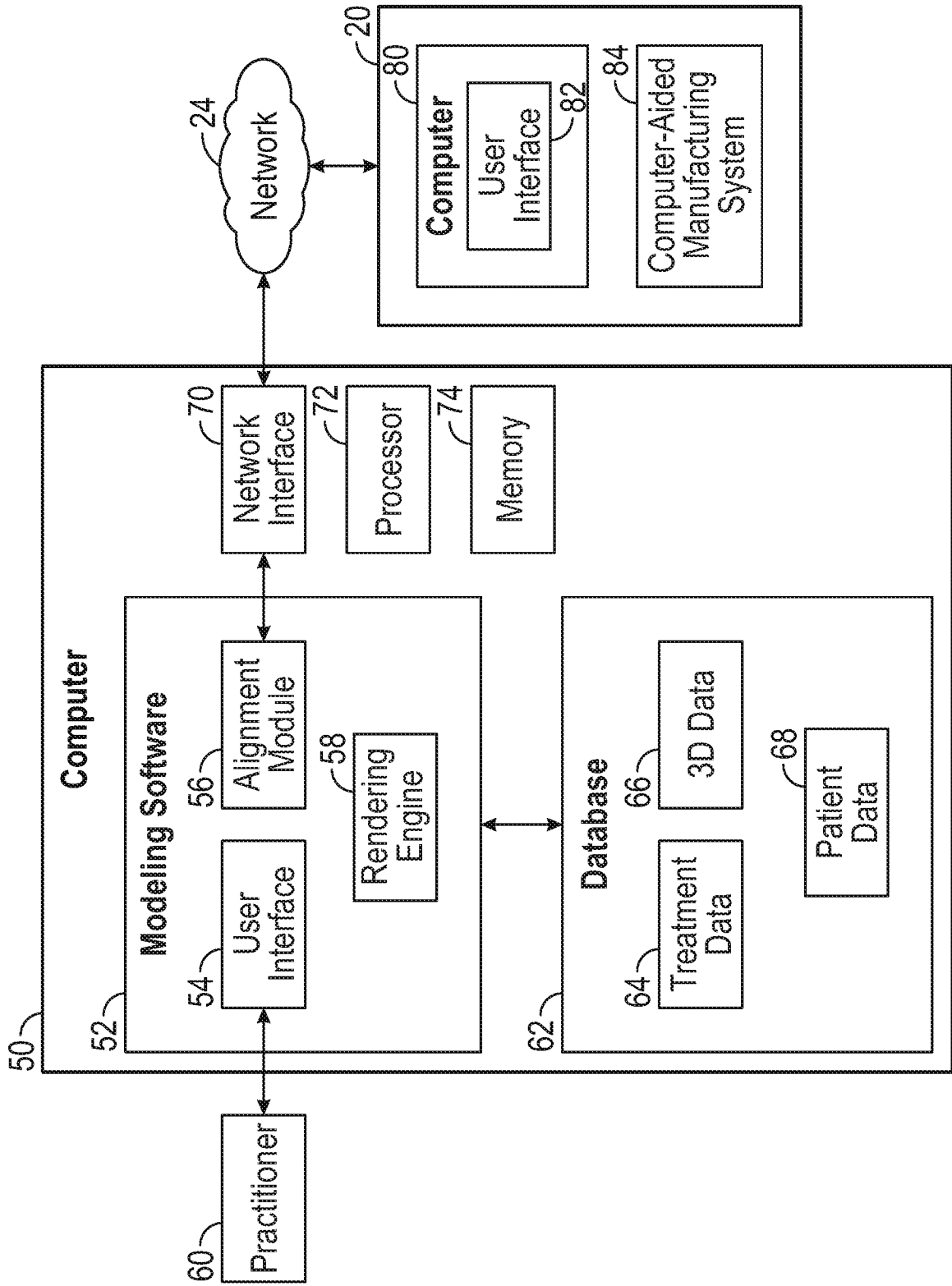

FIG. 7

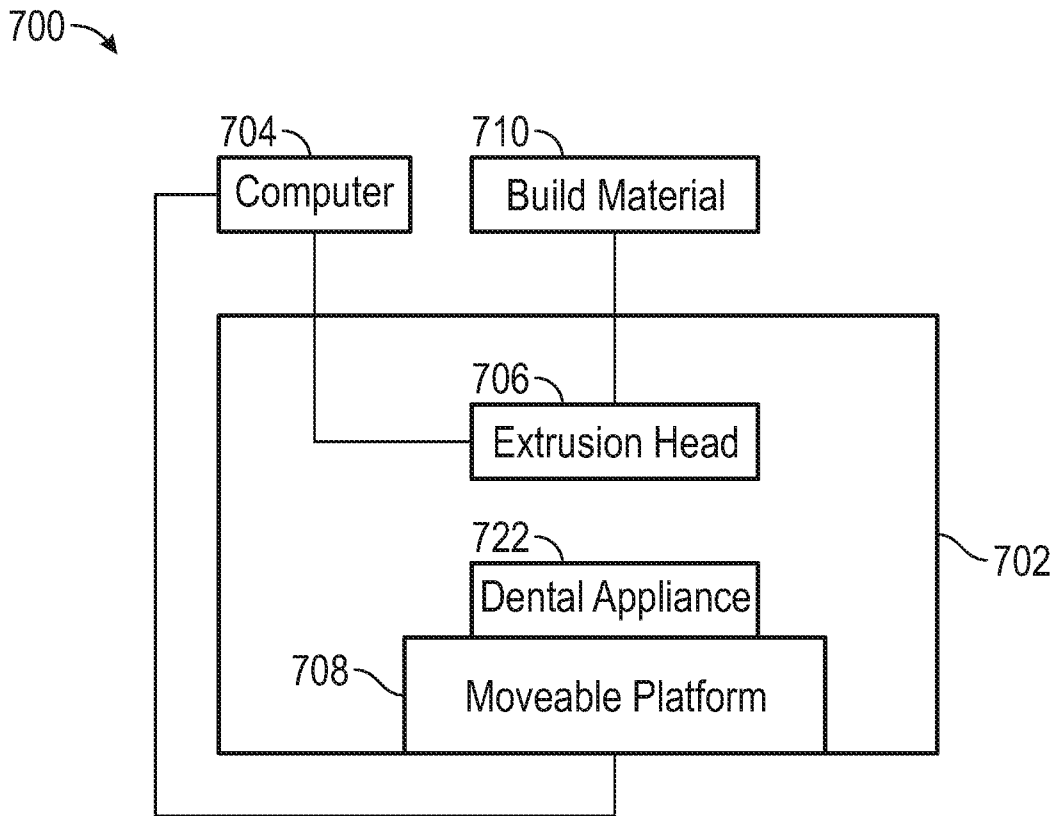

FIG. 8

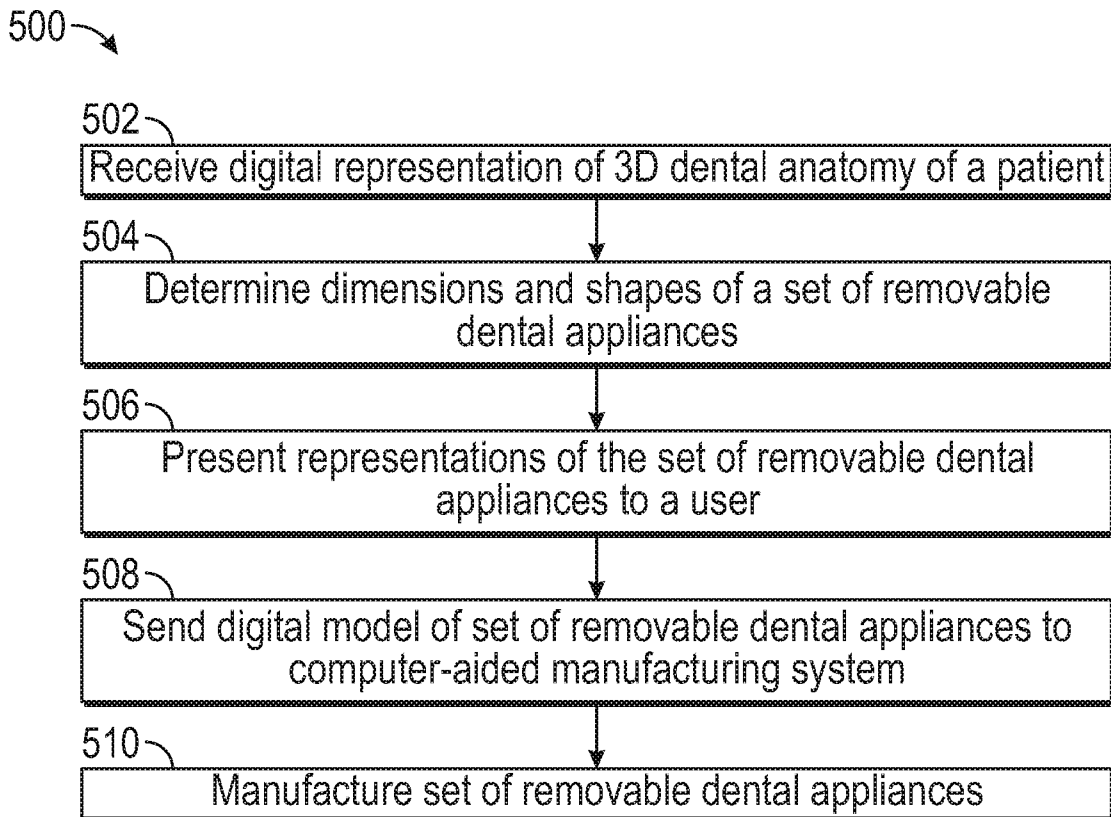

FIG. 9

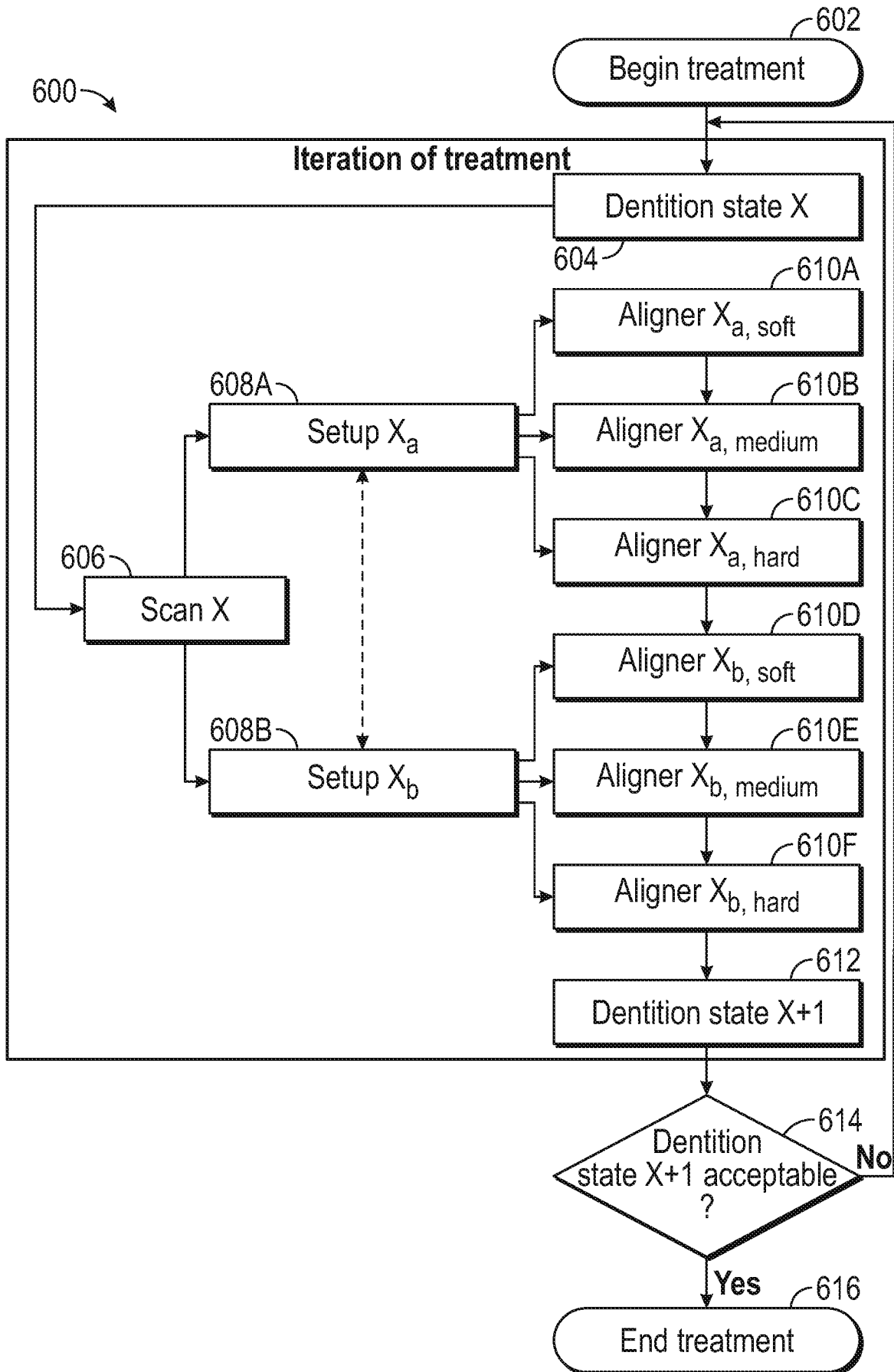

FIG. 10

A: Static Structural
Directional Deformation
Type: Directional Deformation(Z Axis)
Unit: mm
Global Coordinate System

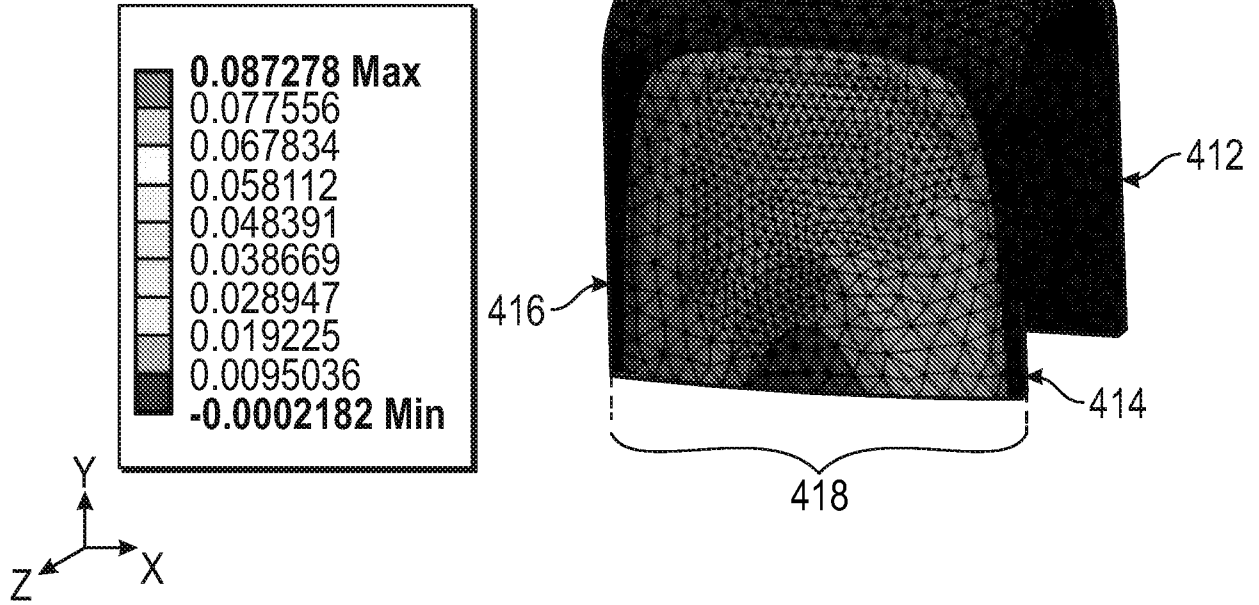

FIG. 11A

A: Static Structural
Equivalent Stress
Type: Equivalent (von-Mises) Stress
Unit: MPa

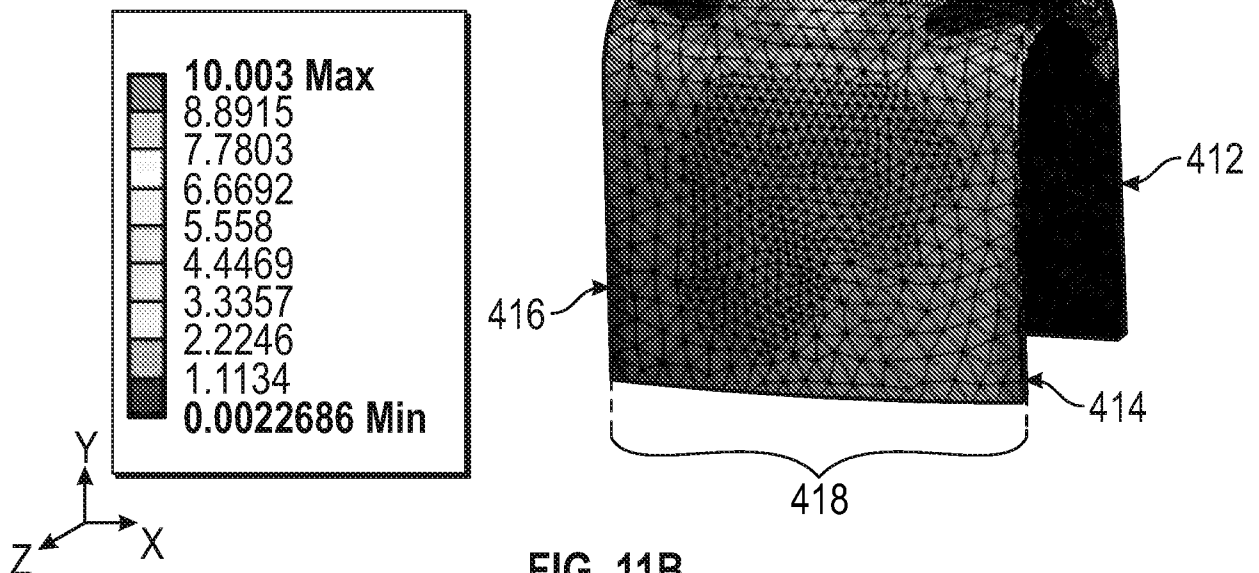
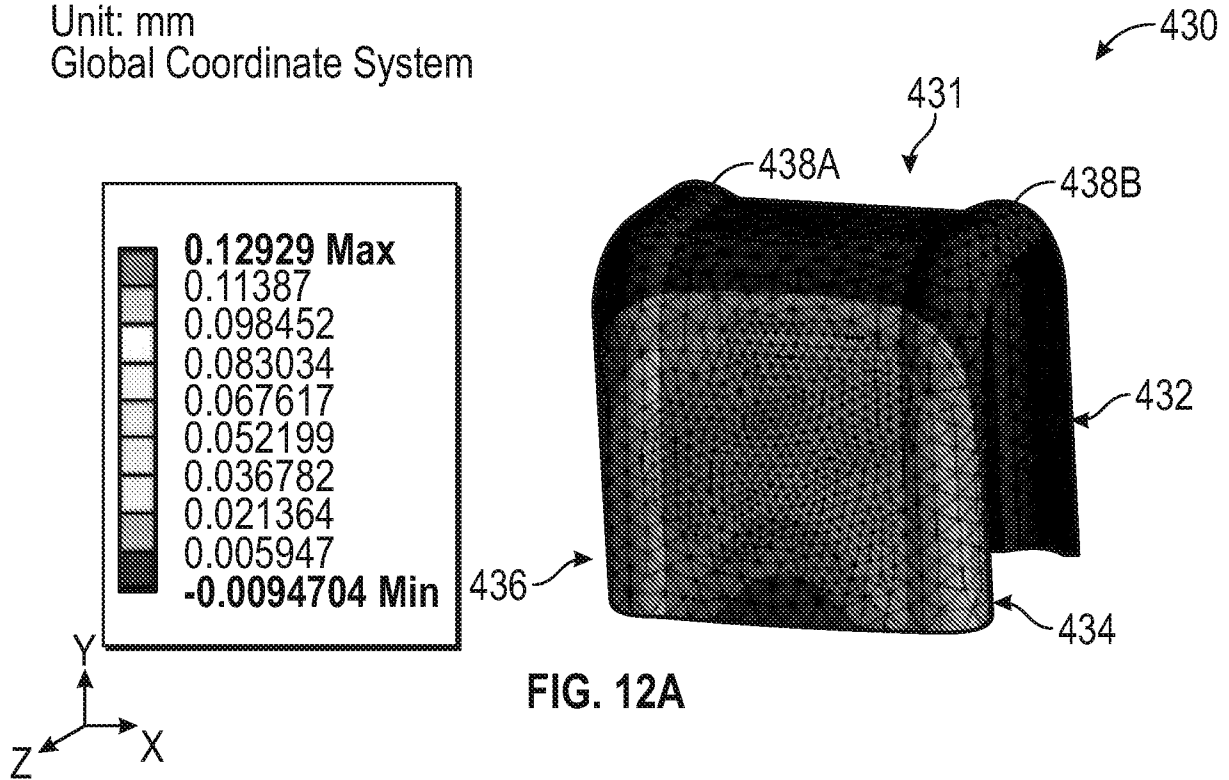
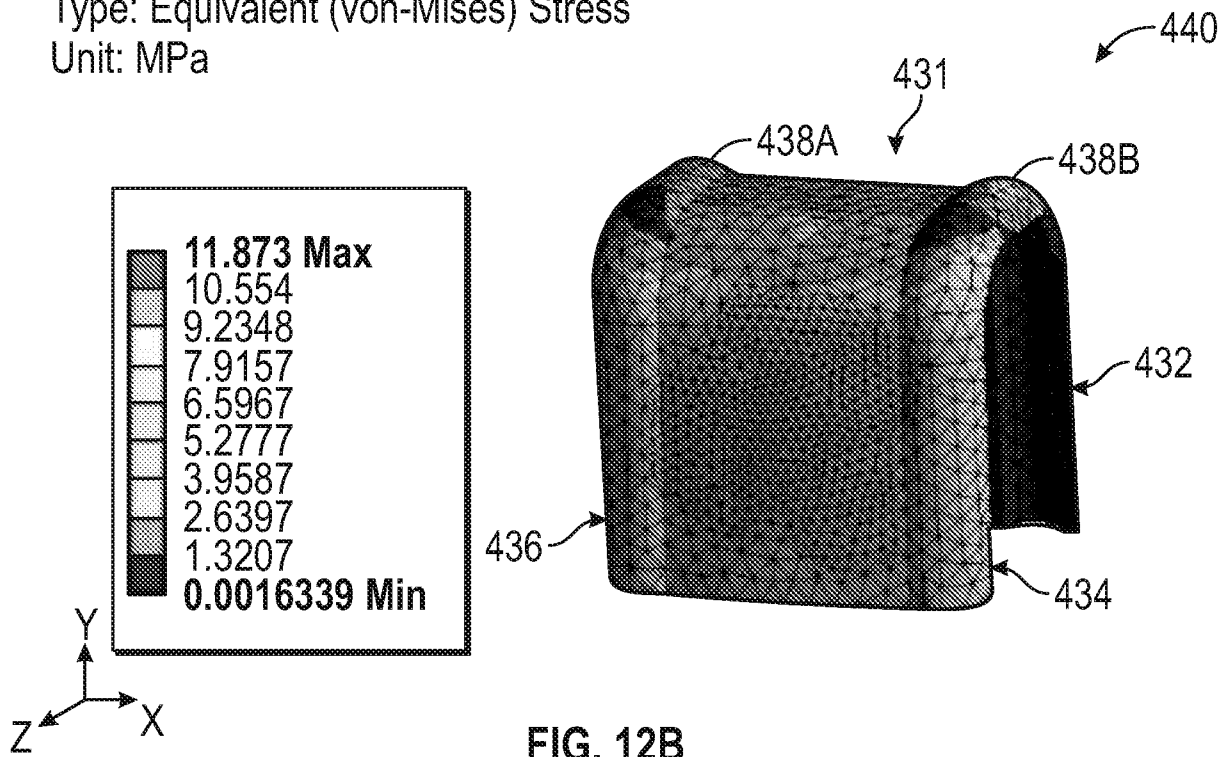

FIG. 11B

A: Static Structural
Directional Deformation
Type: Directional Deformation(Z Axis)
Unit: mm
Global Coordinate System



A: Static Structural
Equivalent Stress
Type: Equivalent (von-Mises) Stress
Unit: MPa



A: Static Structural

Directional Deformation

Type: Directional Deformation(Z Axis)

Unit: mm

Global Coordinate System

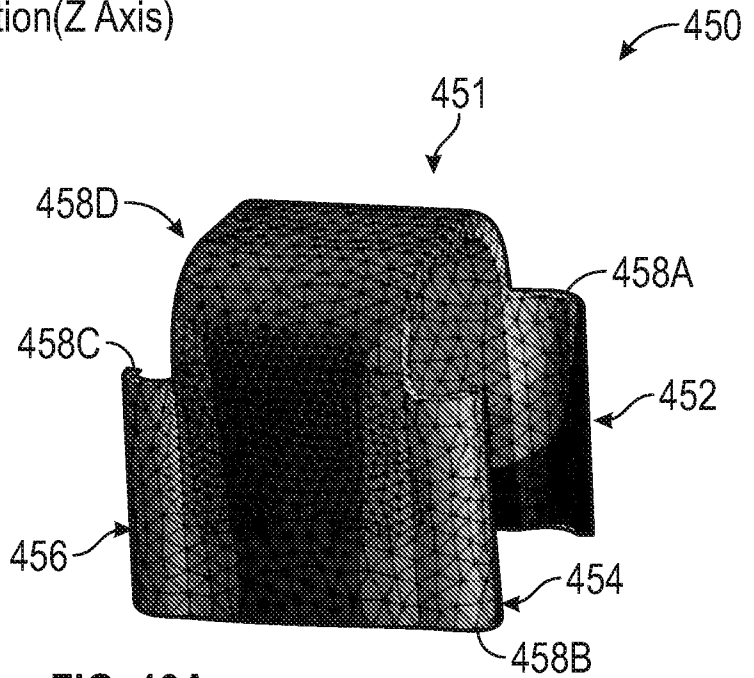
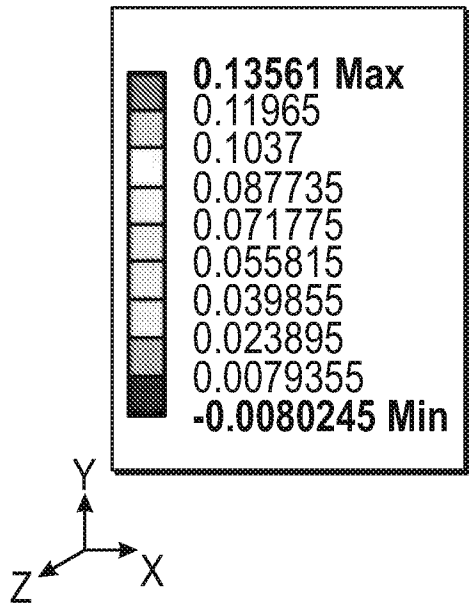

FIG. 13A

A: Static Structural

Equivalent Stress

Type: Equivalent (von-Mises) Stress

Unit: MPa

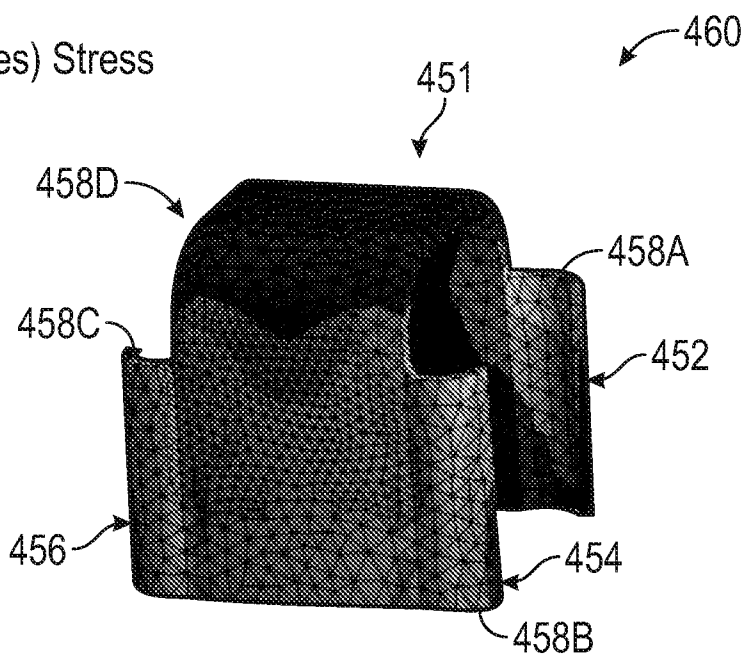
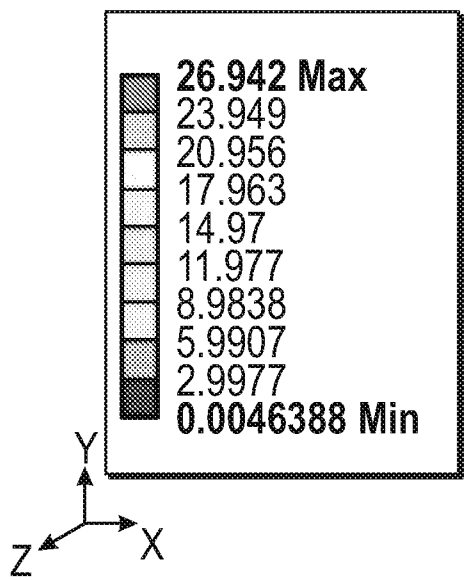

FIG. 13B

INTERNATIONAL SEARCH REPORT

International application No.
PCT/IB2018/057159**A. CLASSIFICATION OF SUBJECT MATTER****A61C 7/08(2006.01)i, A61C 7/00(2006.01)i, A61C 9/00(2006.01)i**

According to International Patent Classification (IPC) or to both national classification and IPC

B. FIELDS SEARCHEDMinimum documentation searched (classification system followed by classification symbols)
A61C 7/08; A61C 7/00; A61C 7/06; A61C 7/16; B33Y 80/00; A61C 9/00Documentation searched other than minimum documentation to the extent that such documents are included in the fields searched
Korean utility models and applications for utility models
Japanese utility models and applications for utility modelsElectronic data base consulted during the international search (name of data base and, where practicable, search terms used)
eKOMPASS(KIPO internal) & Keywords:dental appliance, first shell, second shell, spring bellows**C. DOCUMENTS CONSIDERED TO BE RELEVANT**

Category*	Citation of document, with indication, where appropriate, of the relevant passages	Relevant to claim No.
X	WO 2015-140614 A1 (ALIGN TECHNOLOGY, INC.) 24 September 2015 See abstract; paragraphs [0031]-[0040], [0055]-[0059]; claims 1-30; and figures 1A-9.	1-3, 18-20, 35-37 , 52-54
A	US 2017-0065373 A1 (MARTZ, M. G. et al.) 09 March 2017 See the whole document.	1-3, 18-20, 35-37 , 52-54
A	US 2015-0157421 A1 (MARTZ, M.G. et al.) 11 June 2015 See the whole document.	1-3, 18-20, 35-37 , 52-54
A	KR 10-2015-0119597 A (KIM, C. H.) 26 October 2015 See the whole document.	1-3, 18-20, 35-37 , 52-54
A	US 6572372 B1 (PHAN, L. X. et al.) 03 June 2003 See the whole document.	1-3, 18-20, 35-37 , 52-54

 Further documents are listed in the continuation of Box C. See patent family annex.

* Special categories of cited documents:

"A" document defining the general state of the art which is not considered to be of particular relevance

"E" earlier application or patent but published on or after the international filing date

"L" document which may throw doubts on priority claim(s) or which is cited to establish the publication date of another citation or other special reason (as specified)

"O" document referring to an oral disclosure, use, exhibition or other means

"P" document published prior to the international filing date but later than the priority date claimed

"T" later document published after the international filing date or priority date and not in conflict with the application but cited to understand the principle or theory underlying the invention

"X" document of particular relevance; the claimed invention cannot be considered novel or cannot be considered to involve an inventive step when the document is taken alone

"Y" document of particular relevance; the claimed invention cannot be considered to involve an inventive step when the document is combined with one or more other such documents, such combination being obvious to a person skilled in the art

"&" document member of the same patent family

Date of the actual completion of the international search

19 February 2019 (19.02.2019)

Date of mailing of the international search report

20 February 2019 (20.02.2019)

Name and mailing address of the ISA/KR

International Application Division
Korean Intellectual Property Office
189 Cheongsa-ro, Seo-gu, Daejeon, 35208, Republic of Korea

Facsimile No. +82-42-481-8578

Authorized officer

HAN, Inho

Telephone No. +82-42-481-3362



Box No. II Observations where certain claims were found unsearchable (Continuation of item 2 of first sheet)

This international search report has not been established in respect of certain claims under Article 17(2)(a) for the following reasons:

1. Claims Nos.:
because they relate to subject matter not required to be searched by this Authority, namely:

2. Claims Nos.: 9, 10, 14, 15, 26, 27, 31, 32, 43, 44, 48, 49, 59, 64, 68
because they relate to parts of the international application that do not comply with the prescribed requirements to such an extent that no meaningful international search can be carried out, specifically:
Each of claims 9, 10, 14, 15, 26, 27, 31, 32, 43, 44, 48, 49, 59 and 64 refers to a claim which is not drafted in accordance with the third sentence of Rule 6.4(a).
Claim 52 relates to a method, but claim 68 dependant on claim 52 relate to the removable dental appliance. Claim 68 does not clearly define the matter for which protection is sought.
3. Claims Nos.: 4-8, 11-13, 16, 17, 21-25, 28-30, 33, 34, 38-42, 45-47, 50, 51, 55-58, 60-63, 65-71
because they are dependent claims and are not drafted in accordance with the second and third sentences of Rule 6.4(a).

Box No. III Observations where unity of invention is lacking (Continuation of item 3 of first sheet)

This International Searching Authority found multiple inventions in this international application, as follows:

1. As all required additional search fees were timely paid by the applicant, this international search report covers all searchable claims.
2. As all searchable claims could be searched without effort justifying an additional fees, this Authority did not invite payment of any additional fees.
3. As only some of the required additional search fees were timely paid by the applicant, this international search report covers only those claims for which fees were paid, specifically claims Nos.:

4. No required additional search fees were timely paid by the applicant. Consequently, this international search report is restricted to the invention first mentioned in the claims; it is covered by claims Nos.:

Remark on Protest

- The additional search fees were accompanied by the applicant's protest and, where applicable, the payment of a protest fee.
- The additional search fees were accompanied by the applicant's protest but the applicable protest fee was not paid within the time limit specified in the invitation.
- No protest accompanied the payment of additional search fees.

INTERNATIONAL SEARCH REPORT

Information on patent family members

International application No.

PCT/IB2018/057159

Patent document cited in search report	Publication date	Patent family member(s)	Publication date		
WO 2015-140614 A1	24/09/2015	CN 106029001 A	12/10/2016		
		CN 106413623 A	15/02/2017		
		CN 106572894 A	19/04/2017		
		CN 106572895 A	19/04/2017		
		EP 3099266 A1	07/12/2016		
		EP 3119347 A1	25/01/2017		
		EP 3157458 A1	26/04/2017		
		EP 3157459 A1	26/04/2017		
		JP 2017-505181 A	16/02/2017		
		JP 6422502 B2	14/11/2018		
		US 2015-0216627 A1	06/08/2015		
		US 2015-0265376 A1	24/09/2015		
		US 2015-0366637 A1	24/12/2015		
		US 2015-0366638 A1	24/12/2015		
		US 2016-0310236 A1	27/10/2016		
		WO 2015-114450 A1	06/08/2015		
		WO 2015-193709 A1	23/12/2015		
		WO 2015-193710 A1	23/12/2015		
		US 2017-0065373 A1	09/03/2017	AU 2016-321226 A1	26/04/2018
				CN 108495597 A	04/09/2018
EP 3346941 A1	18/07/2018				
KR 10-2018-0073567 A	02/07/2018				
WO 2017-044631 A1	16/03/2017				
US 2015-0157421 A1	11/06/2015	US 2018-0214250 A1	02/08/2018		
		US 9937018 B2	10/04/2018		
KR 10-2015-0119597 A	26/10/2015	KR 10-1638329 B1	11/07/2016		
US 6572372 B1	03/06/2003	AU 1108000 A	26/04/2000		
		AU 1108100 A	26/04/2000		
		AU 1444100 A	26/04/2000		
		AU 1634700 A	19/06/2000		
		AU 2003-100613 A4	21/08/2003		
		AU 2003-100613 B4	30/09/2004		
		AU 2005-201222 A1	14/04/2005		
		AU 2005-201222 B2	08/01/2009		
		AU 2008-227067 A1	23/10/2008		
		AU 2008-227067 B2	01/09/2011		
		AU 2011-253781 A1	12/01/2012		
		AU 2011-253781 A8	15/01/2015		
		AU 2011-253781 B2	21/08/2014		
		AU 2011-253781 B8	15/01/2015		
		AU 3104600 A	19/06/2000		
		AU 5131000 A	05/12/2000		
		AU 5508300 A	30/11/2000		
AU 5563701 A	07/11/2001				
AU 5565701 A	07/11/2001				

INTERNATIONAL SEARCH REPORT

Information on patent family members

International application No.

PCT/IB2018/057159

Patent document cited in search report	Publication date	Patent family member(s)	Publication date
		AU 6420399 A	26/04/2000
		AU 6422999 A	26/04/2000
		AU 6512799 A	26/04/2000
		AU 6513099 A	05/12/2000
		AU 726743 B2	16/11/2000
		AU 744385 B2	21/02/2002
		AU 779176 B2	13/01/2005
		AU 8156498 A	04/01/1999
		AU 9730201 A	14/02/2002
		CN 101006940 A	01/08/2007
		CN 101006940 B	23/01/2013
		CN 101006941 A	01/08/2007
		CN 101006941 B	01/12/2010
		CN 101006942 A	01/08/2007
		CN 101006942 B	21/04/2010
		CN 101006943 A	01/08/2007
		CN 101006943 B	08/09/2010
		CN 101011295 A	08/08/2007
		CN 101011295 B	06/03/2013
		CN 102088925 A	08/06/2011
		CN 107693136 A	16/02/2018
		CN 1260698 A	19/07/2000
		CN 1307947 C	04/04/2007
		EP 0989828 A1	05/04/2000
		EP 0989828 B1	10/09/2003
		EP 1119308 A1	01/08/2001
		EP 1119308 B1	22/08/2007
		EP 1119309 A1	01/08/2001
		EP 1119309 B1	01/06/2016
		EP 1119312 A1	01/08/2001
		EP 1119312 B1	25/06/2008
		EP 1143872 A1	17/10/2001
		EP 1143872 B1	10/08/2011
		EP 1146832 A1	24/10/2001
		EP 1146832 B1	12/11/2008
		EP 1178760 A1	13/02/2002
		EP 1178760 B1	13/01/2010
		EP 1191896 A1	03/04/2002
		EP 1191896 B1	25/06/2008
		EP 1191897 A1	03/04/2002
		EP 1191897 B1	11/03/2009
		EP 1274363 A1	15/01/2003
		EP 1274363 B1	07/09/2016
		EP 1286627 A2	05/03/2003
		EP 1286627 B1	26/10/2016
		EP 1369091 A1	10/12/2003
		EP 1369091 B1	14/10/2009
		EP 1929974 A2	11/06/2008
		EP 1929974 A3	23/03/2011
		EP 2002797 A2	17/12/2008

INTERNATIONAL SEARCH REPORT

Information on patent family members

International application No.

PCT/IB2018/057159

Patent document cited in search report	Publication date	Patent family member(s)	Publication date
		EP 2002797 A3	04/03/2009
		EP 2026285 A1	18/02/2009
		EP 2026285 B1	05/10/2016
		EP 2263598 A1	22/12/2010
		EP 2263598 B1	25/05/2011
		EP 2263598 B2	02/08/2017
		EP 2263599 A1	22/12/2010
		EP 2263599 B1	27/04/2011
		EP 2263599 B2	03/01/2018
		EP 2266491 A1	29/12/2010
		EP 2266493 A2	29/12/2010
		EP 2266493 A3	18/05/2011
		EP 2289458 A2	02/03/2011
		EP 2289458 A3	01/07/2015
		EP 2295003 A1	16/03/2011
		EP 2295003 B1	27/04/2016
		EP 2295004 A1	16/03/2011
		EP 2295004 B1	22/02/2012
		EP 2295005 A1	16/03/2011
		EP 2295005 B1	19/10/2016
		EP 2298227 A1	23/03/2011
		EP 2309944 A2	20/04/2011
		JP 2002-514125 A	14/05/2002
		JP 2002-526153 A	20/08/2002
		JP 2002-526154 A	20/08/2002
		JP 2002-526155 A	20/08/2002
		JP 2002-531166 A	24/09/2002
		JP 2002-531167 A	24/09/2002
		JP 2002-543918 A	24/12/2002
		JP 2003-521014 A	08/07/2003
		JP 2004-243141 A	02/09/2004
		JP 2004-255205 A	16/09/2004
		JP 2004-267790 A	30/09/2004
		JP 2004-500149 A	08/01/2004
		JP 2004-507281 A	11/03/2004
		JP 2004-515261 A	27/05/2004
		JP 2005-021714 A	27/01/2005
		JP 2005-118592 A	12/05/2005
		JP 2005-144190 A	09/06/2005
		JP 2005-161048 A	23/06/2005
		JP 2005-161049 A	23/06/2005
		JP 2005-161081 A	23/06/2005
		JP 2005-224599 A	25/08/2005
		JP 2007-167685 A	05/07/2007
		JP 2007-181717 A	19/07/2007
		JP 2007-190402 A	02/08/2007
		JP 2007-203085 A	16/08/2007
		JP 2007-330823 A	27/12/2007
		JP 2008-018253 A	31/01/2008
		JP 2008-068113 A	27/03/2008

INTERNATIONAL SEARCH REPORT

Information on patent family members

International application No.

PCT/IB2018/057159

Patent document cited in search report	Publication date	Patent family member(s)	Publication date
		JP 2008-178727 A	07/08/2008
		JP 2008-212698 A	18/09/2008
		JP 2009-000555 A	08/01/2009
		JP 2009-006161 A	15/01/2009
		JP 2009-050723 A	12/03/2009
		JP 2009-101192 A	14/05/2009
		JP 2009-178573 A	13/08/2009
		JP 2009-297525 A	24/12/2009
		JP 2010-188178 A	02/09/2010
		JP 2011-087963 A	06/05/2011
		JP 2011-087964 A	06/05/2011
		JP 2011-235178 A	24/11/2011
		JP 2011-240203 A	01/12/2011
		JP 2012-096052 A	24/05/2012
		JP 2014-012184 A	23/01/2014
		JP 2014-144357 A	14/08/2014
		JP 2016-034592 A	17/03/2016
		JP 3618082 B2	09/02/2005
		JP 3620048 B2	16/02/2005
		JP 3630634 B2	16/03/2005
		JP 3636660 B2	06/04/2005
		JP 3636661 B2	06/04/2005
		JP 3636662 B2	06/04/2005
		JP 3641208 B2	20/04/2005
		JP 3657197 B2	08/06/2005
		JP 4134009 B2	13/08/2008
		JP 4459699 B2	28/04/2010
		JP 4756717 B2	24/08/2011
		JP 4824062 B2	24/11/2011
		JP 4878121 B2	15/02/2012
		JP 4883699 B2	22/02/2012
		JP 4927602 B2	09/05/2012
		JP 4928396 B2	09/05/2012
		JP 4963280 B2	27/06/2012
		JP 5014060 B2	29/08/2012
		JP 5131978 B2	30/01/2013
		JP 5188250 B2	24/04/2013
		JP 5425054 B2	26/02/2014
		JP 5567907 B2	06/08/2014
		JP 6005680 B2	12/10/2016
		US 2003-0190576 A1	09/10/2003
		US 2004-0170941 A1	02/09/2004
		US 2006-0008760 A1	12/01/2006
		US 2007-0231765 A1	04/10/2007
		US 2008-0020337 A1	24/01/2008
		US 2012-0015314 A1	19/01/2012
		US 6964564 B2	15/11/2005
		US 8235713 B2	07/08/2012