

May 29, 1962

N. S. CLAY

3,036,306

STAPLER DEVICE OR MACHINE

Filed Aug. 4, 1960

2 Sheets-Sheet 1

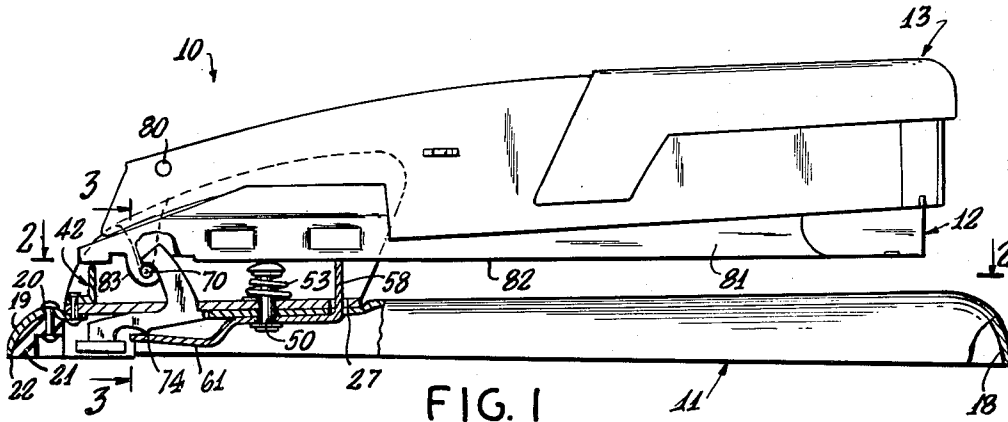

FIG. 1

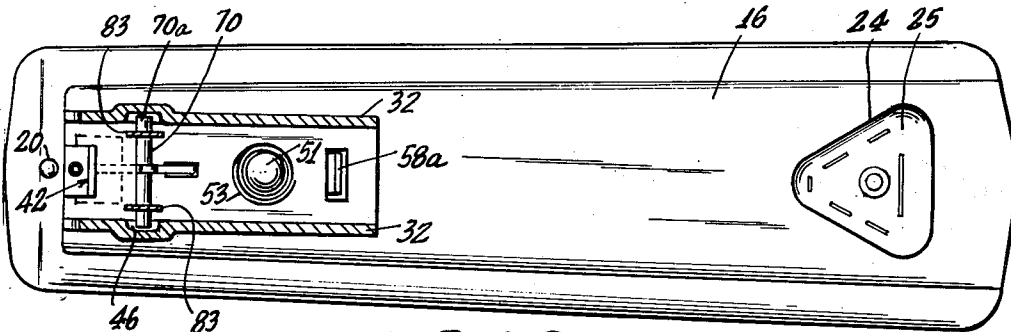

FIG. 2

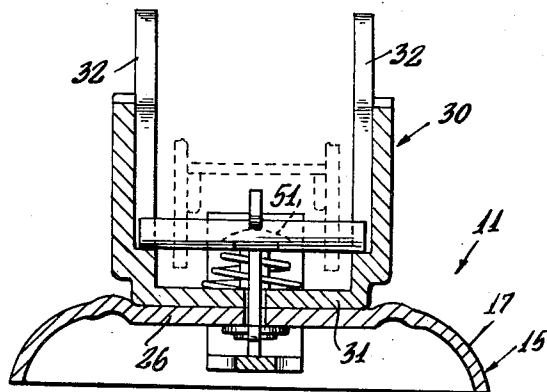

FIG. 3

INVENTOR.
NATHAN S. CLAY

BY

J. B. Felsher
ATTORNEY.

May 29, 1962

N. S. CLAY

3,036,306

STAPLER DEVICE OR MACHINE

Filed Aug. 4, 1960

2 Sheets-Sheet 2

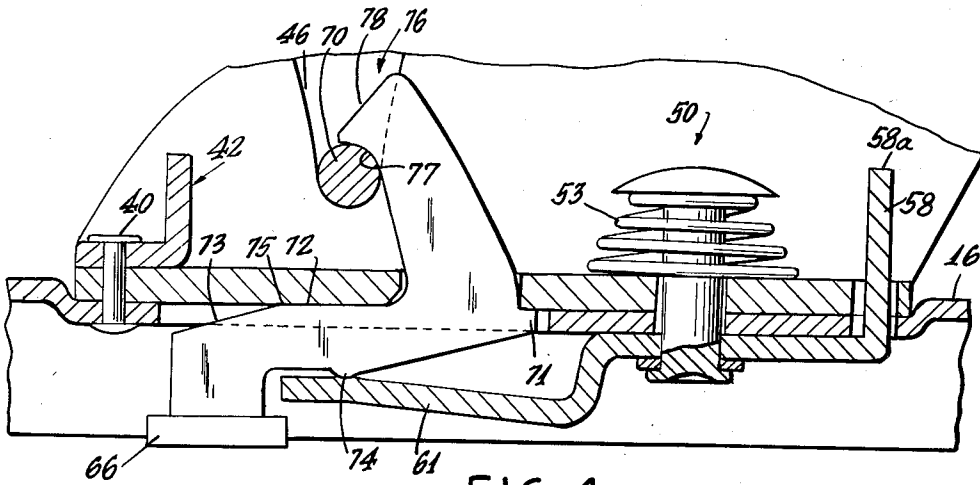

FIG. 4

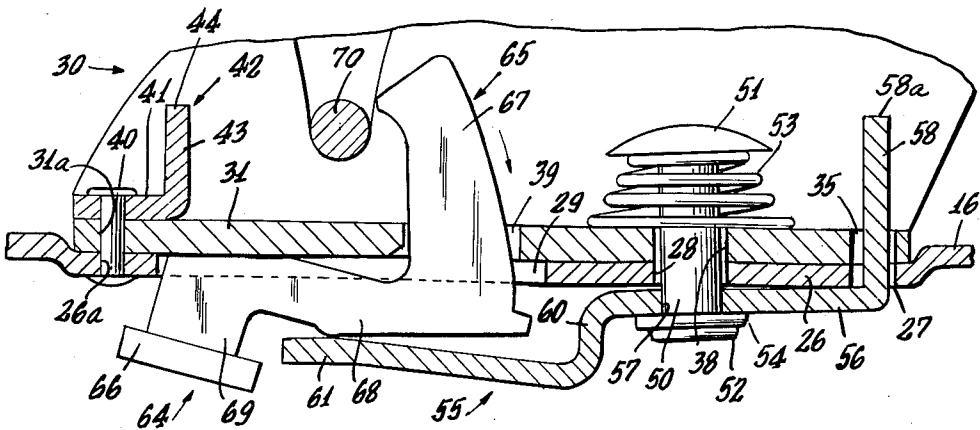

FIG. 5

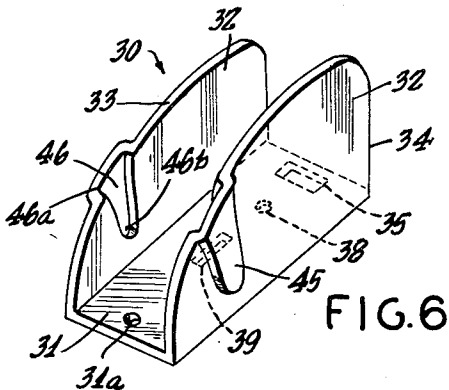

FIG. 6

INVENTOR.
NATHAN S. CLAY

BY

J. B. Felscher
ATTORNEY

1

3,036,306

STAPLER DEVICE OR MACHINE

Nathan S. Clay, New York, N.Y., assignor to Arrow Fastener Co., Inc., Brooklyn, N.Y., a corporation of New York

Filed Aug. 4, 1960, Ser. No. 47,438
4 Claims. (Cl. 1-3)

This invention relates to stapler devices or machines.

Staplers often comprise a staple magazine and staple cover pivoted thereto and provided with plunger means to eject the staples, and means to removably and pivotally latch the interpivot magazine and cover to the base which carries an anvil, so that the magazine and cover may be used separately of the base, as a tacker. Users of such machines, as heretofore made, have had difficulty in connecting and disconnecting the interpivot magazine and cover from the base.

It is hence an object of this invention to provide a stapler of the character described provided with a highly improved releasable latch mechanism for pivotally connecting the interpivot magazine and cover, to the base; the construction being such that the latching and releasing of the magazine and cover may be easily and quickly accomplished without need for skill or study or strength, and by an extremely simple manipulation; the construction being such, furthermore, that when the magazine and cover are latched to the base, after each stapling operation, the magazine is pressed by a spring mechanism, back to a position parallel to and spaced above the base.

Another object of this invention is to provide a stapling machine of the character described in which the spring mechanism for moving the staple magazine back to parallel position relative to the base after a stapling operation, is utilized to retain the staple magazine and cover in latched condition on the base.

Yet another object of this invention is to provide in a stapling device of the character described, a pawl held in position latching a pivot pin on the staple magazine, by spring mechanism, and said pawl being provided with a button adapted to be pressed by a finger of the user to rotate the pawl against the pressure of said spring mechanism, to release the pivot pin and permit removal of the magazine and cover from the base; said device being provided further with means to guide the pivot pin to latching position, and said pawl having a finger provided with a latching hook to latch the pin on the magazine, and provided with cam means to permit the pivot pin to engage the cam means and rotate the pawl against pressure of the spring mechanism, as the pivot pin is moved toward latching position, until the pivot pin passes the hook of the finger, to permit the spring mechanism to snap the hook of the finger into latching engagement with the pivot pin.

Still another object of this invention is to provide a device of the character described in which the pawl is not mounted on any pivot pins, but is held in operative assembled relation to the device by a spring mechanism.

A further object of this invention is to provide a strong and rugged device of the character described, which shall be relatively inexpensive to manufacture, easy to manipulate, assemble and disassemble, and which shall yet be practical and efficient to a high degree in use.

Other objects of this invention will in part be obvious and in part hereinafter pointed out.

The invention accordingly consists in the features of construction, combinations of elements, and arrangement of parts which will be exemplified in the construction hereinafter described and of which the scope of invention will be indicated in the following claims.

2

In the accompanying drawings in which is shown an illustrative embodiment of this invention,

FIG. 1 is a side elevational view of a stapling device embodying the invention;

FIG. 2 is a cross-sectional view taken on line 2-2 of FIG. 1;

FIG. 3 is a cross-sectional view taken on line 3-3 of FIG. 1;

FIG. 4 is a vertical longitudinal cross-sectional view of the latching mechanism in latching position;

FIG. 5 is a view similar to FIG. 4, but showing the pawl pressed to releasing position; and

FIG. 6 is a perspective view of the base bracket for the stapling machine.

Referring now in detail to the drawing, 10 designates a stapler device embodying the invention.

The same comprises a base 11, a staple magazine 12 and a cover 13 provided with usual plunger means (not shown) for driving staples from the magazine.

The base 11 comprises a member 15 made of die stamped sheet metal or the like material. Said member 15 has a top wall 16 which slants somewhat forwardly and upwardly. Extending from the top wall are side walls 17, a front wall 18 and a rear wall 19. Said side, front and rear walls are curved transversely and have lower edges.

Attached to the underside of the rear end of the base, as by rivet 20, is a pad 21 of rubber-like material having portions 22 contacting the under edges of the rear wall 19 and adjacent portions of the side walls 17.

Adjacent its front end, said top wall 16 has a depression 24 for a usual staple anvil 25.

Adjacent its rear end, wall 16 is formed with a longitudinal, rectangular depressed wall 26. Said wall 26 is formed adjacent its front end, with a transverse slot 27. Rearwardly of said slot 27, wall 26 is formed with a round hole 28 located on the longitudinal axis of the base. Rearwardly of hole 28, said depressed wall 26 is formed with a longitudinal slot 29 in line with hole 28, and terminating short of the rear end of said depressed wall.

Fixed to the top of depressed wall 26 is a base bracket 30 having a bottom wall 31 contacting and nested on the upper surface of said depressed wall and welded or otherwise attached thereto. Extending up from the bottom wall 31, are parallel, vertical side walls 32 having upwardly and forwardly curved top edges 33, and front edges 34. The bottom wall 31 is formed with a transverse slot 35 registering with slot 27 and with a round hole 38 registering with hole 28. It is also formed with a short slot 39 registering with the front end of slot 29 and terminating rearwardly of the front end of slot 29.

Contacting walls 26, 31 are formed adjacent their rear ends with registering openings 26a, 31a receiving a rivet 40 which attaches the horizontal rearwardly extending foot 41 of an angle shaped stop member 42 to the top of said wall 31. Extending up from the forward end of foot 41 is a flange 43 having an upper edge 44 disposed below the upper edge 33 of side walls 32 of the base bracket.

Side walls 32 are formed adjacent their rear ends, with outwardly pressed walls 45 forming inner downwardly extending grooves 46, each having an upper flaring mouth 46a and a half round narrower lower end 46b.

Extending loosely through registering openings 28, 38 is a pin 50 having a head 51 at its upper end, and a head 52 at its lower end. Interposed between wall 31 of base bracket 30 and head 51 and surrounding pin 50, is a coil compression spring 53 of increasing diameter toward its lower end.

On lower head 52 is a washer 54. Assembled with the

base 11, is an operating member 55 having an intermediate portion 56 formed with a hole 57 through which pin 50 passes, and resting on washer 54, and located beneath the depressed wall 26. At the forward end of said intermediate portion 56 is an upstanding finger or flange 58 passing upwardly through registering transverse slots 27, 35. The upper edge 58a of flange 58 is substantially at the level of edge 44 of flange 43. Said intermediate portion 56 contacts the underside of wall 26 adjacent to its slot 27.

At the rear end of said intermediate portion 56, is a downwardly extending web 60 from the lower end of which extends rearwardly a tongue 61 disposed below wall 26 in spaced relation thereto.

Also assembled with the base is a pawl 64 comprising a portion 65 disposed in a vertical plane and a push button portion 66 at one end of the vertical portion in a plane at right angles thereto. Said portion 65 has a front finger 67 passing upwardly through slots 29, 39, an intermediate portion 68 disposed in slot 29 and below wall 31 of bracket 30, and lying over tongue 61, and a rear portion 69 projecting downwardly and rearwardly, and disposed in back of the rear end of said tongue.

The operative position of pawl 64, hookingly engaging a transverse pivot pin 70 on the staple magazine 12, is illustrated in FIGS. 1 and 4. This is the normal position of the pawl. Portion 65 of pawl 64, has a forwardly extending lug 71 at the lower, front end of finger 67, located in the forward end of slot 29 and engaging the underside of wall 31 just forwardly of slot 39, in the engaging or normal position of the pawl, as shown in FIG. 4. The rear lower end of finger 67 contacts the rear of slot 39.

Portion 68 has an upper straight edge 72 extending rearwardly of finger 67 and contacting the underside of wall 31, in said engaging position of the pawl. Extending from the rear end of edge 72 is an upper straight edge 73 disposed at an angle of about 15° to the underside of wall 31, in said engaging or normal condition of the pawl.

At the middle of the underside of portion 68 is a downwardly projecting lug 74 contacting the upper side of tongue 61 adjacent the rear end of the latter. Button 66 is located below and rearwardly of tongue 61. Button 66 may be square in shape, if desired.

It will now be understood that spring 53 presses pin upwardly so that tongue 61 presses up on lug 74 to rotate pawl 64 about the fulcrum point 75 at the junction of edges 72, 73, to keep edge 72 and lug 71 in contact with wall 31.

It will be noted that fulcrum 75 is disposed rearwardly of lug 74 as shown in the drawing.

At the upper end of finger 67 is a rearwardly extending hook 76 having a curved hooked under edge 77 and an upper downwardly and rearwardly slanting edge 78.

The staple magazine 12 and cover 13 may be of usual construction, being interpivotated by a transverse pivot pin 80.

The hook 76 holds the pin 70 seated in portions 46b of grooves 46 when the magazine is assembled.

The staple magazine 12 has side walls 81, and a bottom wall 82. Forwardly of the rear end of the magazine, its side walls 81 have downwardly extending ears 83 carrying the transverse pin 70. Said pin 70 has ends 70a adapted to project into grooves 46.

To connect the interpivotated staple magazine and cover to the base, the pin 70 is manipulated so that its ends 70a move down through the flaring portions 46a of grooves 46. As the center of the pin 70 contacts edge 78, pawl 64 is rocked in a clockwise direction, looking at FIGS. 4 and 5, about its fulcrum 75, thereby causing lug 74 to depress tongue 61 and tension further, the spring 53. When the pin 70 passes the hook 76, spring 53, causing upward pressure of the tongue 61 against lug 74, will cause counterclockwise rotation of the pawl about

fulcrum 75, to the position of FIG. 4, in which position the pin is locked and the magazine cover cannot be removed.

The bottom wall of the staple magazine contacts the upper edges of flanges 43, 58, and hence spring 53 normally keeps the magazine parallel to and spaced above the base. However when the stapler is operated, the magazine will pivot about the axis of its pin 70, causing depression of flange 58 and increased pressure on spring 53 to again lift the magazine when hand pressure is removed from the stapler.

To release the magazine-cover, it is merely necessary to press up on button 66, causing the pawl 64 to rock in a clockwise direction about fulcrum 75, depressing tongue 61 and disengaging hook 76 from the pin 70 to permit lifting out the magazine-cover.

It will thus be seen that there is provided an apparatus in which the several objects of this invention are achieved and which is well adapted to meet the conditions of practical use.

As possible embodiments might be made of the above invention, and as various changes might be made in the embodiment above set forth, it is to be understood that all matter herein set forth or shown in the accompanying drawings is to be interpreted as illustrative and not in a limiting sense.

I claim:

1. In a stapling device, a base having a wall, a base bracket having a bottom wall fixed to said wall of the base, said bracket having upwardly extending side walls formed with guide grooves and with bearing means at the ends of said grooves, said wall of said base being formed with a hole and with a longitudinal slot, said bottom wall of the bracket being formed with a hole registering with the hole in said wall of the base, and with a longitudinal slot registering with part of the longitudinal slot in said wall of said base, a pin passing through said registering holes and having heads at its upper and lower ends, a member having a portion formed with a hole registering with said aforementioned holes and through which the pin passes, said portion being interposed between the lower head of the pin and the underside of said wall of the base, a coil compressed spring interposed between the bottom wall of the bracket and the upper head of said pin, said member having a rearwardly extending tongue, a pawl having an intermediate portion interposed between said tongue and the underside of said bottom wall of the bracket and extending in the longitudinal slot in said base wall, said pawl having a finger extending up through the registering longitudinal slots and provided with a hook at its upper end, said portion of said pawl having a fulcrum contacting the underside of said bottom wall, and a lug disposed forwardly of the fulcrum contacting said tongue, in combination with a staple magazine having a fixed pin, said fixed pin having ends engaging said bearing means and said hook engaging said pin to hold its ends on said bearing means, said walls of said base and bracket having registering transverse slots, and said member having a flange at its forward end projecting up through said registering transverse slots and engaging said magazine.

2. The combination of claim 1, in combination with a stop fixed to said bottom wall rearwardly of said guide grooves and engaging said magazine.

3. In a stapler, a base, a staple magazine, a pin on said staple magazine, said base having guide means for said pin, and bearing means for the pin at the end of the guide means, a pawl rockingly mounted on said base and having bearing means to releasably engage said pin and hold said pin on said first mentioned bearing means, spring means to move said pawl into pin engaging position, thereby removably connecting said magazine to said base for rotation about the axis of said pin, said pawl having means in the path of the pin moving through the guide means toward said first bearing means, to move

5

said pin engaging means out of the guide means to permit said pin to engage said first bearing means, said spring means including means to resiliently bias said magazine upwardly relative to the base, forwardly of said pin.

4. The combination of claim 3, in combination with 5 fixed stop means on the base engaging the underside of said magazine, rearwardly of said pivot pin.

6

References Cited in the file of this patent

UNITED STATES PATENTS

2,512,172	Oiney -----	June 20, 1950
2,719,971	Boroughs -----	Oct. 11, 1955

FOREIGN PATENTS

1,004,065	France -----	Nov. 21, 1951
-----------	--------------	---------------