



1a 1b

2a 2b

2c -

\*

\*

20 : 21 ;

21a : 21b :

22 : 23 :

24 : 25 :

25a : 25b :

26 : 27 :

,

,

,

,

,

가

1a , (10) (11) (15) ,  
(15) (11) ( )

(11b) , (11) (15) (11) 가  
(11)

a) , (15) (15a) (15b) .  
(17) (17) (11) (15)  
CT (15b) (17) (17) (15b)

1b 1a A - A'

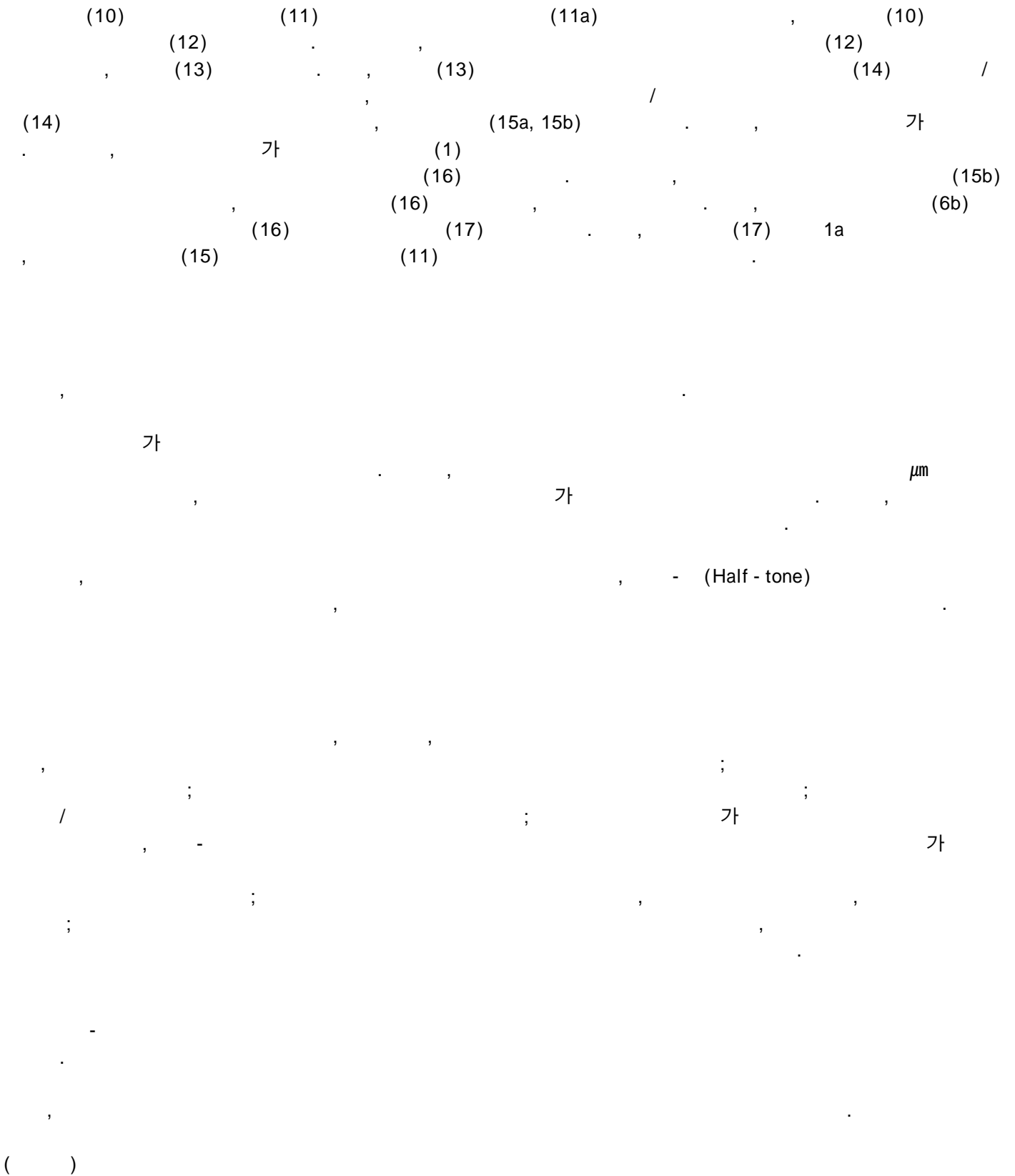

2a , 2b 2a A - A'

2a (20) (21) (25) ,  
 (25) (21) ( )

(21b) (21) (25) 가  
 (21)

a) (25) (25a) (25b) .  
 (27) (27) (21) (25)  
 CT (25b) (27) (27) (25b)

2b (20) (21a) (11a) ,  
 (22) (20) (22) ,  
 (23) (24)  
 / /  
 가 가 (25a, 25b)  
 (20)  
 (26)

(26) - (Half - tone)  
 (25b) (11a) (26) 가  
 (21a)  
 (26)  
 (25b)  
 (26) (25b) (26)  
 (27) (27) 2a (25)  
 (21)

2c - (Half - tone) (100)  
 (101) (102) (110)  
 100% (103: ) (102)  
 (104) 30 70% (105: )  
 (110) (26) (105)  
 (26) 2b

$\mu\text{m}$  1/3 가

가  $\mu\text{m}$  1/3 가 .

(57)

1.

;

;

;

/ ;

가 가 , - ;

;

;

2.

1 , -

3.

1 ,

1a

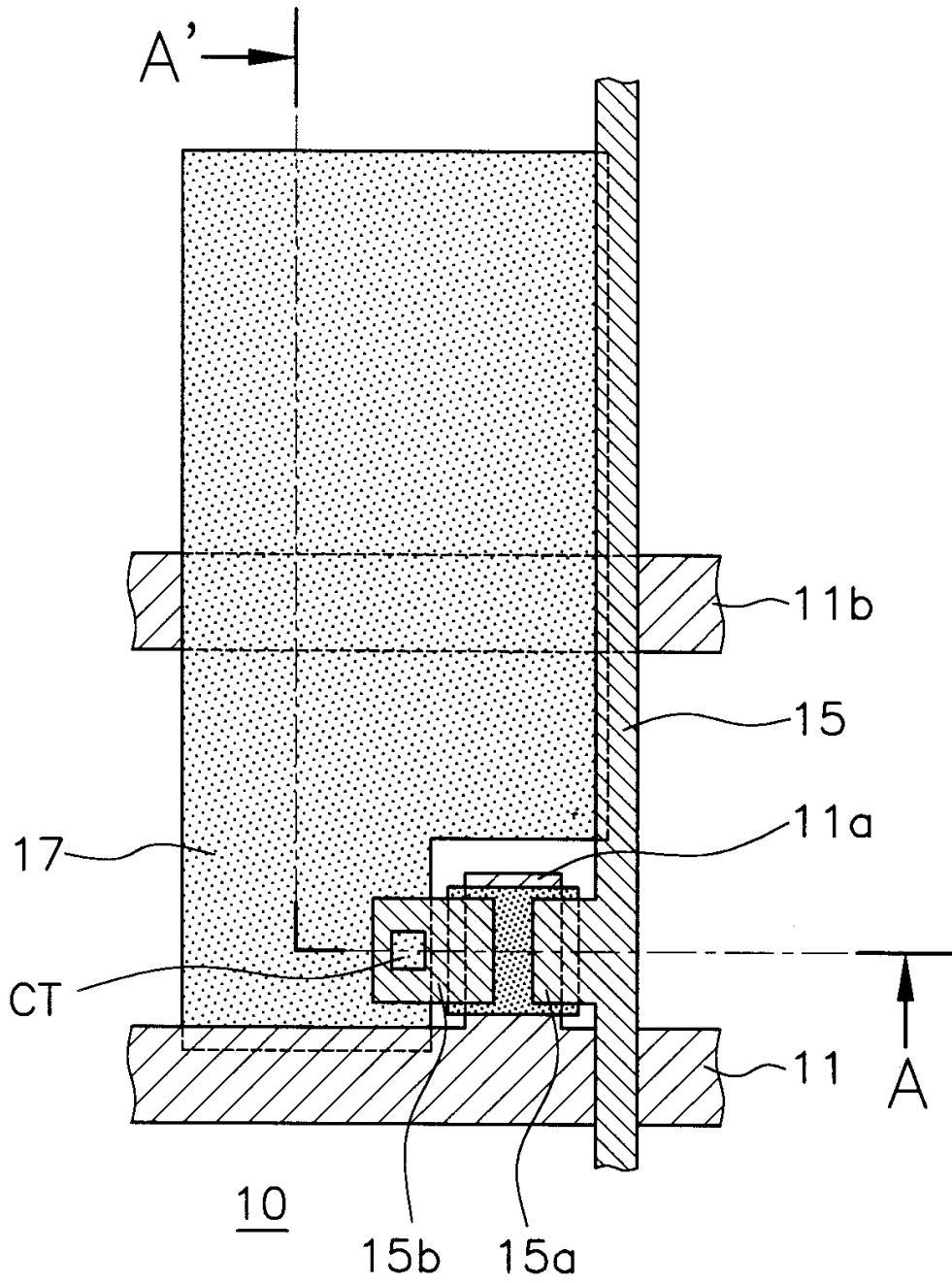

1b

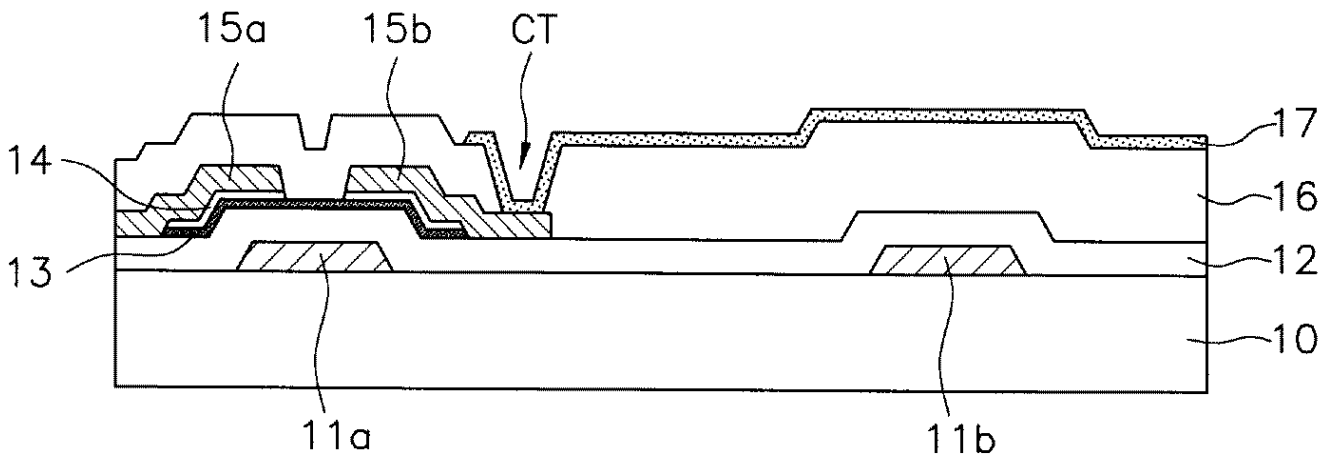

2a

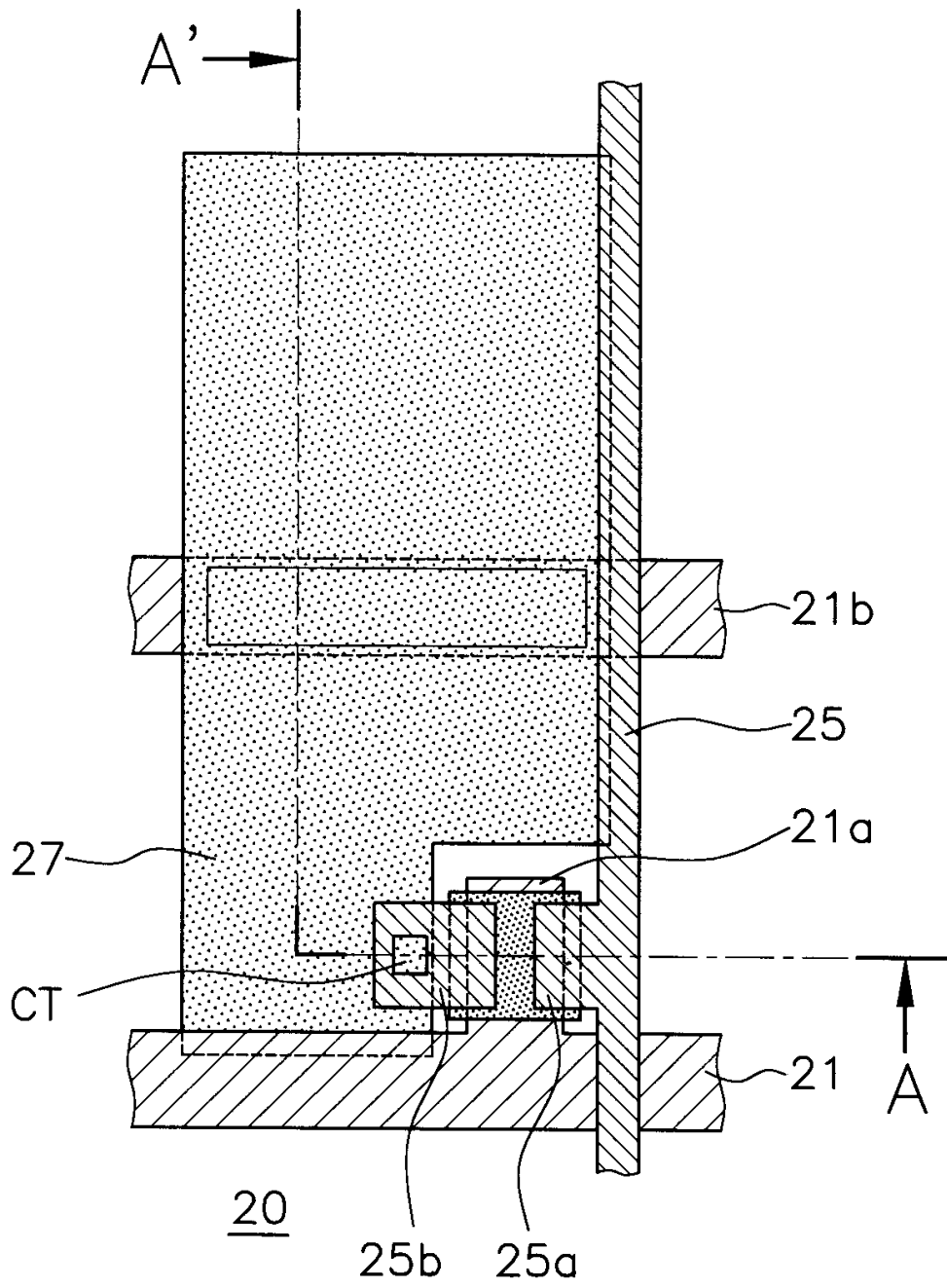

2b

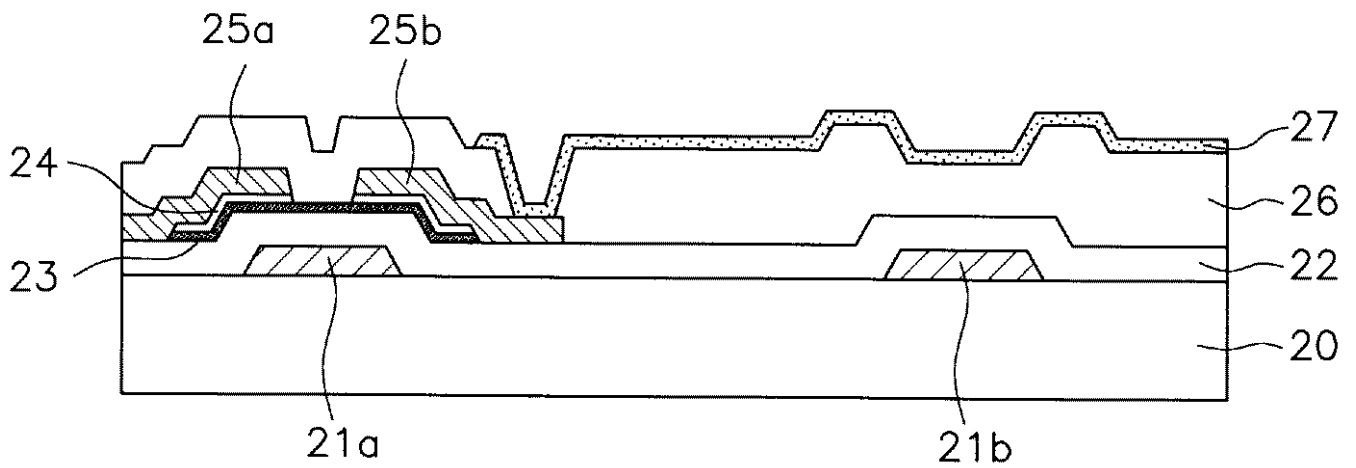

2c

