



US010772466B2

(12) **United States Patent**
O'Shaughnessy et al.

(10) **Patent No.:** **US 10,772,466 B2**
(45) **Date of Patent:** **Sep. 15, 2020**

(54) **GRILL ASSEMBLY WITH FOLDABLE CART**

(56) **References Cited**

(71) Applicant: **OHC IP Holdings, LLC**, Eden Prairie, MN (US)

U.S. PATENT DOCUMENTS

(72) Inventors: **Michael L. O'Shaughnessy**, Edina, MN (US); **James A. Mitlyng**, Minneapolis, MN (US); **Thomas E. Mckinney**, Minnetonka, MN (US)

3,802,413 A 4/1974 Pepin
4,211,206 A 7/1980 Darbo
4,569,327 A 2/1986 Velten
(Continued)

FOREIGN PATENT DOCUMENTS

(73) Assignee: **OHC IP Holdings, LLC**, Eden Prairie, MN (US)

CN 201005546 1/2008
CN 202801180 3/2013
(Continued)

(*) Notice: Subject to any disclaimer, the term of this patent is extended or adjusted under 35 U.S.C. 154(b) by 0 days.

OTHER PUBLICATIONS

(21) Appl. No.: **16/450,541**

"Brown Jordan Outdoor Kitchens," by Danver Stainless Outdoor Kitchens information booklet, Apr. 2018 (28 pages).

(22) Filed: **Jun. 24, 2019**

(Continued)

(65) **Prior Publication Data**

US 2020/0000281 A1 Jan. 2, 2020

Primary Examiner — Vivek K Shirsat

Assistant Examiner — Ko-Wei Lin

(74) *Attorney, Agent, or Firm* — Pauly, DeVries Smith & Deffner LLC

Related U.S. Application Data

(60) Provisional application No. 62/690,700, filed on Jun. 27, 2018.

(51) **Int. Cl.**
A47J 37/07 (2006.01)

(52) **U.S. Cl.**
CPC *A47J 37/0713* (2013.01); *A47J 37/0786* (2013.01); *A47J 2037/0777* (2013.01)

(58) **Field of Classification Search**
CPC *A47J 37/07*; *A47J 2037/0777*; *A47J 37/0763*; *A47J 37/0704*
USPC 126/25 R, 9 R, 9 B, 41 R, 30, 50, 276; 280/651

See application file for complete search history.

(57) **ABSTRACT**

In an embodiment, a grill is provided. The grill can include a grill cart and a burner box. The grill cart configured to be transitioned between an upright state and a folded state. The coupling between a first side frame and a base is located in a first plane that is substantially parallel with a plane defined by a bottom plate of the base, and the coupling between a second side frame and the bottom plate of the base is located in a second plane that is substantially parallel with the plane defined by the bottom plate. The first plane is located a first distance away from the plane defined by the bottom plate and the second plane is located a second distance away from the plane defined by the bottom plate. The first distance is not equivalent to the second distance. Other embodiments are also included herein.

11 Claims, 23 Drawing Sheets

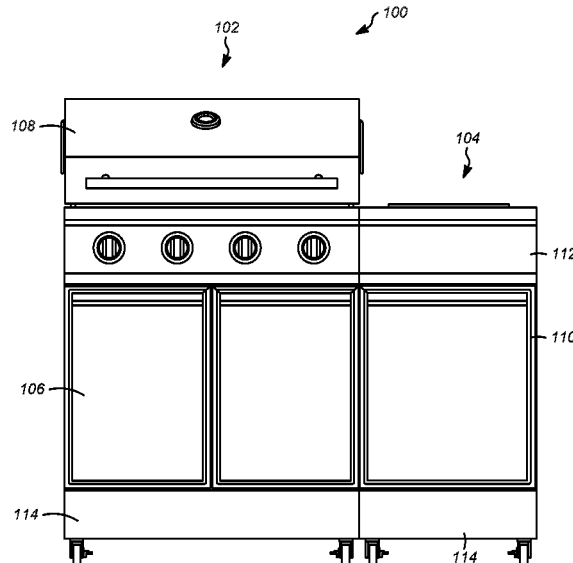

(56)

References Cited

FOREIGN PATENT DOCUMENTS

| U.S. PATENT DOCUMENTS | | | |
|-----------------------|-----|---------|---------------------------------------|
| 4,577,772 | A | 3/1986 | Bigliardi |
| 4,887,836 | A | 12/1989 | Simjian |
| 4,949,701 | A | 8/1990 | Krosp et al. |
| 4,984,515 | A | 1/1991 | Pivonka |
| 5,040,809 | A | 8/1991 | Yang |
| 5,050,731 | A | 9/1991 | Baynes et al. |
| 5,065,734 | A | 11/1991 | Elliott |
| 5,261,550 | A | 11/1993 | Karpisek |
| 5,462,318 | A | 10/1995 | Cooke |
| 5,884,554 | A | 3/1999 | Sprick |
| 6,039,039 | A | 3/2000 | Pina, Jr. |
| 6,316,837 | B1 | 11/2001 | Song |
| 6,401,953 | B2 | 6/2002 | Kofod |
| 6,439,111 | B1 | 8/2002 | Lu |
| 6,439,220 | B1 | 8/2002 | Johnson |
| 6,439,221 | B1 | 8/2002 | Ward et al. |
| 6,494,419 | B2 | 12/2002 | Pai |
| 6,532,951 | B1 | 3/2003 | Sallie et al. |
| 6,606,986 | B2 | 8/2003 | Holland et al. |
| 6,619,600 | B1 | 9/2003 | Johnson et al. |
| 6,823,858 | B1 | 11/2004 | Chen |
| 6,916,028 | B2 | 7/2005 | Shapiro |
| 7,360,783 | B2 | 4/2008 | Home |
| 7,753,047 | B1 | 7/2010 | Trammell |
| 7,856,924 | B1 | 12/2010 | Stihi |
| 8,042,829 | B2 | 10/2011 | Hailston et al. |
| 8,316,837 | B2 | 11/2012 | Malumyan |
| 8,602,017 | B2 | 12/2013 | May et al. |
| 9,187,108 | B2 | 11/2015 | Bruno et al. |
| 9,211,036 | B2 | 12/2015 | May et al. |
| 9,392,904 | B2 | 7/2016 | Garman |
| 9,817,108 | B2 | 11/2017 | Kuo et al. |
| 10,689,018 | B2 | 6/2020 | Patton et al. |
| 10,702,099 | B2 | 7/2020 | O'Shaughnessy et al. |
| 2001/0015137 | A1 | 8/2001 | O'Grady et al. |
| 2004/0020482 | A1 | 2/2004 | Chen |
| 2004/0065313 | A1 | 4/2004 | Thompson |
| 2006/0049725 | A1 | 3/2006 | Simon |
| 2006/0225725 | A1 | 10/2006 | Rinaldo |
| 2007/0089724 | A1* | 4/2007 | Home A47J 37/0704 126/9 R |
| 2007/0152414 | A1* | 7/2007 | Home A47J 37/0704 280/47.35 |
| 2008/0245357 | A1 | 10/2008 | Meether et al. |
| 2010/0031950 | A1 | 2/2010 | Paslowski |
| 2010/0326938 | A1 | 12/2010 | Zhu et al. |
| 2011/0025005 | A1 | 2/2011 | Howell |
| 2011/0041831 | A1 | 2/2011 | Dettloff |
| 2011/0168155 | A1 | 7/2011 | Gallo |
| 2011/0168168 | A1 | 7/2011 | Schneider |
| 2011/0168593 | A1* | 7/2011 | Neufeld B65D 19/0012 206/386 |
| 2012/0017890 | A1 | 1/2012 | May et al. |
| 2013/0049311 | A1 | 2/2013 | Metters et al. |
| 2013/0112088 | A1 | 5/2013 | May |
| 2014/0069412 | A1 | 3/2014 | Garman |
| 2014/0165992 | A1 | 6/2014 | May et al. |
| 2014/0261394 | A1 | 9/2014 | Evans et al. |
| 2015/0013667 | A1 | 1/2015 | Ho et al. |
| 2015/0020796 | A1 | 1/2015 | Garman et al. |
| 2015/0118006 | A1 | 4/2015 | Wallace-riley |
| 2016/0305172 | A1 | 10/2016 | Grisendi |
| 2017/0085114 | A1 | 3/2017 | Gao et al. |
| 2017/0095114 | A1 | 4/2017 | O'shaughnessy et al. |
| 2017/0159941 | A1 | 6/2017 | Kahler et al. |
| 2018/0141576 | A1 | 5/2018 | Leffler et al. |
| 2018/0280677 | A1 | 10/2018 | Knight |
| 2018/0290677 | A1 | 10/2018 | Patton et al. |
| 2020/0000277 | A1 | 1/2020 | O'Shaughnessy et al. |
| 2020/0000278 | A1 | 1/2020 | O'Shaughnessy et al. |
| 2020/0000279 | A1 | 1/2020 | O'Shaughnessy et al. |
| 2020/0000280 | A1 | 1/2020 | O'Shaughnessy et al. |
| 2020/0000283 | A1 | 1/2020 | O'Shaughnessy et al. |

| | | |
|----|-------------|---------|
| CN | 205632566 | 10/2016 |
| CN | 107198467 | 9/2017 |
| JP | 2006223643 | 8/2006 |
| KR | 200173343 | 4/2000 |
| KR | 20050102437 | 10/2005 |
| KR | 20130000879 | 2/2013 |
| TW | 309958 | 7/1997 |
| WO | 2004054415 | 7/2004 |
| WO | 2004072539 | 8/2004 |
| WO | 2015089551 | 6/2015 |
| WO | 2016149408 | 11/2016 |
| WO | 2017095746 | 6/2017 |
| WO | 2017160338 | 9/2017 |
| WO | 2018183373 | 10/2018 |
| WO | 2020005946 | 1/2020 |
| WO | 2020005969 | 1/2020 |
| WO | 2020005972 | 1/2020 |
| WO | 2020005976 | 1/2020 |
| WO | 2020005978 | 1/2020 |
| WO | 2020005981 | 1/2020 |

OTHER PUBLICATIONS

Colon, Linda M. "Danver's Post and Panel System is a Hit with Architects, Builders, Developers & Designers," Danver Outdoor Kitchens Jun. 1, 2018 (2 pages).

File History for U.S. Appl. No. 15/262,733 downloaded Aug. 23, 2019 (326 pages).

File History for U.S. Appl. No. 15/937,666 downloaded Aug. 23, 2019 (201 pages).

"First Office Action," for Chinese Patent Application No. 20110876503.3 dated Dec. 18, 2018 (14 pages) with English Translation.

"International Preliminary Report on Patentability," for PCT Application No. PCT/US2016/051319 dated Sep. 27, 2018 (11 pages).

"International Search Report and Written Opinion," for PCT Application No. PCT/US2016/051319 dated Dec. 8, 2016 (14 pages).

"International Search Report and Written Opinion," for PCT Application No. PCT/US2018/024628 dated Jul. 11, 2018 (16 pages).

"Modular Outdoor Kitchen," Char-Broil Medallion Series Outdoor Kitchen information retrieved from <https://www.charbroil.com/grills/modular-outdoor-kitchen> on Aug. 8, 2019 (4 pages).

"Origami Kitchen Island Cart with Wheels," Description and Product Specs at least as early as Aug. 9, 2019 (5 pages).

"Traeger Wood Pellet Grills," Product Listing found on www.traegergrills.com at least as early as Aug. 9, 2019 (4 pages).

"Char-Broil Modular Outdoor Kitchen," Char Broil webpage Apr. 29, 2019, retrieved on Aug. 8, 2019, <https://www.charbroil.com/grills/outdoor-kitchens/modular-outdoor-kitchen> (4 pages).

"Danver's Post and Panel System," Danver webpage Jun. 1, 2018, retrieved on Aug. 8, 2019, <https://danver.com/blog/post-and-panel-system/> (2 pages).

"Final Office Action," for U.S. Appl. No. 15/262,733 dated Sep. 5, 2019 (14 pages).

"International Preliminary Report on Patentability," for PCT Application No. PCT/US2018/024628 dated Oct. 10, 2019 (13 pages).

"International Search Report and Written Opinion," for PCT Application No. PCT/US2019/038993 dated Oct. 15, 2019 (13 pages).

"International Search Report and Written Opinion," for PCT Application No. PCT/US2019/039024 dated Oct. 15, 2019 (14 pages).

"International Search Report and Written Opinion," for PCT Application No. PCT/US2019/039027 dated Oct. 15, 2019 (13 pages).

"International Search Report and Written Opinion," for PCT Application No. PCT/US2019/039034 dated Oct. 15, 2019 (12 pages).

"International Search Report and Written Opinion," for PCT Application No. PCT/US2019/039039 dated Oct. 16, 2019 (14 pages).

"International Search Report and Written Opinion," for PCT Application No. PCT/US2019/039042 dated Oct. 16, 2019 (13 pages).

"Non-Final Office Action," for U.S. Appl. No. 16/450,303 dated Oct. 24, 2019 (19 pages).

"Origami Carts and Racks," Origami webpage Apr. 20, 2016, retrieved on Dec. 9, 2019 via web.archive.org, <https://origamirack.com> (12 pages).

(56)

References Cited

OTHER PUBLICATIONS

“Response to Final Office Action,” for U.S. Appl. No. 15/262,733, filed on Dec. 5, 2019 (11 pages).

“Second Office Action,” for Chinese Patent Application No. 201610876505.3 dated Aug. 29, 2019 (4 pages) with English Translation.

“Sunco Outdoor Kitchen,” Mar. 16, 2018 RL <<https://www.sunco.com.au/shop/bbqs/sc100-xspec-four-burner-outdoor-kitchen/>> (3 pages).

“Traeger Wood Pellet Grills,” Traeger Grills webpage Apr. 7, 2006, retrieved on Dec. 9, 2019 via web.archive.org, <https://www.traegergrills.com> (2 pages).

“Non-Final Office Action,” for U.S. Appl. No. 15/262,733 dated Jan. 8, 2020 (18 pages).

“Third Office Action,” for Chinese Patent Application No. 201610876505.3 dated Mar. 19, 2020 (8 pages) with English Translation.

* cited by examiner

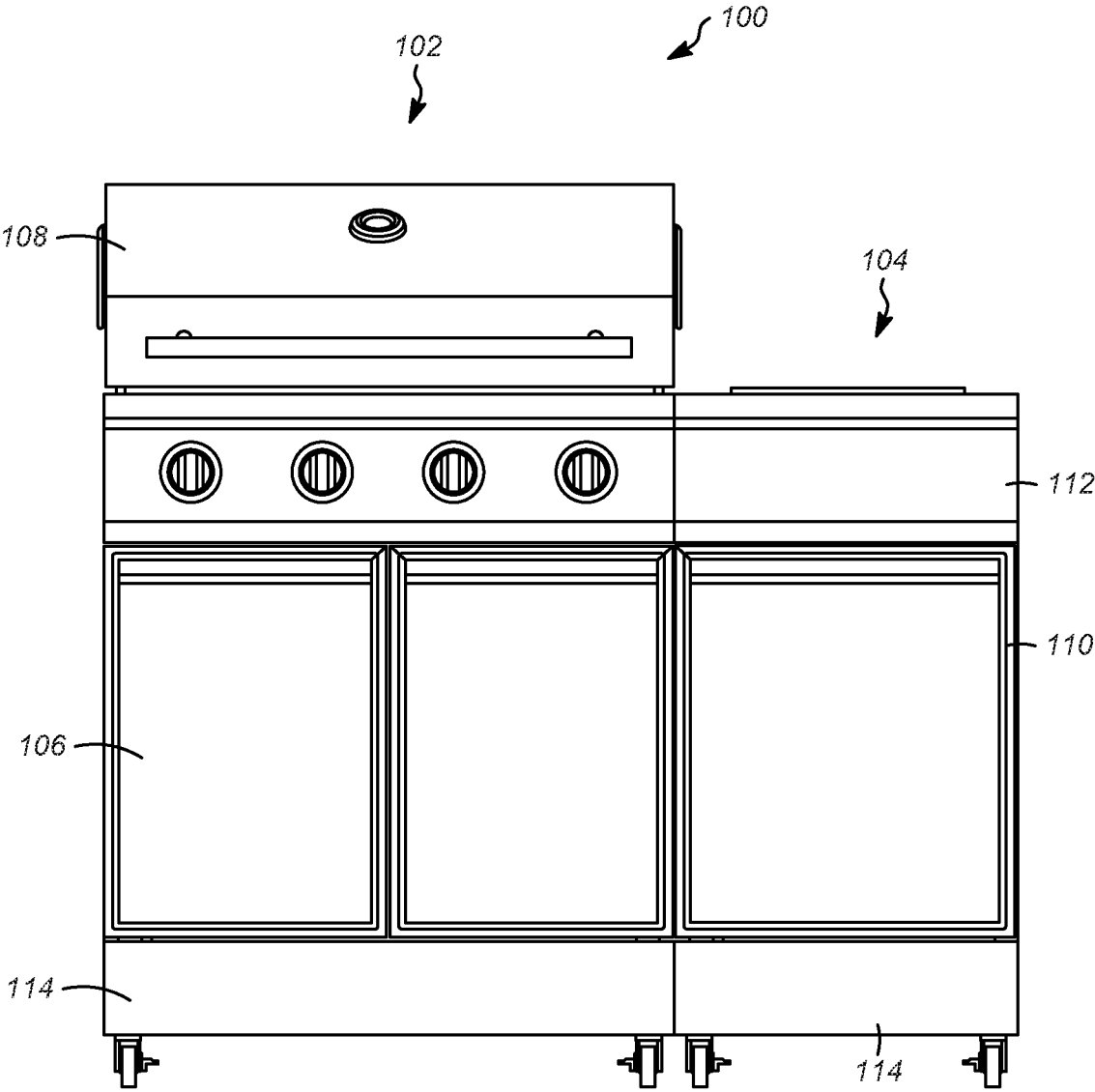

FIG. 1

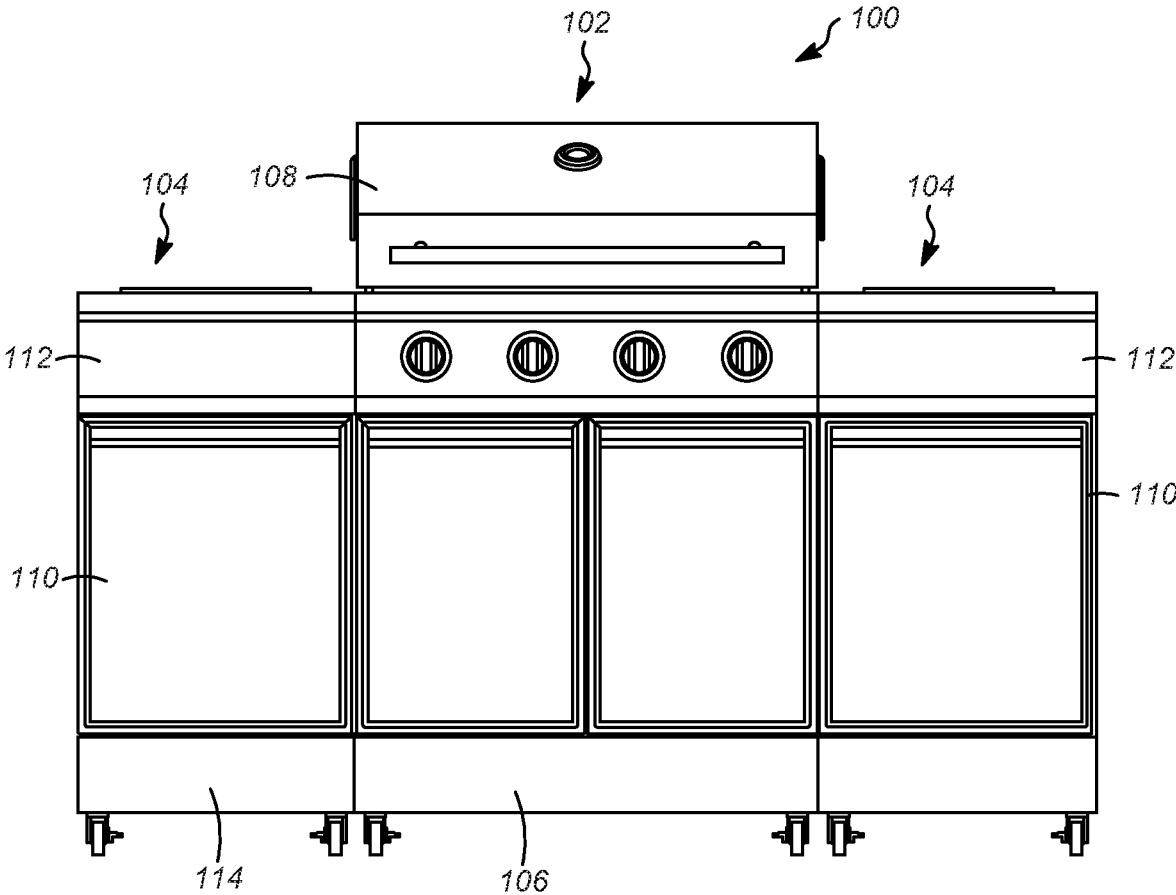

FIG. 2

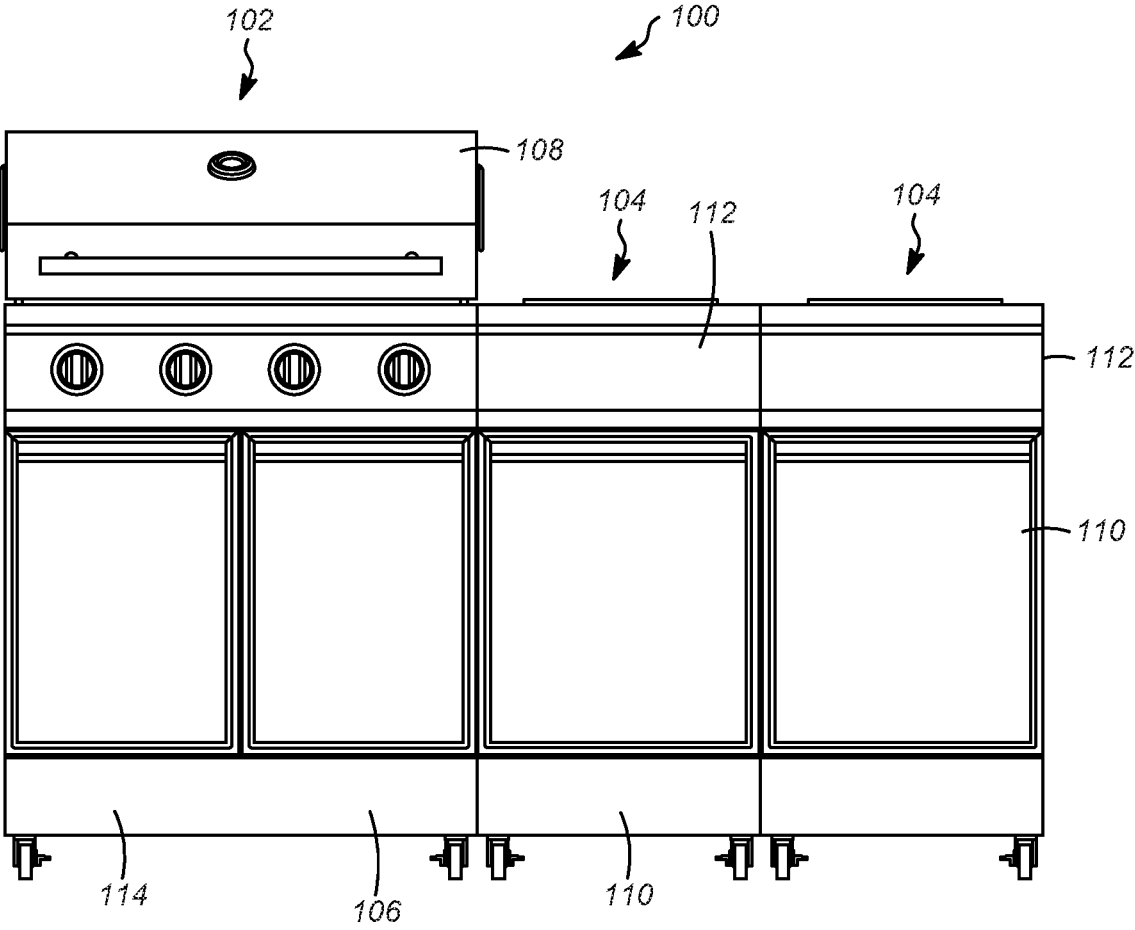

FIG. 3

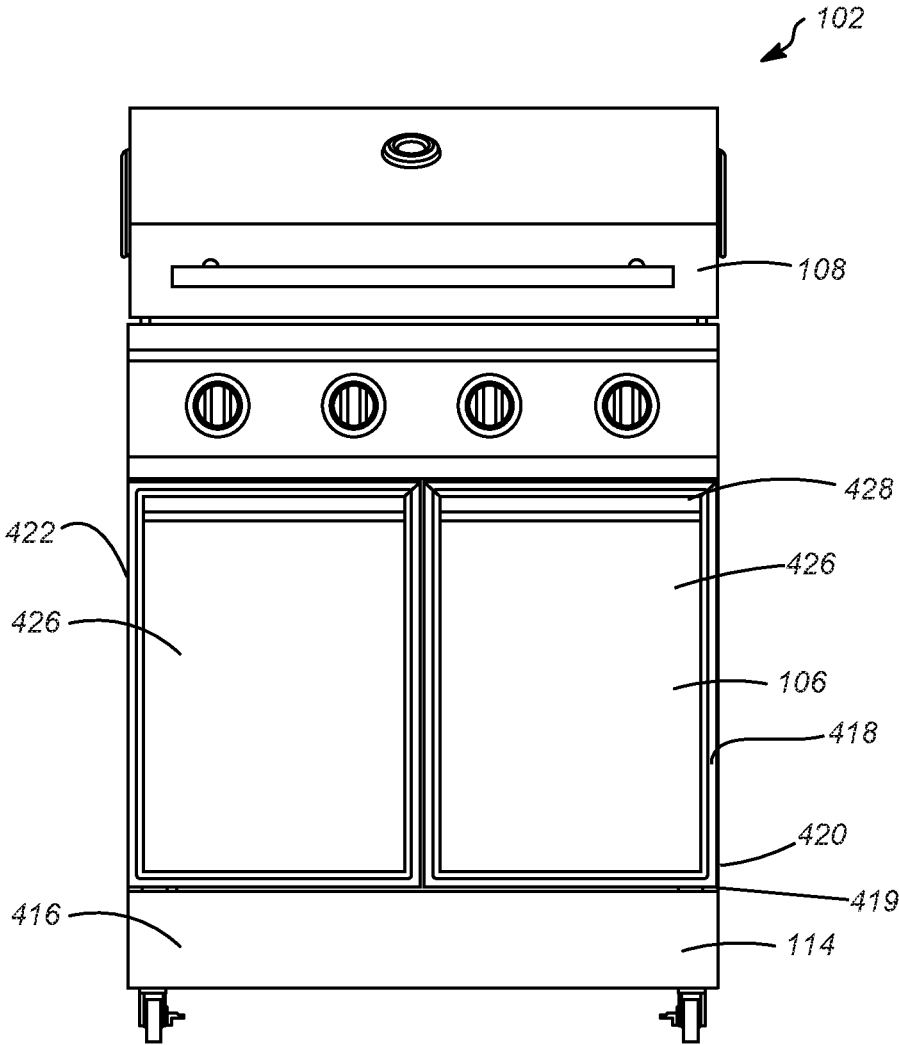

FIG. 4

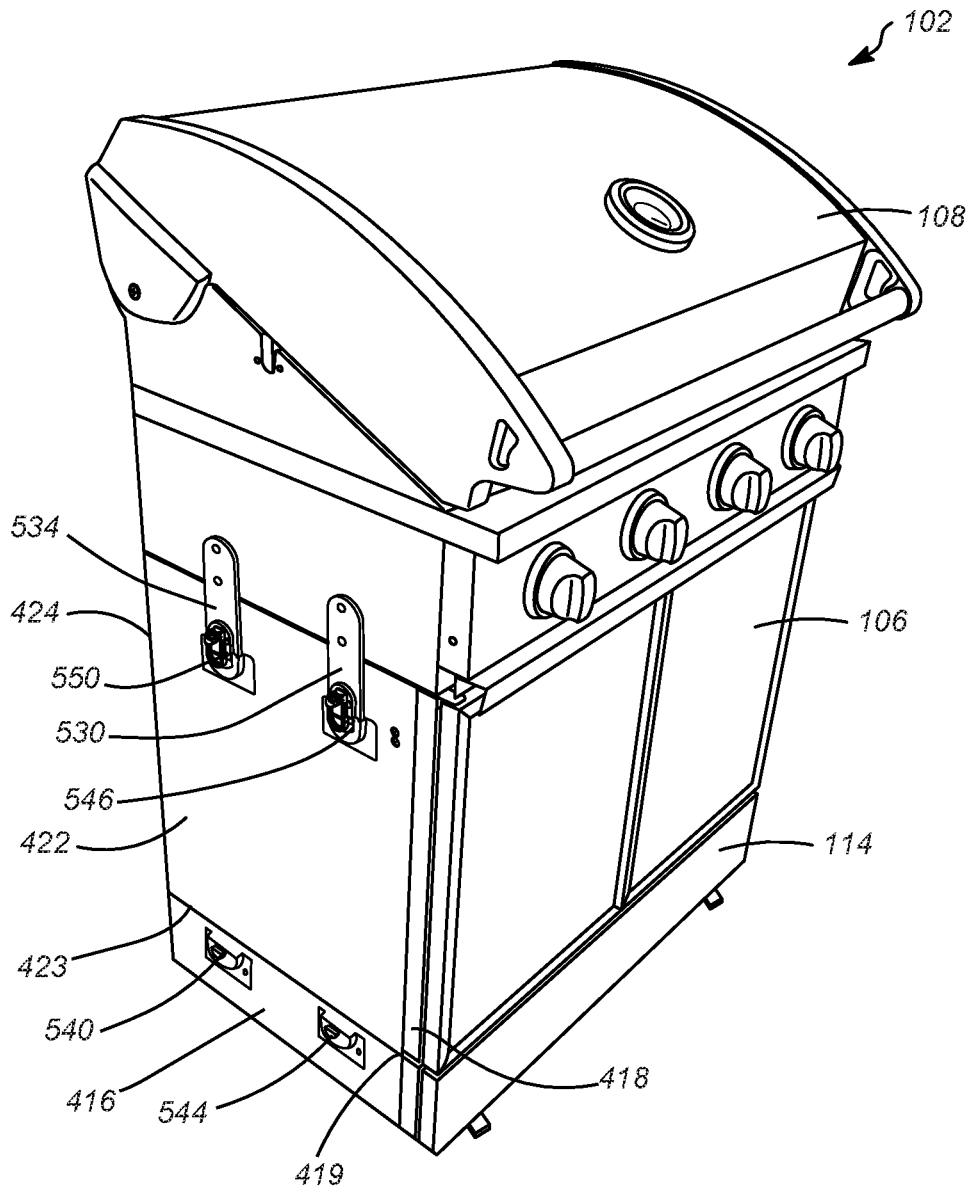

FIG. 5

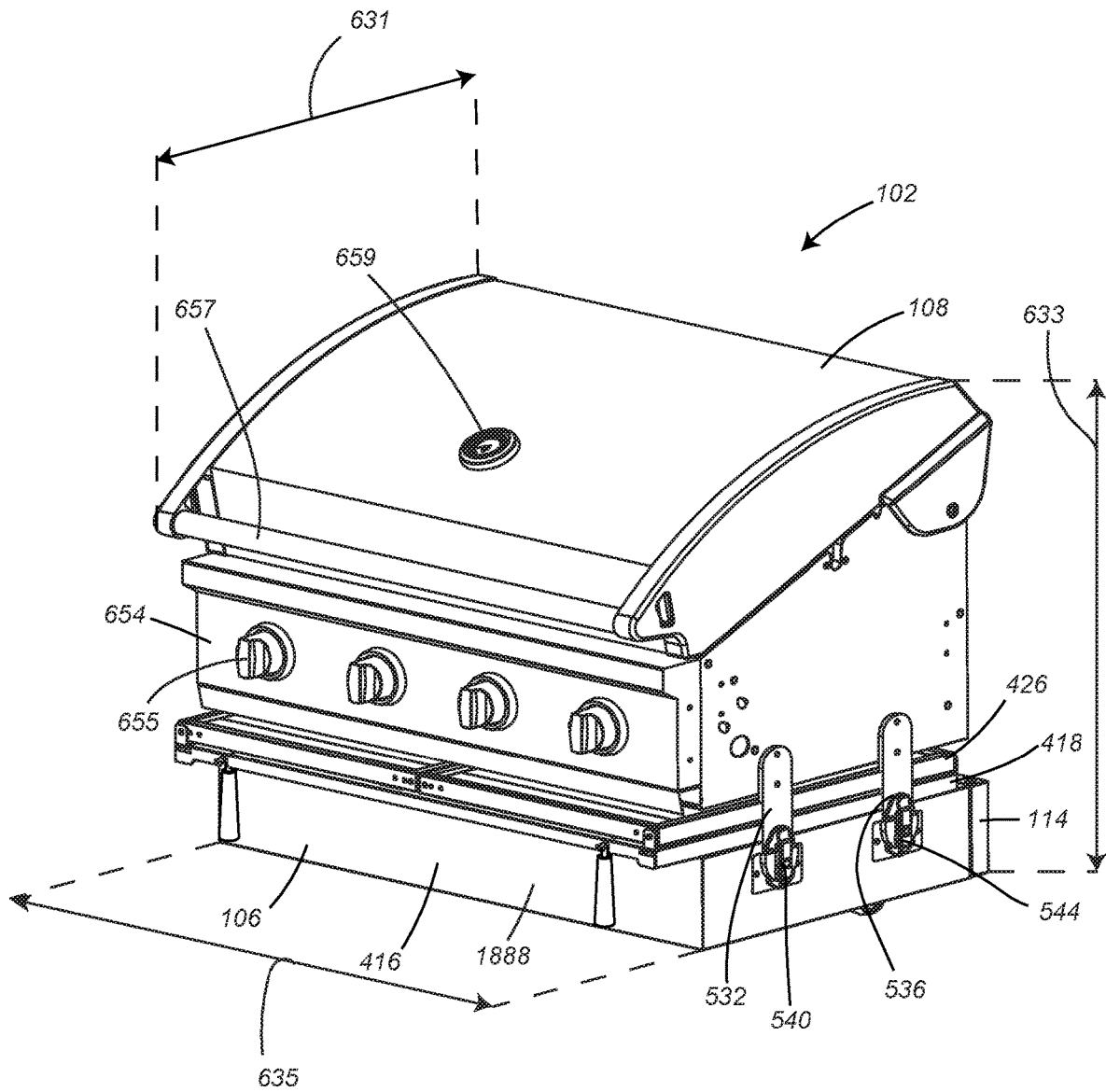

FIG. 6

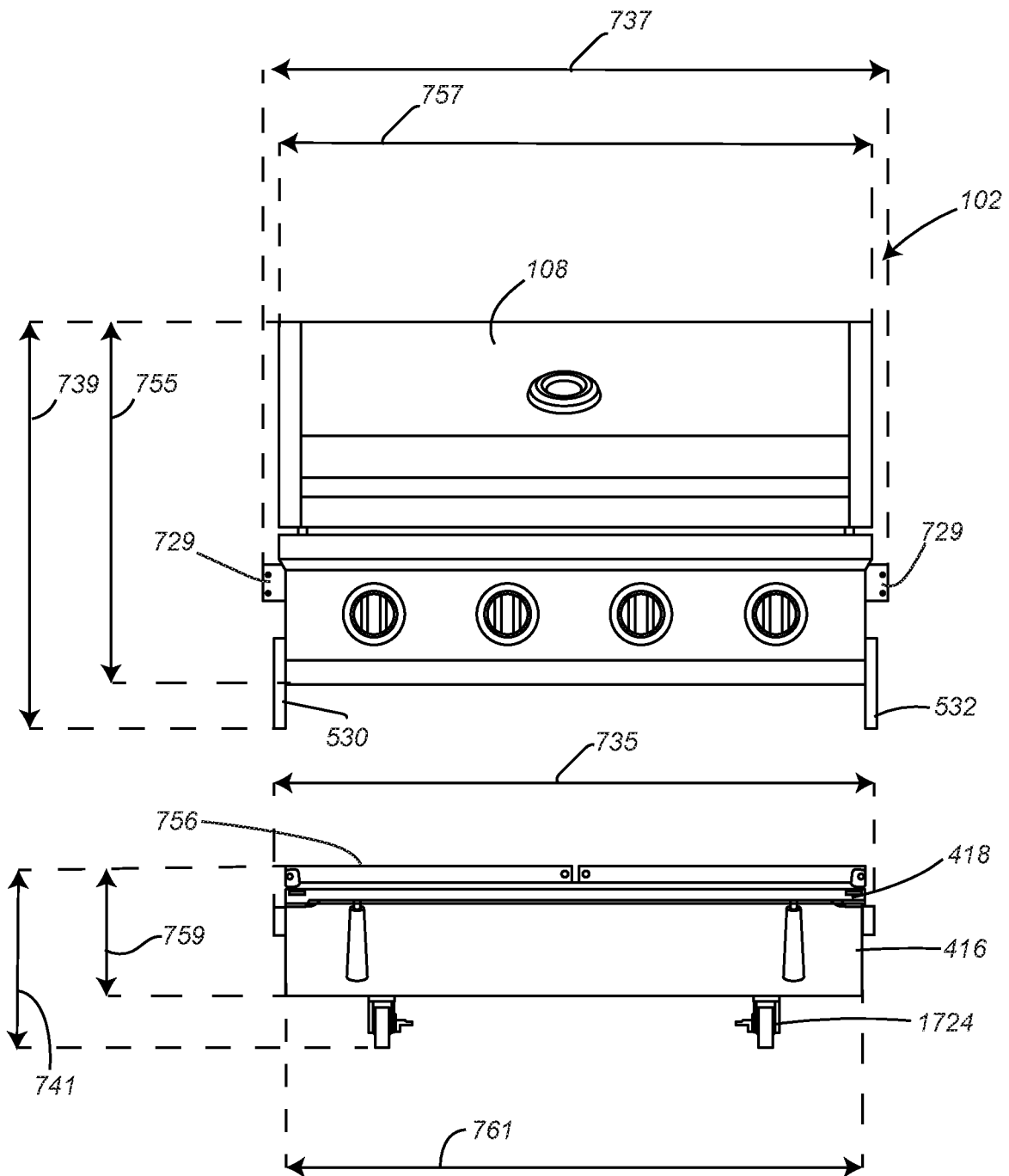

FIG. 7

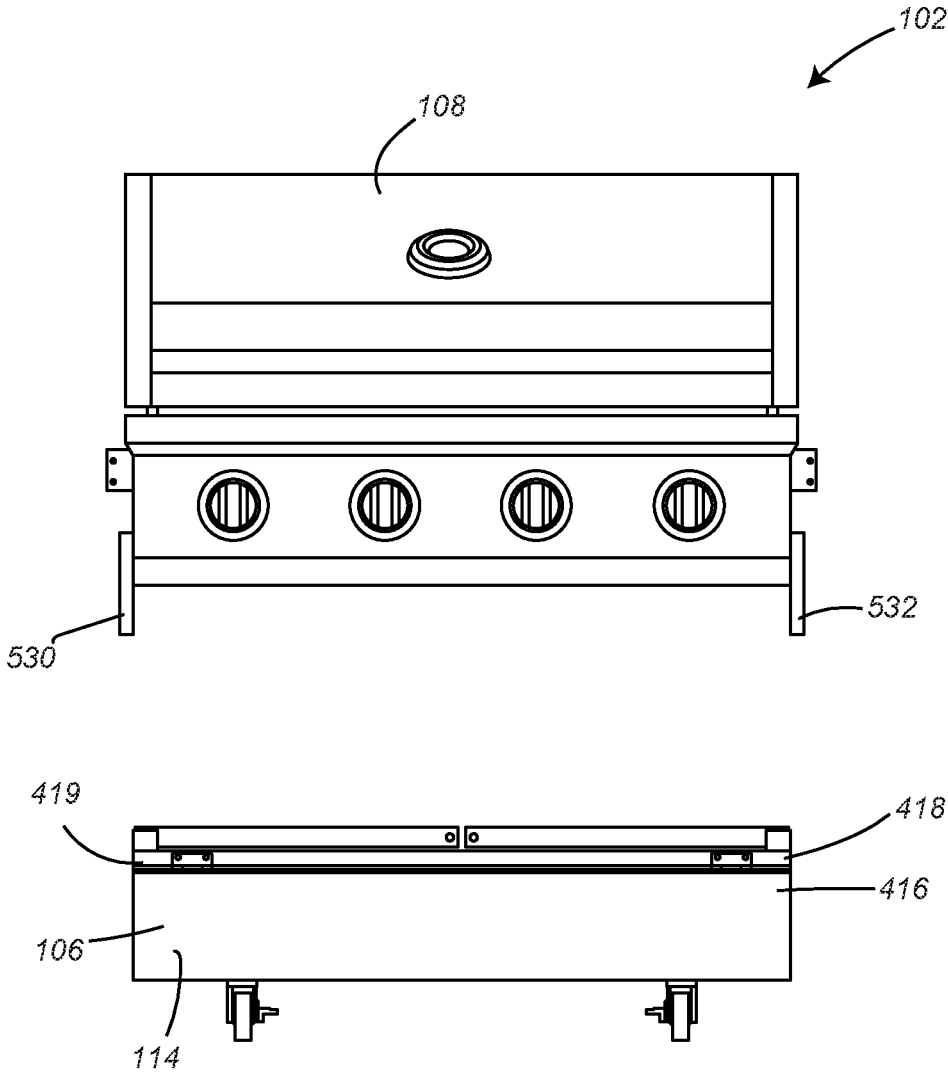

FIG. 8

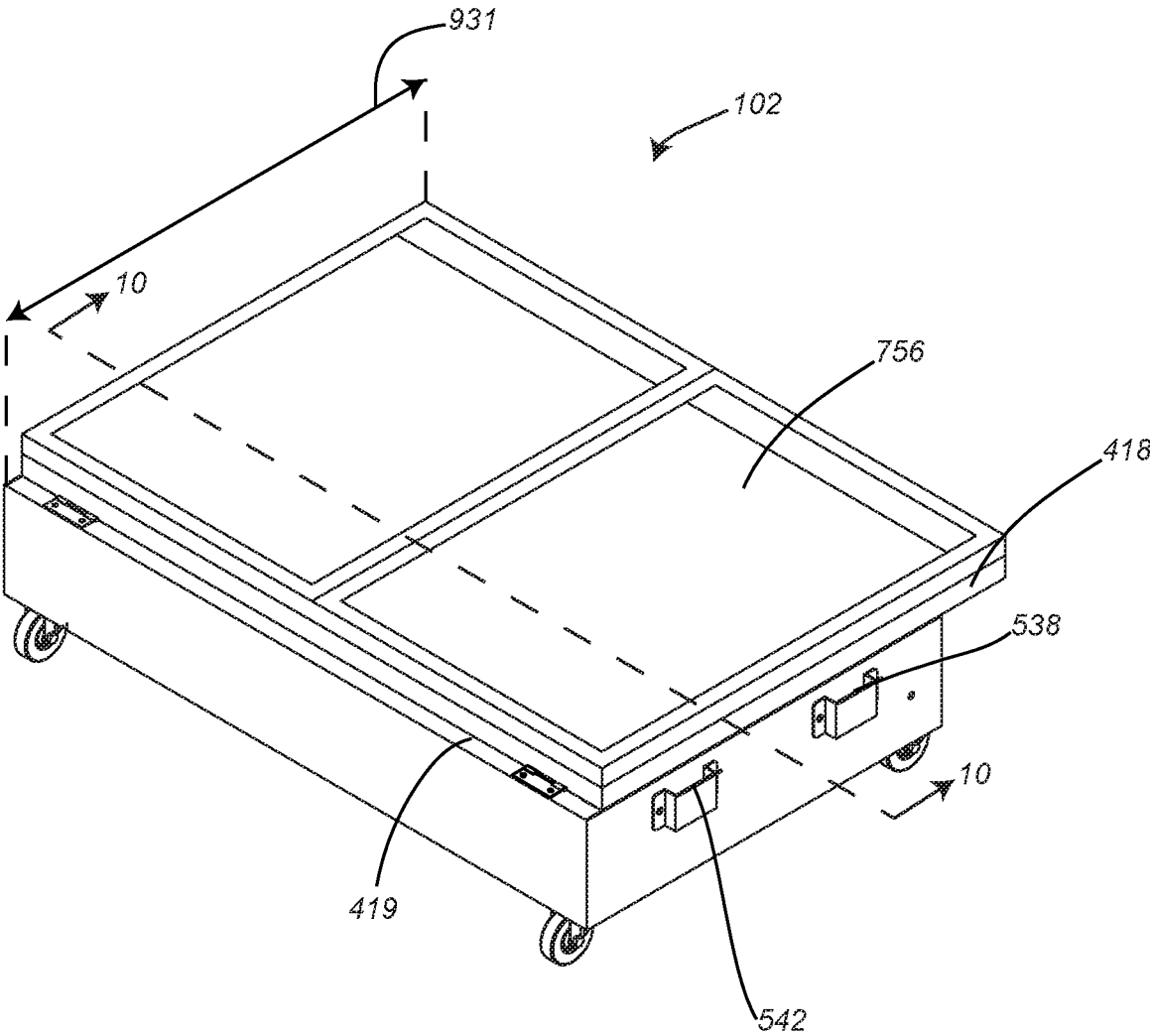

FIG. 9

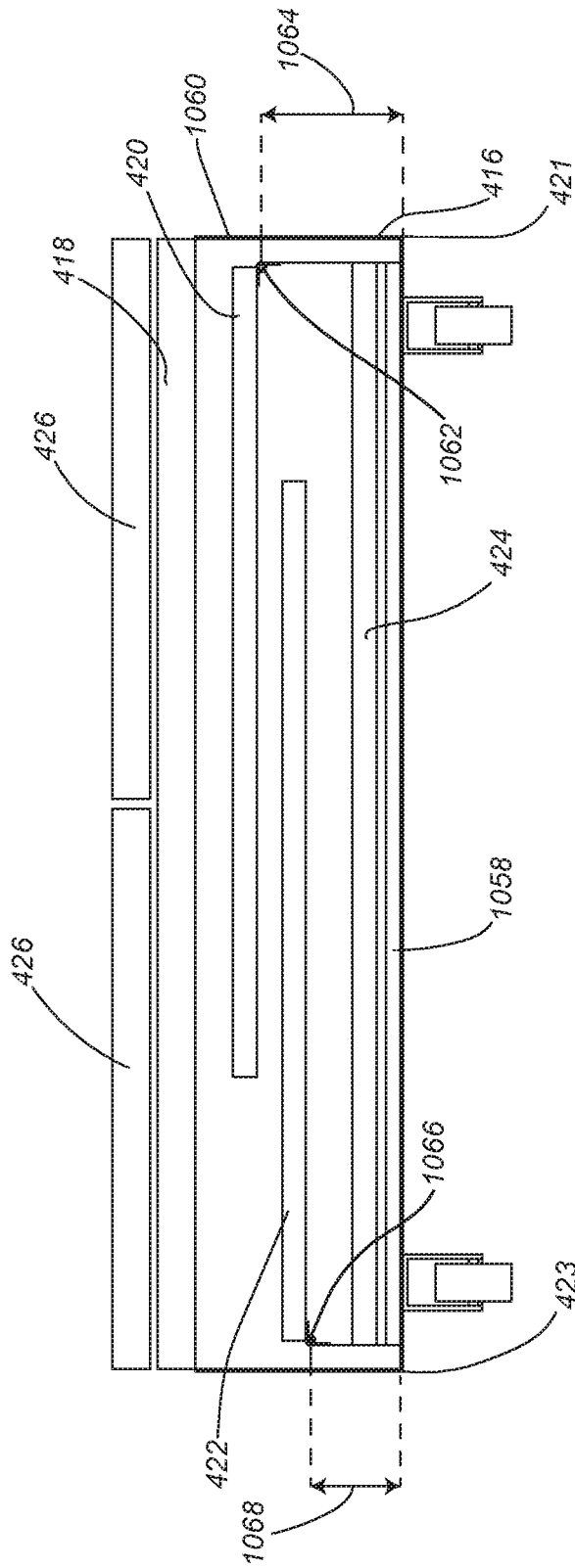

FIG. 10

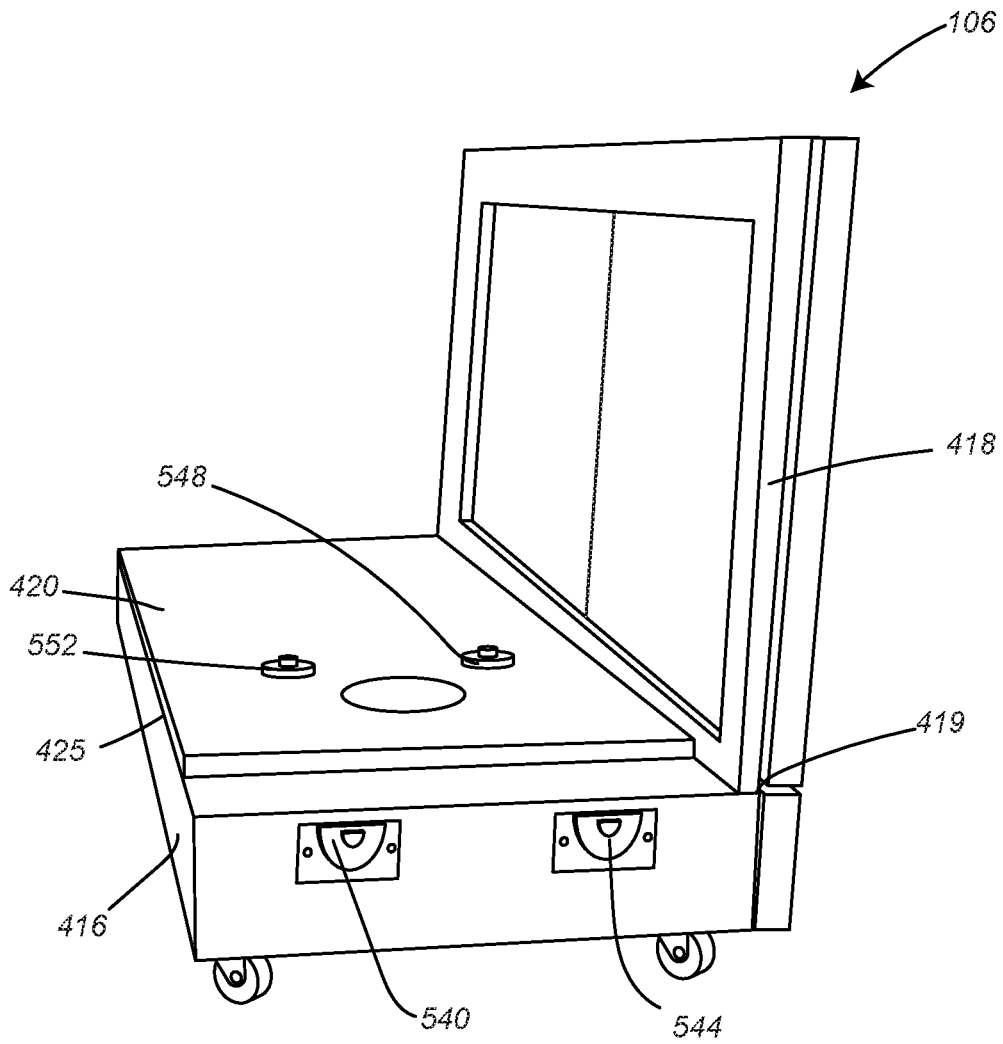

FIG. 11

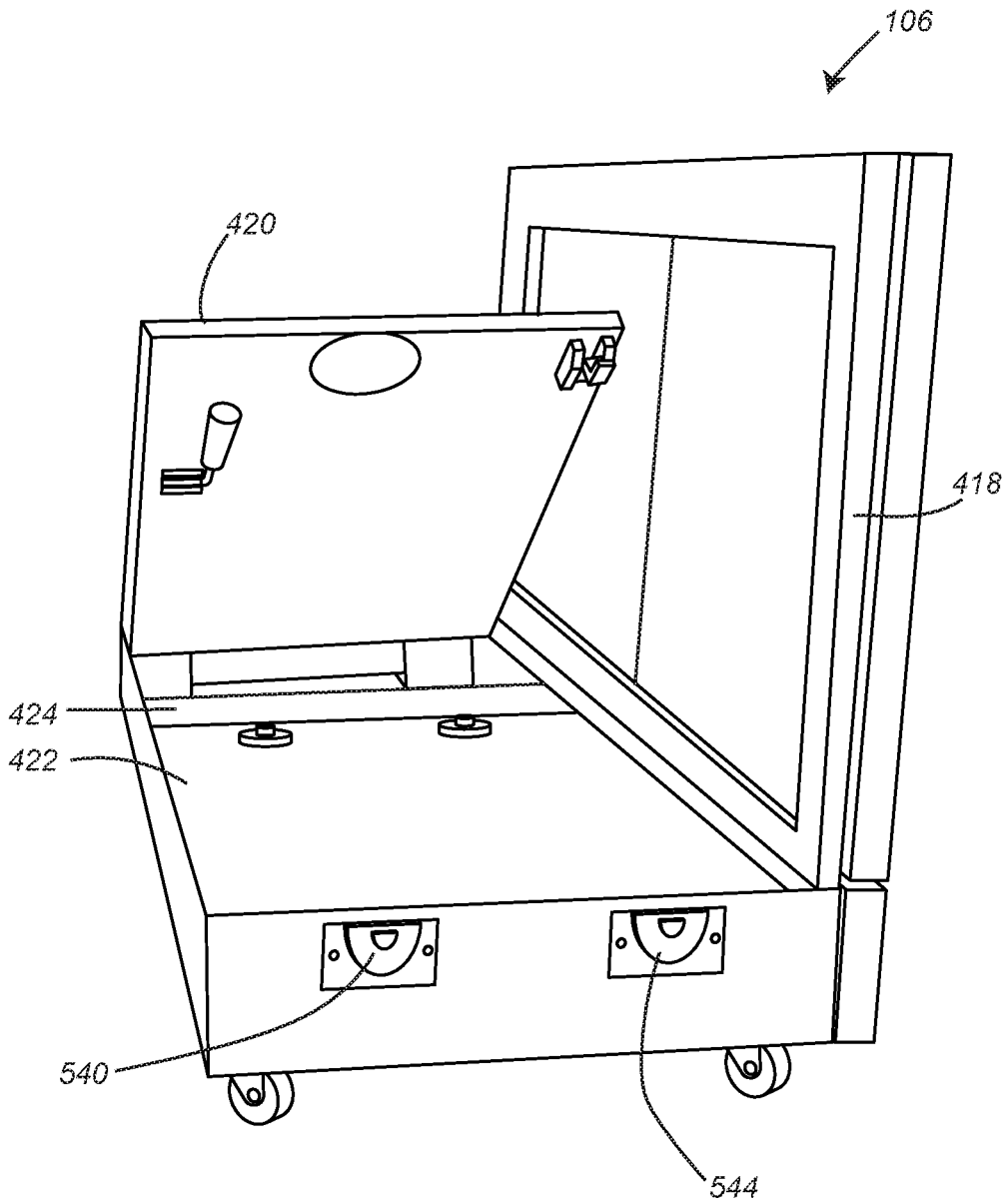

FIG. 12

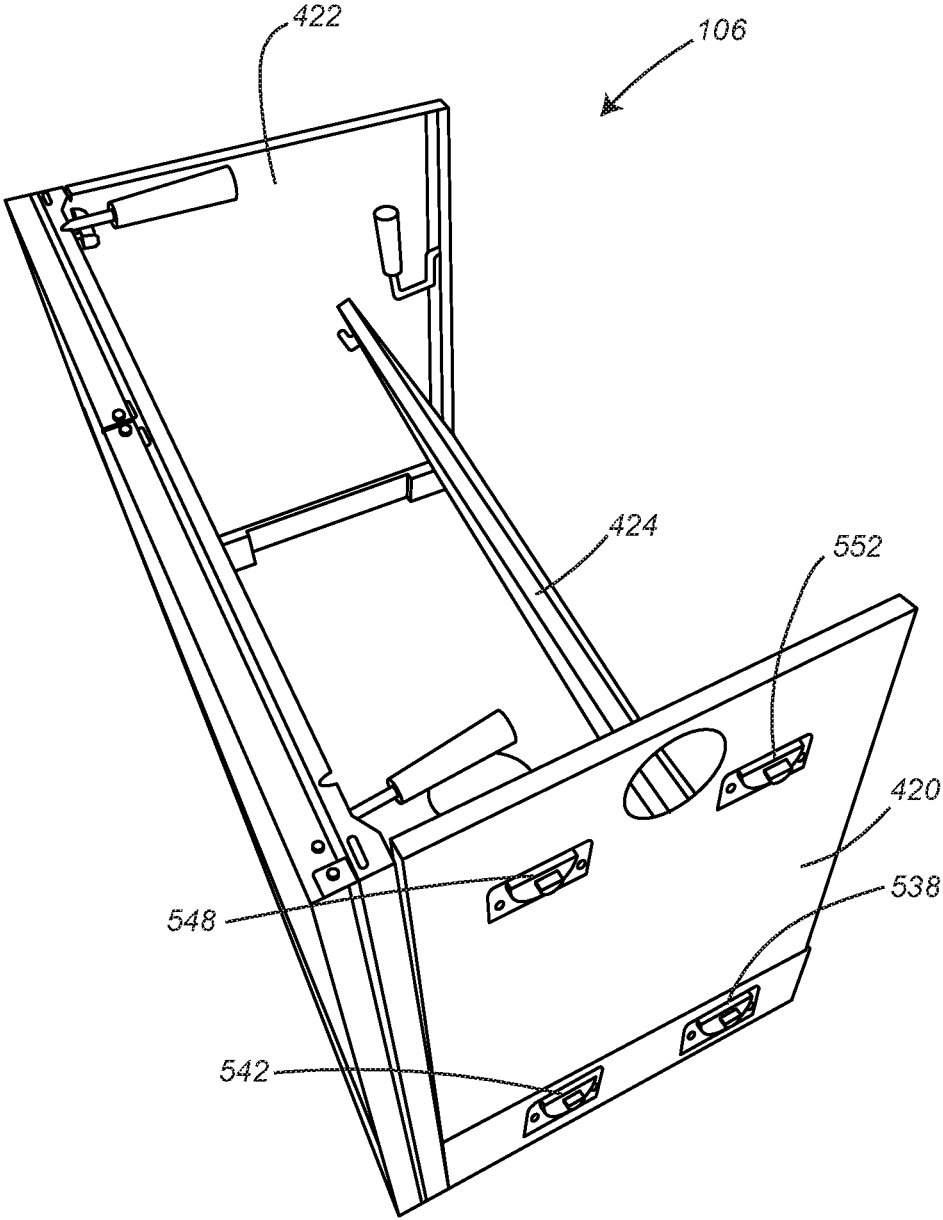

FIG. 13

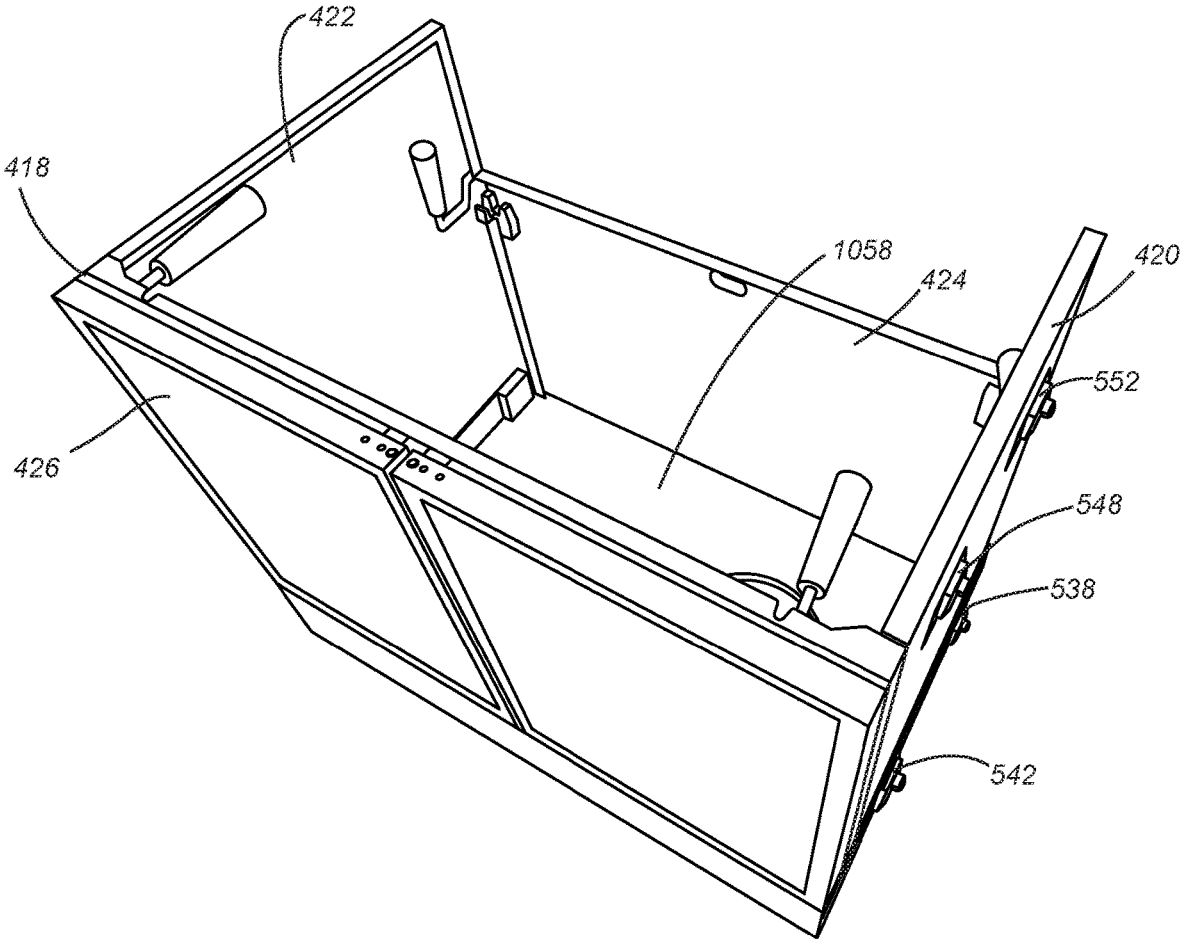

FIG. 14

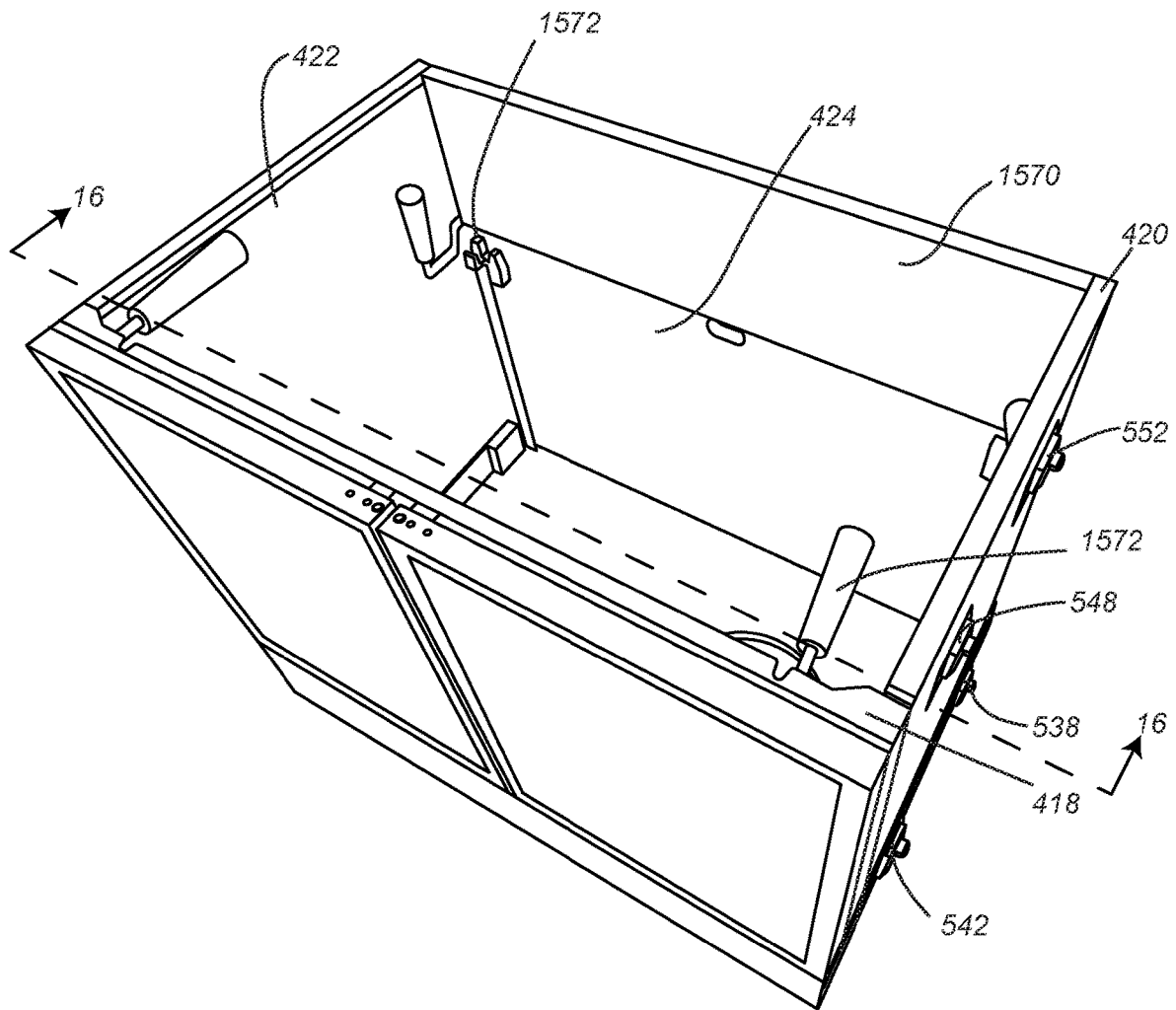

FIG. 15

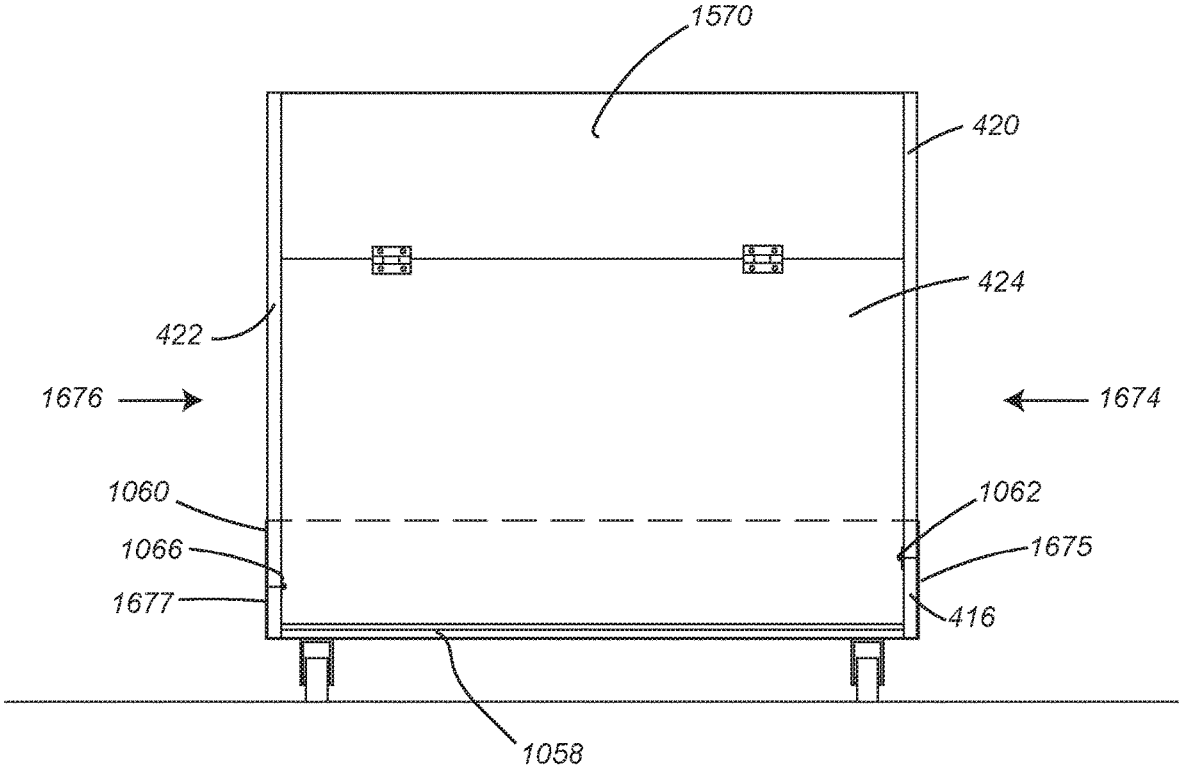

FIG. 16

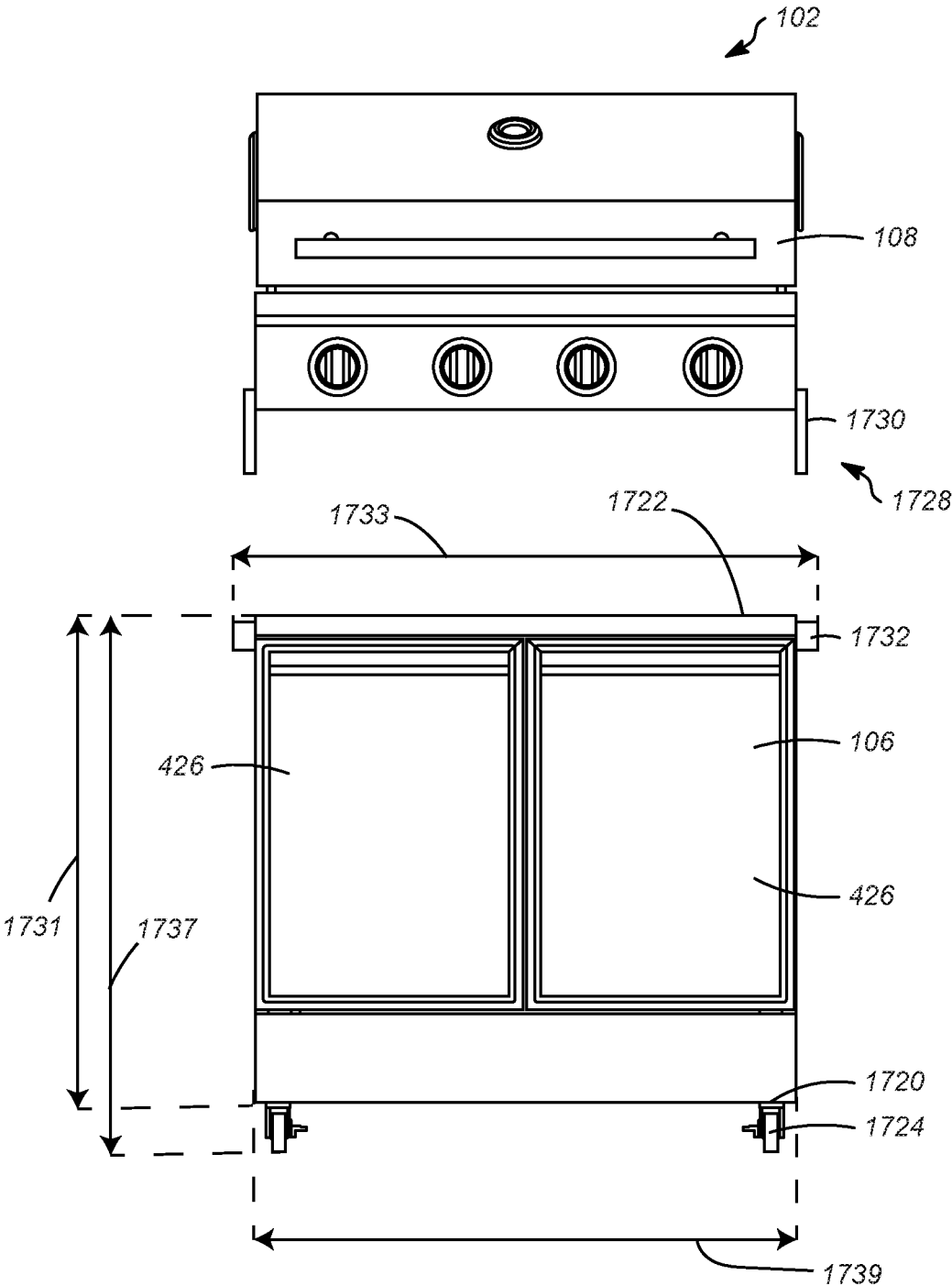

FIG. 17

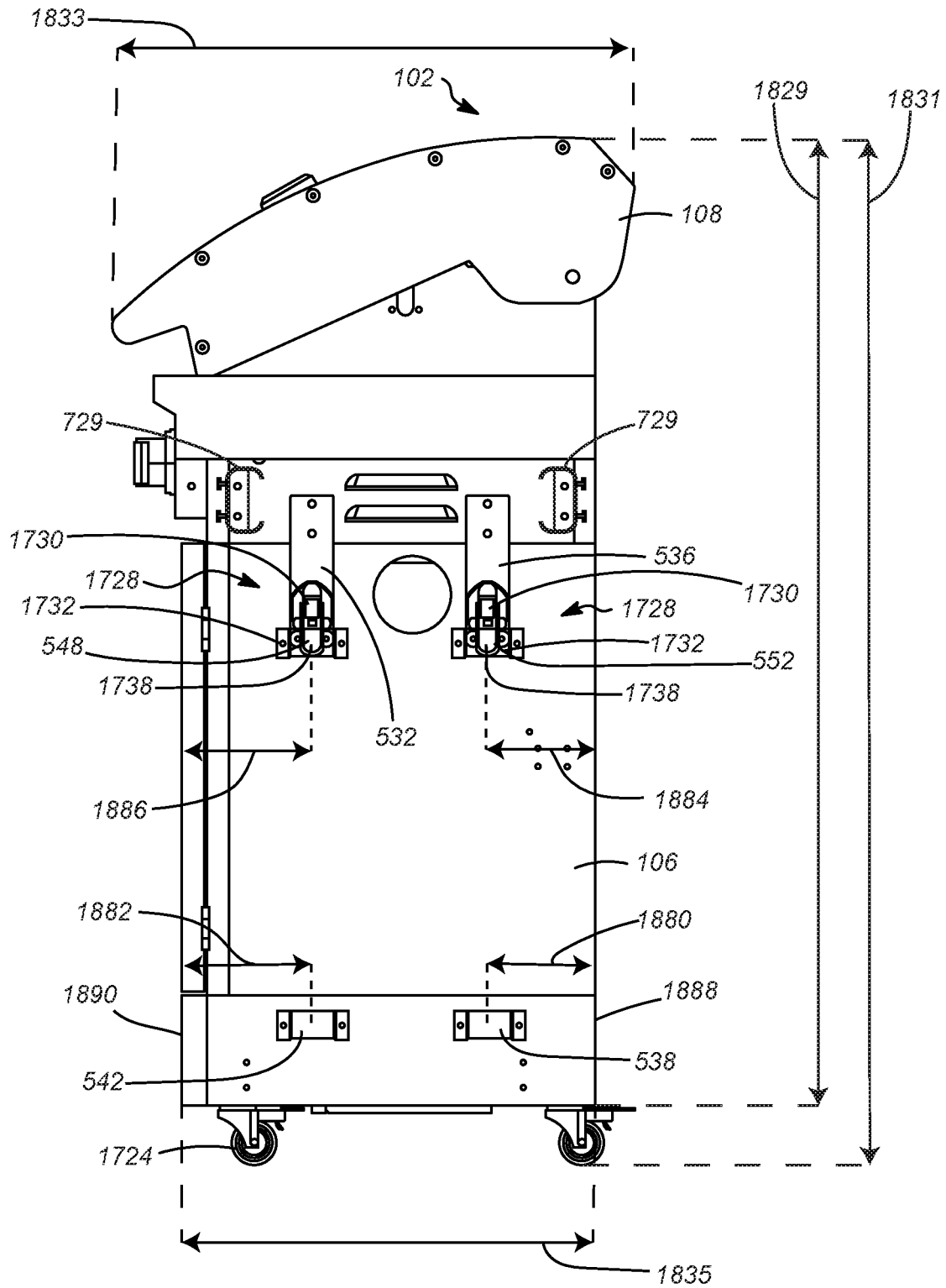

FIG. 18

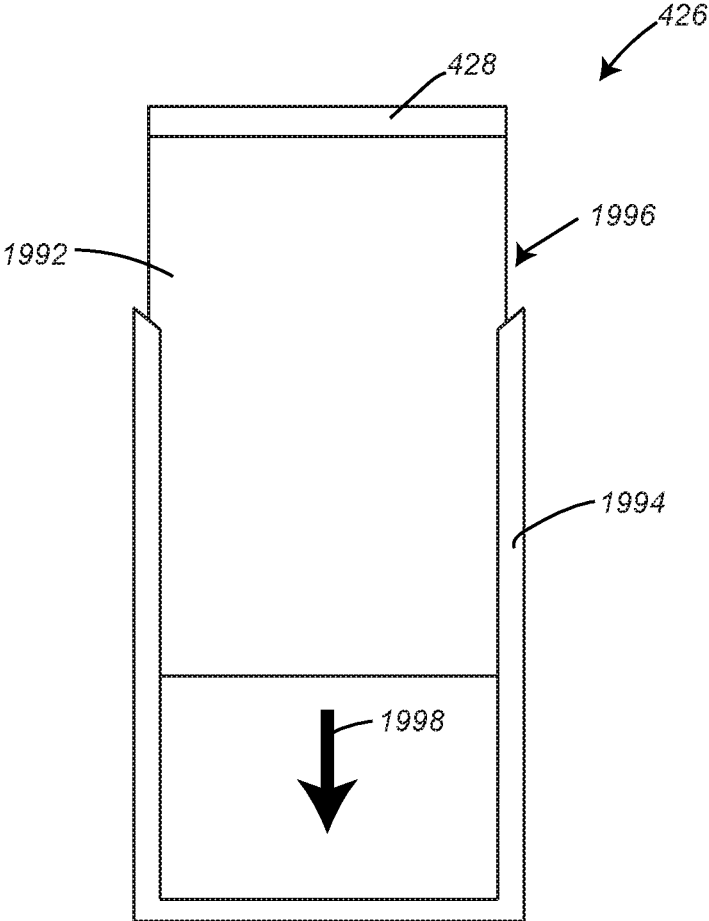

FIG. 19

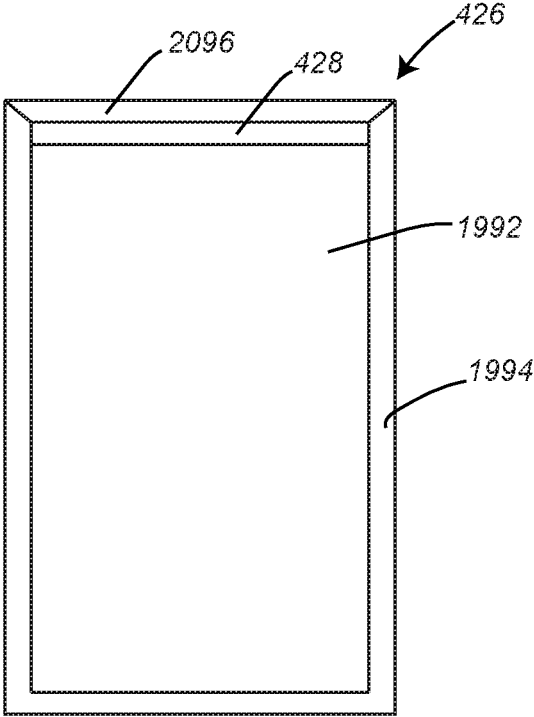

FIG. 20

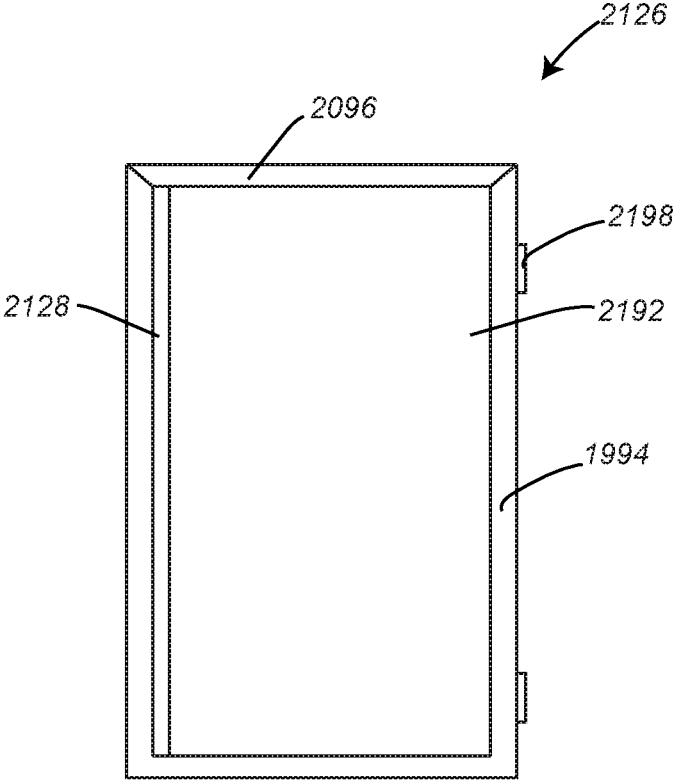

FIG. 21

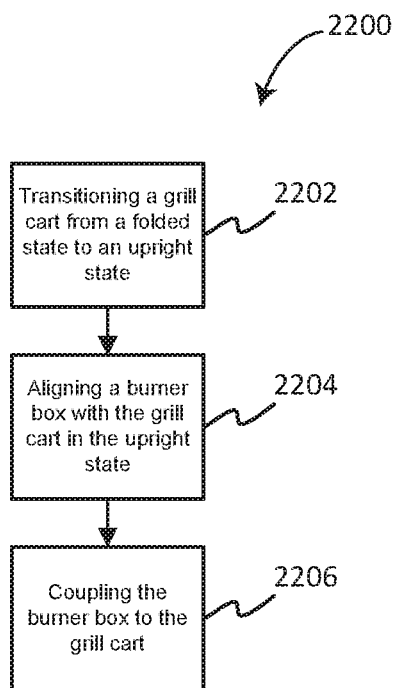

FIG. 22

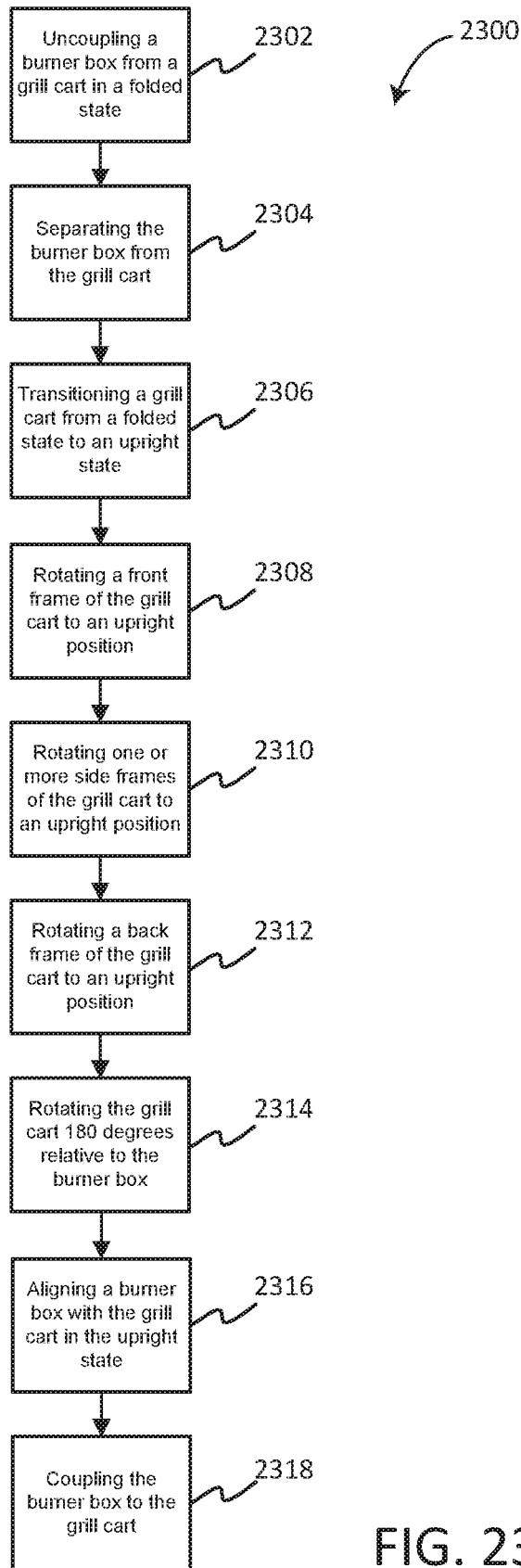

FIG. 23

GRILL ASSEMBLY WITH FOLDABLE CART

CLAIM OF PRIORITY

This application claims the benefit of U.S. Provisional Application No. 62/690,700, filed Jun. 27, 2018, the content of which is herein incorporated by reference in its entirety.

REFERENCE TO RELATED APPLICATIONS

The following five nonprovisional applications also claim priority to U.S. Provisional Application No. 62/690,700, are co-owned, and are filed on the event date herewith: U.S. application Ser. No. 16/450,303, titled, "Grill and Side Cart Attachment Systems and Methods,,"; U.S. application Ser. No. 16/450,356, titled, "Securing of Panels to Grill System,,"; U.S. application Ser. No. 16/450,388, titled, "Grill System with Decorative Panels,,"; U.S. application Ser. No. 16/450,493, titled, "Gas Guard in Grill Cart,,"; and U.S. application Ser. No. 16/450,510, titled, "Side Cart Locking Mechanism,,"; the contents of which for each application are herein incorporated by reference in their entirety. The following four design applications are co-owned and are filed on the event date herewith: U.S. Design Application No. 29/695,966, titled, "Grill System,,"; U.S. Design Application No. 29/695,969, titled, "Grill Assembly,,"; U.S. Design Application No. 29/695,973, titled, "Grill Cart,,"; U.S. Design Application No. 29/695,976, titled, "Side Assembly,,"; the contents of which for each application are herein incorporated by reference in their entirety.

FIELD

The present application relates to grills and outdoor cooking systems. More specifically, the present application relates to a grill assembly with a foldable cart.

BACKGROUND

Grilling is a cooking style that is especially popular in the United States. Grills are frequently not particularly portable or easy to set up. In many cases, grills are difficult to assemble due to numerous steps requiring the user to construct a frame with numerous components.

Attempts have been made to design grills that are easy to assemble after unloading from shipping containers. However, in many past systems, grill systems include a large number of pieces, require numerous steps to assemble, and some assembly steps require tools.

Some past systems mount a firebox on a foldable stand. However, the foldable stands can require complex set-up steps and, even in the folded configuration, some of the foldable stands take-up significant space.

Permanent outdoor grill installations are increasingly popular, and allow consumers to choose many finishes and options to create an attractive and functional outdoor kitchen environment. These installations are very expensive, and lack the flexibility of a moveable grill system.

SUMMARY

In an embodiment, a grill is provided. The grill can include a grill cart and a burner box. The grill cart configured to be transitioned between an upright state and a folded state. The burner box configured to be detachably coupled to the grill cart in the upright state. The grill cart includes: a base; a front frame coupled to a first side of the base in the upright

state and the folded state; a back frame coupled to a second side of the base in the upright state and the folded state; a first side frame coupled to a third side of the base in the upright state and the folded state; a second side frame coupled to a fourth side of the base in the upright state and the folded state. The coupling between the first side frame and the base is located in a first plane that is substantially parallel with a plane defined by a bottom plate of the base, and the coupling between the second side frame and the bottom plate of the base is located in a second plane that is substantially parallel with the plane defined by the bottom plate. The first plane is located a first distance away from the plane defined by the bottom plate and the second plane is located a second distance away from the plane defined by the bottom plate. The first distance is not equivalent to the second distance.

In an embodiment, in the upright state, the front frame, the back frame, the first side frame, and the second side frame are substantially perpendicular to the base.

In an embodiment, in the folded state, the first side frame overlaps the second side frame.

In an embodiment, in the folded state, the front frame overlaps the back frame.

In an embodiment, in the folded state the front frame, the back frame, the first side frame, and the second side frame are substantially parallel with the base, and at least one of the first side frame and the second side frame are disposed between the front frame and the back frame.

In an embodiment, in a first outer side of the grill is defined by a first side portion of the base and a portion of the first side frame and a second outer side of the grill is defined by a second side portion of the base and a portion of the second side frame.

In an embodiment, the grill in the folded state has a volume of no more than 42,000 inches³.

In an embodiment, the burner box includes: a first projection extending from the burner box; and a second projection extending from the burner box. In the folded state, the grill is configured such that the first projection is disposed in a first aperture defined by the base and the second projection is disposed in a second aperture defined by the base; wherein in the upright state the grill is configured such that the first projection is disposed in a third aperture defined by the first side frame and the second projection is disposed in a fourth aperture defined by the second side frame.

In an embodiment, a grill is provided. The grill can include a grill cart and a burner box. The grill cart can be configured to be transitioned between an upright state and a folded state. The burner box can be detachably coupled to the grill cart in both the upright state and the folded state. The grill cart includes: a base; a front frame rotatably coupled to a first side of the base; a back frame rotatably coupled to a second side of the base; a first side frame rotatably coupled to a third side of the base; and a second side frame rotatably coupled to a fourth side of the base.

In an embodiment, the burner box includes: a first projection extending from the burner box; and a second projection extending from the burner box. In the folded state, the grill is configured such that the first projection is disposed in a first aperture defined by the base and the second projection is disposed in a second aperture defined by the base. In the upright state, the grill is configured such that the first projection is disposed in a third aperture defined by the first side frame and the second projection is disposed in a fourth aperture defined by the second side frame.

3

In an embodiment, the first aperture and the fourth aperture are located on the same side of the grill cart, and the second aperture and the third aperture are located on the same side of the grill cart.

In an embodiment, the back frame includes a first portion coupled to a second portion. The first portion is coplanar with the second portion in the upright state. The first portion is coupled to the back portion via a piano hinge, a butt joint, or a telescope arrangement.

In an embodiment, a method of assembling a grill is provided. The method can include transitioning the grill cart from the folded state to an upright state, which can include rotating a front frame of the grill cart from a first position where the front frame is substantially parallel to a base of the grill cart to a second position where the front frame is substantially perpendicular to the base. The front frame is rotatably coupled to the base. The method can further include aligning a burner box with the grill cart in the upright state; and coupling the burner box to the grill cart in the upright state.

In an embodiment, the method can further include: uncoupling the burner box from the grill cart while the grill cart is in the folded state; and separating the burner box from the grill cart while the grill cart is in the folded state.

In an embodiment, separating the burner box from the cart in the folded state includes removing a first projection of the burner box and a second projection of the burner box from a first aperture in a base of the grill cart and a second aperture in the base of the grill cart.

In an embodiment, coupling the burner box to the grill cart in the upright state includes inserting the first projection into a third aperture in the grill cart and inserting the second projection into a fourth aperture in the grill cart.

In an embodiment, the third aperture is defined by a portion of a first side frame, and the fourth aperture is defined by a portion of a second side frame.

In an embodiment, the method can further include rotating the grill cart 180 degrees relative to the burner box after separating the burner box from the grill cart.

In an embodiment, the front frame includes at least one door.

In an embodiment, transitioning the grill cart from the folded state to the upright state further includes moving a first side frame of the grill cart from a first position where the first side frame is substantially parallel to the base of the grill cart to a second position where the first side frame is substantially perpendicular to the base, and moving a second side frame of the grill cart from a first position where the second side frame is substantially parallel to the base to a second position where the second side frame is substantially perpendicular to the base.

In an embodiment, transitioning the grill cart from the folded state to the upright state further includes moving a back frame of the grill cart from a first position where the back frame is substantially parallel to the base to a second position where the back frame is substantially perpendicular to the base.

In an embodiment, the method can further include moving a second back frame to a position in which the second back frame is coplanar with the back frame.

This summary is an overview of some of the teachings of the present application and is not intended to be an exclusive or exhaustive treatment of the present subject matter. Further details are found in the detailed description and appended claims. Other aspects will be apparent to persons skilled in the art upon reading and understanding the following detailed description and viewing the drawings that form a

4

part thereof, each of which is not to be taken in a limiting sense. The scope herein is defined by the appended claims and their legal equivalents.

BRIEF DESCRIPTION OF THE FIGURES

Aspects may be more completely understood in connection with the following figures (FIGS.), in which:

FIG. 1 is a front view of a grill system in accordance with various embodiments herein.

FIG. 2 is a front view of a grill system in accordance with various embodiments herein.

FIG. 3 is a front view of a grill system in accordance with various embodiments herein.

FIG. 4 is a front view of a grill assembly in accordance with various embodiments herein.

FIG. 5 is a perspective view of a grill assembly with a grill cart in an upright state in accordance with various embodiments herein.

FIG. 6 is a perspective view of a grill assembly with a grill cart in a folded state in accordance with various embodiments herein.

FIG. 7 is a perspective view of a grill assembly with a grill cart in a folded state in accordance with various embodiments herein.

FIG. 8 is a perspective view of a grill assembly with a grill cart in a folded state in accordance with various embodiments herein.

FIG. 9 is a perspective view of a grill cart in a folded state in accordance with various embodiments herein.

FIG. 10 is a cross-sectional view of the grill cart in a folded state of FIG. 9 in accordance with various embodiments herein.

FIG. 11 is a perspective view of a grill cart with a front frame in an upright state in accordance with various embodiments herein.

FIG. 12 is a perspective view of a grill cart with a first side frame in a partially upright state in accordance with various embodiments herein.

FIG. 13 is a perspective view of a grill cart with a back frame in a partially upright state in accordance with various embodiments herein.

FIG. 14 is a perspective view of a grill cart in an upright state in accordance with various embodiments herein.

FIG. 15 is a perspective view of a grill cart in an upright state in accordance with various embodiments herein.

FIG. 16 is a cross-section view of the grill cart in an upright state in FIG. 15 in accordance with various embodiments herein.

FIG. 17 is a front view of a grill assembly with a grill cart in an upright state in accordance with various embodiments herein.

FIG. 18 is a side view of a grill assembly with a grill cart in an upright state in accordance with various embodiments herein.

FIG. 19 is a front view of a door being assembled in accordance with various embodiment herein.

FIG. 20 is a front view of a door in accordance with various embodiment herein.

FIG. 21 is a front view of a door in accordance with various embodiment herein.

FIG. 22 is a flow chart depicting a method in accordance with various embodiments herein.

FIG. 23 is a flow chart depicting a method in accordance with various embodiments herein.

While embodiments are susceptible to various modifications and alternative forms, specifics thereof have been

shown by way of example and drawings, and will be described in detail. It should be understood, however, that the scope herein is not limited to the particular aspects described. On the contrary, the intention is to cover modifications, equivalents, and alternatives falling within the spirit and scope herein.

DETAILED DESCRIPTION

Described below and shown in the figures are various embodiments of components that can be included in a grill system. The grill system can include a grill assembly and one or more side assemblies. The grill assembly can include a burner box, which can be used to cook foods, such as meats and vegetables. Each side assembly can include a functional top cap to provide additional functionality to the grill system.

The grill and side assemblies can be shipped or transported in a folded configuration. In the folded configuration, the grill and side assemblies can have a smaller volume compared to the upright configurations. The smaller volume can reduce the cost of storing and transporting the components.

The grill and side assemblies described herein can be easily assembled. In many cases, the grill and side assemblies can be assembled by a single user or only two users. In many examples, the grill and side assemblies can be assembled without the use of tools. In many examples, the grill and side assemblies can be assembled quickly, such as in less than three minutes for each component. In many examples, the grill systems described herein can provide a highly customizable, an easily assembled, and an easily installed outdoor kitchen environment.

Grill System with Grill Assembly and Side Assemblies

The figures show various views and embodiments of grill systems and components. FIG. 1 shows a grill system 100 including a grill assembly 102 and a side assembly 104. The grill assembly 102 can include a grill cart 106 and a burner box 108 (also referred to as a "firebox") coupled to a top portion of the grill cart 106. The side assembly 104 can include a side cart 110 and a top cap 112. The top cap 112 can be coupled to a top portion of the side cart 110.

FIG. 2 shows a front view of a grill system 100 in accordance with various embodiments herein. In some embodiments, the grill system 100 can include a grill assembly 102, and two or more side assemblies 104. Each of the side assemblies 104 can include a side cart 110 and a top cap 112. In some embodiments, the side assemblies 104 can be disposed on opposite sides of the grill assembly 102, such as shown in FIG. 2. In some embodiments, the side assemblies 104 can be disposed on the same side of the grill assembly 102, such as shown in FIG. 3. In other embodiments, the grill system 100 can include additional side assemblies 104, such as three, four, five, six, or more side assemblies 104.

In some embodiments, all of the side assemblies 104 can be located on one side of the grill assembly 102, such as shown in FIG. 3. In some embodiments, side assemblies 104 can be located on both sides of the grill assembly 102, such as shown in FIG. 2. In some embodiments, an equal number of side assemblies 104 can be located on either side of the grill assembly 102. In some embodiments, the number of side assemblies 104 on one side of the grill assembly 102 can be greater than or less than the number of side assemblies 104 on the other side of the grill assembly 102.

In various embodiments, the burner box 108 can include a first connection structure, and the top cap 112 can include

a second connection structure. The first connection structure can be configured to mate with the second connection structure to couple the grill assembly 102 to the side assembly 104.

In some embodiments, the grill assembly 102 can include a toe kick panel 114. In some embodiments, the side assembly 104 can include a toe kick panel 114. In some embodiments, the toe kick panel 114 of the grill assembly 102 can include a connection feature and the toe kick panel 114 of the side assembly 104 can include a connection feature, such as two portions of a latch mechanism. The connection features of the two toe kick panels 114 can be coupled together to couple the grill assembly 102 with the side assembly 104. In some embodiments, the connection features of the toe kick panels 114 can be like other connection mechanisms described herein, such as the connection mechanism for coupling the burner box 108 to the grill cart 106.

In some embodiments, the grill cart 106 can include one or more panels on the sides of the grill cart 106. In some embodiments, the grill cart 106 can include a toe kick panel 114. In some embodiments, the toe kick panel 114 and the panel can include a common decorative design to provide a cohesive appearance.

Grill Assembly

In reference now to FIGS. 4 and 5, a front view of a grill assembly 102 with the grill cart 106 in the upright state is shown in FIG. 4 and a perspective view of the grill assembly 102 with the grill cart 106 in the upright state is shown in FIG. 5 in accordance with various embodiments herein. The grill assembly 102 can include a burner box 108 coupled to a top portion of a grill cart 106.

In various embodiments, the grill cart 106 can include a base portion 416, a front frame 418, a first side frame 420, a second side frame 422 and a back frame 424. In some embodiments, a frame can be a panel. In some embodiments, a frame can include a panel. In some embodiments, a frame can be configured to receive a panel. In some embodiments, a frame can be rectangular or include four sides. In some embodiments, a frame can define an opening or aperture, such as to receive a panel. In some embodiments, a frame can have an open side, such as to receive a panel. In some embodiments, a frame can provide a base structure for other components to be coupled to, such as a door or panel.

In some embodiments, one or more of the frames 418, 420, 422, 424 of the grill cart 106 have a frame bottom edge attached the base portion 416 and a frame top edge. In some embodiments, one or more of the frames 418, 420, 422, 424 have at least one embodiment that is a unitary piece as it extends from its bottom edge to its top edge. For example a perimeter frame or a panel can be unitary. In some embodiments, one or more of the frames 418, 420, 422, 424 does not fold or buckle between the top edge and the bottom edge. In various embodiments, one or more of the frames 418, 420, 422, 424 can be rigid, such that a portion of the frame does not rotate, twist, bend or otherwise move relative to other portions of the frame.

In various embodiments, the grill cart 106 can include a front frame 418 coupled to a first side of the base portion 416 in the upright state and the folded state. In various embodiments, the grill cart 106 can include a first side frame 420 coupled to a second side of the base portion 416 in the upright state and the folded state. In various embodiments, the grill cart 106 can include a second side frame 422 coupled to a third side of the base portion 416 in the upright state and the folded state. In various embodiments, the grill

cart **106** can include a back frame coupled to a fourth side of the base portion **416** in the upright state and the folded state.

The front frame **418** can be rotatably coupled to the base portion **416** along a first or front edge **419** of the base portion **416**. The rotatable coupling can allow the front frame **418** to rotate relative to the base portion **416**, such as from a folded position where the front frame **418** is substantially parallel with a bottom plate of the base portion **416** to an upright position where the front frame **418** is or substantially perpendicular to the bottom plate of the base portion **416**. Similarly, the first side frame **420** can be rotatably coupled to a second edge **421** of the base portion **416**, the second side frame **422** can be rotatably coupled to a third edge **423** of the base portion **416**, and the back frame **424** can be rotatably coupled to a fourth or back edge **425** of the base portion **416**. It should be understood that in some embodiments “coupled to an edge” can include being coupled along an edge, being coupled parallel or substantially parallel to an adjacent edge, or being coupled offset from an edge, such as shown in FIG. **10**.

In some embodiments, the front frame **418** can include at least one door **426**. In some embodiments, the front frame **418** can include two doors **426**. In some embodiments, a door **426** can include a door handle **428**, such as a horizontal recess. In some embodiments, the horizontal recess can be located at the top of the frame. In some embodiments, a door **426** can include a vertical recess for a door handle, such as a vertical recess that extends along a side of the door **426** opposite from the side of the door **426** that is coupled to the front frame **418**.

In various embodiments, the burner box **108** can include one or more projections for connecting with the grill cart **106**. In various embodiments, the grill cart **106** can define a plurality of apertures configured to receive the projections from the burner box **108**. In some embodiments, the number of projections on the burner box **108** can be equal to the number of apertures defined by the grill cart **106**. In some embodiments, the grill cart **106** can include one or more projections, and the burner box **108** can define one or more apertures configured to receive the projections from the grill cart **106**.

In some embodiments, the number of apertures defined by the grill cart **106** can be greater than the number of projections on the burner box **108**. In some embodiments, the number of apertures defined by the grill cart **106** can be at least twice as many than the number of projections on the burner box **108**, such as two projections and four apertures, or four projections and eight apertures. In some embodiments, a portion of the apertures can be defined by the base portion **416** and the remaining portion of the apertures can be defined by a portion of the front frame **418**, the first side frame **420**, the second side frame **422**, and the back frame **424**. In some embodiments, half of the apertures are defined by the base portion **416** and half of the apertures are defined by the front frame **418**, the first side frame **420**, the second side frame **422**, and the back frame **424**. In some embodiments, half of the apertures can be defined by the base portion **416**, a quarter of the apertures are defined by the first side frame **420**, and a quarter of the apertures are defined by the second side frame **422**.

In some embodiments, the burner box **108** can include four projections, such as first projection **530**, a second projection **532**, a third projection **534**, and a fourth projection **536**. The first projection **530** and the third projection **534** can be located on the same side of the burner box **108**, such as shown in FIG. **5**. Similarly, the second projection

532 and the fourth projection **536** can be located on the same side of the burner box **108** opposite from the side with the first projection **530** and the third projection **534**, such as shown in FIG. **6**.

In some embodiments, the grill cart **106** can define eight apertures, such as a first aperture **538**, a second aperture **540**, a third aperture **542**, a fourth aperture **544**, a fifth aperture **546**, a sixth aperture **548**, a seventh aperture **550**, and an eighth aperture **552**. In various embodiments, the first aperture **538**, the second aperture **540**, the third aperture **542**, and the fourth aperture **544** can be defined by the base portion **416**. In various embodiments, the fifth aperture **546**, the sixth aperture **548**, the seventh aperture **550**, and the eighth aperture **552** can be defined by the first side frame **420** and the second side frame **422**.

In some embodiments, the first aperture **538** and the third aperture **542** can be located on the same side of the base portion **416**, such as shown in FIG. **9**. In some embodiments, the second aperture **540** and the fourth aperture **544** can be located on the same side of the base portion **416**, such as shown in FIG. **5**. In some embodiments, the fifth aperture **546** and the seventh aperture **550** can be located on the same side frame, such as shown in FIG. **5**. In some embodiments, the sixth aperture **548** and the eighth aperture **552** can be located on the same side frame, such as shown in FIG. **13**.

In some embodiments, the first projection **530** can be configured to be disposed at least partially within the first aperture **538** to couple the burner box **108** to the grill cart **106** in a folded state. Further, the second projection **532** can be disposed at least partially within the second aperture **540**, the third projection **534** can be disposed at least partially within the third aperture **542**, and the fourth projection **536** can be disposed at least partially within the fourth aperture **544**.

In some embodiments, the first projection **530** can be configured to be disposed at least partially within the fifth aperture **546** to couple the burner box **108** to the grill cart **106** in the upright state. Further, the second projection **532** can be disposed at least partially within the sixth aperture **548**, the third projection **534** can be disposed at least partially within the seventh aperture **550**, and the fourth projection **536** can be disposed at least partially within the eighth aperture **552** to couple the burner box **108** to the grill cart **106** in the upright state.

Conversion from Folded to Upright State

As mentioned above, the grill cart **106** can be configured to transition between a folded state and an upright state. FIGS. **6-18** show various steps of transitioning a grill assembly **102** from a folded state to an upright state. FIGS. **22** and **23** are flowcharts showing method steps involved in assembling the grill assembly from a folded state to an upright state, in some embodiments. In some embodiments, the steps shown in FIGS. **6-18**, FIG. **22** and FIG. **23** can be reversed, such as to transition the grill cart to a folded state from an upright state. In various embodiments, the transition from a folded state to an upright state can be accomplished without the use of any tools. In various embodiments, the reverse transition from an upright state to a folded state can be accomplished without the use of any tools. In various embodiments, the transition from a folded state to an upright state can be accomplished in less than 5 or 10 minutes. In various embodiments, the reverse transition from an upright state to a folded state can be accomplished in less than 5 or 10 minutes. In various embodiments, the transition from a folded state to an upright state can be accomplished by one

person. In various embodiments, the reverse transition from an upright state to a folded state can be accomplished by one person.

In a folded state, a frame can be parallel or substantially parallel with the bottom plate **1058**, such as shown in FIG. **6**. In an upright state, a frame can be perpendicular or substantially perpendicular with the bottom plate **1058**, such as shown in FIG. **16**.

In various embodiments, the burner box **108** can be coupled to the grill cart **106** when the grill cart **106** is in the folded state, such as shown in FIG. **6**. The burner box **108** can also be coupled to the grill cart **106** when the grill cart **106** is in the upright state, such as shown in FIGS. **1-4**.

FIG. **6** is a perspective view of a grill assembly **102** in accordance with various embodiments herein. The grill assembly **102** can include a grill cart **106** and a burner box **108**. In some embodiments, the burner box **108** can be configured to be detachably coupled to the grill cart **106** in both the upright state and the folded state. FIG. **6** shows an embodiment of a grill assembly **102** with the burner box **108** coupled to the grill cart **106** in the folded state. Coupling the burner box **108** to the grill cart **106** in the folded state can reduce the overall size of the grill assembly **102**, such as to make transportation or storage of the grill assembly **102** easier.

Examples of dimensions of the grill assembly **102** and components of the grill assembly **102** in a folded state and an upright state will now be described with respect to FIGS. **6, 7, 9, 17** and **18**. Now referring to FIG. **7**, in various embodiments, the burner box **108** can have a height **755**, without projections **530, 532**, of at least 15 inches and not more than 25 inches, such as about 19 inches. In various embodiments, the burner box **108** can have a height **739** including the projections **530, 532** of at least 20 inches and not more than 30 inches, such as about 23½ inches. In some embodiments, the burner box **108** can have a width **757**, without brackets **729**, of at least 25 inches and not more than 40 inches, such as about 31 inches. In various embodiments, the burner box **108** can have a width **737** with the brackets **729** of at least 30 inches and not more than 48 inches, such as about 35 inches. The brackets **729** can be configured to attach the burner box to a side assembly. Now referring to FIG. **18**, in various embodiments, the burner box **108** can have a depth **1833** of at least 20 inches and not more than 30 inches, such as about 24 inches.

Now referring to FIG. **7**, in various embodiments, the grill cart **106**, in the folded state, can have a height **759**, not including the wheels **1724**, of at least 5 inches and not more than 10 inches, such as about 7 inches. In various embodiments, the grill cart **106**, in the folded state, can have a height **741** of at least 5 inches and not more than 15 inches, such as about 10 inches. In various embodiments, the grill cart **106**, in the folded state, can have a width **761**, not including the portions that define the apertures **538, 540, 542, 544**, of at least 25 inches and not more than 35 inches, such as about 30 inches. In various embodiment, the grill cart **106**, in the folded state, can have a width **735** including the portions that define the apertures **538, 540, 542, 544** of at least 25 inches and not more than 35 inches, such as about 31½ inches. Now referring to FIG. **9**, in various embodiments, the grill cart **106**, in the folded state, can have a depth **931** of at least 18 inches and not more than 28 inches, such as about 22½ inches.

Now referring to FIG. **17**, in various embodiments, the grill cart **106**, in the upright state, can have a height **1731**, not including the wheels **1724**, of at least 20 inches and not more than 30 inches, such as about 25½ inches. In various

embodiments, the grill cart **106**, in the upright state including the wheels **1724**, can have a height **1737** of at least 25 inches and not more than 33 inches, such as about 28½ inches. In various embodiments, the grill cart **106**, in the upright state, can have a width **1739**, without the portions **1732** that define the apertures, of at least 25 inches and not more than 35 inches, such as about 30 inches. In various embodiments, the grill cart **106**, in the upright state, can have a width **1733** including the portions **1732** that define apertures **546, 548, 550, 552** of at least 25 inches and not more than 37 inches, such as about 31½ inches. For simplicity, FIG. **17** does not illustrate the portions that define apertures **538, 540, 542, 544** on the base portion **416** of the grill cart. Now referring to FIG. **18**, in various embodiments, the grill cart **106**, in the upright state, can have a depth **1835** of at least 15 inches and not more than 25 inches, such as about 19½ inches.

Now referring to FIG. **6**, in various embodiments, the grill assembly **102**, in the folded state, can have a height **633**, not including the wheels **1724**, of at least 20 inches and not more than 30 inches, such as about 26¾ inches. In various embodiments, the grill assembly **102**, in the folded state, can have a height, including the wheels, of at least 25 inches and not more than 35 inches, such as about 29½ inches. In various embodiments, the grill assembly **102**, in the folded state, can have a width **635** identical to the width of the burner box alone, where the brackets **729** of the burner box define its widest point, as described herein with respect to FIG. **7**. For simplicity of illustration, the brackets **729** are not shown in FIG. **6** or **17**. In various embodiment, the grill assembly **102**, in the folded state, can have a depth **631** of at least 20 inches and not more than 30 inches, such as about 24½ inches.

Now referring to FIG. **18**, in various embodiments, the grill assembly **102**, in the upright state, can have a height **1831**, of at least 40 inches and not more than 55 inches, such as about 47½ inches. In various embodiments, the grill assembly **102**, in the upright state, can have a height **1829**, not including the wheels **1724**, of at least 38 inches and not more than 53 inches, such as about 44½ inches.

In various embodiments, the grill assembly **102** includes a burner box **108** coupled to a grill cart **106** in a folded state can have a maximum volume of 42,000 inches³ and a minimum volume of 15,000 inches³, such as about 25300 inches³. The grill assembly **102** can have a maximum volume of 42,000 inches³, such that the grill assembly **102** could fit into a rectangular prism (such as a box) with a minimum volume of 42,000 inches³. Similarly, the grill assembly **102** can have a minimum volume of 15,000 inches³, such that the grill assembly **102** could fit into a rectangular prism with a maximum volume of 15,000 inches³. In various embodiments, the wheels (shown in FIG. **17**) can be uncoupled or not attached in their intended locations on the bottom of the grill cart **106**, such as to reduce the volume of the grill assembly **102** when the grill cart **106** is in the folded state and the burner box **108** is coupled to the folded grill cart **106**. In other embodiments, the wheels can be coupled or attached to the bottom of the grill cart **106**, such as to make the assembly process of the grill system **100** easier.

In various embodiments, the front frame **418** can be coupled to a front edge **419** of the base portion **416**. In the folded state, the top edge of the front frame **418** (the edge that is not coupled to the base portion **416**) can extend past the fourth or back edge **425** of the base portion **416** which the back frame **424** is coupled to (as shown in FIG. **6**). In some embodiments, the front frame **418** extending past the

11

base portion **416** can be a result of the length of the front frame **418** being greater than the depth of the base portion **416**. The front face **654** of the burner box **108** can be aligned with the top edge of the front frame **418**. In various embodiments the front face **654** can include control elements **655**, such as to control the temperature level inside the burner box **108**. In various embodiments, the front face **654** can include an opening to access the interior of the burner box **108**. In some embodiments, the front face **654** can include a handle **657**, such as to be used to open the burner box **108**. In some embodiments the front face **654** can include a temperature gauge **659**.

In various embodiments, the burner box **108** can be uncoupled from the grill cart **106**, such as shown in FIG. 7. FIG. 7 shows the burner box **108** uncoupled and separated from the folded grill cart **106**, such as lifted up away from the grill cart **106**. In various embodiments, the burner box **108** can be separated from the folded grill cart **106** such that the either of the two components can be rotated or moved without affecting the other component.

In some embodiments, separating the burner box **108** from the grill cart **106** involves removing one or more projections extending from the burner box **108** from one or more apertures in the base portion **416** of the grill cart **106**. In an embodiment, separating the burner box **108** from the grill cart **106** in the folded state includes removing the first projection **530** of the burner box **108** and a second projection **532** of the burner box **108** from a first aperture **538** in the base portion **416** of the grill cart **106** and a second aperture **540** in the base portion **416** of the grill cart **106**.

The projections extending from the burner box **108** can be long enough such that the projections can be coupled to the base portion **416** of the grill cart **106** in the folded state, as well as to be coupled to the side frames **420**, **422** in the upright state.

In various embodiments, a top portion **756** of the folded grill cart **106** can be substantially planar or flat, such as to accommodate the bottom of the burner box **108** to be placed on. In some embodiments, the top portion **756** is free of projections that extend upwards or away from the top portion **756**, such that the burner box **108** is able to rest level on top of the folded grill cart **106**. In some embodiments, the top portion **756** of the folded grill cart **106** can include the front frame **418** of the grill cart **106**.

As mentioned above, when the burner box **108** is coupled to the grill cart **106** in the folded state, the front **654** of the burner box **108** can be aligned with the back of the base portion **416**. After the burner box **108** is uncoupled from the folded grill cart **106**, the burner box **108** can be rotated 180 degrees relative to the grill cart **106**, such as to align the front **654** of the burner box **108** with the front of the grill cart **106**. The 180 degree rotation of the burner box **108** relative to the grill cart **106** can be seen by comparing FIG. 7 with FIG. 8. In some embodiments, the burner box **108** can be rotated 180 degrees relative to the grill cart **106** when the grill cart **106** is in the folded state, when the grill cart **106** is in the upright state, or when the grill cart **106** is in a partially upright state.

FIG. 9 shows a perspective view of the grill cart **106** in the folded state in accordance with various embodiments. In various embodiments, the grill cart **106** in a folded state can have a maximum volume of 14,700 inches³ and a minimum volume of 2,250 inches³, such as about 7100 inches³. The grill cart **106** can have a maximum volume of 14,700 inches³, such that the grill cart **106** could fit into a rectangular prism (such as a box) with a minimum volume of 14,700 inches³. Similarly, the grill cart **106** can have a

12

minimum volume of 2,250 inches³, such that the grill cart **106** could fit into a rectangular prism with a maximum volume of 2,250 inches³.

FIG. 10 shows a cross-sectional view of the grill cart **106** taken along the line 10-10 of FIG. 9 in accordance with various embodiments herein. In some embodiments, the base portion **416** can include a bottom plate **1058** and an outer wall **1060**, where the outer wall **1060** includes four portions, one on each of the four sides of the bottom plate **1058**. In various embodiments, in a folded state the front frame **418** can be substantially parallel to the bottom plate **1058** of the base portion **416**. Similarly, in the folded state, one or more of the first side frame **420**, the second side frame **422**, and the back frame **424** can be substantially parallel with the bottom plate **1058**. In some embodiments, the first side frame **420**, the second side frame **422**, and the back frame **424** can all be substantially parallel with the bottom plate **1058**. In various embodiments, “substantially parallel” can refer to two components that are within 15 degrees of parallel, within 10 degrees of parallel, within 5 degrees of parallel, within 3 degrees of parallel, within 1 degree of parallel, or are parallel.

In some embodiments, the first side frame **420** and the second side frame **422** can be disposed between the front frame **418** and the back frame **424**. In some embodiments, the back frame **424** can be located underneath the second side frame **422**. In some embodiments, the second side frame **422** can be located underneath the first side frame **420**. In some embodiments, the first side frame **420** can be located underneath the front frame **418**.

In some embodiments, at least a portion of the front frame **418** overlaps at least a portion of the back frame **424**, such as at least a portion of the front frame **418** can be located above or below a portion of the back frame **424**. In some embodiments, at least a portion of the first side frame **420** overlaps at least a portion of the second side frame **422**, such as at least a portion of the first side frame **420** can be located above or below a portion of the second side frame **422**. In various embodiments, “overlap” can refer to two components being located in different horizontal planes but intersecting a common vertical plane. “Overlap” can refer to a component being located above or below another component.

In some embodiments, a gap can be disposed between two adjacent frames in the folded state, such as a gap between the first side frame **420** and the second side frame **422** as shown in FIG. 10. In some embodiments, the couplings **1062**, **1066** can prevent a frame from rotating past 90 degrees, such as to maintain the parallel or substantially parallel arrangement of the frames. In some embodiments, there is not a gap between two adjacent frames in the folded state, such as the first side frame **420** contacting and resting on the second side frame **422**.

In some embodiments, the base portion **416** can include an outer wall **1060** extending perpendicular or substantially perpendicular to the bottom plate **1058**. In some embodiments, the first side frame **420**, the second side frame **422**, and the back frame **424** can fit within the outer wall **1060**. In some embodiments, the outer wall **1060** can have a consistent height. In some embodiments, the outer wall **1060** can extend around the perimeter of the bottom plate **1058** and extends upward.

In some embodiments, the coupling **1062** between the first side frame **420** and the base portion **416** can be located in a first plane that is parallel with a plane defined by a bottom plate **1058** of the base. The first plane and the plane defined by the bottom plate **1058** can be a first distance **1064**

13

away from each other. The coupling **1066** between the second side frame **422** and the base portion **416** can be located in a second plane that is parallel with the plane defined by the bottom plate **1058**. The second plane and the plane defined by the bottom plate **1058** can be a second distance **1068** away from each other. The coupling **1062** and the coupling **1066** can both be located on the same side of the base portion **416**. In various embodiments, the first distance **1064** is not equivalent to the second distance **1068**. In some embodiments, the first distance **1064** is greater than the second distance **1068**, such as by an amount that is equivalent to the thickness of the second side frame **422**.

In various embodiments, the first side frame **420** and the second side frame **422** can be different heights to account for the difference between the first distance **1064** and the second distance **1068**. In various embodiments, in the upright state, the top of the first side frame **420** and the top of the second side frame **422** can be an equal distance away from the bottom plate **1058**. The difference in height of the first side frame **420** and the second side frame **422** can be equivalent to the difference between the first distance **1064** and the second distance **1068**.

FIGS. **11-15** depict an embodiment of the order in which the frames can be rotated into their upright positions. In some embodiments, the front frame **418** can be the first frame to be transitioned or rotated into its upright state, such that the remaining frames remain in their folded states. FIG. **11** shows a perspective view of a grill cart **106** with the front frame **418** in the upright state, and the remaining frames in the folded state. The grill cart **106** shown in FIG. **11** is in a configuration between a folded state and an upright state.

In some embodiments, the side frames **420, 422** can be transitioned or rotated into the upright state after the front frame **418**. In some embodiments, the first side frame **420** can be the second frame to be transitioned into the upright state. FIG. **12** shows the first side frame **420** being transitioned from the folded state to the upright state.

In various embodiments, the second side frame **422** can be transitioned or rotated into the upright state after the first side frame **420**. In some embodiments, the second side frame **422** can be the third frame to be transitioned into the upright state. FIG. **13** shows the front frame **418**, the first side frame **420**, and the second side frame **422** in the upright state.

FIG. **13** further shows the back frame **424** transitioning or rotating into the upright state after the second side frame **422**. In some embodiments, the back frame **424** can be the fourth or final frame to be transitioned into the upright state.

FIG. **14** shows a grill cart **106** in the upright state in accordance with various embodiments herein. The front frame **418**, the first side frame **420**, the second side frame **422**, and the back frame **424** are all in the upright state. The frames can be substantially perpendicular to the bottom plate **1058** of the base portion **416**. In various embodiments, "substantially perpendicular" can refer to two components that are within 15 degrees of perpendicular, within 10 degrees of perpendicular, within 5 degrees of perpendicular, within 3 degrees of perpendicular, within 1 degree of perpendicular, or are perpendicular.

In some embodiments, the back frame **424** can be shorter than the other frames, such as to allow the back frame **424** to not extend passed the coupling between the front frame **418** and the base portion **416** in the folded state. In some embodiments, the back frame **424** and the two side frames **420, 422** can define a void. In some embodiments, the void can be filled or occupied by a second back frame **1570** as shown in FIG. **15**. FIG. **15** is a perspective top view of a grill

14

cart **106** in an upright position with a second back frame **1570** attached to the first back frame **424**.

In various embodiments, the grill cart **106** can further include a second back frame **1570**. The second back frame **1570** can be moved to a position in which the second back frame **1570** is coplanar with the back frame **424**. In various embodiments, the second back frame **1570** can be coupled to the back frame **424**. In some embodiments, the first side frame **420** and the second side frame **422** can each define a slot, which the second back frame **1570** can be slide into and supported by. In some embodiments, the second back frame **1570** can be rotatably coupled to the back frame **424**, such as via a piano hinge as shown in FIG. **16**. In such embodiments, the second back frame **1570** can be rotated from a position where the second back frame **1570** is parallel or substantially parallel with the back frame **424** to a position where the second back frame **1570** is substantially co-planar with the back frame **424**. In other embodiments, the second back frame **1570** can expand or slide out from the back frame **424**, such as in a telescoping manner. In some embodiments, the second back frame **1570** can be coupled to the back frame **424** via a butt joint. It should be understood that FIG. **15** can represent the second back frame **1570** coupled to the back frame **424** via a butt joint or a telescope arrangement.

In various embodiments, the one or more of the frames **418, 420, 422, 424** can include locking elements **1572**, such as described in co-owned U.S. application Ser. No. 15/937,666, which is hereby incorporated by reference in its entirety. Once the grill cart **106** is in the upright state, the frames can be locked in the upright state via the locking elements **1572**. In some embodiments, the locking elements **1572** can provide a compression coupling, such that the locking elements **1572** provide a compressive force that pulls the frames together. In some embodiments, the locking elements **1572** can include hook on one frame, and a loop or a slot on an adjacent frame, such that the hook can mate with the loop or slot to couple the frames together. In some embodiments, the locking elements **1572** can include metal, such as to provide rigidity and strength to the coupling or locking of the frames in the upright state.

In reference now to FIG. **16**, a cross-section view of the grill cart **106** taken along line **16-16** in FIG. **15** is shown in accordance with various embodiments herein. In some embodiments, in the upright state, the first side frame **420** can be parallel or substantially parallel with the second side frame **422**. Similarly, the front frame **418** can be parallel or substantially parallel with the back frame **424** and the second back frame **1570**. In various embodiments, in the upright state, the first and second side frames **420, 422** can be perpendicular or substantially perpendicular to the front frame **418**, the back frame **424**, and the second back frame **1570**.

In some embodiments, a first outer side **1674** of the grill cart **106** can be defined by a first side portion **1675** of the outer wall **1060** of the base portion **416** and the first side frame **420**. In some embodiments, a second outer side **1676** can be opposite from the first outer side **1674** and can be defined by a second side portion **1677** of the outer wall **1060** and the second side frame **422**. In various embodiments, the first side portion **1675** and the second side portion **1677** can have the same height. In various embodiments, the different coupling locations of the first and second side frames **420, 422** to the base portion **416** can be covered or made non-visible by the outer wall **1060**, such that the first side frame **420** and the second side frame **422** can appear to have the same height and the same coupling location with regards

to the bottom plate **1058**. The difference between first distance **1064** can the second distance **1068** is not visible. The outer wall **1060** can cover or hide the couplings **1062**, **1066**. The outer wall **1060** can extend from a location below all of the couplings between the frames and the base portion **416** to a location above all of the couplings.

Attaching the Burner Box to the Grill Cart

After the panels are locked in the upright state, the burner box **108** can be aligned with the grill cart **106** and the burner box **108** can be coupled to the top of the grill cart **106**. FIG. **17** shows a front view of a burner box **108** being aligned with the grill cart **106** in the upright configuration, such as aligning the projections **530**, **532**, **534**, **536** with the apertures **546**, **548**, **550**, **552**. Once the burner box **108** is aligned with the grill cart **106**, the burner box **108** can be detachably coupled to the grill cart **106**, such as shown in FIG. **18**.

In various embodiments, coupling the burner box **108** to the grill cart **106** in the upright state comprises inserting at least one projection **530**, **532**, **534**, **536** into at least one aperture **546**, **548**, **550**, **552**. In some embodiments, the first projection **530** can be insert into the fifth aperture **546**. In some embodiments, the second projection **532** can be inserted into the sixth aperture **548**. In some embodiments, the third projection **534** can be inserted into the seventh aperture **550**. In some embodiments, the fourth projection **536** can be inserted into the eighth aperture **552**.

In various embodiments, the first aperture **538**, the third aperture **542**, the sixth aperture **548** and the eighth aperture **552** can be located on the same side of the grill cart **106**. Similarly, the second aperture **540**, the fourth aperture **544**, the fifth aperture **546**, and the seventh aperture **550** can be located on the same side of the grill cart **106**.

The apertures **538**, **540**, **542**, **544** can have various shapes or structure to receive a projection. In some embodiments, the apertures **538**, **540**, **542**, **544** can be through-holes, such as shown in FIGS. **9** and **18**. In some embodiments, the apertures **538**, **540**, **542**, **544** can have a covered end, such as to define an enclosed pocket with only one opening, as shown in FIGS. **11-13**. It should be understood that the shape or structure of the apertures **538**, **540**, **542**, **544** is independent of other aspects described herein, such as the order of the frames being transitioned from the folded state to the upright state.

The grill cart **106** can provide a support or a stand for the burner box **108**. The grill cart **106** can include a bottom portion **1720** and a top portion **1722** (shown in FIG. **17**). The burner box **108** can be coupled to the top portion **1722** of the grill cart **106**. In some embodiments, the bottom portion **1720** can include wheels **1724**, or casters, such as to provide easy portability for the grill assembly **102**. In some embodiments, the wheels **1724** can include a brake or lock to prevent the wheels from rotating thereby preventing the cart from moving. In various embodiments, the bottom portion **1720** can include adjustable leveling feet or adjustable leveling wheels to allow a user to adjust the height of the feet or wheels, such as to accommodate for uneven surfaces, which can be common in outdoor applications.

The doors **426** can provide access to the interior of the grill cart **106**. In various embodiments, the interior of the grill cart **106** can house a gas tank. The gas tank can supply the burner box **108** with gas. In some embodiments, the interior of the grill cart **106** can be configured to house or store other related equipment, such as tongs, spatulas, or brushes.

The burner box **108** can be coupled to the grill cart **106** via one or more latch mechanisms **1728**. In various embodiments, a latch mechanism **1728** can be located on or adjacent

to the each of the projections **530**, **532**, **534**, **536** and apertures **538**, **540**, **542**, **544**. In various embodiments, the burner box **108** or projection **530**, **532**, **534**, **536** can include a first portion **1730** of each of the latch mechanisms **1728**, and the grill cart **106** can include a second portion **1732** of each of the latch mechanisms **1728**. FIG. **18** shows the latch mechanisms **1728** coupling the burner box **108** with the grill cart **106**.

In some embodiments, the first portion **1730** can include a hoop, ring, hook, or other device that defines an opening. The example shown in FIG. **18** is a buckle structure that has a portion that rotates to move the buckle structure between open and a closed positions. The example shown in FIG. **18** has two first portions **1730** on each side of the burner box **108** and two second portions **1732** on each side of the grill cart **106**.

The second portion **1732** can include a projection **1738** (FIG. **18**) for mating with the loop of the buckle of the first portion **1730**. The first portion **1730** can be configured to receive the projection from the second portion **1732** into the opening defined by the loop. In various embodiments, the first portion **1730** can transition between an open position and a closed position. In the open position the opening can easily receive the projection. In the closed position, the projection can be secured in the opening. In other embodiments, the second portion **1732** can include a hoop, ring, hook, or other device that defines an opening, and the first portion **1730** can include a projection for mating with the loop of the second portion **1732**. Other options for coupling a burner box to a grill cart are described in co-owned U.S. application Ser. No. 15/937,666 mentioned above.

In various embodiments, a center portion of the first aperture **538** can be located a first distance **1880** away from the back **1888** of the base portion **416**. In various embodiments, a center portion of the third aperture **542** can be located a second distance **1882** away from the front **1890** of the base portion **416**, such as the front of the toe kick panel **114**. In various embodiments, a center portion of the eighth aperture **552** can be located a third distance **1884** away from the back **1888** of the base portion **416**. In various embodiments, a center portion of the sixth aperture **548** can be located a fourth distance **1886** away from the front **1890** of the base portion **416**.

In various embodiments, the first distance **1880** can be equivalent to the third distance **1884**. In various embodiments, the second distance **1882** can be equivalent to the fourth distance **1886**. In various embodiments, the first distance **1880** and the third distance **1884** are not equivalent to the second distance **1882** and the fourth distance **1886**.

In some embodiments, the first distance **1880** and the third distance **1884** are equal and can be about 3 inches, 4 inches, 5 inches, 6 inches, 7 inches, or 8 inches. In some embodiments, the first distance **1880** and the third distance **1884** are equal and can be at least 3 inches and not more than 8 inches, such as 5 inches.

In some embodiments, the second distance **1882** and the fourth distance **1886** are equal can be about 4 inches, 5 inches, 6 inches, 7 inches, 8 inches, or 9 inches. In some embodiments, the second distance **1882** and the third distance **1884** are equal and can be at least 4 inches and not more than 9 inches, such as 6¼ inches.

Now referring to FIG. **6**, in various embodiments, in the folded state, the front face **654** of the burner box **108** can be aligned with the back **1888** of the base portion **416**. In such embodiments, the control elements **655**, locking elements **1572** and other components connected to the burner box **108** and the grill cart **106** can extend past the front face **654** and

17

the back **1888** of the base portion **416**. In the embodiment of FIG. **6**, in the folded state, the front frame **418** also extends past the back **1888** of the base portion **416**. Both the front frame **418** in the folded state and the burner box have a depth dimension larger than the depth of the base portion **416**, and both extend past the base portion **416** in the same direction, thereby minimizing the volume occupied by the grill assembly in the folded state.

Door Construction

FIG. **19** shows a front view of a door **426** being assembled in accordance with various embodiment herein. FIG. **20** shows a front view of an assembled door **426**. In various embodiments, the door **426** can include a panel **1992** and an outer frame **1994**. The outer frame **1994** can have an open end **1996**. The panel **1992** can be inserted into the frame **1994** through the open end **1996** as shown by arrow **1998** in FIG. **19**. A recessed handle **428** can be formed by the panel **1992** along a top edge.

After the panel **1992** is fully inserted into the frame **1994**, a cap portion **2096** can be added to the outer frame **1994**. The cap portion **2096** can enclose the outer frame **1994**, such as to retain the panel **1992** within the outer frame **1994**.

FIG. **21** shows a front view of an alternate door **2126** having a vertical handle **2128** that extends vertically along a side of the door **2126**. The door **2126** is formed by a panel **2192** surrounded by a frame **1994** and a cap portion **2096**. The door **2126** shown in FIG. **21** can be universal, such that the door hinges **2198** can be on the left or the rights, such as by rotating the door **2126** by 180 degrees thereby moving the cap portion **2096** to the bottom of the door **426**.

Methods

FIG. **22** shows a flow chart depicting a method **2200** in accordance with various embodiments herein. In some embodiments, the method **2200** can include transitioning a grill cart from a folded state to an upright state, step **2202**. The method **2200** can further include aligning a burner box with the grill cart in the upright state, step **2204**. The method **2200** can further include coupling the burner box to the grill cart, step **2206**.

FIG. **23** shows a flow chart depicting a method **2300** in accordance with various embodiments herein. In some embodiments, the method **2300** can include uncoupling a burner box from a grill cart in a folded state, step **2302**. The method **2300** can include separating the burner box from the grill cart, step **2304**. In various embodiments, the method **2300** can further include transitioning the grill cart from a folded state to an upright state, step **2306**.

In some embodiments, transitioning the grill cart from a folded state to an upright state can include rotating a front frame from a folded state to an upright state, step **2308**. Transitioning the grill cart from a folded state to an upright state can further include rotating a first side frame and a second side frame from a folded state to an upright state, step **2310**. Transitioning the grill cart from a folded state to an upright state can also include rotating a back frame from a folded state to an upright state, step **2312**. In some embodiments, transitioning the grill cart from a folded state to an upright state include first rotating the front frame, then the two side frames, and finally the back frame. In other embodiments, the back frame can be rotated first, followed by rotating the two side frames, and finally the front frame. In other embodiments, one side frame can be rotated first, followed by the front and back frames, and finally the second side frame. It should be understood that other orders in which the frames are rotated are possible and included herein.

18

The method **2300** can include rotating the grill cart 180 degrees relative to the burner box, step **2314**. Rotating the grill cart 180 degrees relative to the burner box can involve rotating the grill cart, the burner box, or both. Rotating the grill cart 180 degrees relative to the burner box can take place after the burner box is separated from the grill cart and before the burner box is recoupled to the grill cart, such as step **2314** taking place before step **2306**.

The method **2300** can further include aligning the burner box with the grill cart in the upright state, step **2316**. The method **2300** can include coupling the burner box to the grill cart in the upright state **2318**.

It should be noted that, as used in this specification and the appended claims, the singular forms “a,” “an,” and “the” include plural referents unless the content clearly dictates otherwise. It should also be noted that the term “or” is generally employed in its sense including “and/or” unless the content clearly dictates otherwise.

It should also be noted that, as used in this specification and the appended claims, the phrase “configured” describes a system, apparatus, or other structure that is constructed or configured to perform a particular task or adopt a particular configuration. The phrase “configured” can be used interchangeably with other similar phrases such as arranged and configured, constructed and arranged, constructed, manufactured and arranged, and the like.

All publications and patent applications in this specification are indicative of the level of ordinary skill in the art to which this invention pertains. All publications and patent applications are herein incorporated by reference to the same extent as if each individual publication or patent application was specifically and individually indicated by reference.

As used herein, the recitation of numerical ranges by endpoints shall include all numbers subsumed within that range (e.g., 2 to 8 includes 2.1, 2.8, 5.3, 7, etc.).

The headings used herein are provided for consistency with suggestions under 37 CFR 1.77 or otherwise to provide organizational cues. These headings shall not be viewed to limit or characterize the invention(s) set out in any claims that may issue from this disclosure. As an example, although the headings refer to a “Field,” such claims should not be limited by the language chosen under this heading to describe the so-called technical field. Further, a description of a technology in the “Background” is not an admission that technology is prior art to any invention(s) in this disclosure. Neither is the “Summary” to be considered as a characterization of the invention(s) set forth in issued claims.

The embodiments described herein are not intended to be exhaustive or to limit the invention to the precise forms disclosed in the following detailed description. Rather, the embodiments are chosen and described so that others skilled in the art can appreciate and understand the principles and practices. As such, aspects have been described with reference to various specific and preferred embodiments and techniques. However, it should be understood that many variations and modifications may be made while remaining within the spirit and scope herein.

The invention claimed is:

1. A grill comprising:
 - a grill cart configured to be transitioned between an upright state and a folded state; and
 - a burner box configured to be detachably coupled to the grill cart in the upright state;
 wherein the grill cart comprises:

a base comprising a first side, a second side, a third side, a fourth side, a first side portion along the third side, and a second side portion along the fourth side of the base;

a front frame coupled to the first side of the base in the upright state and the folded state;

a back frame coupled to the second side of the base in the upright state and the folded state;

a first side frame coupled to the third side of the base via a first coupling in the upright state and the folded state;

a second side frame coupled to the fourth side of the base via a second coupling in the upright state and the folded state;

wherein the first coupling between the first side frame and the base is located in a first plane that is substantially parallel with a plane defined by a bottom plate of the base, and the second coupling between the second side frame and the bottom plate of the base is located in a second plane that is substantially parallel with the plane defined by the bottom plate,

wherein the first plane is located a first distance away from the plane defined by the bottom plate and the second plane is located a second distance away from the plane defined by the bottom plate, wherein the first distance is not equivalent to the second distance;

wherein the first side portion of the base and the second side portion of the base extend from the bottom plate past the first plane and the second plane;

wherein, in the upright state, a first outer side of the grill is defined by the first side portion of the base and a portion of the first side frame and a second outer side of the grill is defined by the second side portion of the base and a portion of the second side frame, such that the first coupling and the second coupling are not visible from an exterior of the grill cart.

2. The grill of claim 1, wherein in the upright state, the front frame, the back frame, the first side frame, and the second side frame are substantially perpendicular to the base.

3. The grill of claim 1, wherein in the folded state, the first side frame overlaps the second side frame.

4. The grill of claim 3, wherein in the folded state, the front frame overlaps the back frame.

5. The grill of claim 1, wherein in the folded state the front frame, the back frame, the first side frame, and the second side frame are substantially parallel with the base, and at least one of the first side frame and the second side frame are disposed between the front frame and the back frame.

6. The grill of claim 1, wherein the grill in the folded state has a volume of no more than 42,000 inches³.

7. A grill comprising:

a grill cart configured to be transitioned between an upright state and a folded state; and

a burner box configured to be detachably coupled to the grill cart in the upright state;

wherein the grill cart comprises:

a base comprising a first side, a second side, a third side, a fourth side, a first side portion along the third side, and a second side portion along the fourth side of the base;

a front frame coupled to the first side of the base in the upright state and the folded state;

a back frame coupled to the second side of the base in the upright state and the folded state;

a first side frame coupled to the third side of the base via a first coupling in the upright state and the folded state;

a second side frame coupled to the fourth side of the base via a second coupling in the upright state and the folded state;

wherein the first coupling between the first side frame and the base is located in a first plane that is substantially parallel with a plane defined by a bottom plate of the base, and the second coupling between the second side frame and the bottom plate of the base is located in a second plane that is substantially parallel with the plane defined by the bottom plate,

wherein the first plane is located a first distance away from the plane defined by the bottom plate and the second plane is located a second distance away from the plane defined by the bottom plate, wherein the first distance is not equivalent to the second distance;

wherein the first side portion of the base and the second side portion of the base extend from the bottom plate past the first plane and the second plane;

wherein in the folded state the front frame, the back frame, the first side frame, and the second side frame are substantially parallel with the base, and at least one of the first side frame and the second side frame are disposed between the front frame and the back frame.

8. The grill of claim 7, wherein in the upright state, the front frame, the back frame, the first side frame, and the second side frame are substantially perpendicular to the base.

9. The grill of claim 7, wherein in the folded state, the first side frame overlaps the second side frame.

10. The grill of claim 9, wherein in the folded state, the front frame overlaps the back frame.

11. The grill of claim 7, wherein the grill in the folded state has a volume of no more than 42,000 inches³.

* * * * *