



(22) **Date de dépôt/Filing Date:** 2012/02/29

(41) **Mise à la disp. pub./Open to Public Insp.:** 2012/10/01

(45) **Date de délivrance/Issue Date:** 2016/09/27

(30) **Priorité/Priority:** 2011/04/01 (EP11160819)

(51) **Cl.Int./Int.Cl. B65H 19/26** (2006.01),
B65H 35/00 (2006.01)

(72) **Inventeurs/Inventors:**
TIITTA, JARI, FI;
KOJO, TEPPU, FI;
SIMPANEN, PENTTI, FI;
TUOMINEN, AKI, FI

(73) **Propriétaire/Owner:**
METSO PAPER, INC., FI

(74) **Agent:** GOWLING WLG (CANADA) LLP

(54) **Titre : METHODE D'ENROULEMENT DE TOILES EN FIBRE ET DISPOSITIF D'ENROULEMENT DESDITES TOILES EN FIBRE**

(54) **Title: METHOD IN TURN-UP OF REELING OF FIBER WEBS AND A TURN-UP DEVICE FOR A REEL-UP OF FIBER WEBS**

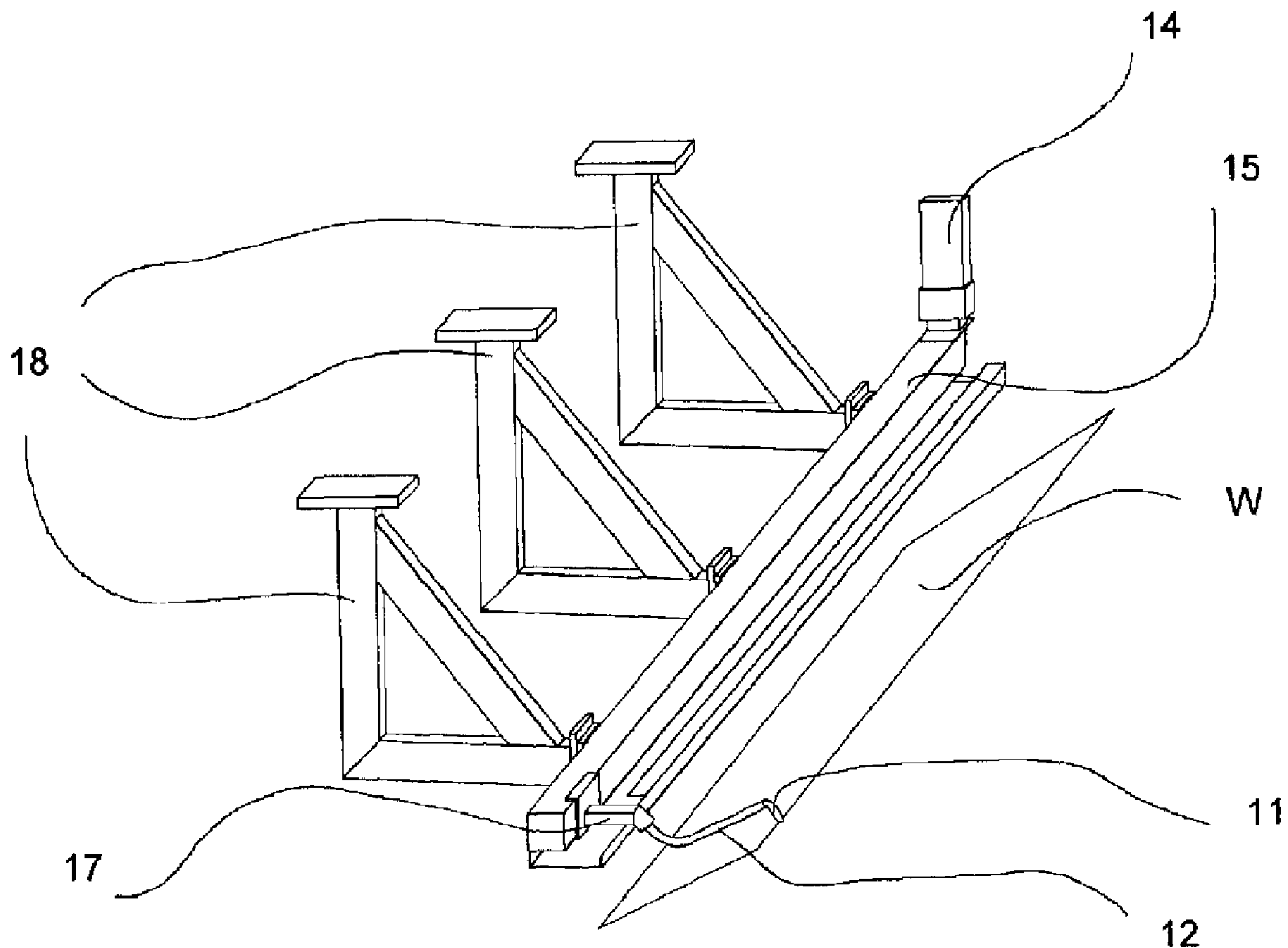

(57) **Abrégé/Abstract:**

The invention relates to a method for turn-up of reeling of fiber webs, in which method the web is reeled by a reeling drum of a reel-up onto a parent roll, by which when the parent roll has reached the desired diameter size, reeling is changed from the parent roll of

(57) Abrégé(suite)/Abstract(continued):

desired size onto a new parent roll, in which method, the web is cut by jet cutting means and beginning part of the cut web is directed onto a reeling shaft a new parent roll. In the method the cutting path of the jet cutting means comprises a main cutting path and at least one edge area cutting path and that length of the main cutting path comprises at least 60 % of the whole cutting path length from one edge of the web to the other edge of the web. The invention also relates to a turn-up device for a reel-up of fiber webs, which device comprises one cutting module and at least one nozzle for jet cutting, which is attached movably and turnably to the module by a cutting arm.

Abstract

The invention relates to a method for turn-up of reeling of fiber webs, in which method the web is reeled by a reeling drum of a reel-up onto a parent roll, by which when the parent roll has reached the desired diameter size, reeling is changed from the parent roll of desired size onto a new parent roll, in which method, the web is cut by jet cutting means and beginning part of the cut web is directed onto a reeling shaft a new parent roll. In the method the cutting path of the jet cutting means comprises a main cutting path and at least one edge area cutting path and that length of the main cutting path comprises at least 60 % of the whole cutting path length from one edge of the web to the other edge of the web. The invention also relates to a turn-up device for a reel-up of fiber webs, which device comprises one cutting module and at least one nozzle for jet cutting, which is attached movably and turnably to the module by a cutting arm.

Method in turn-up of reeling of fiber webs and a turn-up device for a reel-up of fiber webs

In general present invention relates to reeling of fiber webs in a fiber web machine. More especially the present invention relates to a method in turn-up of reeling
5 of fiber webs and to a turn-up device for a reel-up of fiber webs.

As known from the prior art in fiber web producing processes typically comprise an assembly formed by a number of apparatuses arranged consecutively in the process line. A typical production and treatment line comprises a head box, a wire
10 section and a press section as well as a subsequent drying section and a reel-up. The production and treatment line can further comprise finishing devices, for example a calender and/ or a coater. The production and treatment line also comprises typically at least one slit-winder for forming customer rolls as well as a roll packaging apparatus.

15 The reel-up is a device which reels a material produced as a continuous fibrous web into the reel form as a machine reel. In the production process of the fibre web, reeling-up is usually the first subprocess in which continuous production is interrupted to continue in sequences. The machine reel is formed around the reel
20 spool operating as the reeling core i.e. the fibrous web being on one machine reel has a start and an end. The trend in the field is a continuous increase in the size of machine reels, which causes an on-going development requirement for reel-ups. The dimensioning of the reel spool specifies the maximum size of the machine reel in practice. However, as we are concerned with a dynamic environment and the fi-
25 bre web is reelable material sensitive to various faults, the task performed by the reel-up as the maintainer of the efficiency of the paper or board machine is very considerable. A reason behind the continuous increase in the size of machine reels is the desire to obtain fewer starts and ends in the production of the fibrous web, which impede or disturb the production and decrease the efficiency.

30 In the reel-up of a continuously operating fiber web machine or a finishing part, for example a coating part, or equivalent, when the parent (machine) roll to be reeled becomes full or reaches the desired size, the fiber web is changed from the full roll onto an reeling shaft for beginning of reeling of a new parent roll typically at full
35 running speed of the machine. In such case from the cutting-off of the fiber web and from its change onto the new reeling shaft for beginning of reeling or the new

parent roll reliability of operation is required in order that the operation should not have to be interrupted.

5 It is well-known from prior art to use a water jet to cut the fibrous web by a special device. The device according to US patent 6,135,000 comprises at least one, preferably two carriages, which are moved on a guide bar and which comprise nozzles that move along with the carriage for shooting the water jet(s) to cut the moving fibrous web. In addition to the moving nozzles, the device also comprises moving hose wheels, the purpose of which is to keep the high-pressure hoses, 10 which lead to the nozzles, directly conveyed during the fast movement of the carriage. The longitudinal feed of the hose is synchronously connected to the movement of the carriage and the feed can be controlled both during the cutting and the return movement.

15 In US 5,360,179 patent publication a method and a device for reeling a web is described wherein the web is reeled by a reeling drum onto a parent roll, whereby when the parent roll has reached the desired diameter size, new reeling is started from the parent roll of desired size onto a new parent roll. After the parent roll has reached the desired diameter size, a tip part is cut into the web by means of a water jet or water jets and the tip part is blown into contact with a reeling shaft of the new parent roll, whereupon the web is cut off by means of the water jet or water jets. In this prior art arrangement the publication describes the means with two water jets used in the cutting but only reference of cutting with one water jet is disclosed but not actual means are taught. The cutting path with one water jet shown 25 in figure 2 C is in many cases impossible or at least very difficult in practice since there is no room for the nozzle movement all the way from one edge to another edge due to different components of the reel-up located at the sides. Thus the areas near the edge cannot be cut by the water jets and the web tears uncontrollably and increases the risk of web break or other disturbances. The arrangement with two nozzles as shown in figure 1 and the cutting paths shown in figures 2A – 2B require two sets equipment including for example two slides, two motors and two cutting modules one for each nozzle and cutting path. In these prior art arrangements the linear module has a restricted length due to other components of the reel-up for example due to the space needed for reel spool storage lowering 35 arms and thus the cut does not reach the edges of the web without complicated special arrangements. One disadvantage of these prior art arrangements is that the cutting pressure for the nozzle / nozzles is risen to the right cutting level only after the nozzle / nozzles (has moved) has / have been on the web already some

time and during the waiting time for right pressure level causes broke. This is critical especially when cutting thicker fiber webs f. ex. board since there the waiting time is longer since it is critical that the cutting pressure is correct when the cutting is begun otherwise the web is not cut or it tears uncontrollably.

5 In FI patent 120445 is described an arrangement for a water jet turn-up device in which the beam for a nozzle and/or nozzles is/are movable and/or turnable from cutting position to maintenance position for changing the nozzles of the water jet turn-up device and for other maintenance actions to the device.

10 If a nozzle of a water jet turn-up device is not functioning it has to be changed and the web has to be cut manually and the reel-up has to be stopped at least partially for the change of the nozzles. As this causes a break in production it need to be done as fast as possible to minimize the break time.

15 Another non-mandatory object of the present invention is to create a new improved method in turn-up of reeling of fiber webs and a turn-up device for a reel-up of fiber webs in which possible disadvantages and problems of known methods and devices are eliminated or at least minimized.

One object of the present invention is to solve at least part of the disadvantages and problems relating to methods and devices according to prior art.

20 To achieve the objects mentioned above and later, there is provided a method according to the invention, in which the web is reeled by a reeling drum of a reel-up onto a parent roll, by which when the parent roll has reached the desired diameter size, reeling is changed from the parent roll of desired size onto a new parent roll, wherein the web is cut by jet cutting means and beginning part of the cut web is directed onto a reeling shaft of a new parent roll, wherein the cutting path of the jet cutting means comprises a linear main cutting path and at least one edge
25 area cutting path and that length of the main cutting path comprises at least 60 % of the whole cutting path length from one edge of the web to the other edge of the web, wherein the jet cutting means comprises a water jet device, and the web is cut by the water jet device with one nozzle and the edge cutting is provided by turning a cutting arm of the nozzle around a pivot point to accomplish the at least one edge area cutting path deviating from the linear main cutting
30 path.

In accordance with another aspect of the invention, there is provided a turn-up device for a reel-up of fiber webs, which includes: one cutting module, and at least one nozzle for jet cutting,

3a

which is attached movably and turnably to the cutting module by a cutting arm, wherein the cutting module is a linear module. The device according to the invention comprises comprising one cutting module and at least one nozzle for jet cutting.

5 In this description and in the claims by jet cutting are meant such cutting means that accomplish the cutting of the fiber web by jet, in particular water jet cutting. It is to be understood that jet cutting also cover applications of laser cutting and cutting by liquid jet with other liquid than water and cutting by jet of a gaseous substance, and combinations of those.

In the method according to the invention the cutting path comprises a main cutting path and an edge area cutting path. In the method at least 60 % and advantageously at least 75 % of the cutting path length is covered by the main cutting path. Advantageously the main cutting path is cut by one nozzle with turning the nozzle around a pivot point such that the edge area cutting path deviates from the main cutting path. The edge area cutting is advantageously in the end of the cutting path.

In this description and in the claims the by the edge area is meant the area in transverse direction of the web near an edge or the web. The length of the edge area cut i.e. the cut in area near the edge is typically less than 25 % of the transverse length of the web i.e. the width of the web.

According to an advantageous embodiment of the invention the device comprises one nozzle and the edge cutting is done by turning the nozzle to accomplish a cutting movement deviating from the substantially linear main cutting movement. The device comprises according to a preferred feature a pivot point such as a turning joint and mechanical lever mechanism by which when the nozzle reaches the unlocking point for the turning joint providing for the turning of the cutting arm.

According to an other embodiment of the invention in which the turn up device has two nozzles the the main cutting path is cut by one water jet from one nozzle and the edge cutting path is cut by another water jet from another nozzle .

According to further advantageous features of the invention the device has one full width linear module that provides for full width cutting of the web from one edge to the other edge. One or two nozzles are attached by cutting arm /cutting arms to a slide attached transferrable to the module. The cutting arm / cutting arms provide for transferring the nozzle / nozzles outside the web edge. If two nozzles are used the cutting arms are consisted of a T-shaped arm construction such that only one water channel from water source is needed. The cutting arms in two nozzle construction are advantageously of different length such that in cutting situation the nozzle the first is closer to the module than the one coming behind thus making the web slice in between the cuts narrowing.

According to another feature in the embodiment of two cutting nozzles the device is advantageously provided with control system for controlling the cutting of each nozzle and for arranging a delay in cutting with the second nozzle for achieving crossing cutting paths in order to minimize the amount of broke.

According to another advantageous feature the device has turning means for change of nozzles or for maintenance for nozzle. By these turning means the nozzle is turned to the side of the reel-up into position where it is easily reachable outside of woving fiber web area for maintenance. In the embodiment of two nozzles
5 advantageously each nozzle is turned at different sides of the reel up and the nozzle change can be done during production which leads to better efficiency.

The present invention provides for the possibility to raise the pressure level to correct cutting pressure outside the web area and thus the cutting is possible to start right at the edge and this eliminates or at least minimizes the broke amount.

10 In the following the invention is discussed in more detail by reference to figures of accompanying drawings.

Figure 1 shows schematically one example of one embodiment of a device according to the invention.

Figure 2 shows schematically an enlarged partial image of figure 1.

15 Figure 3 shows schematically one example arrangement for mounting an example of one embodiment of a device according to the invention.

Figure 4 shows schematically an example for changing a nozzle of a device according to an embodiment of the invention.

20 Figure 5 shows schematically some possibilities for cutting paths of one embodiment of the invention.

Figure 6 shows schematically one example of one embodiment of a device according to the invention.

Figure 7 shows schematically some possibilities for cutting paths of one embodiment of the invention.

25 Figure 8 shows schematically some possibilities for cutting paths of one embodiment of the invention.

In the following description same reference signs designate for similar components unless otherwise mentioned and it should be understood that the examples are susceptible of modification in order to adapt to different usages and conditions
30 within the frames of the invention.

In the example of figures 1 - 2 the turn-up device for a reel-up of a fiber web machine comprises a linear module 15 with motor 14. One water jet nozzle 11 is attached to cutting arm 12. Other end of the cutting arm 12 is movably attached to the slide surface of the linear module 15 and has a turning joint 17. In this example
5 stoppers 13 attached at each end of the linear module spaced from the end limit the main cutting movement and give the mechanical impulse for the edge area movement and turning of the cutting arm 12 with the nozzle 11 around the turning joint 17.

As shown in the example of figure 3 device 10 is attached to frame of a reel-up by
10 frame parts 18 that support the device 10 and are attached to the linear module 15. Web W to be cut is located below the device 10 and the cutting movement of the cutting arm 12 with the nozzle 11 is arranged to cover the whole width of the web by combination of the main cutting movement and the edge cutting movement / movements.

15 The device 10 in the embodiment of one nozzle comprises one nozzle 11 and the edge cutting 21A, 21B is done by turning the cutting arm 12 to accomplish a cutting movement deviating from the substantially linear main cutting movement 20. The device 20 comprises according to a preferred feature a turning joint 17 and mechanical lever mechanism i.e. stopper 13 by which when the cutting arm 12
20 reaches at stopper 13 the unlocking for the turning joint 17 is provided by a lever mechanism (not shown) providing for the turning of the cutting arm 12.

In figure 4 is shown one example for the nozzle change and maintenance position of the cutting arm 12. In the figure the nozzle 11 and the cutting arm 12 are in a cutting position but the cutting arm 12 with the nozzle 11 is turnable around the
25 turning joint 17 to the change and maintenance position on the side of the device as shown by movement path M. In the embodiment of two nozzles advantageously each nozzle is turned at different sides of the reel up.

As shown in figure 5 the cutting path of the water jet for cutting the web comprises the main cutting path 20 formed by the main cutting movement of the cutting arm
30 12 and the nozzle 11 in the embodiment of the invention in which one nozzle is used. The main cutting path 20 covers at least 60 %, advantageously at least 75 % of the width of the web. The edge cutting path 21A; 21B are formed by turning the cutting arm 12 with the nozzle 11 around the turning joint. Several different forms for the edge cutting path 21A; 21B are possible, depending on the speed of
35 the web, the speed of the turning movement, the set up values for turning etc.

In figure 6 is a very schematic presentation of one embodiment of the invention in which two nozzles 11A; 11B are used instead of one nozzle 11 and each nozzle has its own cutting arm 12A, 12B that advantageously unite to a T-form and thus only one attachment to the linear module 15 is needed. In this embodiment the
5 main cutting path is done by one nozzle and the edge cutting path is done by the other nozzle for example as shown in examples of figures 7 and 8.

In figures 7 and 8 are schematic examples of the cutting movements. In example of figure 7 the web is cut by using the both nozzles 11A and 11B and a slice web WB is formed in-between the cuts. In example of figure 8 each nozzle 11A; 11B has
10 its own control valve and thus one of the cuts can be limited to the edge area only.

As shown in the previous figures the water jet turn up device 10 comprises one cutting module 15, advantageously a linear module and at least one nozzle 11; 11A, 11B. In the method the cutting path comprises a main cutting movement 20 and an edge area cutting movement 21A; 21B. In the method over 50% advantageously at least 60 % and more advantageously over 75 % of the cutting path is
15 cut by one nozzle 11; 11A; 11B and the edge area cutting is advantageously in the end of the cutting path. According to further advantageous features the device 10 has one full width linear module 15 that provides for full width cutting of the web W from one edge to the other edge. One 11 or two 11A, 11B nozzles are attached by
20 cutting arm 12 /cutting arms 12A, 12B to a slide attached transferrable to the module. The cutting arm / cutting arms provide for transferring the nozzle / nozzles outside the web edge. If two nozzles are used the cutting arms are consisted of a T-shaped arm construction such that only one water channel from water source is needed. The cutting arms in two nozzle construction are advantageously of different
25 length such that in cutting situation the nozzle the first is closer to the module than the one coming behind thus making the web slice in between the cuts narrowing.

In the embodiment of two cutting nozzles the device is advantageously provided with control system for controlling the cutting of each nozzle and for arranging a
30 delay in cutting with the second nozzle for achieving crossing cutting paths in order to minimize the amount of broke, as shown in figure 8.

Above some preferred embodiments and examples of the invention have been described but many modifications are possible to those presented.

What is claimed is:

1. Method in turn-up of reeling of fiber webs, wherein the web is reeled by a reeling drum of a reel-up onto a parent roll, by which when the parent roll has reached the desired diameter size, reeling is changed from the parent roll of desired size onto a new parent roll, wherein the web is cut by jet cutting means and beginning part of the cut web is directed onto a reeling shaft of a new parent roll, wherein the cutting path of the jet cutting means comprises a linear main cutting path and at least one edge area cutting path and that length of the main cutting path comprises at least 60 % of the whole cutting path length from one edge of the web (W) to the other edge of the web (W),

wherein the jet cutting means comprises a water jet device, and the web (W) is cut by the water jet device with one nozzle (11) and the edge cutting is provided by turning a cutting arm (12) of the nozzle (11) around a pivot point (17) to accomplish the at least one edge area cutting path (21A; 21B) deviating from the linear main cutting path (20).

2. Method according to claim 1, wherein at least 75 % of the cutting path is covered by the main cutting path.

3. Method according to claim 1, wherein the edge area cutting is in the end of the cutting path.

4. Method according to claim 1, wherein the main cutting path is cut by one water jet from one nozzle (11 A) and the edge cutting path is cut by another water jet from another nozzle (11B).

5. Turn-up device for a reel-up of fiber webs, comprising:
one cutting module (15), and
at least one nozzle (11) for jet cutting, which is attached movably and turnably to the cutting module (15) by a cutting arm (12),
wherein the cutting module is a linear module (15).
6. Device according to claim 5, further comprising:
a pivot point (17) and mechanical lever mechanism (13) by which the nozzle (11) is unlocked for the turning of the cutting arm around the pivot point (17).
7. Device according to claim 5, wherein two nozzles (11A, 11B) are attached by cutting arms (12A, 12B) to a slide attached transferrable to the module (15).
8. Device according to claim 7, wherein the cutting arms (12A, 12B) are consisted of a T-shaped arm construction such that only one channel from cutting jet source is needed.
9. Device according to claim 7, wherein the cutting arms (12A, 12B) are of different length such that in cutting situation the nozzle the first is closer to the module than the one coming behind thus making the web slice (WB) in between the cuts narrowing.
10. Device according to claim 5, wherein the nozzles (11; 11A, 11B) is provided with control system for controlling the cutting of each nozzle.

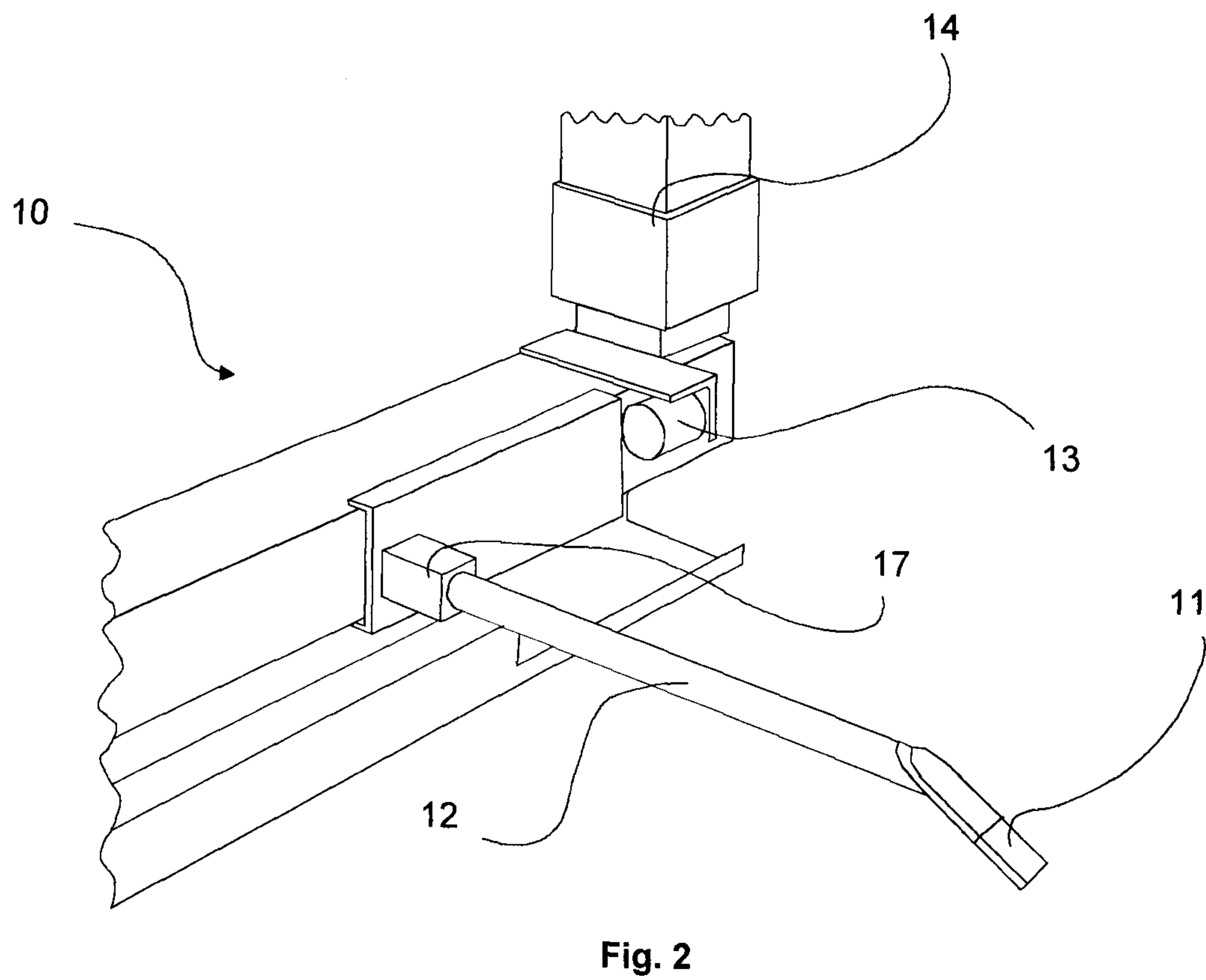
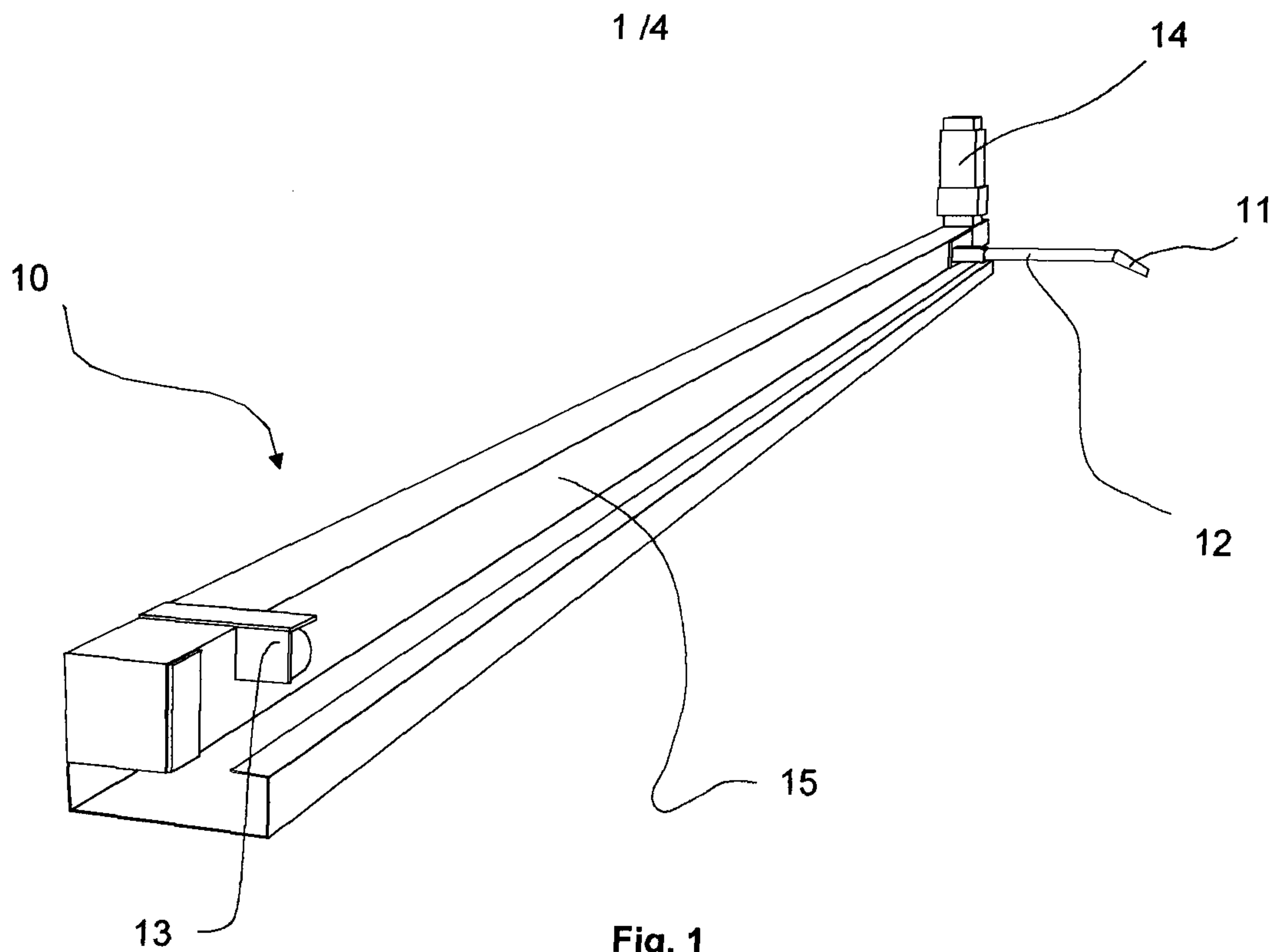

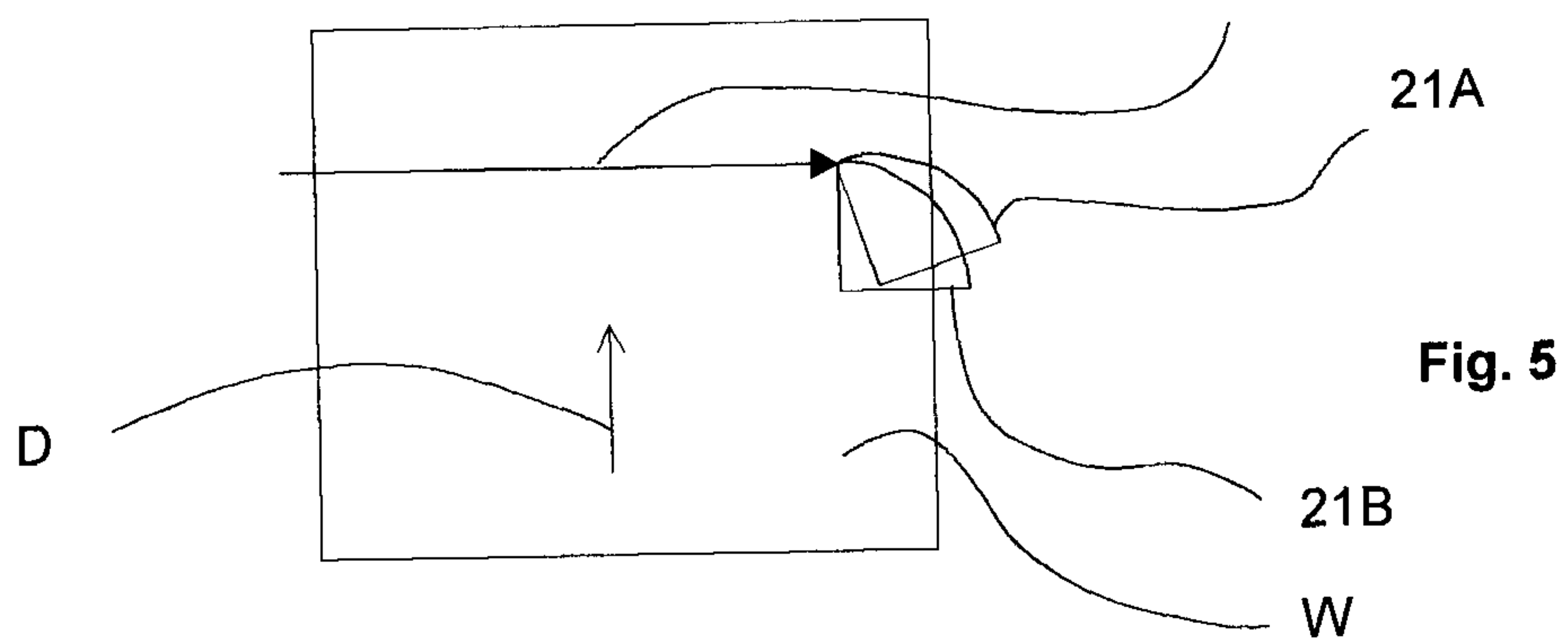
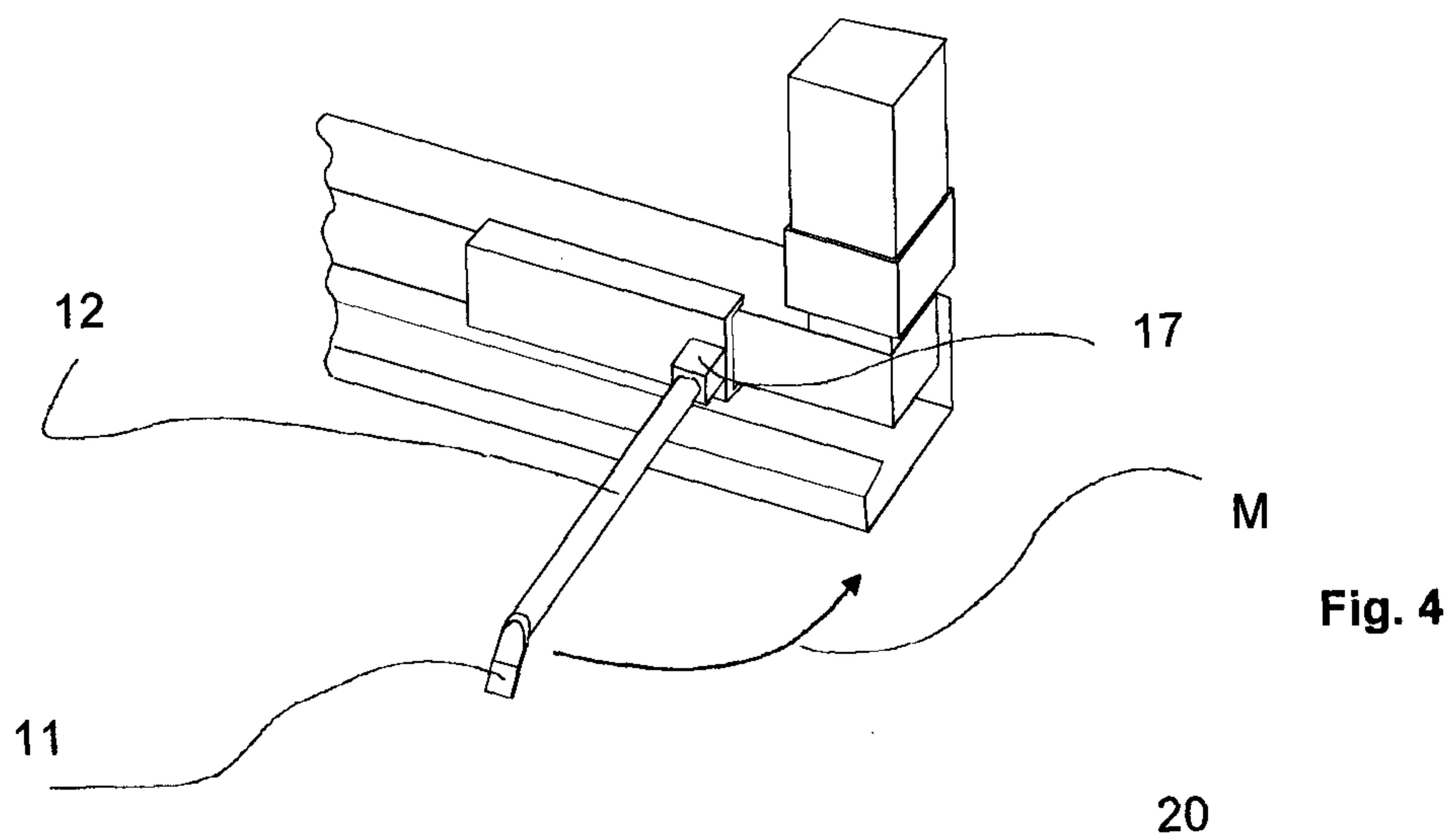
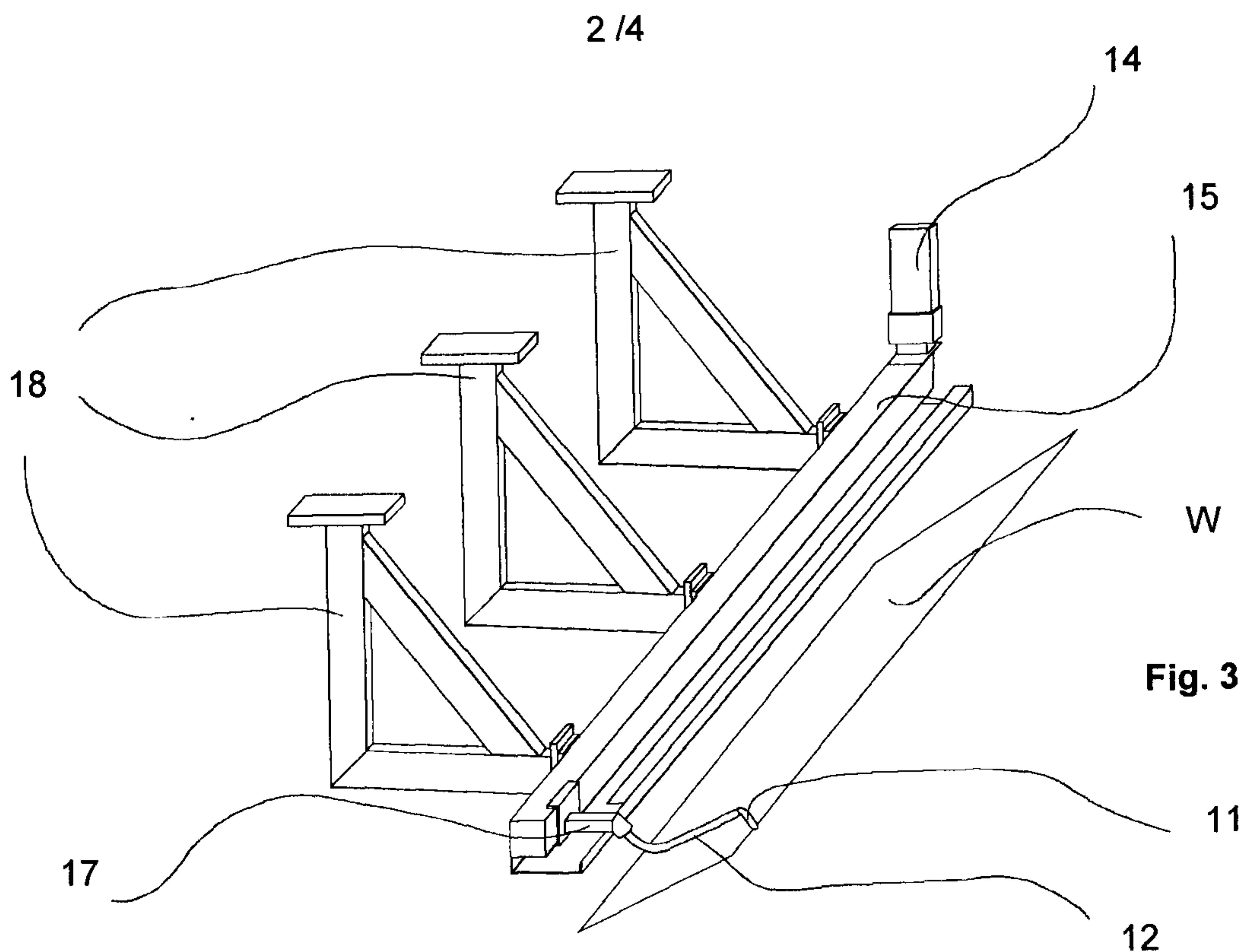

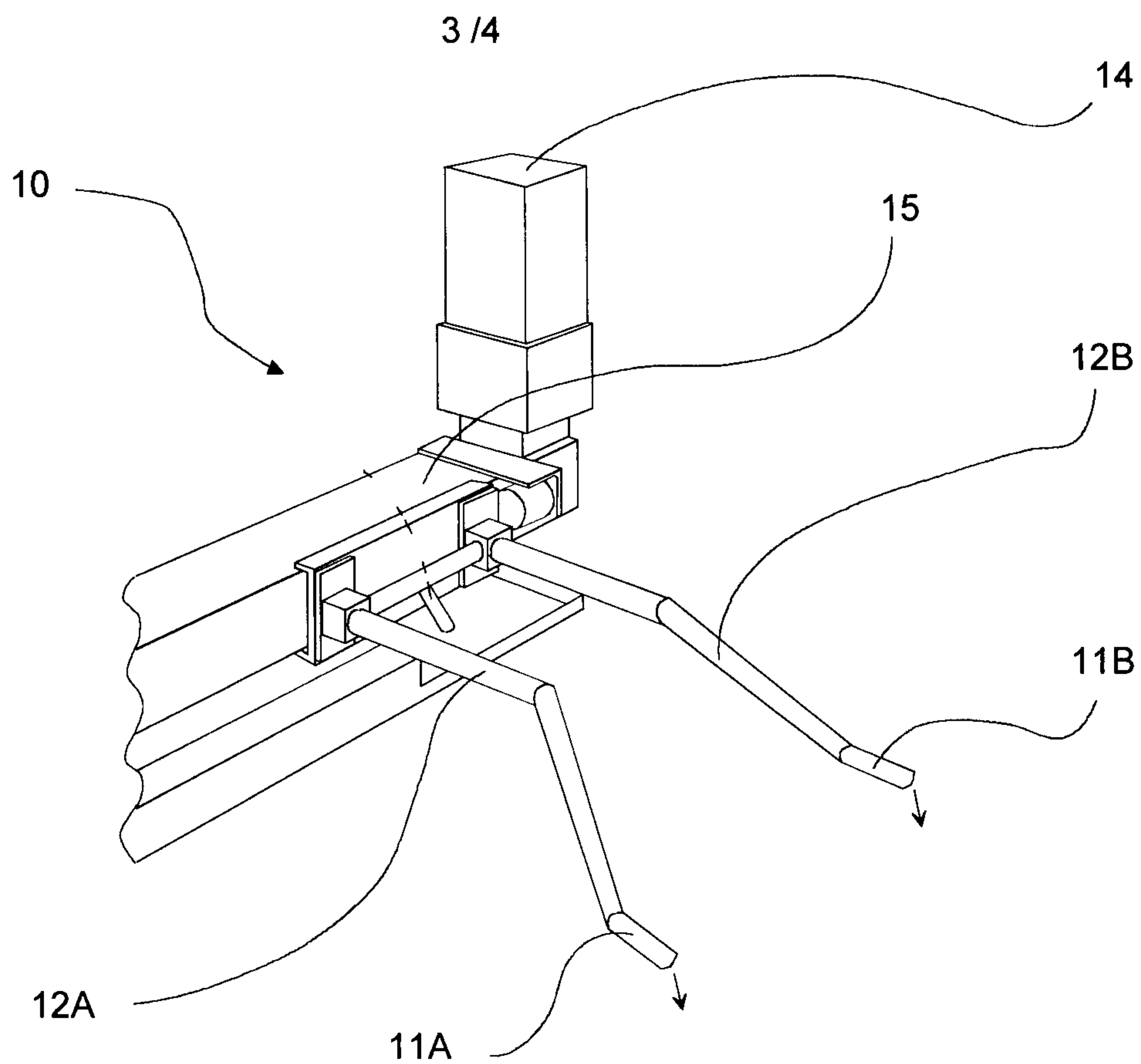

Fig. 6

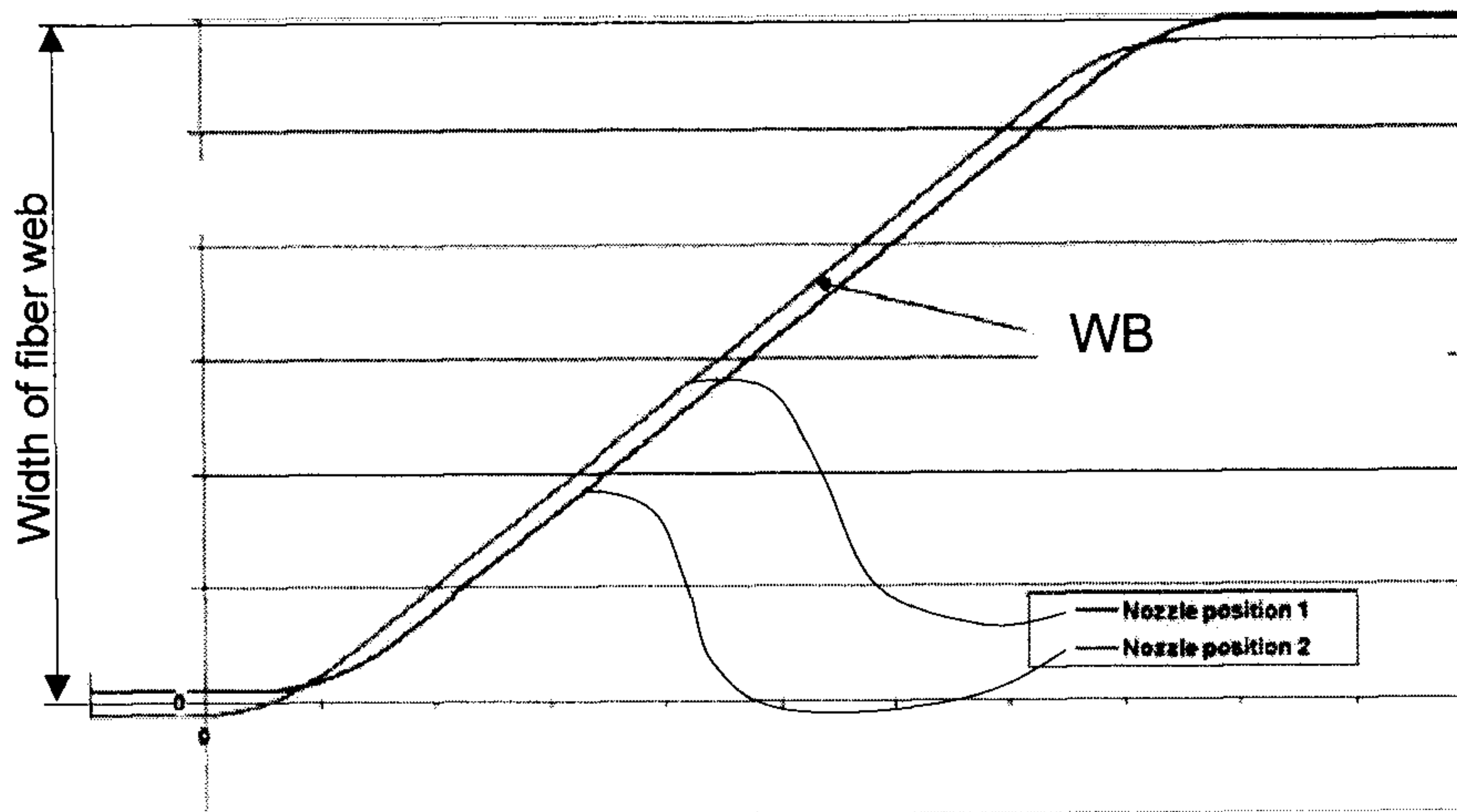

Fig. 7

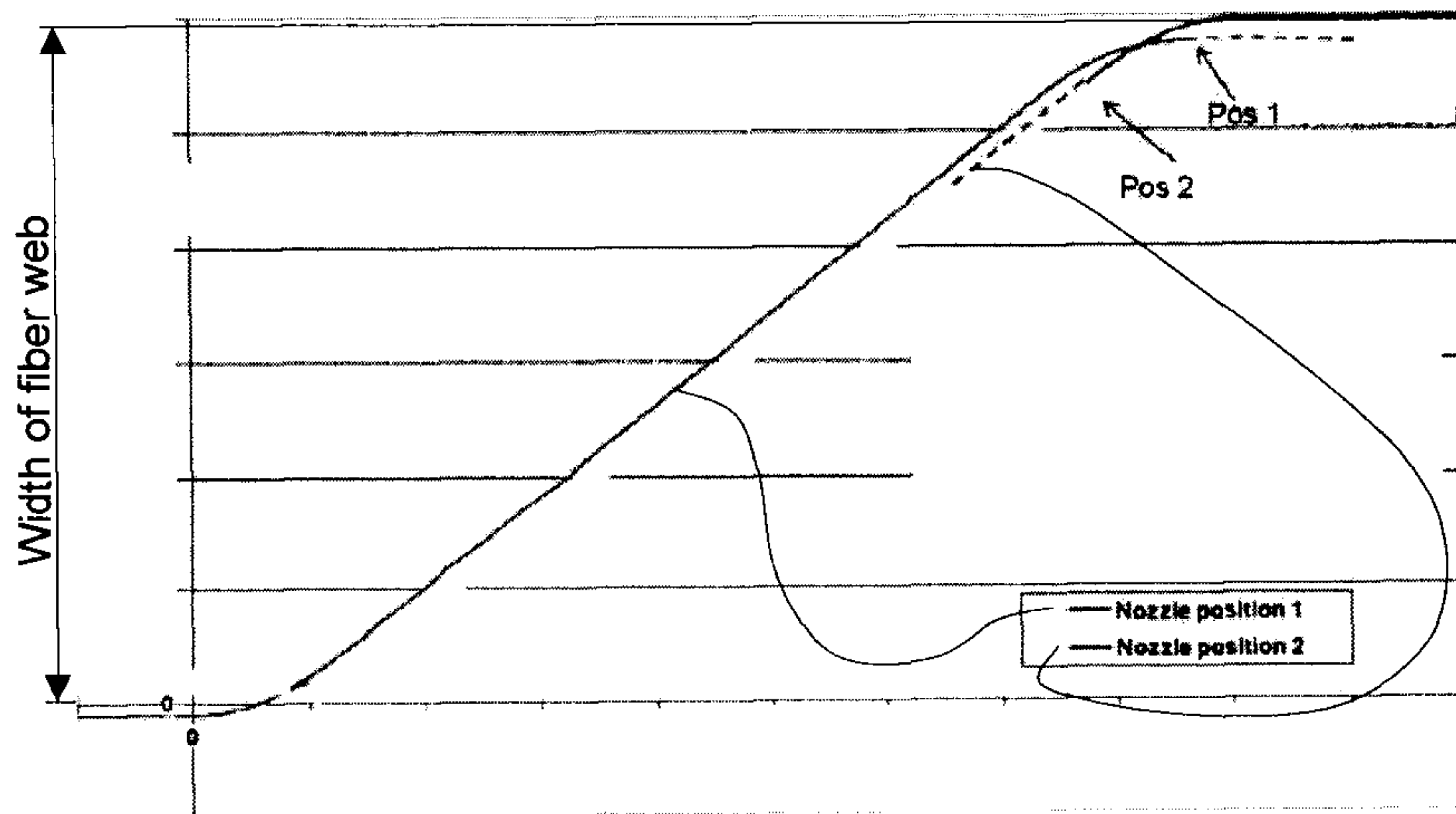

Fig. 8

