



- (51) **International Patent Classification:**
A61B 17/3207 (2006.01) *A61M 25/01* (2006.01)
A61B 1/04 (2006.01)
- (21) **International Application Number:** PCT/US2013/031901
- (22) **International Filing Date:** 15 March 2013 (15.03.2013)
- (25) **Filing Language:** English
- (26) **Publication Language:** English
- (30) **Priority Data:** 61/646,843 14 May 2012 (14.05.2012) US
- (71) **Applicant:** AVINGER, INC. [US/US]; 400 Chesapeake Drive, Redwood City, CA 94063 (US).
- (72) **Inventors:** GUPTA, Priyanshu; 400 Chesapeake Drive, Redwood City, CA 94063 (US). ZUNG, Michael; 400 Chesapeake Drive, Redwood City, CA 94063 (US). MCNALL, Charles, W.; 400 Chesapeake Drive, Redwood City, CA 94063 (US). SPINELLI, Nicholas, J.; 400 Chesapeake Drive, Redwood City, CA 94063 (US). KARWA, Anupama; 400 Chesapeake Drive, Redwood City, CA 94063 (US). NGUYEN, Noel, Nhu-ngoc; 400 Chesapeake Drive, Redwood City, CA 94063 (US). PATEL, Himanshu, N.; 400 Chesapeake Drive, Redwood City, CA 94063 (US). VAN, Christina; 400 Chesapeake Drive, Redwood City, CA 94063 (US). STALKER, Kent, C.b.; 400 Chesapeake Drive, Redwood City, CA 94063 (US).
- (74) **Agents:** KELLEHER, Kathleen, R. et al.; Shay Glenn LLP, 2755 Campus Drive, Suite 210, San Mateo, CA 94403 (US).
- (81) **Designated States** (*unless otherwise indicated, for every kind of national protection available*): AE, AG, AL, AM, AO, AT, AU, AZ, BA, BB, BG, BH, BN, BR, BW, BY, BZ, CA, CH, CL, CN, CO, CR, CU, CZ, DE, DK, DM, DO, DZ, EC, EE, EG, ES, FI, GB, GD, GE, GH, GM, GT, HN, HR, HU, ID, IL, IN, IS, JP, KE, KG, KM, KN, KP, KR, KZ, LA, LC, LK, LR, LS, LT, LU, LY, MA, MD, ME, MG, MK, MN, MW, MX, MY, MZ, NA, NG, NI, NO, NZ, OM, PA, PE, PG, PH, PL, PT, QA, RO, RS, RU, RW, SC, SD, SE, SG, SK, SL, SM, ST, SV, SY, TH, TJ, TM, TN, TR, TT, TZ, UA, UG, US, UZ, VC, VN, ZA, ZM, ZW.
- (84) **Designated States** (*unless otherwise indicated, for every kind of regional protection available*): ARIPO (BW, GH, GM, KE, LR, LS, MW, MZ, NA, RW, SD, SL, SZ, TZ, UG, ZM, ZW), Eurasian (AM, AZ, BY, KG, KZ, RU, TJ, TM), European (AL, AT, BE, BG, CH, CY, CZ, DE, DK, EE, ES, FI, FR, GB, GR, HR, HU, IE, IS, IT, LT, LU, LV, MC, MK, MT, NL, NO, PL, PT, RO, RS, SE, SI, SK, SM, TR), OAPI (BF, BJ, CF, CG, CI, CM, GA, GN, GQ, GW, ML, MR, NE, SN, TD, TG).
- Published:**
— *with international search report (Art. 21(3))*



(54) **Title:** ATHERECTOMY CATHETERS WITH IMAGING

(57) **Abstract:** An atherectomy catheter includes an elongate flexible catheter body, an elongate deflectable distal tip coupled to the catheter body at a hinge point, a rotatable cutter near the distal end of the catheter body, and a drive shaft extending within the catheter body and configured to rotate the cutter. The atherectomy catheter further includes an optical fiber extending through the drive shaft substantially on-axis with the catheter body and attached to the cutter. The optical fiber is configured to rotate with the drive shaft. The atherectomy catheter further includes a wedge configured to deflect the distal tip away from the catheter body at the hinge point upon axial movement of the drive shaft.

ATHERECTOMY CATHETERS WITH IMAGING**CROSS REFERENCE TO RELATED APPLICATIONS**

[0001] This application claims priority to U.S. Provisional Application No. 61/646,843, titled
5 “ATHERECTOMY CATHETERS WITH IMAGING,” filed on May 14, 2012, which is
incorporated by reference herein.

[0002] This application may be related to U.S. Patent Application No. 13/175,232, titled
“ATHERECTOMY CATHETERS WITH LONGITUDINALLY DISPLACEABLE DRIVE
SHAFTS,” filed 7/1/2011, Publication No. US-2012-0046679-A1, which is incorporated by
10 reference herein in its entirety.

INCORPORATION BY REFERENCE

[0003] All publications and patent applications mentioned in this specification are herein
incorporated by reference in their entireties to the same extent as if each individual publication or
15 patent application was specifically and individually indicated to be incorporated by reference.

BACKGROUND

[0004] A significant body of scientific and clinical evidence supports atherectomy as a viable
primary or adjunctive therapy prior to stenting for the treatment of occlusive arterial disease.

20 Atherectomy offers a simple mechanical advantage over alternative therapies. By removing the
majority of plaque mass (debulking), it creates a larger initial lumen and dramatically increases
the compliance of the arterial wall. As a result, stent deployment is greatly enhanced.

[0005] Additionally, atherectomy provides several advantages related to the arterial healing
response. When circumferential radial forces are applied to the vasculature, as in the case of
25 angioplasty or stenting, the plaque mass is displaced, forcing the vessel wall to stretch
dramatically. This stretch injury is a known stimulus for the cellular in-growth that leads to
restenosis. By using atherectomy to remove the disease with minimal force applied to the vessel,
large gains in lumen size can be created with decreased vessel wall injury and limited elastic
recoiling. These effects have been shown to generate better acute results and lower restenosis
30 rates.

[0006] Despite its advantages, atherectomy is not commonly performed due to the cost,
complexity and limited applicability of available atherectomy devices. Many designs are unable
to treat the wide range of disease states present in long complex lesions; luminal gain is often
limited by the requirement of the physician to introduce multiple devices with increased crossing

profiles; tissue collection is either unpredictable or considered unnecessary based on assumptions regarding small particle size and volumes; and optimal debulking is either not possible due to a lack of intravascular visualization or requires very long procedure times. Based on these limitations, current devices are likely to perform poorly in the coronary vasculature where safety and efficacy in *de novo* lesions, ostials, and bifurcations continue to pose great challenges.

[0007] In the past, atherectomy devices have focused on macerating or emulsifying the atherosclerotic plaque such that either it might be considered clinically insignificant enough to remain in the blood stream or that it can be aspirated proximally through small spaces in the catheter main body. When the plaque is not aspirated through the catheter to an external reservoir, the reliability of these devices to produce clinically insignificant embolization has been challenged. Aspiration necessitates that a vacuum be applied to a lumen or annular space within the catheter to remove emulsified tissue. In early clinical evaluations of aspiration, the presence of negative pressure at the distal working assembly caused the artery to collapse around the cutting element. This effect results in more aggressive treatment, dissections and/or perforations. In addition, options for post-procedural analysis of any removed disease are extremely limited or impossible using this methodology.

[0008] Other atherectomy devices include directional atherectomy devices, which use cup-shaped cutters that cut and “turn” the tissue distally into a storage reservoir in the distal tip of the device. This approach preserves the “as cut” nature of the plaque, but requires large distal collection elements. These large distal tip assemblies can limit the capability of the system to access small lesions and may cause additional trauma to the vessel.

[0009] Currently available atherectomy devices also do not include, and are poorly adapted for use with, real time image guidance. Although intravascular diagnostic devices have consistently shown lesions that are significantly eccentric, the typical practice of physicians is to treat target lesions as if they contain concentric disease. This circumferential treatment approach virtually ensures that potentially native arterial wall and healthy vessel will be cut from the vasculature.

[00010] Further, several design challenges are presented by a single use, disposable, and single-direction imaging catheter, such as an atherectomy catheter. For example, obtaining a clear image can be difficult, as nonuniform rotational distortion (“NURD”) can occur in the image as a result of the cutter vibrating or stalling as it encounters different types of tissue. Moreover, the imaging fiber, which runs from the static light source to the rotating distal tip, can become wound up as the catheter is in active (cutting) mode. Further, a motor can be required to drive the imaging assembly at the appropriate revolution rates for imaging, thereby significantly increasing the cost and complexity of the catheter.

[00011] Atherectomy catheter devices, systems and methods that may address some of these concerns are described and illustrated below.

SUMMARY OF THE DISCLOSURE

5 [00012] Described herein are various embodiments of atherectomy catheters.

[00013] In general, in one embodiment, an atherectomy catheter includes an elongate flexible catheter body, an elongate deflectable distal tip coupled to the catheter body at a hinge point, a rotatable cutter near the distal end of the catheter body and a drive shaft extending within the catheter body and configured to rotate the cutter. The atherectomy catheter further includes an optical fiber extending through the drive shaft substantially on-axis with the catheter body and attached to the cutter. The optical fiber is configured to rotate with the drive shaft. The atherectomy catheter further includes a wedge configured to deflect the distal tip away from the catheter body at the hinge point upon axial movement of the drive shaft.

[00014] This and other embodiments can include one or more of the following features. The hinge point can include a pin, and the wedge can be attached to the catheter body and the distal tip through the pin. The wedge can include a distally-facing annular flange configured to interact with a proximally-facing annular flange on the cutter to deflect the distal tip. The wedge can be configured such that proximal movement of the drive shaft causes the distal tip to deflect. The wedge can be configured such that distal movement of the drive shaft causes the distal tip to align axially with the catheter body. The drive shaft can be configured such that, after axial alignment of the distal tip with the catheter body, further distal movement of the drive shaft can move the cutter into the distal tip. The optical fiber can be coupled to the cutter but otherwise free to float within the drive shaft. The optical fiber can be configured to transmit an optical coherence tomography signal. Deflection of the distal tip away from the catheter at the hinge point can expose the cutter. When the distal tip is not deflected, it can be substantially on-axis with the elongate flexible catheter body. The rotatable cutter can be protected by the distal tip when the distal tip is substantially on-axis with the elongate flexible catheter body. The distal tip can include a cutter window therein. The cutter window can have a width that is greater than a diameter of the cutter. The cutter window can be asymmetric.

[00015] In general, in one embodiment, an atherectomy catheter includes an elongate flexible catheter body, a deflectable distal tip coupled to the elongate body, a rotatable cutter near the distal end of the catheter body and a living hinge configured to couple the catheter body and the distal tip. The living hinge is biased in an open configuration where the distal tip is deflected away from a central axis of the catheter body to expose the cutter. The atherectomy catheter further includes a drive shaft extending within the elongate flexible catheter body and configured

to rotate the rotatable cutter. The atherectomy catheter further includes a wedge configured to hold the deflectable distal tip inline with the central axis of the catheter body.

[00016] This and other embodiments can include one or more of the following features. The atherectomy catheter can further include a drive shaft configured to rotate the rotatable cutter.

5 The drive shaft can further be configured to move proximally and distally to engage or disengage the wedge from a matching notch. Proximal movement of the drive shaft can cause the wedge to disengage from the notch and the living hinge to bias the distal tip such that the distal tip is deflected away from the central axis of the catheter. Distal movement of the drive shaft can cause the wedge to engage the notch such that the distal tip is moved inline with the elongate
10 catheter body. The drive shaft can be hollow and can be configured to hold cut tissue therein. The wedge can include a proximal extension from the nosecone. A distal face of the cutter can include a notch configured to mate with the proximal extension from the nosecone. The cutter can be hollow. The atherectomy catheter can further include an imaging element attached to the cutter. The imaging element can be an optical coherence tomography imaging element.

15 Stiffening members

[00017] In general, in one embodiment, an atherectomy catheter includes an elongate catheter body having stiffening members therein, and a rotatable cutter having a distal cutting edge near the distal end of the elongate body. The atherectomy catheter further includes a drive shaft
20 extending through the elongate catheter body and connected to a rotatable cutter. The drive shaft is configured such that axial movement of the drive shaft places compression on the elongate catheter body to cause the elongate catheter body to assume a predetermined shape defined by the placement of the stiffening members.

[00018] This and other embodiments can include one or more of the following features. A proximal end of the elongate body and a distal end of the elongate body can be offset but
25 substantially parallel to one another. The atherectomy catheter can further include a nosecone attached to the elongate catheter body. In some embodiments, there is no hinge between the nosecone and the elongate body. The atherectomy catheter can further include a nosecone attached to the elongate body and a hinge between the nosecone and the elongate body configured, when hinged, to expose the cutter. The drive shaft can be configured such that
30 proximal movement of the drive shaft can deflect the cutter and can activate the hinge to expose the cutter. The atherectomy catheter can further include an imaging element attached to the cutter. The imaging element can be an optical coherence tomography imaging element.

[00019] In general, in one embodiment, an atherectomy catheter includes an elongate shaft and a distal tip attached to the elongate shaft, the distal tip including a proximal-facing cutting
35 edge configured to scrape tissue from a vessel wall.

[00020] This and other embodiments can include one or more of the following features. The distal tip can further include a distal-facing fluted cutting edge. The atherectomy catheter can further include an imaging element attached to the elongate shaft. The imaging element can be an optical coherence tomography imaging element.

5 [00021] In general, in one embodiment, an atherectomy catheter includes an elongate catheter body having a fixed jog therein. The fixed jog includes a distal inflection point and a proximal inflection point. The inflection points have opposite curvatures. The atherectomy catheter further includes a rotatable cutter having a distal cutting edge near the distal end of the elongate body. A distance from the distal cutting edge to the distal inflection point is less than a distance
10 from the distal inflection point to the proximal inflection point.

[00022] This and other embodiments can include one or more of the following features. An angle of the distal inflection point can be between 120 and 180 degrees, and an angle of the proximal inflection point can be between 120 and 180 degrees. The angle of the distal inflection point can be 140 degrees and the angle of the proximal inflection point can be 160 degrees. The
15 catheter can further include a nosecone attached to the elongate body and can have a cutting window therein configured to expose the cutter. The cutting window can be positioned along a same side of the elongate body as a convex portion of the distal inflection point. In one embodiment, there is no hinge between the nosecone and the elongate body. The atherectomy catheter can further include a hinge between the nosecone and the elongate body configured,
20 when hinged, to expose the cutter. A proximal end of the elongate body and a distal end of the elongate body can be offset but substantially parallel to one another. The fixed jog can include pre-deflected shaped-set ribbon segments. The atherectomy catheter can further include an imaging element attached to the cutter. The imaging element can be an optical coherence tomography imaging element.

25 [00023] Methods of using these atherectomy devices are also described herein.

BRIEF DESCRIPTION OF THE DRAWINGS

[00024] The novel features of the invention are set forth with particularity in the claims that follow. A better understanding of the features and advantages of the present invention will be
30 obtained by reference to the following detailed description that sets forth illustrative embodiments, in which the principles of the invention are utilized, and the accompanying drawings of which:

[00025] FIG. 1 shows a variation of a distal end of an atherectomy catheter that includes both cutting and imaging elements. This embodiment includes a hinged nosecone that is activated by

tensioning the drive shaft to position the cutter and imaging element against a distal wedge.

through use of a distal wedge

[00026] FIG. 2A shows a section view of a portion of the catheter of FIG. 1 with the nosecone in a closed position. FIG. 2B shows a section view of a portion of the catheter of FIG. 1 with the nosecone in an open position.

[00027] FIGS. 3A-3F show an atherectomy catheter having a living hinge mechanism and a nosecone wedge to open or close the nosecone. FIG. 3A is an outer view of the device with the nosecone closed. FIG. 3B is a cross-section of the device with the nosecone closed. FIG. 3C is an isometric view of the device with the nosecone closed. FIG. 3D is an outer view of the device with the nosecone open. FIG. 3E is a cross-section of the device with the nosecone open. FIG. 3F is an isometric view of the device with the nosecone open.

[00028] FIGS. 4A-4B show various embodiments of a living hinge. FIG. 4A shows a variety of different potential cuts for use as a living hinge. FIG. 4B shows the resulting deflection of one of the cuts of FIG. 4A.

[00029] FIG. 5A shows a variation of a distal end of an atherectomy catheter that includes both cutting and imaging elements. This embodiment includes a mechanism to deflect the cutter out of a window and utilizes a fixed jog in the catheter outer shaft. FIG. 5B is a schematic showing the dimensions and angles of the fixed jog.

[00030] FIG. 6 shows placement of the atherectomy device of FIG. 5A in a vessel.

[00031] FIG. 7A shows a variation of a distal end of an atherectomy catheter that includes stiffening members that cause the catheter to deform to a predetermined configuration when activated. FIG. 7B is a schematic showing the stiffening members of FIG. 7A.

[00032] FIG. 8A shows a variation of a distal end of a catheter with both cutting and imaging elements. This embodiment includes a sharp directional blade configured to scrape tissue away from edges of a vessel wall. FIG. 8B shows the imaging components of the catheter of FIG. 8A.

DETAILED DESCRIPTION

[00033] Described herein are variations of atherectomy devices having imaging capabilities. In general, the atherectomy devices include an elongate flexible catheter body and an annular rotatable cutter configured to rotate to shear tissue away from the vessel wall. In other embodiments, rather than having an annular cutter, the atherectomy catheter can include a distal tip having a proximal-facing cutting edge configured to scrape tissue away from the vessel wall.

[00034] The atherectomy devices can further include on-board imaging, such as optical coherence tomography imaging. The optical fiber for the OCT imaging can, for example, extend substantially on-axis with the catheter body. In some embodiments, the optical fiber can be

attached to the rotatable cutter and configured to rotate therewith. In other embodiments, the optical fiber can be attached to a separate imaging shaft.

5 [00035] In some embodiments, the atherectomy catheters described herein can include a nosecone that deflects to expose a cutter. The deflection can occur, for example, by pulling or pushing on a drive shaft to activate a wedge. The deflection can also occur through a pre-biased living hinge.

[00036] In some embodiments, the atherectomy catheters described herein can include a fixed or deflectable jog in the catheter configured to urge the cutter against the wall.

10 [00037] It should be understood that features of any of the embodiments described herein can be combined or replaced with features of other embodiments.

[00038] FIGS. 1-2B show an example of an atherectomy catheter including a nosecone that deflects to expose a cutter. Referring to FIG. 1, an atherectomy catheter 100 can include a catheter body 101, a cutter 103 at a distal end of the catheter body 101, and a nosecone 105 at a distal end of the catheter body 101. The nosecone 105 can further include a cutting window 107 through which the cutting edge 112 of the cutter 103 can be exposed. The nosecone 105 can be configured to deflect away from the longitudinal axis of the catheter body at an angle, such as through a wedge. In use, this deflection can expose the cutter 103 through the cutting window 107 and/or radially push the cutter 103 into a wall of the vessel in which the atherectomy catheter is inserted.

20 [00039] Referring to FIGS. 2A-2B, the cutter 103 can be positioned between the catheter body 101 and the nosecone 105. A cutting window 107 in the nosecone can be configured to expose the cutter 103 therethrough. Thus, the cutting window 107 can have a width that is greater than the diameter of the cutter 103. In some embodiments, as shown in FIGS. 2A-2B, the cutter 103 can be an annular cutter with a sharp distal edge 112. The cutter 103 can be attached to a drive shaft 113 configured to rotate the cutter 103. Further, the catheter body 101 can include an outer shaft 111 outside of and concentric with the drive shaft 113.

25 [00040] Further, referring still to FIGS. 2A-2B, the atherectomy catheter 100 can include an imaging element 192, such as an OCT imaging element, proximal to the cutting edge 112 of the cutter 103. The imaging element 192 can include an optical fiber 197 that runs substantially on-axis through the center of the elongate body, such as through a drive shaft 113, to transmit the OCT signal. The optical fiber 197 can be attached at the distal end to the cutter 103, such as in a slot 170 in the cutter 103. The optical fiber 197 can otherwise be free to float within the catheter body or drive shaft 113. In other embodiments, the optical fiber 197 can be attached to the drive shaft 113 along the length thereof.

[00041] As shown in FIGS. 2A-2B, a reflective element 199, such as a mirror, can further be located within the slot 170 in the cutter 103 to radially direct light from the optical fiber 197 into the adjacent tissue (through the cutter window 107). The reflective element 199 can be oriented at an angle relative to the axis of the optical fiber 197, such as at a 35-55 degree angle, e.g. 45
5 degree angle, to reflect light into the tissue. The distal end of the optical fiber 197 can be located less than 3mm from the cutting edge, such as less than 1.5mm from the cutting edge, such as less than or equal to 1.2mm, such as less than or equal to 1mm. By having the imaging element 192 close to the cutting edge, the resulting image can advantageously align with the portions of the vessel being cut.

10 [00042] In use, the outer shaft 111 can be configured to be turned, such as turned manually, to position the cutter window 107, cutter 103 and/or the imaging element 192 toward the desired location. Rotation of the cutter can provide cutting due to the rotational motion of the cutting edge and provide the rotation necessary to image the vessel wall via the imaging element. The drive shaft can be rotated at up to 2,000 rpm, such as approximately 1,000 rpm in a single
15 direction, though rotation in both directions or at higher or lower speeds is possible.

[00043] Referring to FIGS. 2A and 2B, the drive shaft 113 can further be configured to translate axially in the proximal and/or distal directions. Such axial movement of the drive shaft 113 can open and/or close the nosecone 105 to expose or conceal and protect the cutting edge 112 of the cutter 103. For example, as shown in FIGS. 2A-2B, the cutter can include an annular
20 wedge 131 that is attached to the outer shaft 111 (or a distal housing around the outer shaft) and nosecone 105 through a pin 135. The wedge 131 can include a distally-facing annular flange that includes a lower lip 143 and an upper slanted surface 137. Further, the cutter 103 can include a proximally-facing annular flange 133. As described further below, the interaction between these two flanges 137/143 and 133 can cause the nosecone 105 to open. Further, the
25 wedge 131 can include a proximally-facing annular flange 145 while the cutter 103 can include a distally-facing annular flange 145. As described below, the interaction between these two flanges 145, 147 can cause the nosecone 105 to close.

[00044] Thus, in one embodiment, proximal retraction of the drive shaft 113 opens the nosecone 105 to expose the cutter. For example, as shown in FIG. 2A, when the drive shaft 113
30 is translated proximally, the cutter 103 can retract proximally until it contacts the wedge 131 that is attached to the outer shaft 111 and nosecone 105 through a pin 135. As the cutter flange 133 pushes on the lip 143 of the wedge flange, the lip 143 will rotate downward, causing the wedge 131 to pivot away from the outer shaft 111, rotating about the axis of the pin 135. The rotation of the wedge 131 about the pin 135 will likewise cause the nosecone 105 to rotate, thereby
35 dropping the nosecone away from the central axis and exposing the cutting edge 112, as shown

in FIG. 2B. The cutting window 107 can have an opening that is larger than the diameter of the cutter 103 and cutting edge 112 to allow the cutter 103 to protrude out of the nosecone 105. As shown in FIG. 2B, when the nosecone 105 is in the fully open position, the cutter fits snugly against the inner surface of the lip 143 while the slanted surface 137 and the cutter flange 133 will rest against one another in a coplanar position that is approximately perpendicular to the central axis of the elongate body.

[00045] In one embodiment, distal movement of the drive shaft 113 closes the nosecone 105. For example, as shown in FIG. 2B, when the drive shaft 113 is pushed distally, the flange 147 on the cutter will hit the flange 145 on the wedge. As a result, the flange 145 will be pushed distally, causing the wedge 131 to rotate up about the pin 135, thereby causing the nosecone 105 to also rotate upwards back into alignment with the elongate body, as shown in FIG. 2A. The return of the nosecone 105 to the closed position can also be aided by having a tight concentric fit between a proximal end of the nosecone 105 and the outer shaft 111 such that once the proximal end of the nosecone 105 begins to align with outer shaft 100, it is forced upwards and into alignment. A handle can be used to control the rotation or translation of the driveshaft. Exemplary handles are described in co-pending Patent Applications: U.S. Patent Application No. 13/654,357, titled "ATHERECTOMY CATHETERS AND NON-CONTACT ACTUATION MECHANISM FOR CATHETERS," filed 10/17/2012; International Patent Application titled "BALLOON ATHERECTOMY CATHETERS WITH IMAGING," filed herewith; U.S. Patent Application No. 12/829,277, titled "ATHERECTOMY CATHETER WITH LATERALLY-DISPLACEABLE TIP," filed 7/1/2010, Publication No. US-2011-0004107-A1; U.S. Patent Application No. 13/175,232, titled "ATHERECTOMY CATHETERS WITH LONGITUDINALLY DISPLACEABLE DRIVE SHAFTS," filed 7/1/2011, Publication No. US-2012-0046679-A1; U.S. Patent Application No. 13/675,867, titled "OCCLUSION-CROSSING DEVICES, ATHERECTOMY DEVICES, AND IMAGING," filed 11/13/2012, the entireties of which are incorporated by reference herein.

[00046] Further, the atherectomy catheter 100 can include a mechanism for packing tissue into the nosecone, such as by moving the drive shaft axially. In one embodiment, movement of the drive shaft 113 distally closes the nosecone 105. Moving the drive shaft 113 further distally will move the cutter 103 into the nosecone 105, thus packing tissue with a distal face of the cutter 103. In some embodiments, the housing window 107 can be asymmetric to avoid having the cutter crash into the edge of the cutter window 107, as described further in International Patent Application titled "BALLOON ATHERECTOMY CATHETERS WITH IMAGING," filed herewith, the entirety of which is incorporated herein by reference.

[00047] In one embodiment, the atherectomy catheter 100 includes a guidewire lumen in the nosecone 105, such as a monorail, for use in guiding the catheter. Advantageously, the guidewire lumen can be used as a marker during imaging.

5 [00048] In one embodiment, the atherectomy catheter 100 includes a flush port close to the cutter 103. The flush port can be used to deliver flushing fluid to the region of imaging, thereby improving image quality. In some embodiments, the flushing can be activated through a mechanism on the handle of the device.

[00049] FIGS. 3A-3F show another exemplary atherectomy catheter 200 that includes a nosecone that deflects to expose a cutter. The atherectomy catheter 200 can include a catheter
10 body 201, a cutter 203 at a distal end of the catheter body 201, and a nosecone 205 at a distal end of the catheter body 203. The nosecone 205 (or a distal housing connecting the nosecone 205 and catheter body 201) can further include a cutting window 207 through which the cutting edge 212 of the cutter 203 can be exposed. As shown in FIGS. 3D-3F, the nosecone 205 can be configured to deflect away from the longitudinal axis of the catheter body 201 at an angle, such
15 as through a living hinge mechanism. In use, this deflection can expose the cutter 203 through the cutting window 207 and/or radially push the cutter 203 into a wall of the vessel in which the atherectomy catheter 200 is inserted by deflecting the nosecone 205 against the opposite vessel wall.

[00050] Referring to FIGS. 3D-3F, the cutter 203 can be positioned between the catheter body
20 201 and the nosecone 205. The cutting window 207 can be configured to expose the cutter 203 therethrough. Thus, the cutting window 207 can have a width that is greater than the diameter of the cutter 203. In some embodiments, as shown in FIGS. 3A-3F, the cutter 203 can be an annular cutter with a sharp distal edge 212. The cutter 203 can be attached to a drive shaft 213 configured to rotate the cutter 203. Further, the catheter body 201 can include an outer shaft 211
25 outside of and concentric with the drive shaft 213.

[00051] As shown in FIGS. 3C and 3F, the cutter 203 and drive shaft 213 can be hollow, thereby providing a collection chamber or feed-through channel for tissue cut during the atherectomy procedure. Advantageously, by feeding tissue into the hollow drive shaft 213 rather than the nosecone, the nosecone 205 can be shorter, such as less than 1" or less than 0.5". By
30 having a shorter nosecone, the distance that the atherectomy catheter has to travel through the diseased or occluded vessel before cutting is advantageously decreased.

[00052] In some embodiments, a wedged geometry (which can be a sloped surface or any other feature that mechanically interlocks with a mating feature) in the nosecone can be used to control the opening and closing of the nosecone 205. Further, in some embodiments, the

catheter 200 can include a shape memory living hinge mechanism 275 configured to bias the nosecone open or close.

5 [00053] For example, as shown in FIGS. 3A-3F, the cutter 203 can include a notch 271 in the distal end thereof (which can extend all the way through the cutter to make the cutter hollow, as described above). Further, the nosecone 205 can include a wedge 279 extending therefrom and configured to mate within the notch 271 in the cutter 203. Moreover, a living hinge mechanism 275 can extend between the catheter body 201 and the nosecone 205. The living hinge mechanism 275 can be a single piece of material, such as a single piece of shape-memory alloy, such as nickel titanium (e.g., nitinol). Cuts 277 (labeled in FIG. 3A) in the living hinge
10 mechanism 275 can ensure that the nosecone opens in such a way as to expose the cutter. The living hinge mechanism 275 can be biased in an open configuration (such as the configuration shown in FIGS. 3C-3F). Further, a proximally-extending tongue 251 in the living hinge mechanism 275 can be configured to limit the amount of deflection that the nosecone 205 can undergo.

15 [00054] To open the nosecone 205, the drive shaft 213 can be pulled proximally, thereby pulling the cutter 203 proximally. By doing so, the notch 271 of the cutter 203 can disengage from the wedge 279 of the nosecone. Because the hinge mechanism 275 is biased to an open configuration, releasing the wedge 279 from the notch 271 will cause the nosecone 205 to deflect away from the catheter body 201, thereby exposing the cutting edge 212 of the cutter 203
20 through the cutting window 207.

[00055] To close the nosecone, the drive shaft 213 can be pushed distally. Pushing distally can cause the notch 271 of the cutter 203 to reengage with the wedge 279, forcing the wedge 279 back into alignment with the cutter 203 and therefore the catheter body 201. This mechanism of closing can also shear tissue from the vessel that is stuck between the wedge 279 and the notch
25 271, thereby fully completing the cut.

[00056] Referring to FIGS. 4A-4B, alternate living hinge mechanisms are possible. In general, the living hinge mechanism can include cuts in the tube that are configured to ensure that the hinge pivots in the proper orientation and is biased in the open configuration.

30 [00057] As shown in FIG. 4A, a living hinge can include one or more of a variety of different types of cuts to provide deflection in a tube 1609, such as cuts 1604, 1605, and 1606. Such deflecting cuts 1604, 1605, 1606 can be primarily on one side of the tube so as to leave a stemmed hinged portion on the opposite side of the tube. For example, the deflection of cut 1606 is shown in FIG. 4B. In some embodiments, rather than using the cut pattern to deflect the device, the cut pattern can be used to return bias the nosecone back in line with the device, such as

cuts 1601, 1602, and 1603. Such return bias cuts 1601, 16502, 1603 can include notches on both sides of the tube configured to provide both a hinge point and a return bias.

5 [00058] The atherectomy catheter 200 can further advantageously include a guidewire lumen 254 extending through the nosecone 205. A guidewire can thus be inserted through the hollow drive shaft 213, through the hollow cutter 203, and through the guidewire lumen 213. In an alternative embodiment, the guidewire lumen could be limited to the length of the nosecone 205, such as a monorail, for use in guiding the catheter. Advantageously, the guidewire lumen can be used as a marker during imaging.

10 [00059] Similar to the atherectomy catheter 100, the atherectomy catheter 200 can further include an imaging element, such as an OCT imaging element. In some embodiments, the optical fiber for the OCT imaging element can be attached to the outside of the drive shaft 213 to spin therewith. In other embodiments, a separate imaging shaft can be placed around the drive shaft 213 to hold the optical fiber 213. Further, the direction and speed of rotation, flush port, and other features described with respect to catheter 100 can further be incorporated into catheter
15 200.

[00060] In some embodiments, the atherectomy catheters described herein can include a jog in the catheter body that urges the atherectomy cutter against the vessel wall.

[00061] FIGS. 5A-6 show an exemplary catheter 300 that include a jog in the catheter body that urges the atherectomy cutter against the vessel wall. Referring to FIGS. 5A and 5B, an
20 atherectomy catheter 300 can include a catheter body 301, a cutter 303 at a distal end of the catheter body 301, and a nosecone 305 at a distal end of the catheter body 301. The nosecone 305 can include a cutting window 307 configured to allow the cutter 303 to cut therethrough. The catheter 301 can further include a fixed jog 333 in the catheter body 301 to radially push the cutter 303 against the vessel wall.

25 [00062] As shown in FIGS. 5A and 5B, the fixed jog 333 can be configured such that the cutting window 307 is on the outermost portion of the jog 333 (thereby allowing the cutting window 307 to be urged against a vessel wall in use). In one embodiment, the fixed jog 333 can be formed, for example, by pre-deflected shaped-set nitinol ribbon segments embedded in the outer shaft. The fixed jog 333 can have two inflection points 355, 366 of opposite curvature
30 (i.e., one curving up and the other curving down) so as to form an approximate "s" shape. In one embodiment, the s-shape can be configured such that a distal end of the catheter body 301 is offset from, but substantially parallel to, a proximal end of the catheter body 301. In other embodiments, the distal end and proximal ends of the catheter body 301 can be at a slight angle to one another so as to control the angle of cutter engagement with the vessel wall.

[00063] Thus, as shown in FIG. 5B, the “s-shaped” of the fixed jog 333 can have an angled section 337 that includes the inflection points of the jog. The angled section 337 can have a length b that extends from the distal end of the inflection point 355 to the proximal inflection point 366. Further, the fixed jog 333 can include a cutter section 335 having a length a that extends from the cutting edge 312 to the distal inflection point 355. Further, there can be distal angle 1 at the distal end of the “s-shape” and a proximal angle 2 at the proximal end of the “s-shape.” These lengths (a , b) and angles (1 , 2) can be tuned to achieve the desired jog or offset in order to obtain optimum apposition to tissue walls. For example, the length a can be shorter than the length b to ensure that the cutter is as close to the angle 1 as possible, thereby providing better apposition of the cutter. The angles 1 and 2 can be between 120 and 180 degrees, such as between 140 and 160 degrees. In one example, the length a is between 5 and 10mm, the length b is between 10 and 15mm, the angle 1 is 140 degrees and angle 2 is 160 degrees for a catheter configured to be used in a vessel having a 2.5-4mm diameter. In an alternative embodiment, rather than having a fixed angle 1 , a flexible section can be created in the catheter just proximal to the cutter such that, once the angle 2 deflects the catheter to approximately the appropriate position, the flexible section can bend to align the cutter with the edge of the vessel.

[00064] Referring to FIG. 6, the fixed jog 333 can advantageously radially push the distal end of the catheter against a vessel wall 400, thereby enabling optimized cutting and/or imaging of the vessel. The fixed jog 333 can advantageously be used alone or in combination with a mechanism to deflect the nosecone (such as described above with respect to catheters 100 and 200). If used alone, the cutting window 307 can be optimized so as to allow for automatic invagination of tissue into the cutting window 307. Having the nosecone 305 not deflect can advantageously prevent the cutter 303 from escaping from the nosecone 305 during packing. Further, having the fixed jog 333 can advantageously eliminate having to use additional mechanisms to force a jog mid-surgery, such as pulling or pushing on a shaft, thereby enhancing both ease of use and enhancing image stability.

[00065] Some or all of the type of cutter, imaging element configuration, packing of tissue, guidewire, and flush port of catheter 100 can likewise be incorporated into catheter 300.

[00066] FIGS. 7A-7B show an exemplary catheter 700 that include a jog in the catheter body that urges the atherectomy cutter against the vessel wall.

[00067] Referring to FIGS. 7A and 7B, in some embodiments, a catheter 700, can be deflected into a jog 733 by tensile and compressive interaction between an inner shaft 713 (which can be a drive shaft for a cutter) and outer shaft 711 that are fixed together at the distal end but free to move relative to one another at the proximal end. The outer shaft 711 can include stiffening members 777a,b, such as nitinol or stainless steel, stiffening members, configured to

bias the deflection to a set shape. As shown in Figure 7B, there can be two stiffening members 777a, 777b that can be axially aligned with the outer shaft 711 and axially and radially offset from one another. As a result, when compression is applied on the outer shaft 711 (such as by pulling on the inner shaft 713), the portions 779a,b of the outer shaft opposite to the stiffening members 777a,b will contract. The contraction of the two portions 779a, 779b will result in an s-shape similar to the catheter 300 shown in FIG. 6. As a result, the catheter will deflect into jog or s-shaped configuration where the distal end of the shaft is offset and parallel to the main shaft body. It is to be understood that other numbers and arrangements of stiffening members are possible, as are other resulting jog shapes.

10 [00068] Similar to the fixed jog of the catheter 300, the jog mechanism of catheter 700 can be combined with a mechanism to deflect the nosecone (such as described above with respect to catheters 100 and 200). If used in combination, placing a first amount of tension on the drive shaft may deflect the cutter, as described with respect to catheter 100. Placing further tension on the drive shaft can cause the cutter to engage the distal end of the outer shaft, resulting in
15 compression being applied to the outer shaft. Such compression can cause the outer shaft to assume a predetermined shape. Moreover, the jog mechanism of catheter 700 can be used with any of the other features of the catheters described herein (such as OCT imaging, rotating cutters, etc.).

[00069] In some embodiments, an atherectomy catheter can include a sharp blade on the distal
20 end thereof. For example, referring to FIGS. 8A and 8B, in one embodiment, a catheter 800 can include a distal tip 888 having a cutting edge 891, such as a sharp blade, thereon. The distal tip 888 can be attached to a shaft 813. As shown in FIGS. 8A and 8B, the cutting edge 899 can be directional, e.g., can face in a proximal direction. The cutting edge 899 can be activated by pulling proximally on the shaft 813. In use in a vessel, when a proximal force is placed on the
25 shaft 813, the cutting edge 899 can be pulled proximally and scrape, cut, or shave tissue from the inner walls of the vessel.

[00070] In some embodiments, the cutting edge 899 can be further activated ultrasonically or with an oscillating motor or cam system to create slight vibrations in the cutter, thereby assisting the cutting as the blade 888 is pulled proximally. The catheter 800 can include a retractable
30 sheath 891 that can be configured to cover and shield the cutting edge 899 until the cutting edge 899 has reached the desired location to prevent inadvertent cutting of nontargeted tissue.

[00071] As shown in FIG. 8B, the distal tip 888 of the catheter 800 can include a distal drilling mechanism, such as a helical fluted cutting edge 893 on the distal surface of the tip 888. Further, the distal blade 888 can be configured to rotate, such as with the shaft 813. Having a

rotatable fluted distal end can advantageously be used to cross chronic total occlusions (CTOs) and gain access to completely blocked vessels.

5 [00072] In use, the cutting edge 899 and/or distal fluted cutting edge 893 can remain covered by the retractable sheath 891. Once the catheter 800 is through the lesion, the retractable sheath 891 can be pulled back to expose the cutting edge 899 of the distal tip 888 to cut tissue. The device can then be pulled proximally across the lesion, cutting the targeted lesion as it is withdrawn. In embodiments (such as shown in FIG. 8B) where a distal cutting edge 893 is included, the distal cutting edge 893 can be rotated to help drill through the occlusion in one direction, followed by scraping of the material in the opposite direction.

10 [00073] As further shown in FIG. 8B, the catheter 800 can further include imaging, such as an optical fiber 897 for OCT. The imaging element can be present on the outer sheath 891, which can turn with the distal tip 888 during CTO crossing to provide radial imaging. After the catheter 800 is through the CTO, the sheath 891 can be pulled back slightly to expose the cutting edge 891. In some embodiments, the optical fiber 897 can remain rotationally stable (i.e. not be rotated). In these embodiments, as the cutter/sheath assembly is pulled proximally, the imaging element 891 can detect a linear view of the tissue being cut. In other embodiments, the outer sheath 891, and thus the optical fiber 897, can be rotated so as to obtain a 360 degree view of the vessel.

15 [00074] The catheters described herein can be driven using a drive assembly. Exemplary drive assemblies are described in co-pending Patent Applications: International Patent Application titled "ATHERECTOMY CATHETER DRIVE ASSEMBLIES," filed herewith and U.S. Patent Application No. 13/654,357, titled "ATHERECTOMY CATHETERS AND NON-CONTACT ACTUATION MECHANISM FOR CATHETERS," filed 10/17/2012; both of which are incorporated by reference in their entireties.

20 [00075] Further, as described above, the catheters described herein can be configured to provide imaging, such as optical coherence tomography imaging. Exemplary imaging systems are described in co-pending applications: U.S. Patent Application No. 12/790,703, titled "OPTICAL COHERENCE TOMOGRAPHY FOR BIOLOGICAL IMAGING," filed 5/28/2010, Publication No. US-2010-0305452-A1; U.S. Patent Application No. 12/829,267, titled
25 "CATHETER- BASED OFF-AXIS OPTICAL COHERENCE TOMOGRAPHY IMAGING SYSTEM," filed 7/1/2010, Publication No. US-2010-0021926-A1; International Patent Application titled "OPTICAL COHERENCE TOMOGRAPHY WITH GRADED INDEX FIBER FOR BIOLOGICAL IMAGING," filed herewith, all of which are incorporated by reference in their entireties. Further, although many of the embodiments described herein were
30 described as having the optical fiber attached to the cutter, other variations are possible. For
35

example, the optical fiber can be attached to a separate imaging shaft extending concentric to or parallel with the drive shaft, as described in International Patent Application titled "BALLOON ATHERECTOMY CATHETERS WITH IMAGING," filed herewith, which is incorporated herein by reference.

5 [00076] Additional details pertinent to the present invention, including materials and manufacturing techniques, may be employed as within the level of those with skill in the relevant art. The same may hold true with respect to method-based aspects of the invention in terms of additional acts commonly or logically employed. Also, it is contemplated that any optional feature of the inventive variations described may be set forth and claimed independently, or in
10 combination with any one or more of the features described herein. Likewise, reference to a singular item includes the possibility that there are a plurality of the same items present. More specifically, as used herein and in the appended claims, the singular forms "a," "and," "said," and "the" include plural referents unless the context clearly dictates otherwise. It is further noted that the claims may be drafted to exclude any optional element. As such, this statement is intended to
15 serve as antecedent basis for use of such exclusive terminology as "solely," "only" and the like in connection with the recitation of claim elements, or use of a "negative" limitation. Unless defined otherwise herein, all technical and scientific terms used herein have the same meaning as commonly understood by one of ordinary skill in the art to which this invention belongs. The breadth of the present invention is not to be limited by the subject specification, but rather only
20 by the plain meaning of the claim terms employed.

[00077] When a feature or element is herein referred to as being "on" another feature or element, it can be directly on the other feature or element or intervening features and/or elements may also be present. In contrast, when a feature or element is referred to as being "directly on" another feature or element, there are no intervening features or elements present. It will also be
25 understood that, when a feature or element is referred to as being "connected", "attached" or "coupled" to another feature or element, it can be directly connected, attached or coupled to the other feature or element or intervening features or elements may be present. In contrast, when a feature or element is referred to as being "directly connected", "directly attached" or "directly coupled" to another feature or element, there are no intervening features or elements present.
30 Although described or shown with respect to one embodiment, the features and elements so described or shown can apply to other embodiments. It will also be appreciated by those of skill in the art that references to a structure or feature that is disposed "adjacent" another feature may have portions that overlap or underlie the adjacent feature.

[00078] Terminology used herein is for the purpose of describing particular embodiments
35 only and is not intended to be limiting of the invention. For example, as used herein, the singular

forms "a", "an" and "the" are intended to include the plural forms as well, unless the context clearly indicates otherwise. It will be further understood that the terms "comprises" and/or "comprising," when used in this specification, specify the presence of stated features, steps, operations, elements, and/or components, but do not preclude the presence or addition of one or more other features, steps, operations, elements, components, and/or groups thereof. As used herein, the term "and/or" includes any and all combinations of one or more of the associated listed items and may be abbreviated as "/".

[00079] Spatially relative terms, such as "under", "below", "lower", "over", "upper" and the like, may be used herein for ease of description to describe one element or feature's relationship to another element(s) or feature(s) as illustrated in the figures. It will be understood that the spatially relative terms are intended to encompass different orientations of the device in use or operation in addition to the orientation depicted in the figures. For example, if a device in the figures is inverted, elements described as "under" or "beneath" other elements or features would then be oriented "over" the other elements or features. Thus, the exemplary term "under" can encompass both an orientation of over and under. The device may be otherwise oriented (rotated 90 degrees or at other orientations) and the spatially relative descriptors used herein interpreted accordingly. Similarly, the terms "upwardly", "downwardly", "vertical", "horizontal" and the like are used herein for the purpose of explanation only unless specifically indicated otherwise.

[00080] Although the terms "first" and "second" may be used herein to describe various features/elements, these features/elements should not be limited by these terms, unless the context indicates otherwise. These terms may be used to distinguish one feature/element from another feature/element. Thus, a first feature/element discussed below could be termed a second feature/element, and similarly, a second feature/element discussed below could be termed a first feature/element without departing from the teachings of the present invention.

[00081] As used herein in the specification and claims, including as used in the examples and unless otherwise expressly specified, all numbers may be read as if prefaced by the word "about" or "approximately," even if the term does not expressly appear. The phrase "about" or "approximately" may be used when describing magnitude and/or position to indicate that the value and/or position described is within a reasonable expected range of values and/or positions. For example, a numeric value may have a value that is +/- 0.1% of the stated value (or range of values), +/- 1% of the stated value (or range of values), +/- 2% of the stated value (or range of values), +/- 5% of the stated value (or range of values), +/- 10% of the stated value (or range of values), etc. Any numerical range recited herein is intended to include all sub-ranges subsumed therein.

CLAIMS

What is claimed is:

1. An atherectomy catheter comprising:
5 an elongate flexible catheter body;
an elongate deflectable distal tip coupled to the catheter body at a hinge point;
a rotatable cutter near the distal end of the catheter body;
a drive shaft extending within the catheter body and configured to rotate the cutter;
an optical fiber extending through the drive shaft substantially on-axis with the catheter
10 body and attached to the cutter, the optical fiber configured to rotate with the drive shaft; and
a wedge configured to deflect the distal tip away from the catheter body at the hinge point
upon axial movement of the drive shaft.
2. The atherectomy catheter of claim 1, wherein the hinge point includes a pin, and wherein
15 the wedge is attached to the catheter body and the distal tip through the pin.
3. The atherectomy catheter of claim 1, wherein the wedge includes a distally-facing
annular flange configured to interact with a proximally-facing annular flange on the cutter to
deflect the distal tip.
20
4. The atherectomy catheter of claim 1, wherein the wedge is configured such that proximal
movement of the drive shaft causes the distal tip to deflect.
5. The atherectomy catheter of claim 1, wherein the wedge is configured such that distal
25 movement of the drive shaft causes the distal tip to align axially with the catheter body.
6. The atherectomy catheter of claim 5, wherein the drive shaft is configured such that, after
axial alignment of the distal tip with the catheter body, further distal movement of the drive shaft
moves the cutter into the distal tip.
30
7. The atherectomy catheter of claim 1, wherein the optical fiber is coupled to the cutter but
is otherwise free to float within the drive shaft.
8. The atherectomy catheter of claim 1, wherein the optical fiber is configured to transmit
35 an optical coherence tomography signal.

9. The atherectomy catheter of claim 1, wherein deflection of the distal tip away from the catheter body at the hinge point exposes the cutter.

5 10. The atherectomy catheter of claim 1, wherein, when the distal tip is not deflected, it is substantially on-axis with the elongate flexible catheter body.

11. The atherectomy catheter of claim 1, wherein the rotatable cutter is protected by the distal tip when the distal tip is substantially on-axis with the elongate flexible catheter body.

10

12. The atherectomy catheter of claim 1, wherein the distal tip includes a cutter window therein.

13. The atherectomy catheter of claim 12, wherein the cutter window has a width that is
15 greater than a diameter of the cutter.

14. The atherectomy catheter of claim 12, wherein the cutter window is asymmetric.

20 15. An atherectomy catheter comprising:
an elongate flexible catheter body;
a deflectable distal tip coupled to the elongate body;
a rotatable cutter near the distal end of the catheter body;
a living hinge configured to couple the catheter body and the distal tip, the living hinge
25 biased in an open configuration where the distal tip is deflected away from a central axis of the
catheter body to expose the cutter;
a drive shaft extending within the elongate flexible catheter body and configured to rotate
the rotatable cutter; and
a wedge configured to hold the deflectable distal tip inline with the central axis of the
30 catheter body.

16. The atherectomy catheter of claim 15, further comprising a drive shaft configured to
rotate the rotatable cutter, the drive shaft further configured to move proximally and distally to
engage or disengage the wedge from a mating notch.

35

17. The atherectomy catheter of claim 16, wherein proximal movement of the drive shaft causes the wedge to disengage from the notch and the living hinge to bias the distal tip such that the distal tip is deflected away from the central axis of the catheter.

5 18. The atherectomy catheter of claim 16, wherein distal movement of the drive shaft causes the wedge to engage the notch such that the distal tip is moved inline with the elongate catheter body.

10 19. The atherectomy catheter of claim 16, wherein the drive shaft is hollow and configured to hold cut tissue therein.

20. The atherectomy catheter of claim 15, wherein the wedge is a proximal extension from the nosecone.

15 21. The atherectomy catheter of claim 15, wherein a distal face of the cutter includes a notch configured to mate with the wedge.

22. The atherectomy catheter of claim 15, wherein the cutter is hollow.

20 23. The atherectomy catheter of claim 15, further comprising an imaging element attached to the cutter.

24. The atherectomy catheter of claim 23, wherein the imaging element is an optical coherence tomography imaging element.

25

25. An atherectomy catheter comprising:
an elongate catheter body having stiffening members therein;
a rotatable cutter having a distal cutting edge near the distal end of the elongate body; and
a drive shaft extending through the elongate catheter body and connected to a rotatable
30 cutter, wherein the drive shaft is configured such that axial movement of the drive shaft places
compression on the elongate catheter body to cause the elongate catheter body to assume a
predetermined shape defined by the placement of the stiffening members

35 26. The atherectomy catheter of claim 25, wherein a proximal end of the elongate body and a distal end of the elongate body are offset but substantially parallel to one another.

27. The atherectomy catheter of claim 25, further comprising a nosecone attached to the elongate catheter body, wherein there is no hinge between the nosecone and the elongate body.

5 28. The atherectomy catheter of claim 25, further comprising a nosecone attached to the elongate body and a hinge between the nosecone and the elongate body configured, when hinged, to expose the cutter.

10 29. The atherectomy catheter of claim 28, wherein the drive shaft is configured such that proximal movement of the drive shaft deflects the cutter and activates the hinge to expose the cutter.

30. The atherectomy catheter of claim 25, further comprising an imaging element attached to the cutter.

15

31. The atherectomy catheter of claim 30, wherein the imaging element is an optical coherence tomography imaging element.

32. An atherectomy catheter comprising:

20

an elongate shaft; and

a distal tip attached to the elongate shaft, the distal tip including a proximal-facing cutting edge configured to scrape tissue from a vessel wall.

25 33. The atherectomy catheter of claim 32, wherein the distal tip further includes a distal-facing fluted cutting edge.

34. The atherectomy catheter of claim 32, further comprising an imaging element attached to the elongate shaft.

30 35. The atherectomy catheter of claim 34, wherein the imaging element is an optical coherence tomography imaging element.

36. An atherectomy catheter comprising:
an elongate catheter body having a fixed jog therein, the fixed jog including a distal inflection point and a proximal inflection point, the inflection points having opposite curvatures;
5 and
a rotatable cutter having a distal cutting edge near the distal end of the elongate body;
wherein a distance from the distal cutting edge to the distal inflection point is less than a distance from the distal inflection point to the proximal inflection point.
- 10 37. The atherectomy catheter of claim 36, wherein an angle of the distal inflection point is between 120 and 180 degrees, and wherein an angle of the proximal inflection point is between 120 and 180 degrees.
38. The atherectomy catheter of claim 36, wherein the angle of the distal inflection point is
15 140 degrees and the angle of the proximal inflection point is 160 degrees.
39. The atherectomy catheter of claim 36, wherein the catheter further includes a nosecone attached to the elongate body, the nosecone having a cutting window therein configured to expose the cutter, and wherein the cutting window is positioned along a same side of the
20 elongate body as a convex portion of the distal inflection point.
40. The atherectomy catheter of claim 39, wherein there is no hinge between the nosecone and the elongate body.
- 25 41. The atherectomy catheter of claim 39, further comprising a hinge between the nosecone and the elongate body configured, when hinged, to expose the cutter.
42. The atherectomy catheter of claim 36, wherein a proximal end of the elongate body and a distal end of the elongate body are offset but substantially parallel to one another.
30
43. The atherectomy catheter of claim 36, wherein the fixed jog includes pre-deflected shaped-set ribbon segments.
44. The atherectomy catheter of claim 36, further comprising an imaging element attached to
35 the cutter.

45. The atherectomy catheter of claim 44, wherein the imaging element is an optical coherence tomography imaging element.

5

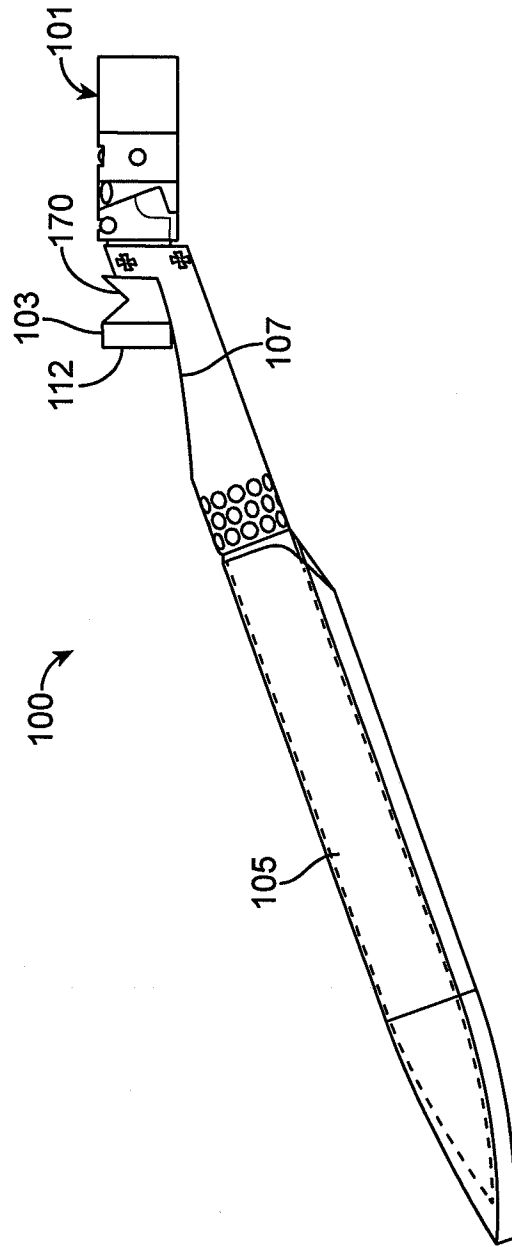

FIG. 1

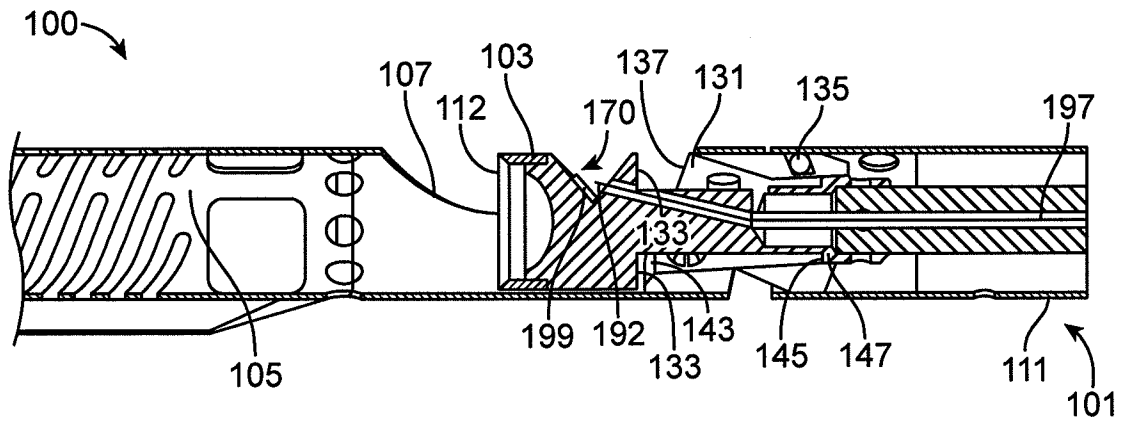

FIG. 2A

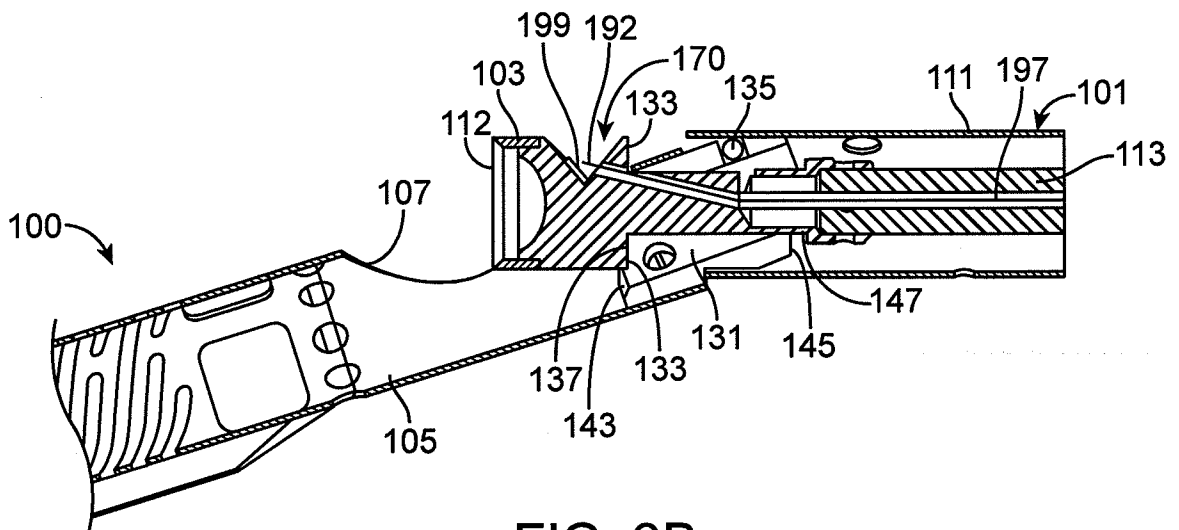

FIG. 2B

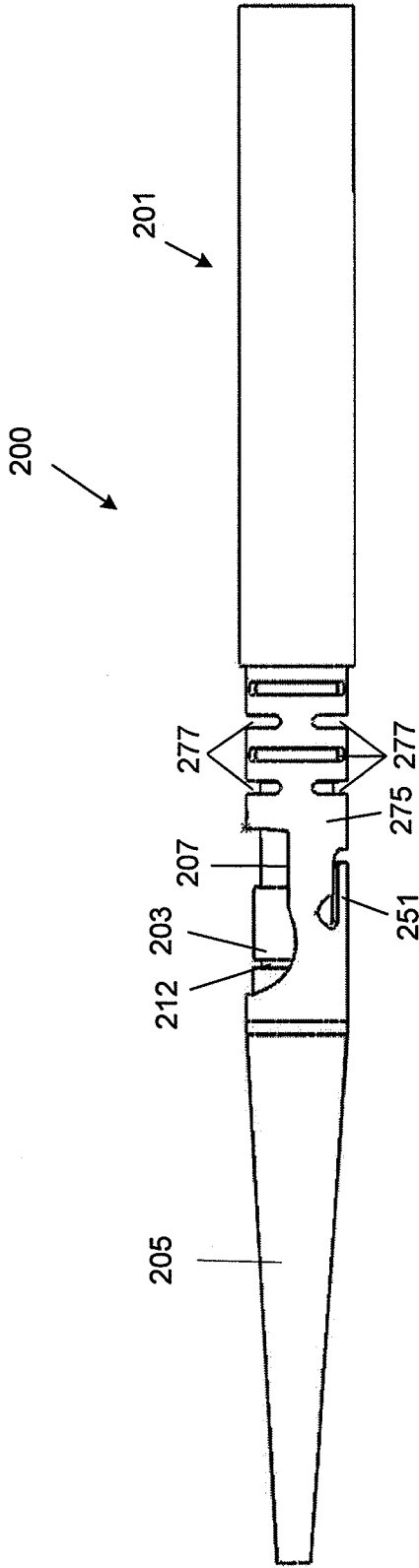

FIG. 3A

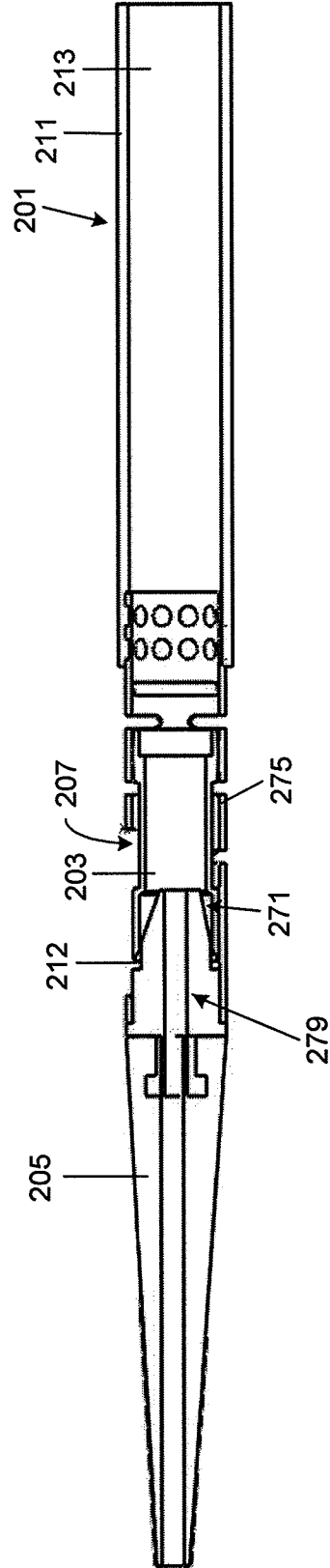

FIG. 3B

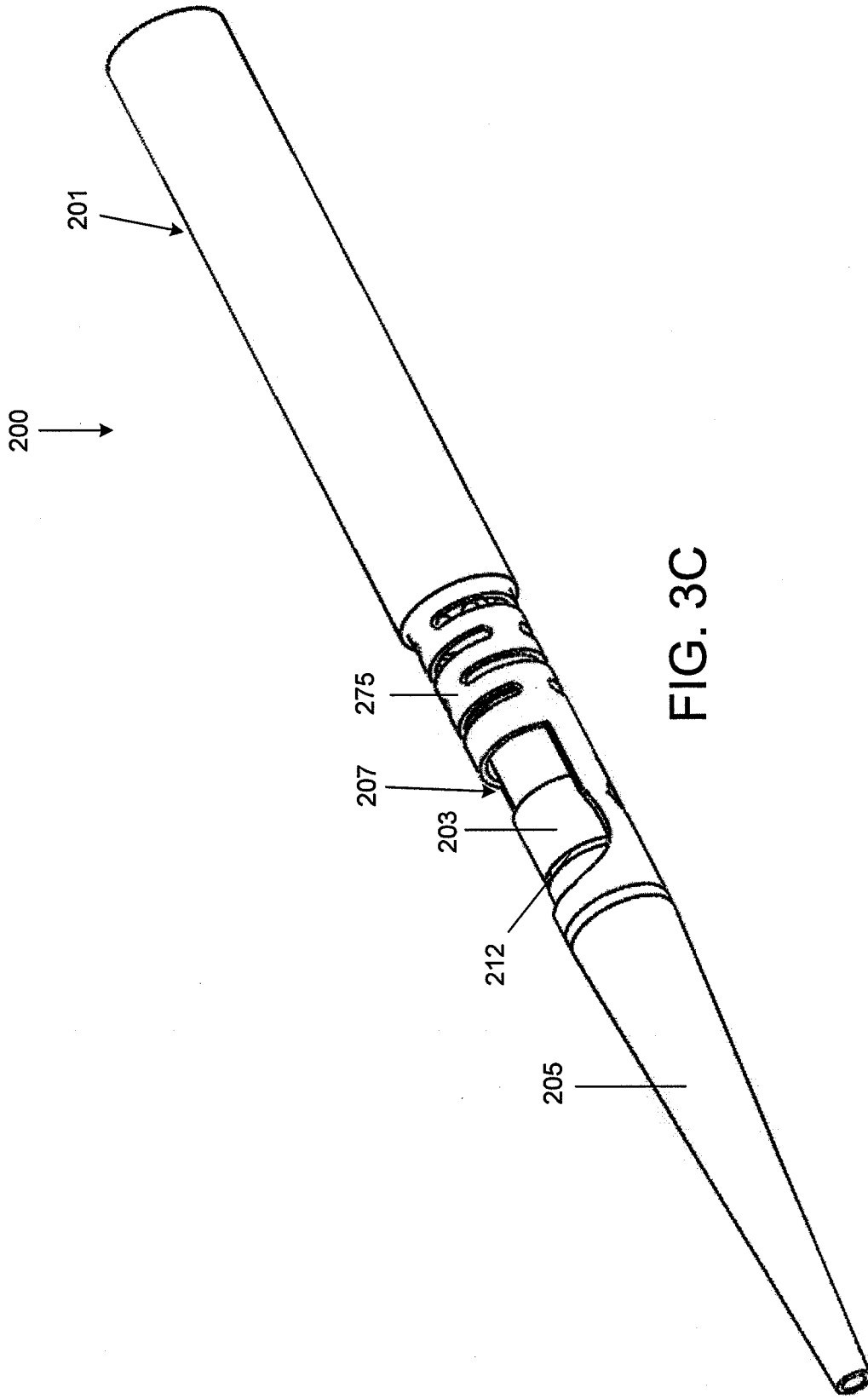
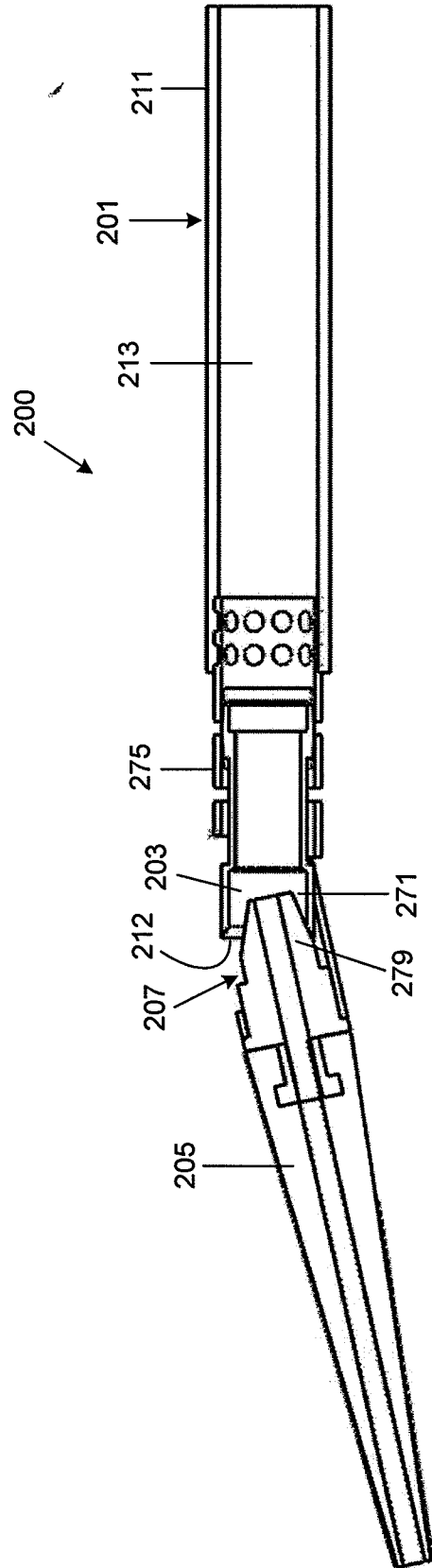
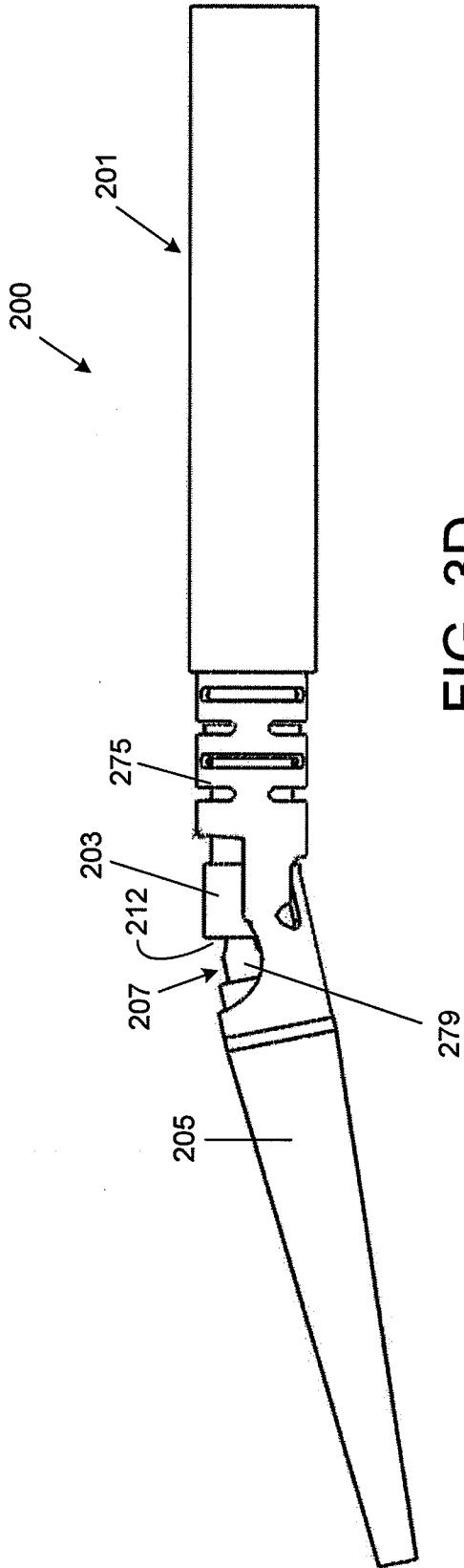

FIG. 3C



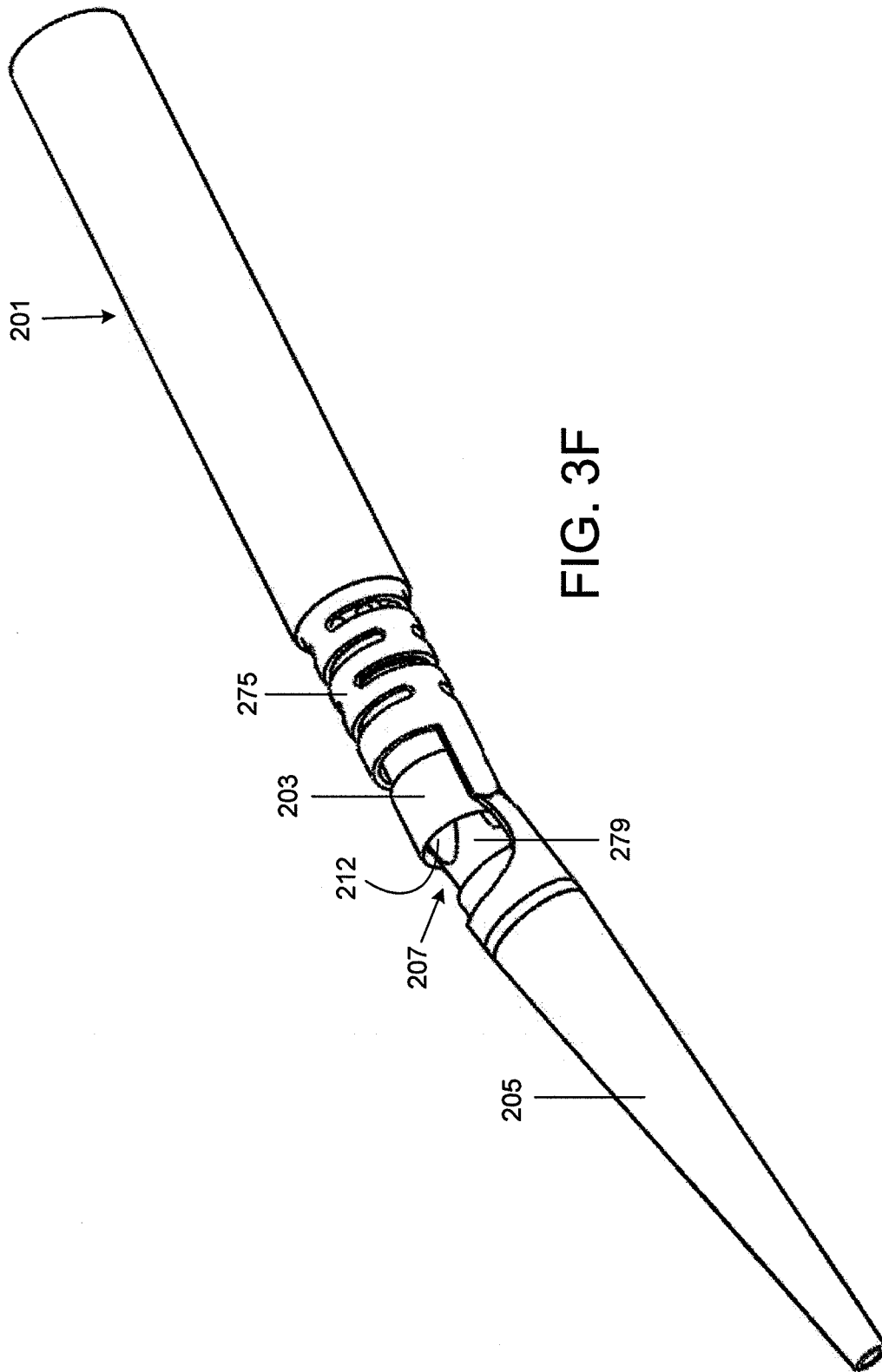

FIG. 3F

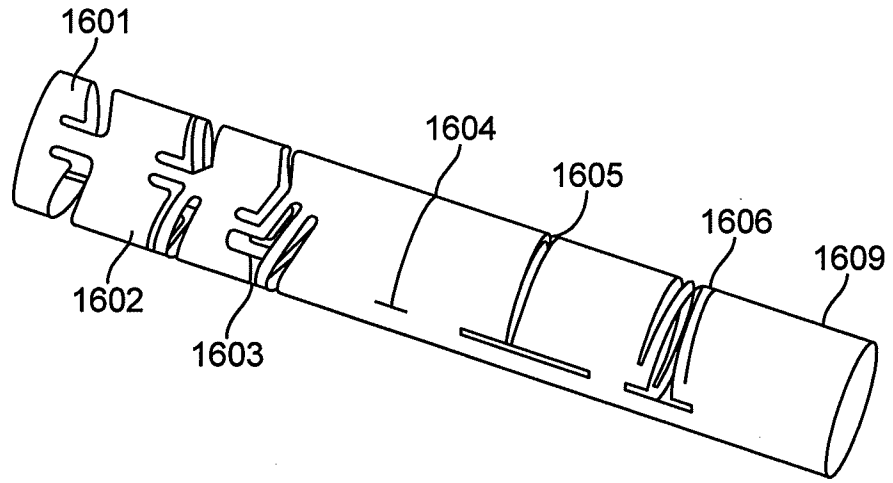

FIG. 4A

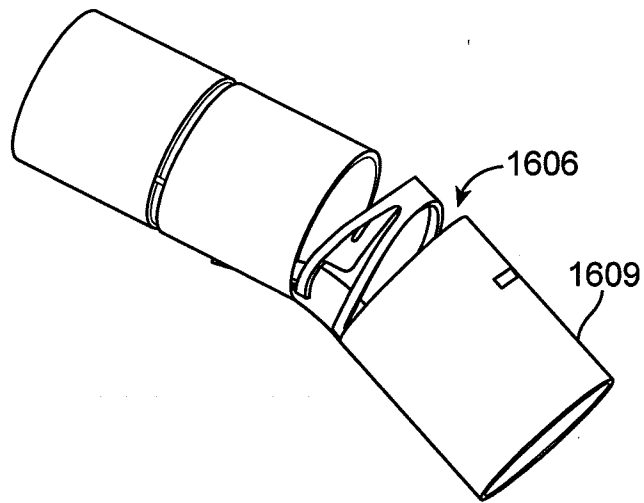
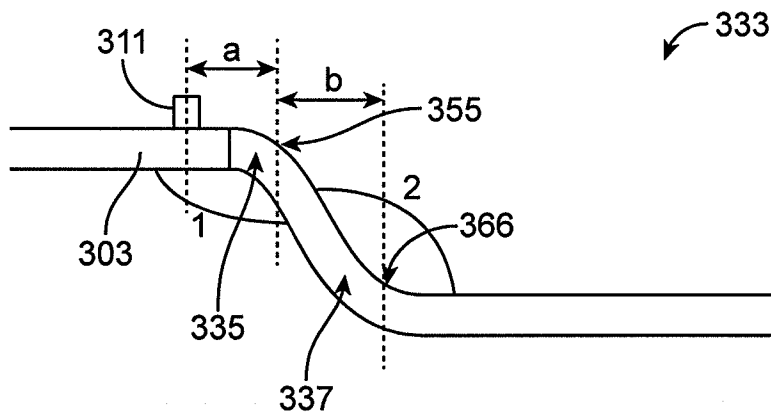
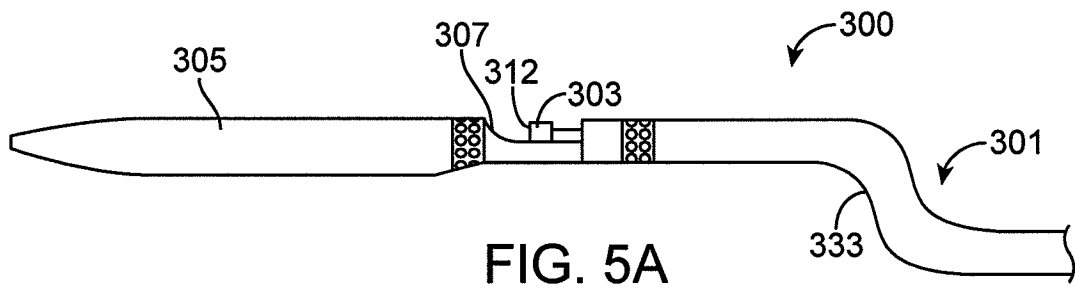

FIG. 4B



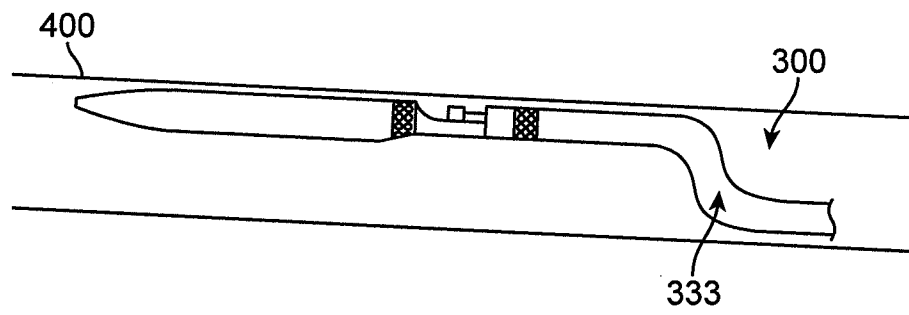

FIG. 6

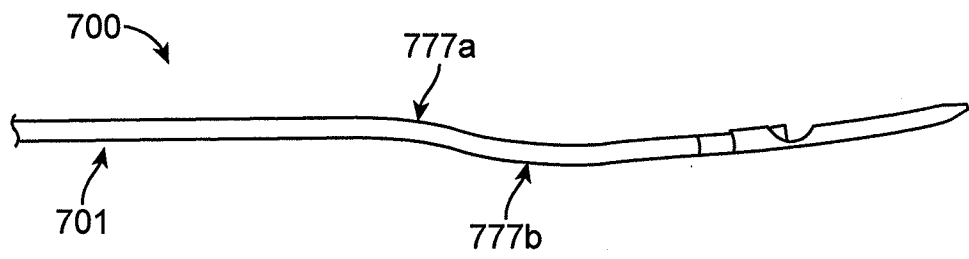

FIG. 7A

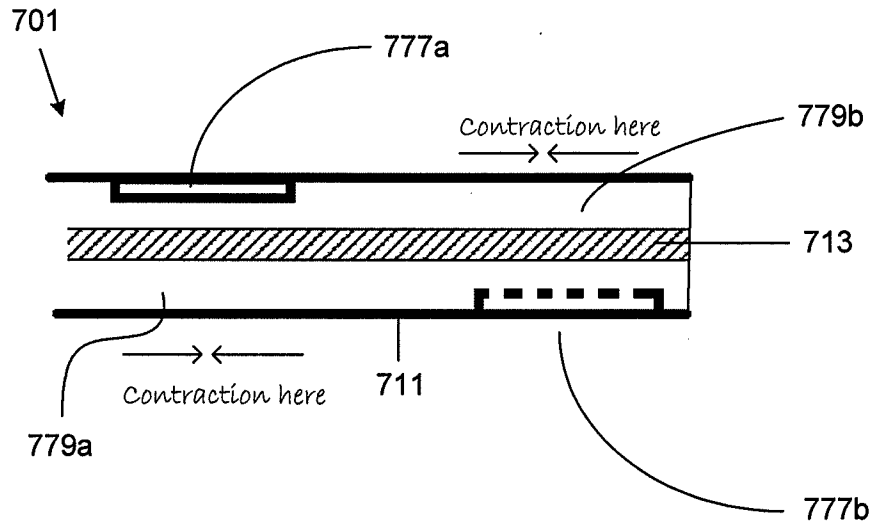

FIG. 7B

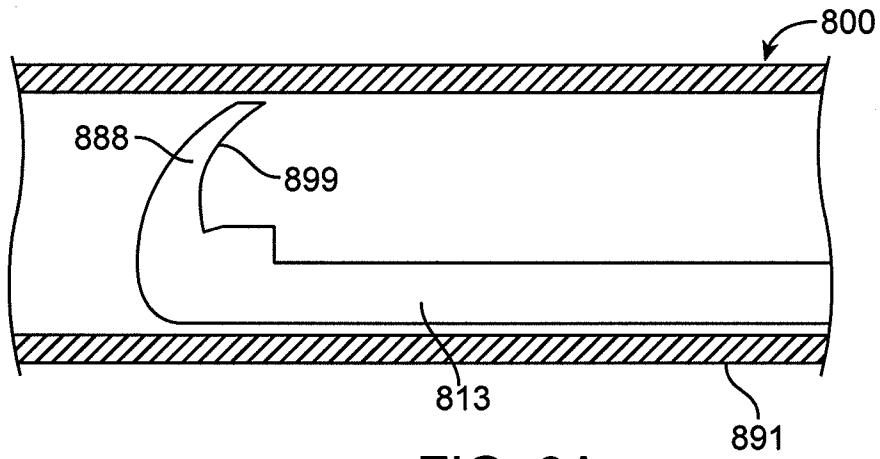

FIG. 8A

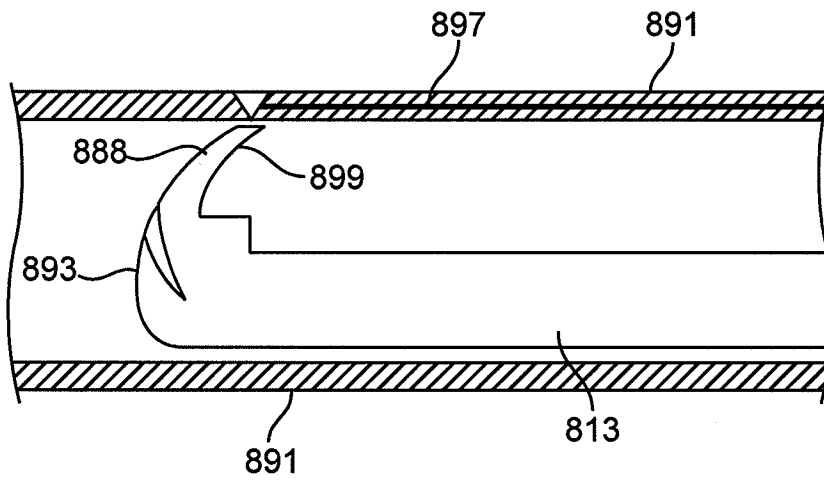

FIG. 8B

A. CLASSIFICATION OF SUBJECT MATTER**A61B 17/3207(2006.01)i, A61B 1/04(2006.01)i, A61M 25/01(2006.01)i**

According to International Patent Classification (IPC) or to both national classification and IPC

B. FIELDS SEARCHED

Minimum documentation searched (classification system followed by classification symbols)

A61B 17/3207; A61B 17/22; A61B 18/24; A61M 29/02; A61B 5/00; A61B 1/04; A61M 25/01

Documentation searched other than minimum documentation to the extent that such documents are included in the fields searched

Korean utility models and applications for utility models

Japanese utility models and applications for utility models

Electronic data base consulted during the international search (name of data base and, where practicable, search terms used)

eKOMPASS(KIPO internal) & Keywords: catheter, atherectomy, debulk, OCT, image, fiber, remove, plaque, vein, alleviate, jog, support

C. DOCUMENTS CONSIDERED TO BE RELEVANT

Category*	Citation of document, with indication, where appropriate, of the relevant passages	Relevant to claim No.
X	US 2012-0046679 A1 (PATEL, N. H. et al.) 23 February 2012 See paragraphs [0037], [0065], [0075], [0079], [0080], [0091], [0113], [0114]; FIGURES 1-2B, 4D-4F, 8A, 8B, 11, 16, 21A, 21B.	1, 7-15, 22-35
A		2-6, 16-21, 36-45
A	US 2010-0241147 A1 (MASCHKE, M.) 23 September 2010 See claims 14-24; FIGURES 1-12.	1-45
A	US 2008-0139897 A1 (AINSWORTH, D. R. et al.) 12 June 2008 See claims 1-13; FIGURE 1B.	1-45
A	US 2010-0049225 A1 (TO, J. et al.) 25 February 2010 See claim 1; FIGURES 1A-1B.	1-45
A	US 2004-0092915 A1 (LAVATTER, I. J.) 13 May 2004 See claim 1; FIGURES 4-6.	1-45

 Further documents are listed in the continuation of Box C. See patent family annex.

* Special categories of cited documents:

"A" document defining the general state of the art which is not considered to be of particular relevance

"E" earlier application or patent but published on or after the international filing date

"L" document which may throw doubts on priority claim(s) or which is cited to establish the publication date of citation or other special reason (as specified)

"O" document referring to an oral disclosure, use, exhibition or other means

"P" document published prior to the international filing date but later than the priority date claimed

"T" later document published after the international filing date or priority date and not in conflict with the application but cited to understand the principle or theory underlying the invention

"X" document of particular relevance; the claimed invention cannot be considered novel or cannot be considered to involve an inventive step when the document is taken alone

"Y" document of particular relevance; the claimed invention cannot be considered to involve an inventive step when the document is combined with one or more other such documents, such combination being obvious to a person skilled in the art

"&" document member of the same patent family

Date of the actual completion of the international search

26 June 2013 (26.06.2013)

Date of mailing of the international search report

26 June 2013 (26.06.2013)

Name and mailing address of the ISA/KR

 Korean Intellectual Property Office
 189 Cheongsa-ro, Seo-gu, Daejeon Metropolitan City,
 302-701, Republic of Korea

Facsimile No. 82-42-472-7140

Authorized officer

HAN, In Ho

Telephone No. 82-42-481-3362



INTERNATIONAL SEARCH REPORT

Information on patent family members

International application No.

PCT/US2013/031901

Patent document cited in search report	Publication date	Patent family member(s)	Publication date
US 2012-0046679 A1	23.02.2012	CA 2803992 A1	05.01.2012
		EP 2588012 A2	08.05.2013
		WO 2012-003430 A2	05.01.2012
		WO 2012-003430 A3	12.04.2012
US 2010-0241147 A1	23.09.2010	DE 102009014489 A1	07.10.2010
		US 8257375 B2	04.09.2012
US 2008-0139897 A1	12.06.2008	US 7329223 B1	12.02.2008
		US 7783338 B2	24.08.2010
US 2010-0049225 A1	25.02.2010	AU 2007-269189 A1	10.01.2008
		AU 2007-269274 A1	10.01.2008
		AU 2008-271034 A1	08.01.2009
		AU 2009-234392 A1	15.10.2009
		CA 2656594 A1	10.01.2008
		CA 2656599 A1	10.01.2008
		CA 2720761 A1	15.10.2009
		CN 101511284 A	19.08.2009
		CN 101511284 B	09.11.2011
		CN 101511285 A	19.08.2009
		CN 101511285 B	18.07.2012
		CN 101795630 A	04.08.2010
		CN 101795630 B	06.03.2013
		CN 102088920 A	08.06.2011
		CN 102088920 B	24.04.2013
		CN 102327139 A	25.01.2012
		EP 2037821 A2	25.03.2009
		EP 2037822 A2	25.03.2009
		EP 2164409 A1	24.03.2010
		EP 2211732 A1	04.08.2010
		EP 2268213 A2	05.01.2011
		JP 2009-542371 A	03.12.2009
		JP 2009-542372 A	03.12.2009
		JP 2010-532211 A	07.10.2010
		JP 2011-517601 A	16.06.2011
		KR 10-1112633 B1	15.02.2012
		KR 10-2009-0037906 A	16.04.2009
		KR 10-2009-0049051 A	15.05.2009
		KR 10-2010-0047854 A	10.05.2010
		KR 10-2011-0005842 A	19.01.2011
		US 2008-0004643 A1	03.01.2008
		US 2008-0004647 A1	03.01.2008
		US 2008-0024381 A1	31.01.2008
		US 2008-0045986 A1	21.02.2008
		US 2009-0018565 A1	15.01.2009
		US 2009-0018566 A1	15.01.2009
US 2009-0018567 A1	15.01.2009		
US 2009-0024085 A1	22.01.2009		

INTERNATIONAL SEARCH REPORT

Information on patent family members

International application No.

PCT/US2013/031901

Patent document cited in search report	Publication date	Patent family member(s)	Publication date
		US 2009-0234378 A1	17.09.2009
		US 2011-0040315 A1	17.02.2011
		US 2011-0112563 A1	12.05.2011
		US 2011-0152906 A1	23.06.2011
		US 2011-0152907 A1	23.06.2011
		US 2013-0085515 A1	04.04.2013
		US 7868836 B2	11.01.2011
		US 8070762 B2	06.12.2011
		US 8236016 B2	07.08.2012
		US 8361094 B2	29.01.2013
		WO 2008-005888 A2	10.01.2008
		WO 2008-005888 A3	06.11.2008
		WO 2008-005891 A2	10.01.2008
		WO 2008-005891 A3	18.12.2008
		WO 2009-005779 A1	08.01.2009
		WO 2009-054968 A1	30.04.2009
		WO 2009-126309 A2	15.10.2009
		WO 2009-126309 A3	21.01.2010
US 2004-0092915 A1	13.05.2004	EP 0542901 A1	26.05.1993
		EP 0542901 B1	25.09.1996
		US 2002-0002370 A1	03.01.2002
		WO 1992-002276 A1	20.02.1992