

May 23, 1961

A. N. PARUOLO
ARTICLE DISPLAY BOARD
Filed Feb. 5, 1958

2,985,315

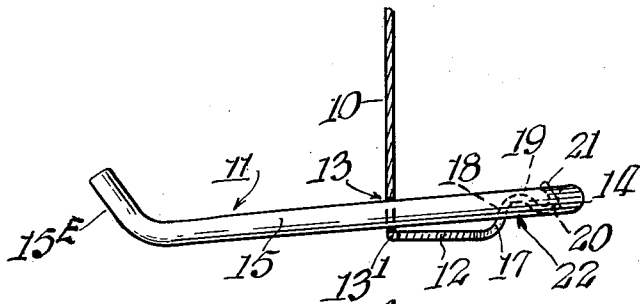
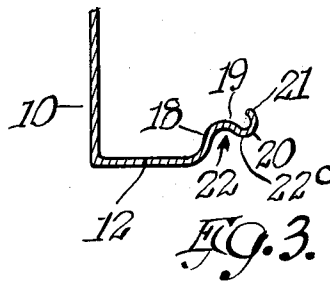
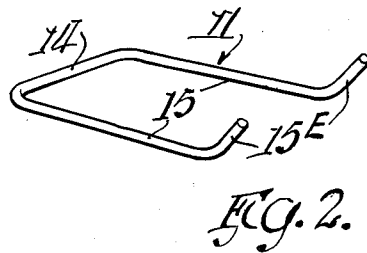
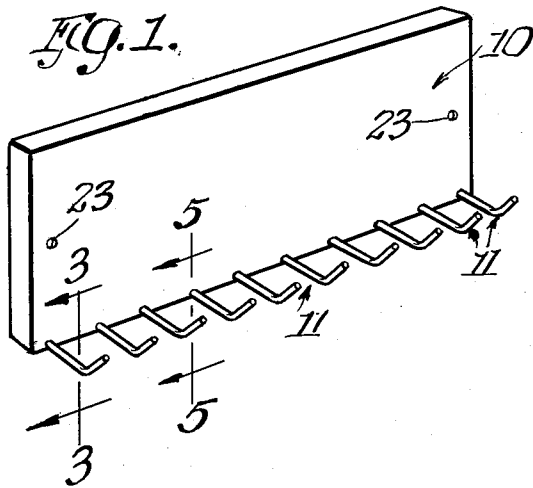

FIG. 4.

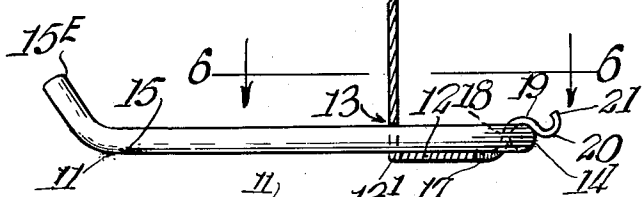

FIG. 5.

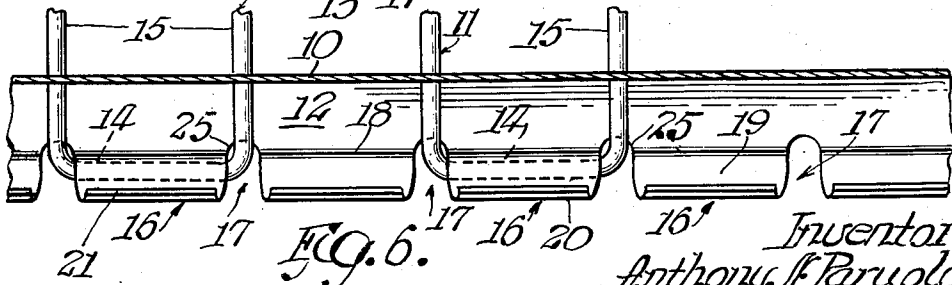

FIG. 6.

Inventor
Anthony S. Paruolo
Olson, Macklenburg, von Holst,
Bundleton & Neuman
Atty's

1

2,985,315

ARTICLE DISPLAY BOARD

Anthony N. Paruolo, Norridge, Ill., assignor to Advertising Metal Display Co., Chicago, Ill., a corporation of Illinois

Filed Feb. 5, 1958, Ser. No. 713,418

4 Claims. (Cl. 211—177)

This invention relates to improvements in display boards, comprising a panel having hangers projecting outwardly therefrom for the purpose of supporting and displaying various items of merchandise, of which fan belts, hose clamps, battery cables are examples.

Display boards of the type heretofore designed for this purpose are open to one or more objections. In certain constructions the board comprises a plurality of separate elements mounted on the rear side of the board and which must be swung into position in order to lock the hanger members in position. Boards of this type are relatively expensive to produce and require the use of some sort of tool in order to permit the assembler to perform the necessary operations.

Other display boards are of such construction that they comprise struck-out tongues, which must be bent up or out of the plane of the metal of the board in order to lock the hanger member in place. In order to perform this operation it is also necessary that the assembler have available and use some sort of a tool, such as a screw driver, a pair of pliers or the like.

One of the objects of the present invention is to provide a display board which can be made of a single sheet of metal of such construction that the hanger members can be firmly locked in place without the use of tools of any kind.

Another object of the invention is to provide a display board of this type which can be made of a single sheet of metal and which shall be of such construction that the hanger members can be firmly locked in operative position without the necessity of manipulating any swingable members or bending struck-out tongues or the like.

Again, it is an object of the invention to provide a display board of this type, which can be made at low cost; which can be shipped in knocked-down condition; which can be assembled quickly and easily and which, when assembled, shall constitute a sturdy structure with the hanger members firmly locked in operative position.

Further objects and advantages of the invention will be better understood by reference to the accompanying drawing illustrating the preferred embodiment of the invention, in which

Fig. 1 is a perspective view of an article display board embodying the invention.

Fig. 2 is a perspective view of one of the hanger members, a number of which are assembled with the display board and locked in position thereon.

Fig. 3 is a fragmentary sectional view on the line 3—3 of Fig. 1, but on an enlarged scale.

Fig. 4 is a sectional view similar to Fig. 3, but illustrating one step or stage of assembling the hanger member of Fig. 2 with other parts of the structure.

Fig. 5 is a view on the line 5—5 of Fig. 1 but on the scale of Fig. 4, showing the hanger member locked in its final position, and

Fig. 6 is a fragmentary, longitudinal, horizontal, sec-

2

tional view on the line 6—6 of Fig. 5, but on a slightly smaller scale.

The article display board is made of a sheet of material 10, preferably sheet metal, provided with a plurality of hangers 11 projecting therefrom for the purpose of displaying articles and from which the articles can be readily removed, when required.

The unit structure or panel 10 has a bottom portion 12 which, as best shown in Figs. 3, 4 and 5, extends rearwardly from the panel 10, the latter having a plurality of spaced openings 13 therein, the lower portions of which are substantially in the plane of the rearwardly extending portion 12. The diameter of the openings 13 is substantially equal to the diameter of the rod stock of which the hangers 11 is made. However, a small portion of the stock 12 is preferably cut away at 13' to facilitate the assembly operation, as will be later explained.

The hanger members, one of which is shown detached from the board in Fig. 2, each comprises a rod, preferably of metal, having a yoke portion 14 and arm portions 15, the outer ends of the latter preferably terminating in upwardly bent portions 15E.

The rearwardly extending bottom portion 12 of the board unit terminates in a plurality of longitudinally spaced sections each of which, as a whole, bears the reference 16, and which are spaced apart by cut-out areas 17 of a width but slightly greater than the diameter of the hanger rod stock so that the latter may be snugly received therein.

Each section 16 comprises a portion 18 upstanding from the rearwardly extending bottom portion 12, a downwardly and rearwardly extending curved portion 19, the latter merging into a reversely curved portion 20 which terminates in a slightly forwardly and upwardly extending cam surface portion 21. There is thus provided a downward and somewhat rearwardly facing channel 22 which extends substantially throughout the length of the display board except for the cut-out areas 17.

The panel member 10 is provided with openings 23 through which screws or the like may be inserted for securing the display board to a wall or other support.

It will be understood that the unit will be shipped in knocked-down condition, i.e. with the hangers 11 separate from the remainder of the unit.

To assemble the hangers with the board unit no tools of any kind are required. It is but necessary to insert the upturned portion 15E of the hanger unit into the openings 13 in the panel portion 10 and to shove the hanger forwardly until the yoke portion 14 of the hanger engages the cam surface 21, as illustrated in Fig. 4. By pressing downwardly and then forwardly on the yoke portion 14 of the hanger, the hanger can be readily "sprung" into the position illustrated in Fig. 5, wherein the yoke portion of the hanger is disposed in the channel 22, the hanger being thereby held in place against movement in any direction by any normal forces tending to displace it. It should be stated that the cutaway at 13' aids in receiving the upturned ends 15E of the hanger when the hanger is started through the openings 13, at which time the hanger as a whole will extend upwardly and rearwardly.

It will be understood that articles hung upon the arm portions 15 of the hangers that extend forwardly from the panel, tend to swing the yoke portions 14 of the hangers upwardly. However, such action only tends more firmly to lock the hangers in the channel 22. Since substantially the entire length of the yoke portion 14 of each hanger is embraced by the metal forming the channel 22, the sheet material can be relatively thin stock and still afford ample strength.

3

The portions 25 defining edges of the cut-outs 17 are located within corners of the U-shaped hanger members and thus prevent any undue movement of the hanger members longitudinally of the board panel.

The upstanding curved and reversely curved portions at the rear bottom of the board unit, in addition to serving as cam surfaces and hanger locking means, also add greatly to the rigidity and stability of the unit as a whole and are factors permitting the use of relatively thin sheet stock that will, at the same time, provide adequate strength with suitable spring action to enable easy safe assembly of the hangers with the board unit. These factors enable production at a relatively low cost.

It will be seen from the foregoing that there are no separate parts on the board which must be swung into position to lock the hanger members in place and which require the use of tools, nor are there cut-out tongues which the assembler must bend into locking position and which require the use of tools of some sort.

If, for any reason, it should be desired to disassemble the device after assembly, this can be done. To remove a hanger it is only necessary to press rearwardly on the outer ends of the hanger arms. When so doing, the surface 22C of the channel 22 acts as a cam surface to force the yoke portion 14 of the hanger downwardly with perhaps some upward springing of the reversely curved terminal portion 20 until the yoke portion is free, at which time the yoke portion can be moved upwardly to the position substantially as shown in Fig. 4, and complete separation effected by rearward withdrawal of the hanger as a whole.

It will, of course, be understood that display boards may be made in various sizes and with any desired number of hangers, the one shown in the drawings being by way of illustration and not by way of limitation.

I claim:

1. A display board having hangers projecting from the front side thereof and adapted to be packaged in dismantled condition and to be assembled without the use of tools, a panel member formed of sheet metal stock having a bottom portion extending rearwardly from the bottom edge thereof, the longitudinal rear margin of said bottom portion being formed into an elongated first portion extending upwardly adjacent the rear marginal part thereof, said first portion merging into a second portion which extends downwardly and rearwardly therefrom, said first and second portions forming a generally downwardly facing elongated channel spaced forwardly of the longitudinal rear margin, said panel member being provided with a plurality of spaced rod-receiving openings adjacent the lower margin thereof, and a U-shaped hanger for each pair of said rod-receiving openings, with the side arms of the U-shaped hanger extending at right angles from opposite ends of the yoke portion, the side arms of said U-shaped hanger rods being insertable through a pair of said rod-receiving openings, the terminal margins of said rearwardly extending

4

bottom portion of the panel being cut away in a forward direction so that by downward and forward pressure on the yoke portion of the hanger, the same is caused to lodge in the channel formed by said first and second portions, and portions of the hanger between the side arms and the yoke are accommodated in said cutaway areas, thereby operatively securing the hanger in place.

2. The arrangement set forth in claim 1 in which the said first portion extends rearwardly as well as upwardly.

3. The arrangement set forth in claim 1 in which a part of the bottom portion is cut away in the vertical plane of the panel member to facilitate assembly of the hanger with the display board.

4. A display board having hangers projecting from the front side thereof and adapted to be packaged in dismantled condition and to be assembled without the use of tools, a panel member formed of sheet metal stock having a bottom portion extending rearwardly from the bottom edge thereof, the longitudinal rear margin of said bottom portion being formed into an elongated first portion extending upwardly adjacent the rear marginal part, said first portion merging into a second portion which extends downwardly and rearwardly therefrom, said first and second portions forming a generally downwardly facing elongated channel spaced forwardly of the longitudinal rear margin, a third portion merging with said second portion, said third portion being reversely bent to extend upwardly and forwardly, thereby providing a cam surface for engagement by a portion of the hanger rod in the assembly operation, said panel member being provided with a plurality of spaced rod-receiving openings adjacent the lower margin thereof, and a U-shaped hanger for each pair of said rod-receiving openings, with the side arms of the U-shaped hanger extending at right angles from opposite ends of the yoke portion, the side arms of said U-shaped hanger rods being insertable through a pair of said rod-receiving openings the terminal margins of said rearwardly extending bottom portion of the panel being cut away in a forward direction so that by downward and forward pressure on the yoke portion of the hanger, the yoke portion is caused to engage the cam surface of said third portion, thereby facilitating the lodging of the yoke portion in the channel formed by said first and second portions, and portions of the hanger between the side arms and the yoke are accommodated in said cutaway areas, whereby the hanger is operatively secured in place.

References Cited in the file of this patent

UNITED STATES PATENTS

1,732,162	Griner	Oct. 15, 1929
2,723,432	Flora	Nov. 15, 1955
2,730,243	Platt	Jan. 10, 1956

FOREIGN PATENTS

500,244	Canada	Mar. 2, 1954
---------	--------	--------------