

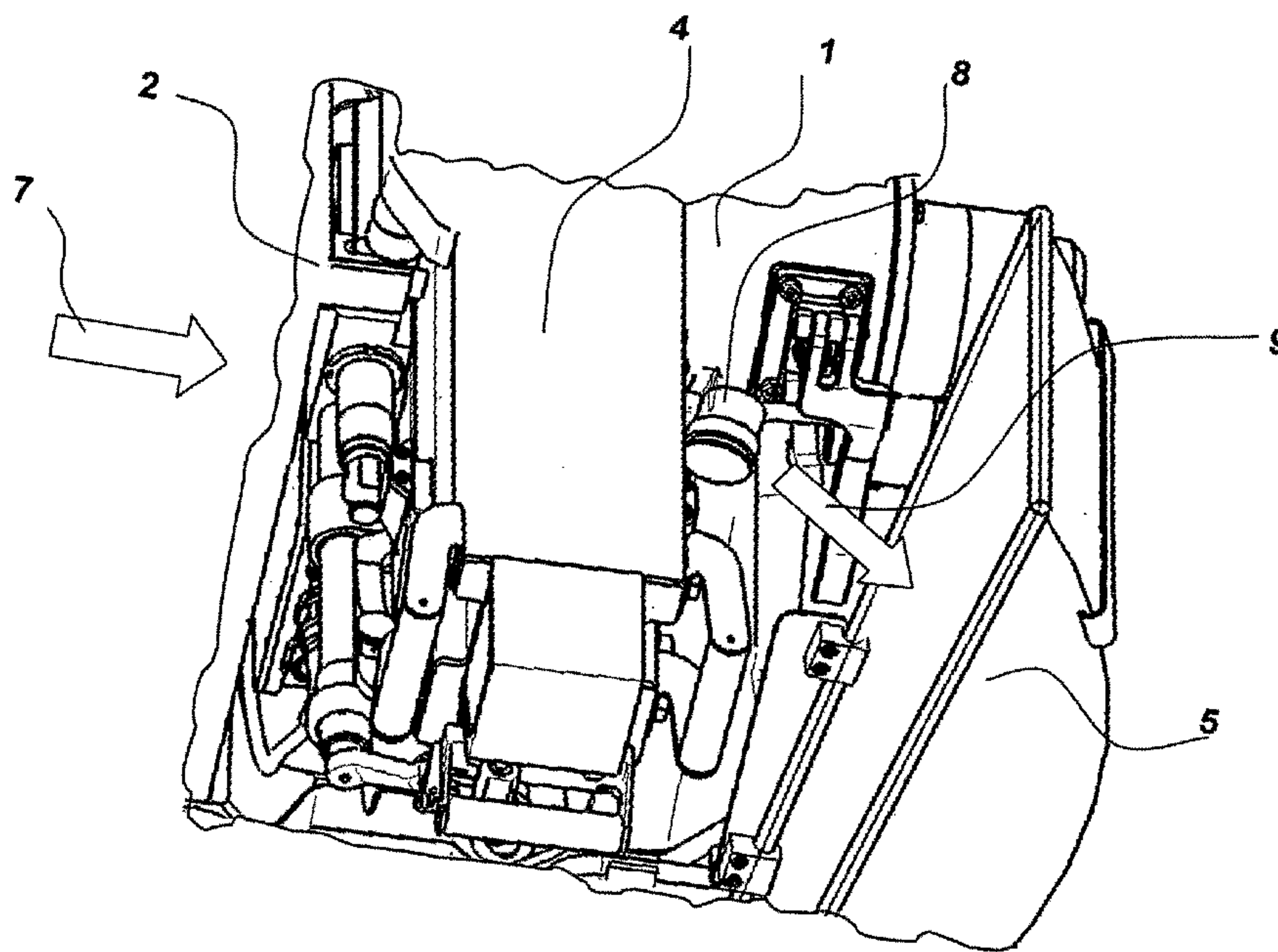

(86) Date de dépôt PCT/PCT Filing Date: 2010/10/12  
 (87) Date publication PCT/PCT Publication Date: 2011/05/05  
 (45) Date de délivrance/Issue Date: 2017/08/01  
 (85) Entrée phase nationale/National Entry: 2012/03/20  
 (86) N° demande PCT/PCT Application No.: EP 2010/006231  
 (87) N° publication PCT/PCT Publication No.: 2011/050905  
 (30) Priorité/Priority: 2009/10/28 (DE10 2009 051 064.8)

(51) Cl.Int./Int.Cl. *F41A 9/60* (2006.01)  
 (72) Inventeur/Inventor:  
 BRUHN, RALF, DE  
 (73) Propriétaire/Owner:  
 RHEINMETALL LANDSYSTEME GMBH, DE  
 (74) Agent: FETHERSTONHAUGH & CO.

(54) Titre : DISPOSITIF DE COLLECTE EN PARTICULIER POUR DOUILLES DE MUNITIONS ET/OU MAILLONS  
 (54) Title: CATCHING DEVICE FOR AMMUNITION SHELLS AND/OR CONNECTORS



(57) Abrégé/Abstract:

The invention relates to a catching device (5) and a collecting receptacle (3) cooperating therewith, to be attached laterally to a weapon station (1), for example. In a preferred embodiment, the collecting receptacle (3) is arranged separately and either adjacent to or behind the weapon station (1). After firing, the empty shell and/or the belt links and/or connector elements (8) are guided toward the lateral catching device and from there into the collecting receptacle (3). Due to the special design of the catching device, the guidance is preferably done by sliding the parts (8) along the rear wall (5.3) of the device (5).

**Abstract**

The invention relates to a catching device (5) and a collecting receptacle (3) cooperating therewith, to be attached laterally to a weapon station (1), for example. In a preferred embodiment, the collecting receptacle (3) is arranged separately and either adjacent to or behind the weapon station (1). After firing, the empty shell and/or the belt links and/or connector elements (8) are guided toward the lateral catching device and from there into the collecting receptacle (3). Due to the special design of the catching device, the guidance is preferably done by sliding the parts (8) along the rear wall (5.3) of the device (5).

## DESCRIPTION

### CATCHING DEVICE FOR AMMUNITION SHELLS AND/OR CONNECTORS

The present invention relates to a catching and collecting device for ammunition shells and to the associated connector elements of the catching device in weapon stations, in particular weapon stations that have a mounted weapon.

Military vehicles are used increasingly with weapon stations for self-defense and for engaging enemy targets. The weapon stations enable the operator to observe and engage target objects under armored protection. Generally, such weapon stations are mechanical / electrical or remote control in design. Remote controlled weapon stations are also referred to as Remote Weapon Station (RWS) or Remote Controlled Weapon Station (RCWS).

Weapon stations are increasingly armed with military weapons, such weapons having generally been being designed for manual use and as such are handled and operated directly by soldiers. To adapt these weapons to, or mount them on the weapon stations, the former are expanded using special adapters and fittings and thus rendered remote controllable. Such weapons, for example, machine guns (MG) or grenade launchers (GMK or AGL) have specialized ammunition feeds and shell / connectors (belt link) – ejection ports. Generally, weapon stations are equipped with ammunition containers which accommodate the ammunition belts with the ammunition and, where desired, frequently have collector receptacles for receiving the empty shells / connectors.

CA 2 200 922 C proposes a collector receptacle for empty shells on the side of a portable fire arm. DE 102 37 688 B4 describes a shell and belt link collector device provided preferably for a machine gun mounted on a gun carriage, wherein a cartridge case channel is screwed to the

gun carriage and the belt link channel is moveable about a pivot. A bag for cartridge cases is mounted on the cartridge case channel which receives both the cartridges and the belt links.

However, for mountable weapons it is difficult, if not impossible to connect such devices to a weapon station, in order to prevent empty shells, etc. from lying strewn about on the vehicle deck and, for example, blocking the vehicle hatches or from being strewn about the shooting periphery.

Weapon stations that have large stores of ammunition and weapons with a high elevation range (weapon – elevation) use open collector receptacles to avoid obstruction of the weapon due to jammed shells. Such collector devices are frequently arranged underneath the weapon ejection port. The collector devices arranged beneath the weapon station receive the majority of shells when the ammunition is ejected downwardly.

CH 526 086 A discloses a gun mount for an automatic firearm which has an ejection port for empty cartridge shells at the rear which are diverted by a guide plate into a receptacle. To ensure that the shells reach the container regardless of the elevation of the weapon, a second guide plate is attached, whereby the first guide plate is pivotally attached in the area at the rear edge and the second guide plate is attached in the area of the front edge of the ejection port, on the elevatable portion thereof, and both are guided as a single fixed part as the weapon is elevated.

From DE 102 07 233 A1 it is known to connect a shell catch holder at the rear of large caliber weapons, which holder, once the shot has been fired and the breach opened, receives the empty shells of the respective ammunition ejected from the rear out of the weapon barrel.

31067-12

3

The object of the present invention is to show a catching device, which ideally also catches laterally ejected parts, such as shells and / or connector elements / belt links, even in the case of an elevatable weapon, and guides them into a receptacle.

The present invention is based on the concept of attaching a catching device and a  
5 collecting receptacle cooperating therewith, for example, laterally to a weapon station. In this arrangement, the collecting receptacle may, in a particular embodiment, form part of the catching device. In the preferred embodiment the collecting receptacle is arranged separately and either adjacent to or behind the weapon station. Alternatively,  
10 it is feasible to attach the collecting receptacle around the entire circumference of the weapon station. After firing, the empty shells and/or the belt links / connector elements are guided toward the lateral catching device and from there into the collecting receptacle. Due to the special design of the catching device, the guidance is preferably done by sliding the parts along the rear wall of the device.

The proposed concept may also be used in weapon systems in which, after the  
15 ammunition is fired, the belt links must still be separated from one another since they do not separate by themselves and the belt links remain connected by hooks and loops. In such case it is possible to attach a belt link separation device in front of the catching device. A separating device of this type is described in EP 1 985 960 A1. Another separating device is also shown in the not previously published  
20 DE 10 2009 031 286.2 of the applicant. The separating device includes both a lower and upper guide, wherein the lower guide is aligned to the width of the connecting site, that is, to the width of the hooks and loops, and is formed by two tongue-like runners or the like. The upper guide is comprised preferably of a spring into which a control cam is connected for guiding the belt link being separated. The width of the spring is  
25 preferably identical to the width of the hooks and loops. In a preferred embodiment, the former is attached behind the ejection device also shown in the not previously published DE 10 2009 031 285.4 of the applicant, which ejection device in turn casts the separate belt links into a catching device not further specified herein.

31067-12

4

Attachment to the weapon station is accomplished preferably by so-called quick release fasteners, etc. thus making it possible to simply and quickly mount or remove in particular the catching device. It is understood that the collecting receptacle as well can be attached to the weapon station by means of quick release fasteners. In this way, it is possible to remove the catching device and the receptacle from, or attach it to, the weapon station using these quick connecting means – depending on client demand or particular use. Selecting lighter materials minimizes additional of weight while providing optimal performance. An additional advantage of this design is that it can be adapted to the respective type of weapon, caliber and type of ejector since it is not limited to being attached from the side.

In some embodiments of the present invention, there is provided a catching device for shells and / connector elements on a mountable and elevatable weapon station, comprising a substantially U-shaped frame having two side sections and an intermediate section as a rear wall of the catching device, by means of which the shells / connector elements are guided into a collecting device, wherein the catching device is attached to a lateral ejection port of the weapon station and to a rear ejection port of the weapon station, the collecting device can be attached at the rear end, on the side or about the entire circumference of the weapon station, and the catching device and the collecting device are adapted to the weapon station by means of quick release fasteners.

The present invention will be described in greater detail below with reference to an exemplary embodiment and the drawings. In the drawings:

Fig. 1 is a rear view of an elevatable weapon station,

Fig. 2 is the ammunition flow in the weapon station shown in Fig. 1.

Fig. 1 shows a weapon station 1 equipped with an ammunition container 2 indicated for stocking ammunition (not shown in detail) for a weapon, for example, a mounted machine gun. The weapon 4 is arranged on or supported in the weapon station 1 and

31067-12

4a

is capable of being elevated to compensate ballistically for the firing distance. It is understood that the weapon 4 is also adjustable with respect to the azimuth. When elevated, the relative position of the weapon 4 is known to change, however, as is the entry and exit of the ammunition of the weapon station 1.

For this reason, catching device (-means) 5 is added to the weapon station 1, being fixed to the weapon station 1 by means of fasteners 6. The catching device 5 diverts the ejected parts into a preferably separate collecting receptacle 3. The fasteners are preferably in the form of quick release fasteners.

The catching device 5 is comprised of a substantially U-shaped frame 5.1 with two side sections 5.2 and an intermediate section 5.3, preferably half-rounded in design. This intermediate section 5.3 constitutes a rear wall for the catching device. To save weight, provision is made in a preferred embodiment for a type of covering for the intermediate section 5.3 disposed between the two outer sections 5.2 of the frame 5.1, such that the rear wall is defined by the covering. For coverings it is possible to use durable fabric, leather, fibers, etc.

The catching device 5 is of a plastic and/or metal construction, preferably in the form of a frame, wherein a covering of the side sections 5.2 using durable fabric, leather, fibers, etc. is also contemplated. However, sections 5.1 to 5.3 constructed completely of plastic and/or metal are also conceivable.

A lateral covering of plastic or metal construction can be omitted, however, if the half-rounded intermediate section 5.3 is small in shape (smaller radius), thereby making it impossible for the parts being collected to slide out between the side sections 5.2.

A collecting receptacle 3 is preferably attached to the rear end of the weapon station 1 and thereby connected to said station, such that the collecting receptacle 3 can be carried along in azimuth when the weapon station 1 is rotated. Though structurally more complex, it is possible to attach the receptacle so that it surrounds the weapon station 1 on all sides, and is designed as a fixed part of a vehicle roof or an object (not further shown), on which the weapon station 1 is mounted.

Fig. 2 shows by way of arrow 7 the flow of ammunition not further detailed herein. The weapon 4 draws the ammunition in a manner known in the art, fires the projectile (not shown in detail) and conveys the shell / connector 8 in the direction 9 out of the weapon 4. The catching device 5 catches the former and conveys it, preferably by guiding it off or downwardly, into the collecting receptacle 3.

31067-12

7

CLAIMS:

1. Catching device for shells and / connector elements on a mountable and elevatable weapon station, comprising
  - a substantially U-shaped frame having two side sections and
  - 5 • an intermediate section as a rear wall of the catching device, by means of which the shells / connector elements are guided into a collecting device, wherein
    - the catching device is attached to a lateral ejection port of the weapon station and to a rear ejection port of the weapon station,
    - the collecting device can be attached at the rear end, on the side or
    - 10 about the entire circumference of the weapon station, and
    - the catching device and the collecting device are adapted to the weapon station by means of quick release fasteners.
2. Catching device according to claim 1, wherein the collecting device is part of the catching device or represents a separate device.
- 15 3. Catching device according to claim 1 or 2, wherein it comprises a frame of plastic and / or metal construction which is partially or completely covered with one or more of durable fabric, leather, and fibers.
4. Catching device according to any one of claims 1 to 3, wherein parts of the catching device are constructed completely of plastic and/or metal.
- 20 5. Catching device according to any one of claims 1 to 4, wherein said device is adapted to a respective type of weapon, caliber and ejection port.
6. Catching device according to any one of claims 1 to 5, wherein the intermediate section is half-rounded in design.

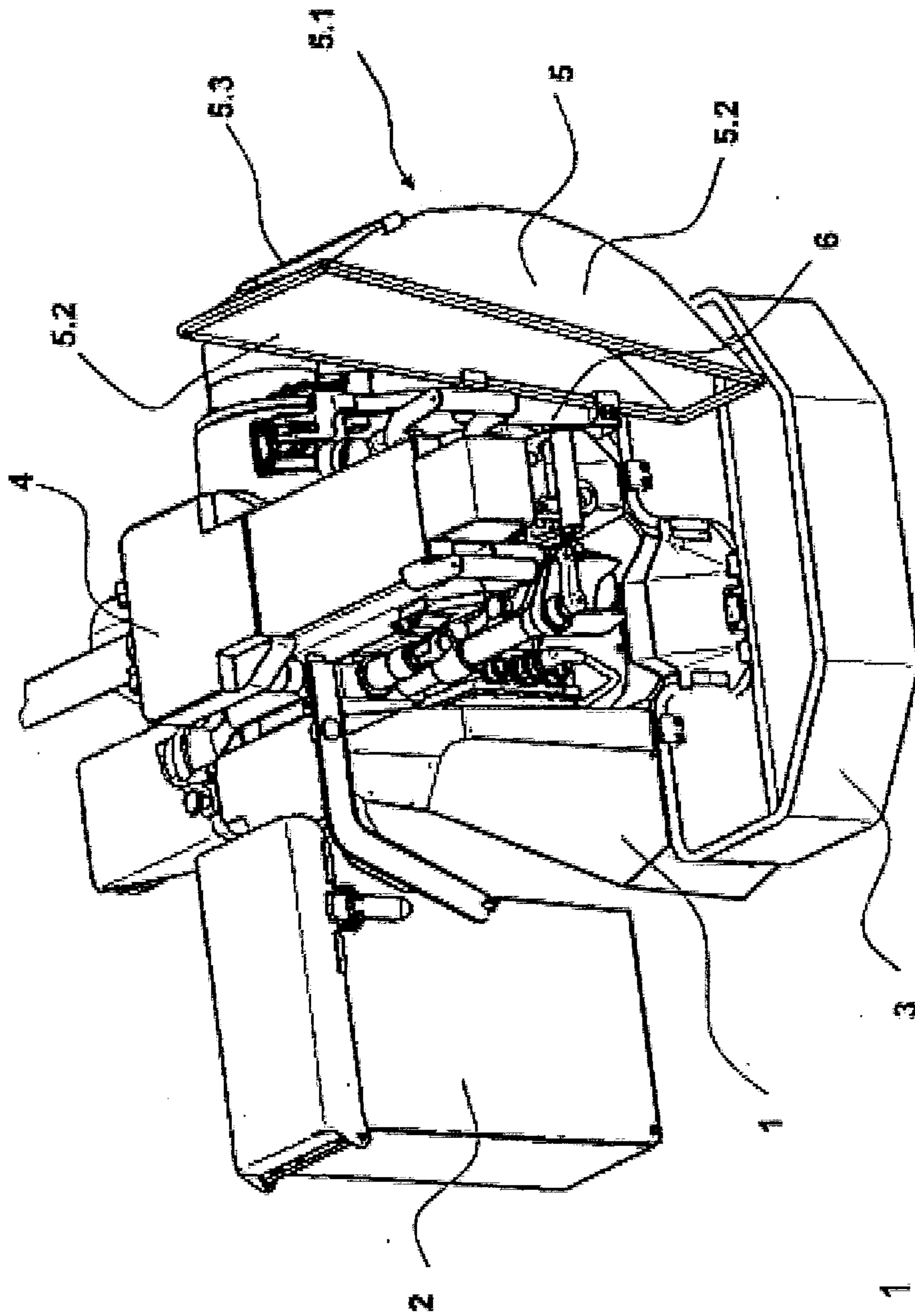

Fig. 1

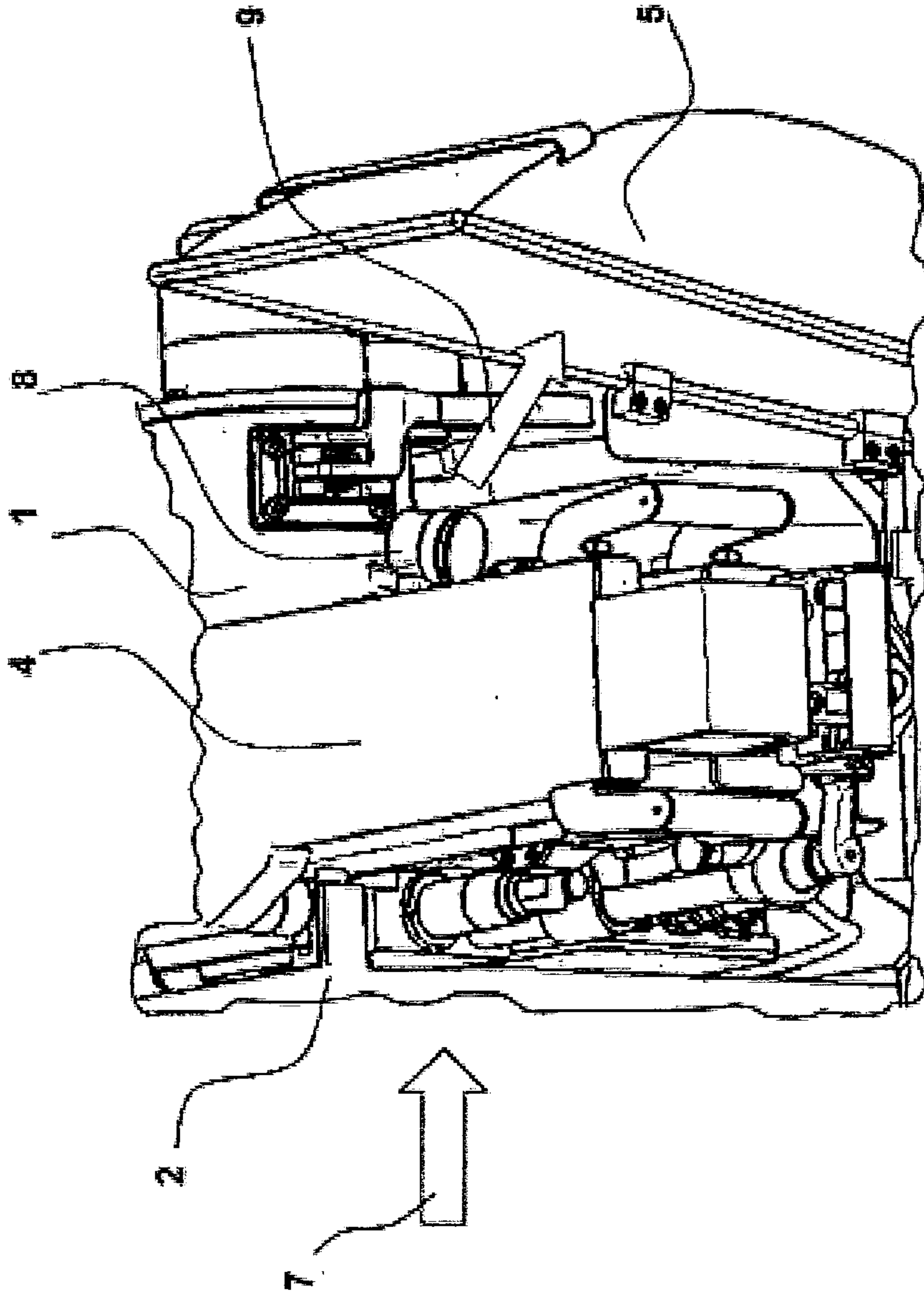

Fig. 2

