

Aug. 3, 1965

F. PLASSER ETAL

3,198,135

MOVABLE APPARATUS USEFUL IN TRACK GRADING

Filed March 12, 1962

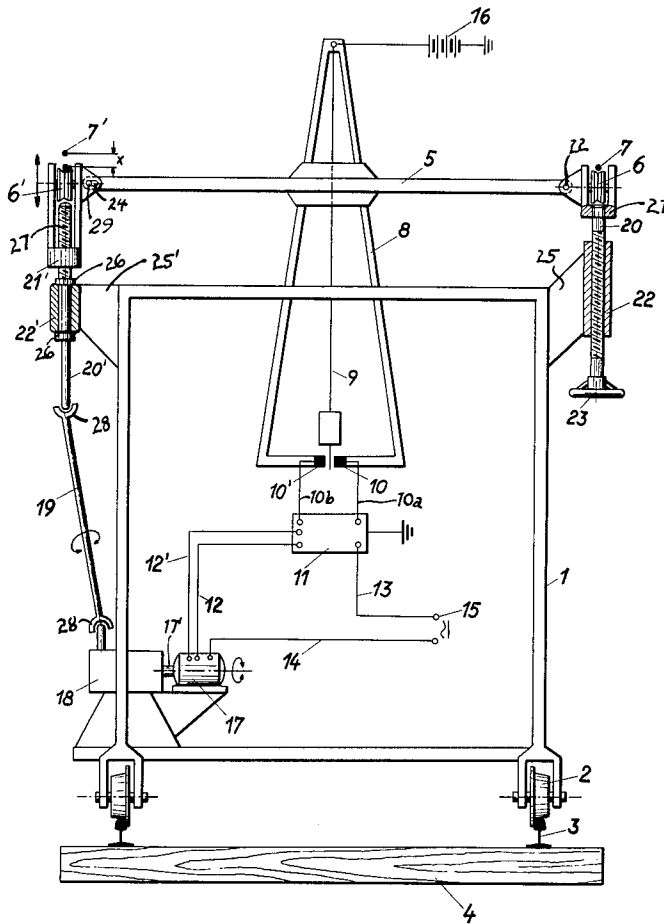

INVENTORS.  
FRANZ PLASSER  
JOSEF THEUER  
BY  
Kurt Kelman  
AGENT

1

2

3,198,135  
**MOVABLE APPARATUS USEFUL IN  
 TRACK GRADING**

Franz Plasser and Josef Theurer, both of  
 Johannesgasse 3, Vienna I, Austria  
 Filed Mar. 12, 1962, Ser. No. 180,065  
 Claims priority, application Austria, Mar. 15, 1961,  
 A 2,179/61  
 5 Claims. (Cl. 104—7)

The present invention relates to track grading apparatus, and more particularly to a bogie movable on the track rails and supporting two reference lines in relation to which the rails are leveled.

Apparatus of this type is generally known and usually is positioned ahead of track grading machinery, the two reference lines extending from a previously graded track section to the bogie where the front ends of the reference lines are anchored and the bogie being positioned on a track section to be graded. In such apparatus, it is necessary to contact or support the reference lines vertically adjustably so that the reference lines may be brought into a desired relative position and the rails may be leveled parallel to this position in the desired grade. It has been customary to assign an operator to such bogies and to move the same manually. This operator also made the necessary vertical adjustment of the reference line supports manually.

In a more recent development in the automation of track maintenance and repair operations, it has been proposed to use self-propelled bogies for this purpose to eliminate the need for a special operator. In this system, the front bogie is held at a predetermined constant or variable distance from the track grading machine by means of the tensioned reference wire or any other elongated flexible element provided for this purpose, as more particularly disclosed and claimed in U.S. patent application Serial No. 93,082, filed Mar. 3, 1961, of which we are two of the joint inventors.

In front bogies of the above type, it was possible to adjust the reference wire support vertically into any desired position to correspond to the desired grade of the associated rail so that the rail may be leveled. However, when such a vertical adjustment of one reference wire was effected, the vertical position of the other reference wire in relation to the adjusted wire was incorrect when the ungraded track section on which the front bogie was positioned had an undesirable horizontal inclination. Therefore, unless the vertical position of the other wire was corrected, too, the track would be leveled with the same transverse inclination as the ungraded track.

It is the primary object of the present invention to provide for the automatic vertical adjustment of the other wire in response to the relative vertical position of the wires whereby such correction may be effected without intervention of an operator.

This object is accomplished in accordance with this invention by providing a mechanical drive means for vertically adjusting the contacting or supporting means for the other wire or reference line. An indicating means, preferably a pendulum, is provided on the bogie for indicating the relative vertical position of the reference lines and the mechanical drive means is actuated by control means operating in response to this relative vertical position indicating means.

In one embodiment of the invention, the control means includes electrical contacts mounted adjacent respective sides of the pendulum in a plane transverse to the track. An electric control circuit is connected to the contacts and actuates the mechanical drive means in a selected

vertical direction depending on which of the contacts is contacted by the pendulum.

With this automatic adjustment of the one reference line in relation to the other one, both reference lines define at all times a desired reference plane vertically spaced from the track plane and in relation to which the track is graded until its plane is parallel to the reference plane, the ends of the reference lines remote from the front bogie being anchored in a previously graded track section so that they obviously define the proper reference.

The above and other objects, features and advantages of the present invention will be more fully understood when considered in the light of the following detailed description of one preferred embodiment taken in conjunction with the accompanying drawing showing a front view, partly in section, of an apparatus built in accordance with the concepts of this invention.

As shown, the apparatus is embodied in a front bogie used in track grading operations wherein the rails are leveled in relation to two reference lines, such as tensioned elongated flexible elements, for instance wires, which define vertical planes with respective ones of the track rails 3 which are mounted on ties 4. The frame 1 of the bogie is mounted on wheels 2 which constitute means arranged for engagement with, and movable on, the track rails 3.

Track correction systems using such apparatus have been disclosed, for instance, in U.S. Patents Nos. 2,974,607 and 2,962,979 as well as in our U.S. patent application Serial No. 27,578, filed May 9, 1960, now Patent No. 3,153,389. The present invention is not concerned broadly with such track correction systems and is useful with these and other systems. The description will be limited to the specific improvements hereby provided in such systems.

These improvements are directed to specific means for providing contacting or supporting engagement with the respective reference lines and means for operating the contacting or supporting means, as will now be described.

The support means for the one tensioned wire 7 and for the other tensioned wire 7' is constituted by peripherally grooved rollers 6 and 6', respectively, which maintain each wire in tensioned condition at a predetermined vertical position. The first roller 6 is freely rotatably journaled in bearing 21 and the second roller 6' is similarly journaled in bearing 21'. Means is provided for interconnecting the first and second wire support means 6, 6', this interconnecting means being constituted by a crossbeam 5 extending transversely of the track and linked at its respective ends to the bearing 21 by pin 22 and to bearing 21' by pin 29. As shown, pin 29 is movable in a slot 24 in the connecting lug fixed to bearing 21' whereby the bearing and the interconnecting crossbeam have some transverse play in relation to one another.

Since the means for anchoring and/or tensioning the wires 7 forms no part of the present invention and may be mounted anywhere on the bogie below the wire support means, the wire tensioning means has not been shown so that the drawing may be clearly directed to the improvements provided by the present invention.

The crossbeam 5 is affixed to a pendulum support frame 8 which is mounted on bogie frame 1. Frame 8 carries suspended thereon a pendulum 9 moving between two electrical contacts 10 and 10' mounted on the pendulum frame adjacent respective sides of the pendulum in a plane transverse to the track to indicate the relative vertical position of the tensioned wires and thereby establishing the horizontal inclination of the plane extending through the wires transversely of the track.

The end of the pendulum, which moves between the

contacts 10, 10' when the relative vertical position of the tensioned wires changes, receives a weak, low-voltage electrical current from an electrical power source 16. The contacts are connected to an electrical control circuit fed by a strong, high-voltage current from electrical power source 15. A grounded relay 11 is connected in the control circuit, branch conductor 10a leading from contact 10 to the relay while contact 10' is connected to the relay by branch conductor 10b. The electrical driving motor 17 is actuated by the electrical control circuit, receiving power from current source 15 which has one terminal connected to the motor by conductor 14 while its other terminal is connected to the motor by conductor 13 and branch conductors 12, 12' leading from the relay 11 to the motor. The motor shaft 17' is rotatable in either direction and is rotated in a selected direction depending on whether the relay shunts the current through conductor 12 or 12'.

As shown, the means for vertically adjustably mounting the first roller 6 is manually operable and includes a threaded sleeve 22 threadedly receiving a threaded rod 20 on which bearing 21 is mounted. By manually, or otherwise, turning the hand wheel 23, the rod 20 is moved vertically in relation to the fixed sleeve 22 which is affixed to the bogie frame 1 by means of bracket 25. The support means 6 is vertically so adjusted that the reference wire 7 assumes a vertical spacing from its associated rail, which is considered most advantageous for the track grading operation over a plurality of adjacent track sections so that the grading operation may be continued without interruption for some time without resetting the vertical position of wire 7.

The additional means for vertically adjustably mounting the second roller 6' is mechanically driven under the control of the above-described electrical control circuit. This additional means includes, in the illustrated embodiment, a guide sleeve 22' affixed to the bogie frame 1 by means of bracket 25'. The spindle 20' is freely rotatably journaled in the guide sleeve and held against axial movement therein by flanges 26, 26' engaging the end walls of the guide sleeve. The outer end of the spindle has a threaded portion 27 which threadedly receives bearing 21'. Since bearing 21' is held against rotation by crossbeam 5, rotation of the spindle 20', with its threaded spindle portion 27, will cause the bearing 21', with its roller 6', to move up or down, depending on the direction of rotation of the spindle.

Rotation of the spindle is provided by a mechanical drive means illustrated to include the motor shaft 17' and the connecting link rod 19. Universal joints, such as the illustrated ball and cup joints 28, 28', connect the respective ends of the link rod 19 to spindle 20' and to a gear means 18 which transmits the rotation of the motor shaft to the link rod and, thus, to the spindle 20'.

The operation of the apparatus will partially be self-evident from the above description of its structure and will be explained hereinbelow in further detail:

As the grading operation proceeds along the track, the bogie, with the two reference wires anchored thereto, is moved on the track to an ungraded track section which, for purposes of the present explanation, is assumed to have an undesired transverse inclination wherein the left rail, as seen in the drawing, lies vertically below the level of the right rail. In such a horizontal inclination of the track plane, the lower end of pendulum 9 will make contact with contact 10'. In this position, relay 11 receives a low-voltage current from battery 16 through branch conductor 10b, the end of the pendulum being electrically connected to the battery. The relay actuates a switch closing the circuit from high-voltage source 15 to branch conductor 12' and thus causing the motor shaft 17' to rotate in such a direction that the corresponding rotation of spindle 20' raises the wire 7' by distance  $x$ , which is the desired vertical position of wire 7' in relation to wire 7. This position may be such that the two wires define a horizontal plane, which is the case in

a straight track section, or an inclined plane of a predetermined angle to the horizontal, which is the case in a curved track section. As soon as this position is reached, the pendulum necessarily assumes a median position between the contacts 10 and 10', being out of contact with both. This causes the current supply to the driving motor 17 to be interrupted by relay 11 and the further vertical movement of spindle 20' and bearing 21' is thus halted.

Obviously, if the inclination were in the opposite direction, i.e. the right rail were lower than the left rail, as seen in the drawing, the pendulum would contact the electrical contact 10, thus causing the current from power source 15 to flow through branch conductor 12 and turn the motor shaft the other way, initiating a reverse vertical movement of the support roller 6'.

The direction of the motor shaft rotation depends on whether the motor receives its power through conductor 12 or 12' and the switch to a respective one of these conductors is closed by the relay, depending on whether the relay is operated by contact 10 or 10'.

It will be clearly understood that the exemplified structural embodiment of the present invention may be suitably varied and modified without in any way departing from the spirit and scope of this invention, as defined in the appended claims. The apparatus is useful in a variety of track grading systems, regardless as to whether the bogie stands still at the end of a track section being graded or whether the same moves simultaneously with the track grading machine along such a section. Also, while a tensioned wire has been specifically illustrated as the reference line, this may be constituted, if desired, by light rays, electromagnetic waves and like means constituting straight lines.

What is claimed is:

1. An apparatus movable on two track rails and useful in track grading operations wherein the rails are leveled in relation to two reference lines defining vertical planes with respective ones of said rails, comprising

(a) means arranged for engagement with, and movable on, said track rails;

(b) a frame mounted on said movable means;

(c) a first means arranged for contacting engagement with one of said reference lines;

(d) means for vertically adjustably mounting said first means on said frame;

(e) a second means arranged for contacting engagement with the other one of said reference lines;

(f) additional means for vertically adjustably mounting said second means on said frame;

(g) mechanical drive means for vertically adjusting said additional means;

(h) a means mounted on said frame for indicating the vertical position of said reference lines relative to each other thereby establishing the horizontal inclination of the plane extending through said reference lines;

(i) control means operating in response to said relative vertical position indicating means of the reference lines and actuating said mechanical drive means.

2. An apparatus movable on two track rails and useful in track grading operations wherein the rails are leveled in relation to two tensioned elongated flexible reference elements defining vertical planes with respective ones of said rails, comprising

(a) means arranged for engagement with, and movable on, said track rails;

(b) a frame mounted on said movable means;

(c) a first means arranged for supporting engagement with one of said reference elements;

(d) means for vertically adjustably mounting said first means on said frame;

(e) a second means arranged for supporting engagement with the other one of said reference elements;

(f) additional means for vertically adjustably mounting said second means on said frame;

(g) mechanical drive means for vertically adjusting said additional means;

5

6

(h) a means mounted on said frame for indicating the vertical position of said reference elements relative to each other, thereby establishing the horizontal inclination of the plane extending through said reference elements; and

(i) control means operating in response to said relative vertical position indicating means of the reference elements and actuating said mechanical drive means.

3. The apparatus of claim 2, wherein said control means includes a pendulum.

4. The apparatus of claim 3, wherein said control means includes electrical contacts mounted adjacent respective sides of said pendulum in a plane transverse to the track, and an electrical control circuit connected to said contacts and actuating said mechanical drive means in a selected vertical direction depending on which of said electrical contacts is contacted by said pendulum.

5. An apparatus movable on two track rails and useful in track grading operations wherein the rails are leveled in relation to two tensioned elongated flexible elements defining vertical planes with respective ones of said rails, comprising

(a) a wheel means arranged for engagement with, and movable on, said track rails;

(b) a frame mounted on said wheel means;

(c) a first means arranged for supporting engagement with one of said tensioned elements;

(d) means for vertically adjustably mounting said first means on said frame;

(e) a second means arranged for supporting engagement with the other one of said tensioned elements;

(f) additional means for vertically adjustably mounting said second means on said frame;

5

10

15

20

25

30

(g) means interconnecting said first and second means, said interconnecting means being mounted on said frame transversely of said track and indicating the vertical position of said tensioned elements relative to each other, thereby establishing the horizontal inclination of the plane extending through said tensioned elements;

(h) mechanically drive means for vertically adjusting said additional means; and

(i) control means operating in response to said relative vertical position indicating means of the tensioned elements and actuating said mechanical drive means, said control means including a pendulum mounted on said interconnecting means and electrical contacts mounted adjacent respective sides of said pendulum in a plane transverse to the track, an electrical drive motor having a shaft rotatable in either direction, an electrical control circuit connecting each of said contacts with said electrical drive motor, closing of said circuit by contact of the pendulum with a respective one of said contacts rotating the motor shaft in a selected one of said directions, and mechanical means for transmitting the shaft rotation to said mechanical drive means.

References Cited by the Examiner

UNITED STATES PATENTS

2,491,275	12/49	Millikan.	
2,974,607	3/61	Talboys	104-7
3,071,082	1/63	Talboys	104-7
3,119,346	1/64	Derler	104-7

ARTHUR L. LA POINT, *Primary Examiner.*

LEO QUACKENBUSH, EUGENE G. BOTZ, *Examiners.*