



- (51) International Patent Classification:
H04R 1/22 (2006.01) H04R 1/30 (2006.01)
- (21) International Application Number:
PCT/EP2014/053222
- (22) International Filing Date:
19 February 2014 (19.02.2014)
- (25) Filing Language: English
- (26) Publication Language: English
- (30) Priority Data:
1303516.7 27 February 2013 (27.02.2013) GB
- (71) Applicant: GP ACOUSTICS (UK) LIMITED [GB/GB];
Eccleston Road, Tovil, Maidstone Kent ME15 6QP (GB).
- (72) Inventors: OCLEE-BROWN, Jack Anthony; 73 Maidstone Road, Paddock Wood, Paddock Wood, Tonbridge Kent TN12 6AE (GB). DODD, Mark; 11 Dukes Park, Woodbridge, Woodbridge, Woodbridge Suffolk IP12 2DD (GB).

- (74) Agent: MACLEAN, Martin; Oak House, Oak End Way, Gerrards Cross Buckinghamshire SL9 8BR (GB).
- (81) Designated States (unless otherwise indicated, for every kind of national protection available): AE, AG, AL, AM, AO, AT, AU, AZ, BA, BB, BG, BH, BN, BR, BW, BY, BZ, CA, CH, CL, CN, CO, CR, CU, CZ, DE, DK, DM, DO, DZ, EC, EE, EG, ES, FI, GB, GD, GE, GH, GM, GT, HN, HR, HU, ID, IL, IN, IR, IS, JP, KE, KG, KN, KP, KR, KZ, LA, LC, LK, LR, LS, LT, LU, LY, MA, MD, ME, MG, MK, MN, MW, MX, MY, MZ, NA, NG, NI, NO, NZ, OM, PA, PE, PG, PH, PL, PT, QA, RO, RS, RU, RW, SA, SC, SD, SE, SG, SK, SL, SM, ST, SV, SY, TH, TJ, TM, TN, TR, TT, TZ, UA, UG, US, UZ, VC, VN, ZA, ZM, ZW.
- (84) Designated States (unless otherwise indicated, for every kind of regional protection available): ARIPO (BW, GH, GM, KE, LR, LS, MW, MZ, NA, RW, SD, SL, SZ, TZ, UG, ZM, ZW), Eurasian (AM, AZ, BY, KG, KZ, RU, TJ, TM), European (AL, AT, BE, BG, CH, CY, CZ, DE, DK, EE, ES, FI, FR, GB, GR, HR, HU, IE, IS, IT, LT, LU, LV, MC, MK, MT, NL, NO, PL, PT, RO, RS, SE, SI, SK, SM,

[Continued on next page]

(54) Title: ACOUSTIC PHASE-PLUG

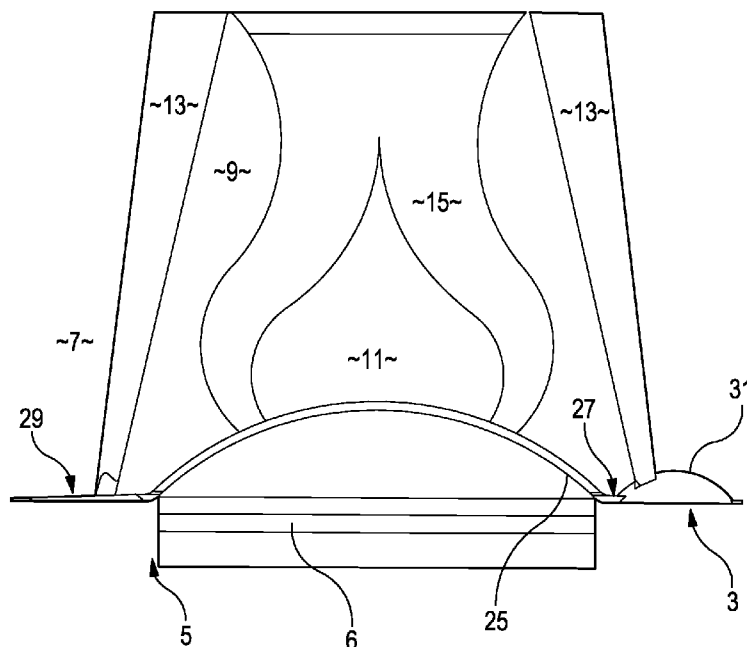

Fig. 4

(57) Abstract: A phase plug for a loudspeaker having a driven diaphragm, wherein at least a portion of the surface of the phase plug disposed in use adjacent the diaphragm is generally annular in two orthogonal directions and has an axis in a third orthogonal direction, and wherein at least a portion of the said annular surface is shaped such that as successive radial cross-sections through the annular surface are generated by rotating a plane about the axis, the cross-sectional shape of the surface of the phase plug varies periodically as the angle of rotation increases.





TR), OAPI (BF, BJ, CF, CG, CI, CM, GA, GN, GQ, GW, KM, ML, MR, NE, SN, TD, TG).

— *as to the applicant's entitlement to claim the priority of the earlier application (Rule 4.17(iii))*

Declarations under Rule 4.17:

— *as to the identity of the inventor (Rule 4.17(i))*

— *of inventorship (Rule 4.17(iv))*

— *as to applicant's entitlement to apply for and be granted a patent (Rule 4.17(ii))*

Published:

— *with international search report (Art. 21(3))*

Acoustic Phase Plug

FIELD OF THE INVENTION

The present invention relates to an acoustic phase plug used in systems for converting electrical signals into sound, such as a phase plug for a compression driver or
5 loudspeaker.

BACKGROUND ART

Phase plugs are usually disposed, in use, adjacent a diaphragm, the diaphragm being driven axially to generate sound waves; these sound waves are channelled by the phase plug so as to enhance the acoustic performance of the diaphragm. Conventional phase-plugs
10 have an axisymmetric surface which closely follows the geometry of the associated diaphragm. The enclosed volume of air between the diaphragm and phase-plug must be sufficiently small to avoid loss of high frequency output due to acoustic compliance. To achieve maximum low frequency output the diaphragm must move with the largest possible displacement.

Some attempts have been made to shape the diaphragm in the axial direction so as to increase its stiffness, and thus improve its acoustic performance; however, the introduction of such shapes inevitably either reduces the clearance between the phase plug and the diaphragm (which is undesirable, as it risks the diaphragm impinging on the phase
15 plug during operation, which has a drastic adverse effect on the sound quality), or it increases the volume of the cavity between the diaphragm and phase-plug, which is also
20 undesirable. As a result of this, and other practical constraints, the size of the axial shaping is severely restricted in the part of the phase plug facing the diaphragm.

SUMMARY OF THE INVENTION

Accordingly the present invention provides a phase plug for a loudspeaker having a
25 driven diaphragm, wherein at least a portion of the surface of the phase plug disposed in use adjacent the diaphragm is generally annular in two orthogonal directions and has an axis in a third orthogonal direction, and wherein at least a portion of the said annular surface is shaped such that as successive radial cross-sections through the annular surface are generated by rotating a plane about the axis, the cross-sectional shape of the surface of

the phase plug intersecting said plane varies as the angle of rotation increases. The variation of the cross-section may be periodic.

Such an arrangement facilitates the shaping of a diaphragm in the axial direction to a significant extent, allowing the stiffness of the diaphragm to be optimised whilst avoiding the problems of diaphragm/phase plug impingement and unnecessarily and undesirably increasing the volume between the diaphragm and phase-plug.

The surface of the phase plug may further comprise one or more axisymmetric areas surrounding the periodically varying shaped portion. The generally annular surface may further comprise an axisymmetric portion inside the annular portion, and/or the surface of the phase plug may comprise a concave portion within the generally annular portion. This concave portion, which may be centred on the axis (and substantially axisymmetric), may be generally dome-shaped - a concave dome shaped as part of a sphere, ellipsoid, paraboloid or hyperboloid, for example.

The phase plug may include at least one channel for sound waves generated by a diaphragm disposed adjacent the phase plug to pass through, the or each channel terminating adjacent the periodically varying shaped portion of the phase plug surface.

The non-axisymmetric portion may extend circumferentially around a concave surface, which may be axisymmetric.. The varying shaped portion may extend smoothly and/or substantially uninterruptedly around the axisymmetric surface. Portions of the surface of the phase plug other than the periodically varying shaped portion(s) may be axisymmetric; apart from the optional central portion of the surface of the phase plug, there may be a substantially flat or planar surface forming an annulus inside and/or outside the varying shaped portion.

The periodically varying shaped portions of the phase plug surface may comprise a series of axial cavities formed in the generally annular surface: this series of cavities may be formed as separate, but substantially similar individual cavities disposed generally circumferentially around the generally annular surface (these cavities may be evenly distributed about the circumference), or it may comprise a single, sinuously shaped cavity. The periodically varying shaped portion may extend substantially uninterruptedly around the annular surface, and/or it may be smooth and blend smoothly with the surrounding portions

of the surface, or it may comprise a series of cavities which are themselves smooth but which are discontinuous where they blend into the generally annular surface of the phase plug. Alternatively or additionally the periodically varying shaped portion(s) may be in the form of a succession of undulations, or of substantially continuous curves, which may have a sinusoidal appearance. The undulations may protrude from the general plane of the annular surface in either or both directions in the axial direction.

The present invention recognises that improved acoustic performance may be achieved by using a geometry for the phase-plug surface which is not wholly axisymmetric but instead is of varying radial cross-sectional shape in an annular region so as to provide a concave and variably shaped region to allow for the termination of a channel for soundwaves generated by the diaphragm thereat. This region may be formed as a series of smoothly-shaped regular cavities in the surface (e.g. circles/domes, triangles, or essentially any rectilinear or curved shape), or as a succession of circumferential undulations in the generally annular portion of the surface of the phase plug. The maximum output for a given cavity volume may be obtained by making the phase-plug surface the same shape as the displaced diaphragm surface. This approach allows much greater freedom in the choice of circumferential undulations and their size. For example the circumferential undulations may even be greater than the phase-plug to diaphragm spacing.

The phase plug will, as is conventional, have one or more channels for soundwaves generated by the diaphragm. These channels may be radial or annular or a series of circular holes or other shape. At least one of these channels may terminate at or adjacent the periodically varying shaped portion of the phase plug surface.

In another aspect, the present invention also encompasses a loudspeaker incorporating a phase plug as described herein.

For convenience, the present invention is principally described herein with reference to a circular phase plug, however the invention applies equally to non-circular phase plugs, such as elliptical or race track shapes, or any shape being symmetrical in two orthogonal directions and lying in the general plane of the phase plug surface which in use is intended to lie adjacent an acoustically-driven diaphragm. Accordingly, or unless clearly indicated otherwise, any use in this description or in the claims of the terms "annular", "circumference", "circumferential", "circumferentially", "concentric" or "around" should not

be construed as being restricted to a circular shape alone, nor as being necessarily centred on a single axis but instead as simply surrounding a boundary. Similarly, the term "appears sinusoidal" should not be construed as limited to a strictly sinusoidal shape, but instead construed broadly as encompassing any substantially smooth series of substantially continuous and substantially cyclical curves.

BRIEF DESCRIPTION OF THE DRAWINGS

An embodiment of the present invention will now be described by way of example, with reference to the accompanying figures in which;

Figure 1 is a schematic view, in perspective, of part of a phase plug in accordance with the invention disposed for use with a diaphragm;

Figure 2 is a perspective view of the diaphragm of Figure 1;

Figure 3 is a perspective view of the concave surface of a phase plug similar to that of Figure 1, and

Figure 4 is a partial cross-sectional view of the plane indicated by the arrows 4-4 in Figure 1.

DETAILED DESCRIPTION OF THE EMBODIMENTS

The phase plug 1 shown in Figure 1 is illustrated as it would be in use in a compression driver, or loudspeaker, disposed adjacent to a diaphragm 3 which is driven by a voice coil 5 (the voice coil 5 is connected to the diaphragm 3 by a bobbin 6, see Figure 4). The phase plug 1 comprises three pieces 7, 9, 11 which are connected as is known in the art and disposed so as to provide two concentric annular channels 13, 15 for the soundwaves generated by the diaphragm 3; the length and shape of these channels are important factors in ensuring that the compression driver is efficient and a high quality of sound reproduction, however the channels do not form part of the present invention *per se*, nor does the precise composition of the phase plug, or its shape and configuration other than adjacent the diaphragm and in relation to one soundwave channel as will become apparent.

As can be seen in Figure 2, the diaphragm 3 has a dome-shaped central portion 17, which extends to a planar region 19, to the reverse of which the voice coil 5 is attached and

is arranged to vibrate the diaphragm 3 parallel to the X axis (Figure 1 shows the orthogonal X, Y and Z axes). Between the central domed portion 17 and the planar region 19 is a blend radius 20. Surrounding the planar region 19 is a generally flat, annular portion 21, disposed circumferentially around which is a plurality of dome-shaped protrusions 23, so that the annular portion 21 of the diaphragm is non-axisymmetric about the X axis, in that as successive radial cross-sections through the annular surface are generated by rotating a plane about the X axis, the cross-sectional shape of the surface of the phase plug varies periodically as the angle of rotation increases. Figure 2 shows a diaphragm having in total 13 protrusions 23 distributed evenly about the plane of the generally annular portion 21, and the complementary phase plug would have a corresponding number and distribution of cavities.

The surface of the phase plug 1 is configured and disposed relative to the diaphragm 3 so as to provide an air cavity 25 (see Figure 4) therebetween, the dimensions of which are most important: for maintaining loudspeaker efficiency at high frequencies, the volume of the air cavity 25 must be small, but the distance between the diaphragm 3 and the adjacent face of the phase plug 1 (i.e. in the X direction in the drawings) must be sufficiently large so that no part of the diaphragm impinges on the phase plug when the diaphragm is being driven. Accordingly, the surface of the phase plug 1 intended to be adjacent the diaphragm 3 in use is concavely dome-shaped in its centre, with a narrow planar annular region 27 to match region 19 of the diaphragm/drive coil, and then has a generally planar, annular portion 29 in which there are concave depressions, or cavities 31 (more easily seen in Figure 3) to accommodate the protrusions 23. The cavities are evenly distributed about the annulus 29. As can be seen in Figures 1 and 4, one of the sound channels (the innermost channel 15) terminates at the dome-shaped part of the phase plug/diaphragm, while the other, outermost channel 13 terminates at the annular portion 29. The termination of the channel 13 at portion 29 (see Figure 4) occurs at a point coincident with the dome-shaped cavities 31. Accordingly, whereas the termination of the inner channel 15 forms an axisymmetric annulus around the circumference of the dome, the termination of the outer channel 13 adjacent the diaphragm is non-axisymmetric, and forms a series of undulations which can be inferred from Figure 4. Preferably these undulations are relatively smooth, apart from the intersections of the protrusions 23 with the annular portion 21, which are quite sharp (and as shown in the drawings, Figure 3 in particular). Alternatively, these intersections may be relatively smoothly radiussed.

Referring to Figure 3, this illustrates an alternative phase plug 1' which has a central dome-shaped concave depression 33 with three separate channels for soundwaves generated by the dome-shaped part of the diaphragm (not shown). A channel terminating along the line of the circumferential cavities 31 is not shown in Figure 3, so that the cavities
5 31 can be more clearly appreciated. It will also be understood that the number and disposition of cavities and channels can vary, and that the number, shape and configuration of channels can vary; what is significant for the purpose of this invention is that the phase plug adjacent the diaphragm has an essentially annular portion 21 (but which should not necessarily be planar, or indeed have any part at all which is planar) which is shaped so as
10 to vary in cross-section as already described, in order to provide a non-axisymmetric surface for at least one soundwave channel to terminate on. We have found that such a shape of phase plug surface is conducive both to high frequency efficiency and sound quality across a wide bandwidth; also adjusting the size and/or number of undulations at the termination of the channel in the phase plug allows "tuning", a process well-known in the art, so as for
15 example to minimise modal excitation and/or interference, whilst maintaining or improving efficiency.

Typically the phase-plug to diaphragm spacing may be in the region of 0.1mm - 1.2mm and the ratio of the effective diaphragm radiating area to phase-plug entrance area, also called compression ratio, is between 5 and 12. The mean flux at the voice coil is limited
20 by the saturation of the iron poles and is between 1.2 Tesla and 2.1 Tesla depending on the magnet size and cost. The majority of compression drivers use a titanium diaphragm and an aluminium voice coil, which is often copper clad to improve electrical connectivity.

Figure 3 shows a phase plug having in total 45 cavities distributed evenly about the plane of the generally annular portion 29; it will be appreciated that each cavity therefore
25 subtends 8 degrees of the total circle of rotation.

It will of course be understood that many variations may be made to the above-described embodiment without departing from the scope of the present invention. For example, although the drawings illustrate a series of dome-shaped cavities 31, these may be of any smoothly concave shape (e.g. elliptical, ovoid, rectangular, lozenge, etc.), or even be
30 formed of a continuously curved surface having radial and/or circumferential undulations, which may appear sinusoidal and which may be periodically or cyclically curved. There may

be any number of cavities, and these may be arranged in one or more circumferential rows, which can be aligned, staggered or arranged symmetrically, according to the relevant acoustic desiderata. Similarly, although the phase plug in the drawings has a generally dome-shaped or spherical central cavity, this may be of any smoothly curved shape, such as
5 an ellipsoid, hyperboloid or paraboloid or a surface derived from a part of the surface of a toroid, and although shown as axi-symmetric the shape of this cavity may be non-axisymmetric. The cavities are shown evenly spaced around a circle, however for some applications the cavities could be unevenly spaced, and /or the cycle of any curves could vary. Furthermore, where different variations or alternative arrangements are described
10 above, it should be understood that embodiments of the invention may incorporate such variations and/or alternatives in any suitable combination.

CLAIMS

1. A phase plug for a loudspeaker having a driven diaphragm, wherein at least a portion of the surface of the phase plug which in use is disposed adjacent to the diaphragm is generally annular in two orthogonal directions and has an axis in a third
5 orthogonal direction, and wherein at least a portion of the said annular surface is shaped such that as successive radial cross-sections through the annular surface are generated by rotating a plane about the axis, the cross-sectional shape of the surface of the phase plug varies periodically as the angle of rotation increases.
2. A phase plug according to Claim 1, wherein the surface of the phase plug further
10 comprises axisymmetric areas surrounding the periodically varying shaped portion.
3. A phase plug according to Claim 1 or Claim 2, wherein the said generally annular surface further comprises an axisymmetric portion inside the annular portion.
4. A phase plug according to Claim 1, 2 or 3, wherein the surface of the phase plug further comprises a concave portion within the said annular portion.
- 15 5. A phase plug according to any preceding claim wherein the phase plug has at least one channel for the passage of sound waves generated by a diaphragm disposed adjacent the phase plug, which channel terminates adjacent the periodically varying shaped portion of the phase plug surface.
6. A phase plug according to any preceding claim wherein the periodically varying
20 shaped portions comprise cavities formed in the annular surface portion of the phase plug.
7. A phase plug according to any of Claims 1 to 5, wherein the periodically varying shaped portion extends smoothly and/or substantially uninterruptedly around the annular surface.
- 25 8. A phase plug according to Claim 7, wherein the periodically varying shaped portion comprises undulations formed in the annular surface portion of the phase plug.
9. A phase plug according to Claim 8 wherein the undulations form a succession of substantially continuous curves when viewed along the axis.

10. A phase plug according to Claim 9 wherein the curves appear circumferentially sinusoidal.
11. A phase plug according to Claim 8, 9 or 10 wherein the undulations protrude from the generally annular surface of the phase plug in either or both directions along the
5 said axis.
12. A loudspeaker comprising a phase plug according to any preceding Claim.
13. A phase plug substantially as described hereinbefore and with reference to the accompanying drawings.

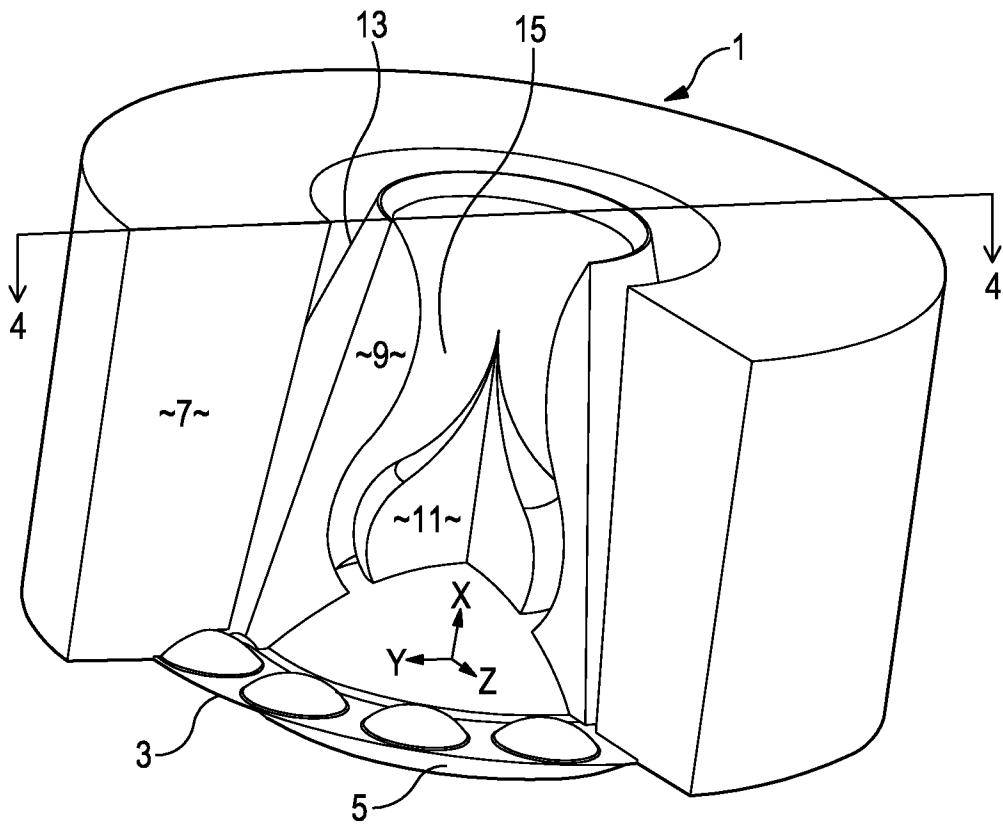

Fig. 1

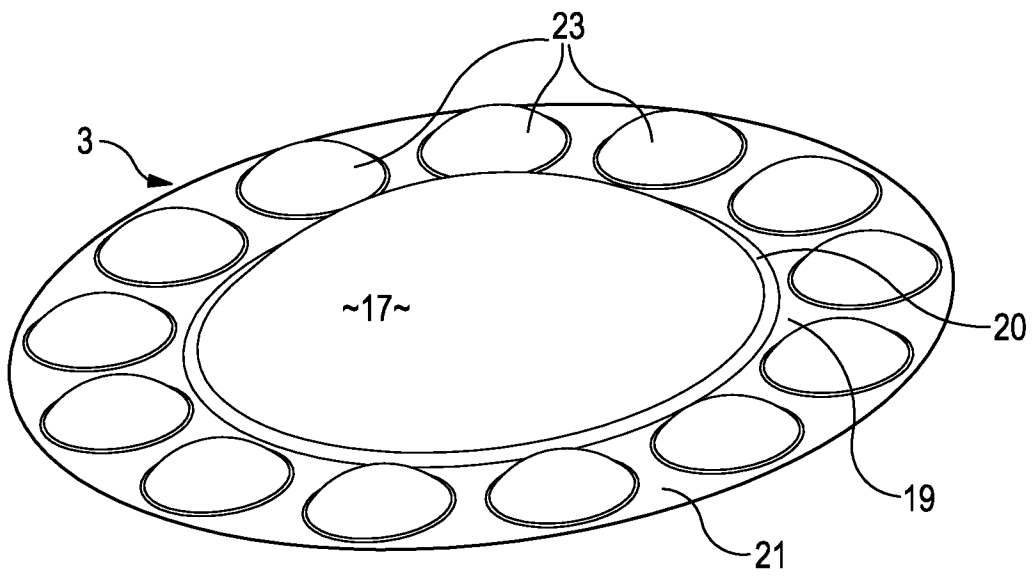

Fig. 2

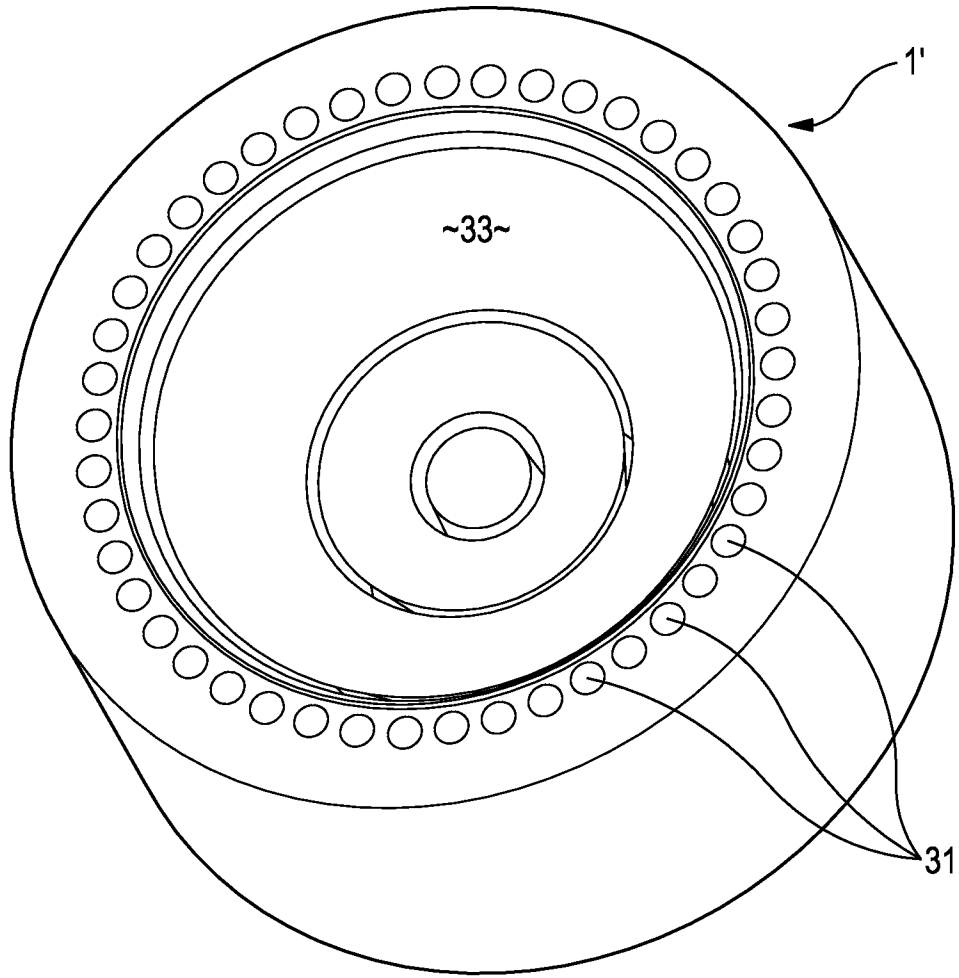

Fig. 3

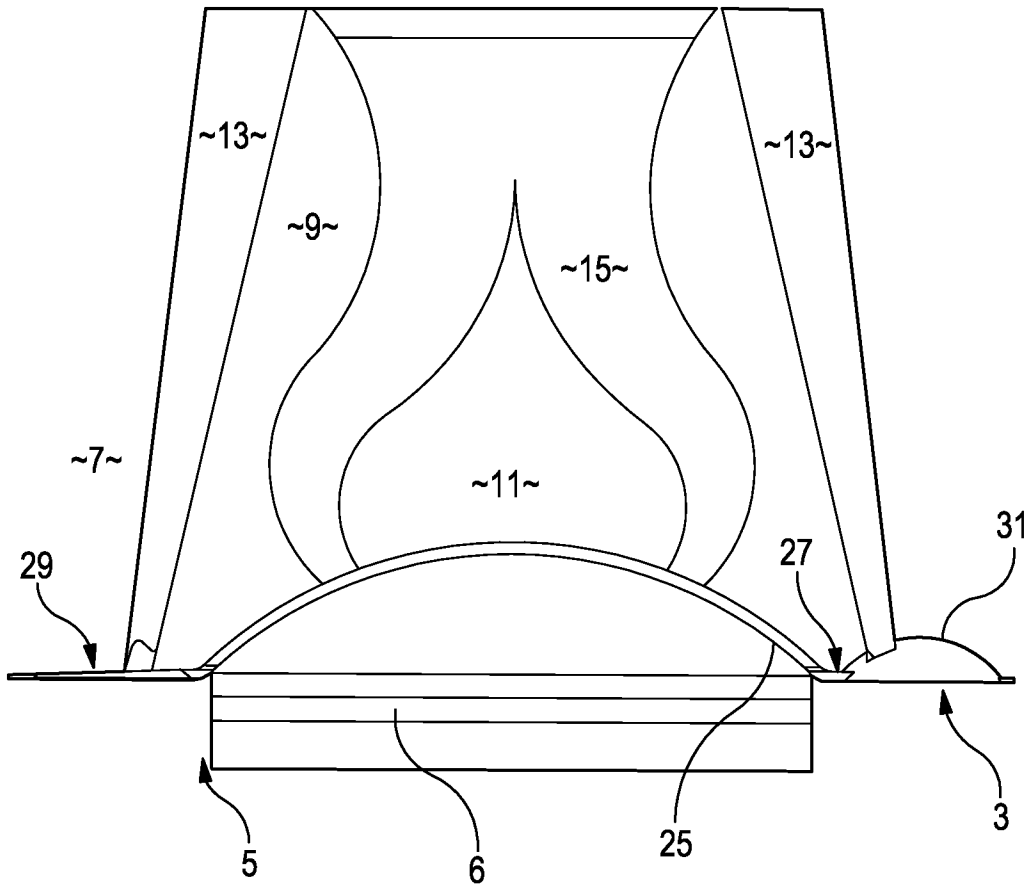

Fig. 4

INTERNATIONAL SEARCH REPORT

International application No
PCT/EP2014/053222

A. CLASSIFICATION OF SUBJECT MATTER
INV. H04R1/22
ADD. H04R1/30

According to International Patent Classification (IPC) or to both national classification and IPC

B. FIELDS SEARCHED

Minimum documentation searched (classification system followed by classification symbols)
H04R

Documentation searched other than minimum documentation to the extent that such documents are included in the fields searched

Electronic data base consulted during the international search (name of data base and, where practicable, search terms used)
EPO-Internal, WPI Data

C. DOCUMENTS CONSIDERED TO BE RELEVANT

Category*	Citation of document, with indication, where appropriate, of the relevant passages	Relevant to claim No.
X	US 5 117 462 A (BIE DAVID D [US]) 26 May 1992 (1992-05-26) the whole document -----	1-13
X	WO 2004/040942 A1 (AEB SRL [IT]; MANZINI ANDREA [IT]; PRATI STEFANO [IT]; STORCHI UMBERTO) 13 May 2004 (2004-05-13) the whole document -----	1-13
A	JP H05 183986 A (MATSUSHITA ELECTRIC IND CO LTD) 23 July 1993 (1993-07-23) abstract; figures 1,4 -----	1-13
A	US 2001/040974 A1 (STECKLING JEROME D [US]) 15 November 2001 (2001-11-15) the whole document -----	1-13

Further documents are listed in the continuation of Box C.

See patent family annex.

* Special categories of cited documents :

- "A" document defining the general state of the art which is not considered to be of particular relevance
- "E" earlier application or patent but published on or after the international filing date
- "L" document which may throw doubts on priority claim(s) or which is cited to establish the publication date of another citation or other special reason (as specified)
- "O" document referring to an oral disclosure, use, exhibition or other means
- "P" document published prior to the international filing date but later than the priority date claimed

- "T" later document published after the international filing date or priority date and not in conflict with the application but cited to understand the principle or theory underlying the invention
- "X" document of particular relevance; the claimed invention cannot be considered novel or cannot be considered to involve an inventive step when the document is taken alone
- "Y" document of particular relevance; the claimed invention cannot be considered to involve an inventive step when the document is combined with one or more other such documents, such combination being obvious to a person skilled in the art
- "&" document member of the same patent family

Date of the actual completion of the international search 28 April 2014	Date of mailing of the international search report 08/05/2014
--	--

Name and mailing address of the ISA/ European Patent Office, P.B. 5818 Patentlaan 2 NL - 2280 HV Rijswijk Tel. (+31-70) 340-2040, Fax: (+31-70) 340-3016	Authorized officer Bücker, Martin
--	--

INTERNATIONAL SEARCH REPORT

Information on patent family members

International application No

PCT/EP2014/053222

Patent document cited in search report	Publication date	Patent family member(s)	Publication date
US 5117462	A	26-05-1992	NONE

WO 2004040942	A1	13-05-2004	AU 2003230219 A1 25-05-2004
			CN 1613272 A 04-05-2005
			EP 1557070 A1 27-07-2005
			US 2005105753 A1 19-05-2005
			WO 2004040942 A1 13-05-2004

JP H05183986	A	23-07-1993	NONE

US 2001040974	A1	15-11-2001	NONE
