



US00D744964S

(12) **United States Design Patent**  
**Sachsenweger**

(10) **Patent No.:** **US D744,964 S**

(45) **Date of Patent:** **\*\* Dec. 8, 2015**

(54) **LED LIGHTING MODULE**

(71) Applicant: **OSRAM GmbH**, Munich (DE)

(72) Inventor: **Peter Sachsenweger**, Zeitlarn (DE)

(73) Assignee: **OSRAM GmbH**, Munich (DE)

(\*\*) Term: **14 Years**

(21) Appl. No.: **29/487,453**

(22) Filed: **Apr. 9, 2014**

(30) **Foreign Application Priority Data**

Oct. 18, 2013 (EM) ..... 002328997

(51) **LOC (10) Cl.** ..... **13-03**

(52) **U.S. Cl.**

USPC ..... **D13/180; D26/1**

(58) **Field of Classification Search**

USPC ..... D13/180; D26/1

CPC ... H01L 25/167; H01L 25/0753; H01L 27/15;

H01L 27/156; H01L 31/02; H01L 33/00;

H01L 33/04; H01L 33/08; H01L 33/10;

H01L 33/20; H01L 33/38; H01L 33/42;

H01L 33/48; H01L 33/483; H01L 33/486;

F21K 9/00; F21K 9/30; F21K 9/54; F21V

15/01

See application file for complete search history.

(56) **References Cited**

**U.S. PATENT DOCUMENTS**

D568,832 S \* 5/2008 Kang et al. .... D13/180

D666,333 S \* 8/2012 Kim et al. .... D26/2

(Continued)

**FOREIGN PATENT DOCUMENTS**

DE 102012206077 A1 10/2013

DE 102012211553 A1 1/2014

WO 2013153211 A1 10/2013

**OTHER PUBLICATIONS**

English abstract for DE 10 2012 211 553 dated Jan. 9, 2014.

*Primary Examiner* — Selina Sikder

(57) **CLAIM**

The ornamental design for a LED lighting module, as shown and described.

**DESCRIPTION**

FIG. 1 is a perspective view of a first embodiment of a lighting module,

FIG. 2 is a top view of the first embodiment of the lighting module,

FIG. 3 is a front view of the first embodiment of the lighting module,

FIG. 4 is a right side view of the first embodiment of the lighting module,

FIG. 5 is a back view of the first embodiment of the lighting module,

FIG. 6 is a left side view of the first embodiment of the lighting module,

FIG. 7 is a bottom view of the first embodiment of the lighting module,

FIG. 8 is a perspective view of a second embodiment of the lighting module,

FIG. 9 is a top view of the second embodiment of the lighting module,

FIG. 10 is a front view of the second embodiment of the lighting module,

FIG. 11 is a right side view of the second embodiment of the lighting module,

FIG. 12 is a back view of the second embodiment of the lighting module,

FIG. 13 is a left side view of the second embodiment of the lighting module; and,

FIG. 14 is a bottom view of the second embodiment of the lighting module.

The broken lines shown on the drawing views are for illustrative purposes only and forms no part of the claimed design.

**1 Claim, 10 Drawing Sheets**

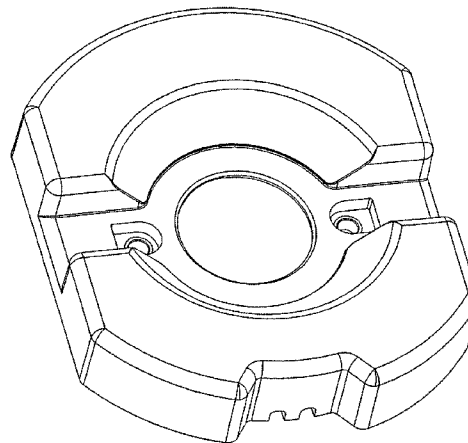
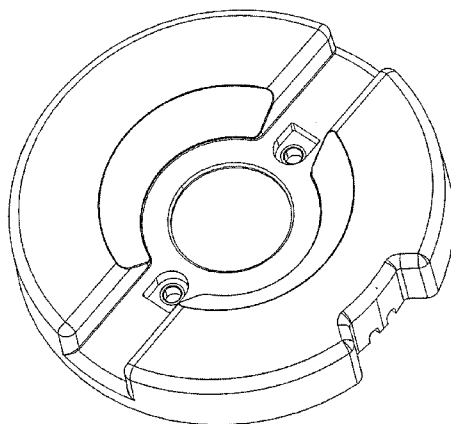

(56)

**References Cited**

U.S. PATENT DOCUMENTS

8,684,568	B2 *	4/2014	Nagaoka et al. ....	362/374	2012/0038293	A1 *	2/2012	Guerrieri et al. ....	315/313
8,690,389	B2 *	4/2014	Zaderej .....	362/249.02	2012/0051068	A1 *	3/2012	Pelton et al. ....	362/373
8,773,007	B2 *	7/2014	Van De Ven et al. ....	313/318.01	2012/0099328	A1 *	4/2012	Miyashita et al. ....	362/311.05
8,783,938	B2 *	7/2014	Alexander et al. ....	362/655	2012/0127739	A1 *	5/2012	Takahara et al. ....	362/373
8,858,045	B2 *	10/2014	Harbers et al. ....	362/433	2013/0272016	A1 *	10/2013	Weaver .....	362/555
D728,129	S *	4/2015	Kreuzbichler .....	D26/1	2013/0343034	A1 *	12/2013	Harbers et al. ....	362/84
D731,988	S *	6/2015	Urtiga et al. ....	D13/180	2014/0218933	A1 *	8/2014	Feng et al. ....	362/296.01
D736,974	S	8/2015	Hammer et al.		2014/0268832	A1 *	9/2014	Goto et al. ....	362/382
2010/0127282	A1 *	5/2010	Harbers et al. ....	257/89	2014/0321117	A1 *	10/2014	Farmer .....	362/235
2010/0208474	A1 *	8/2010	Hancock et al. ....	362/375	2015/0009670	A1 *	1/2015	Van De Ven et al. ....	362/249.02
2011/0193111	A1 *	8/2011	Seo et al. ....	257/89	2015/0023011	A1 *	1/2015	Takei .....	362/231
2011/0316420	A1 *	12/2011	Chang et al. ....	315/51	2015/0078017	A1 *	3/2015	Frost et al. ....	362/382
					2015/0124455	A1 *	5/2015	Tamura et al. ....	362/293
					2015/0131299	A1 *	5/2015	Meyer et al. ....	362/373

\* cited by examiner

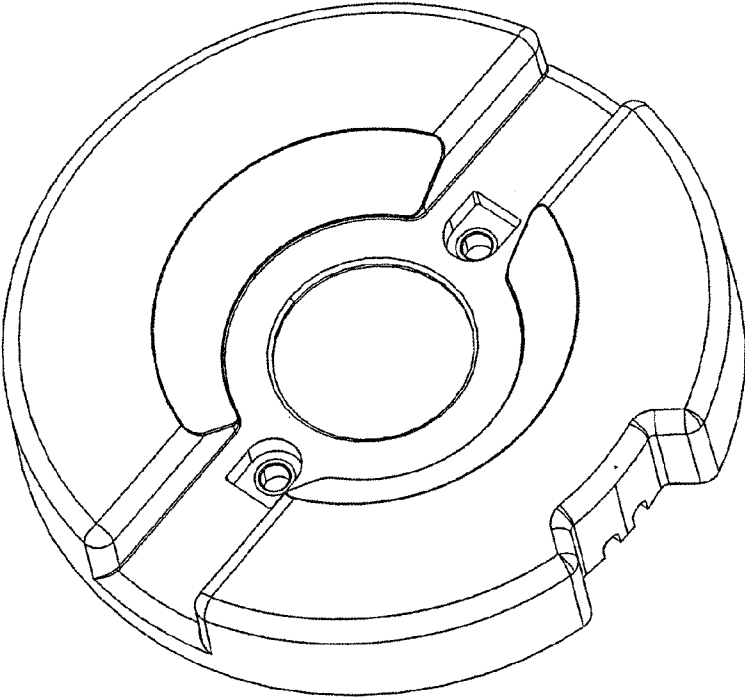

Fig. 1

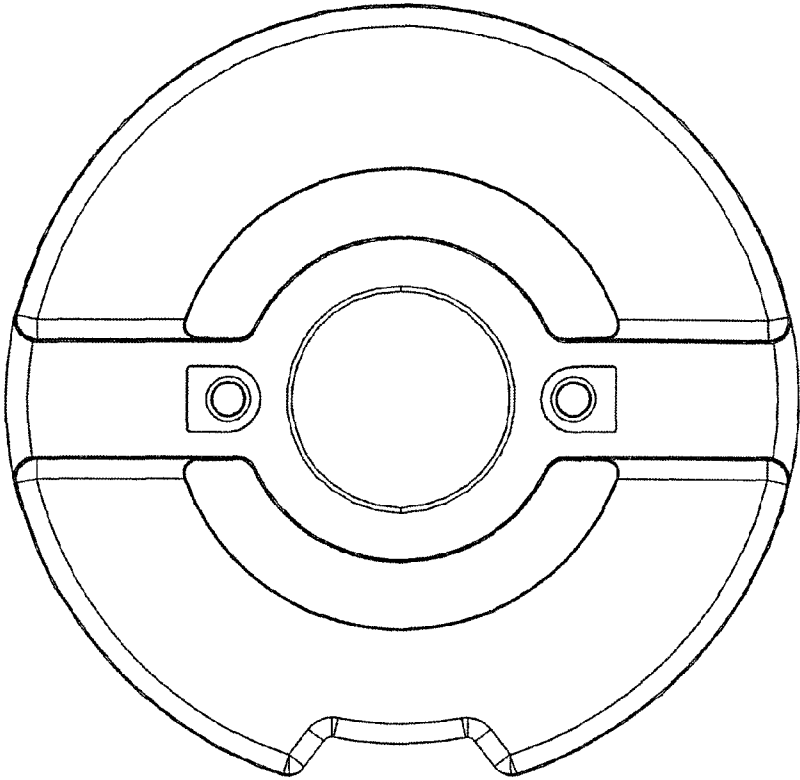

Fig. 2

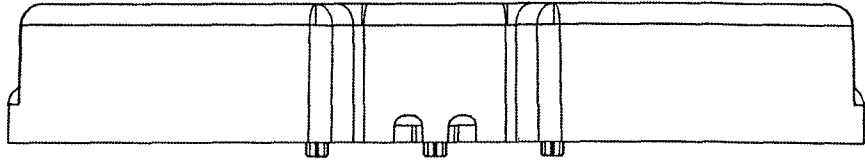

Fig. 3

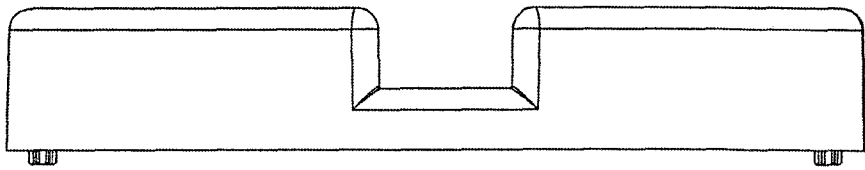

Fig. 4



Fig. 5

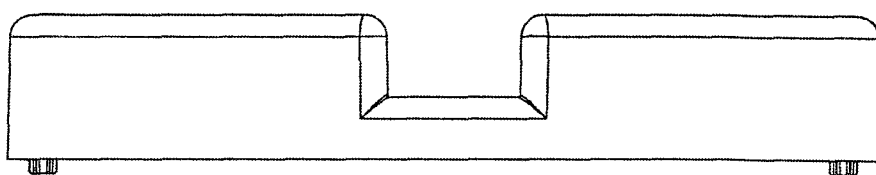

Fig. 6

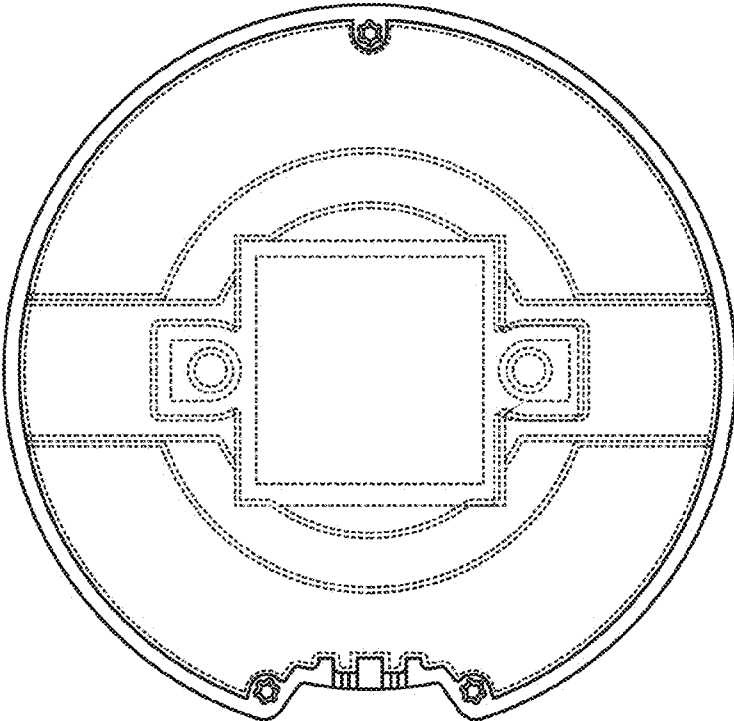

Fig. 7

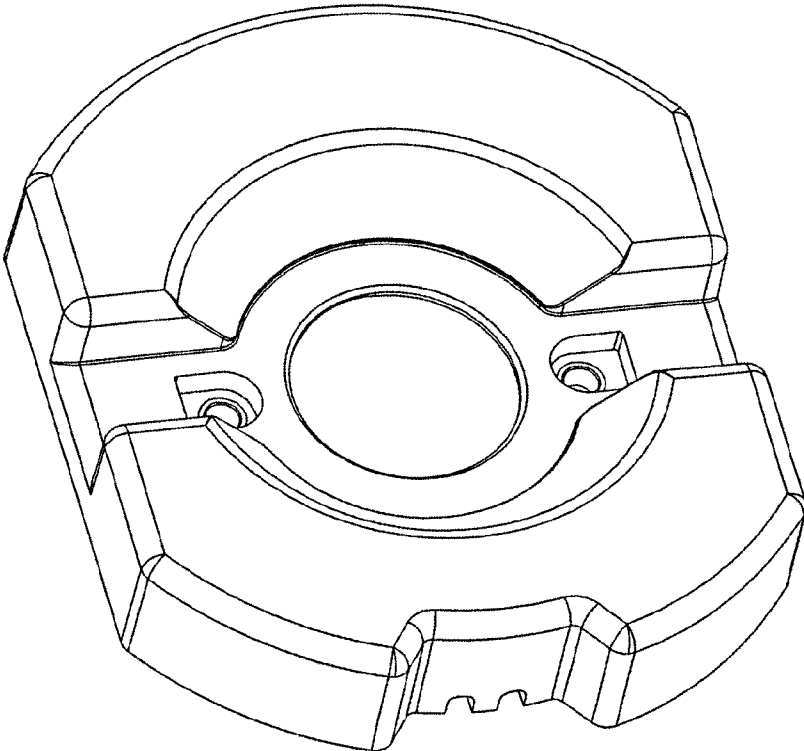

Fig. 8

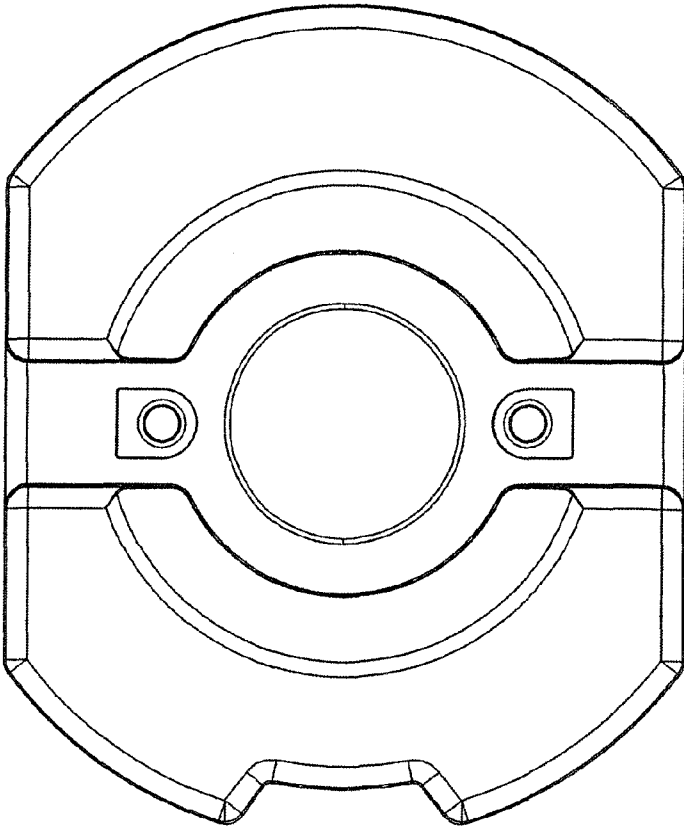

Fig. 9

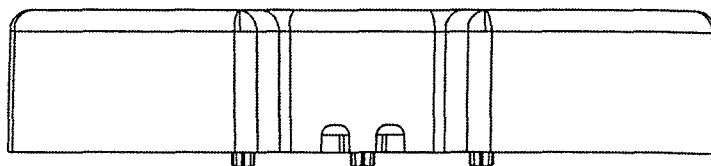

Fig. 10

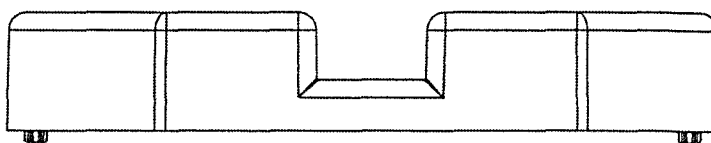

Fig. 11

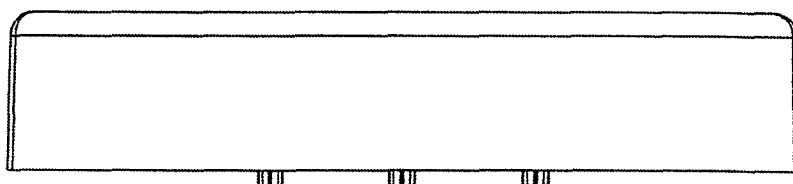

Fig. 12

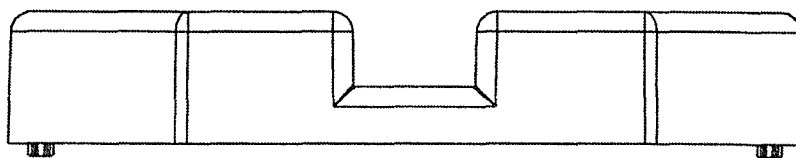

Fig. 13

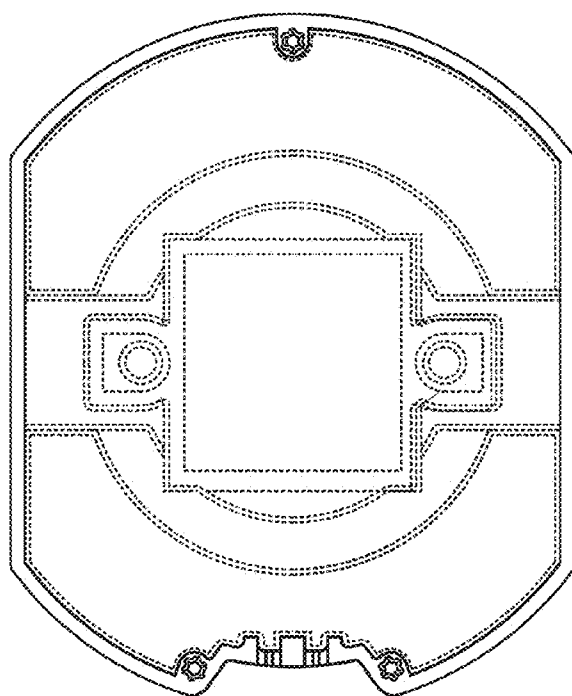

Fig. 14