

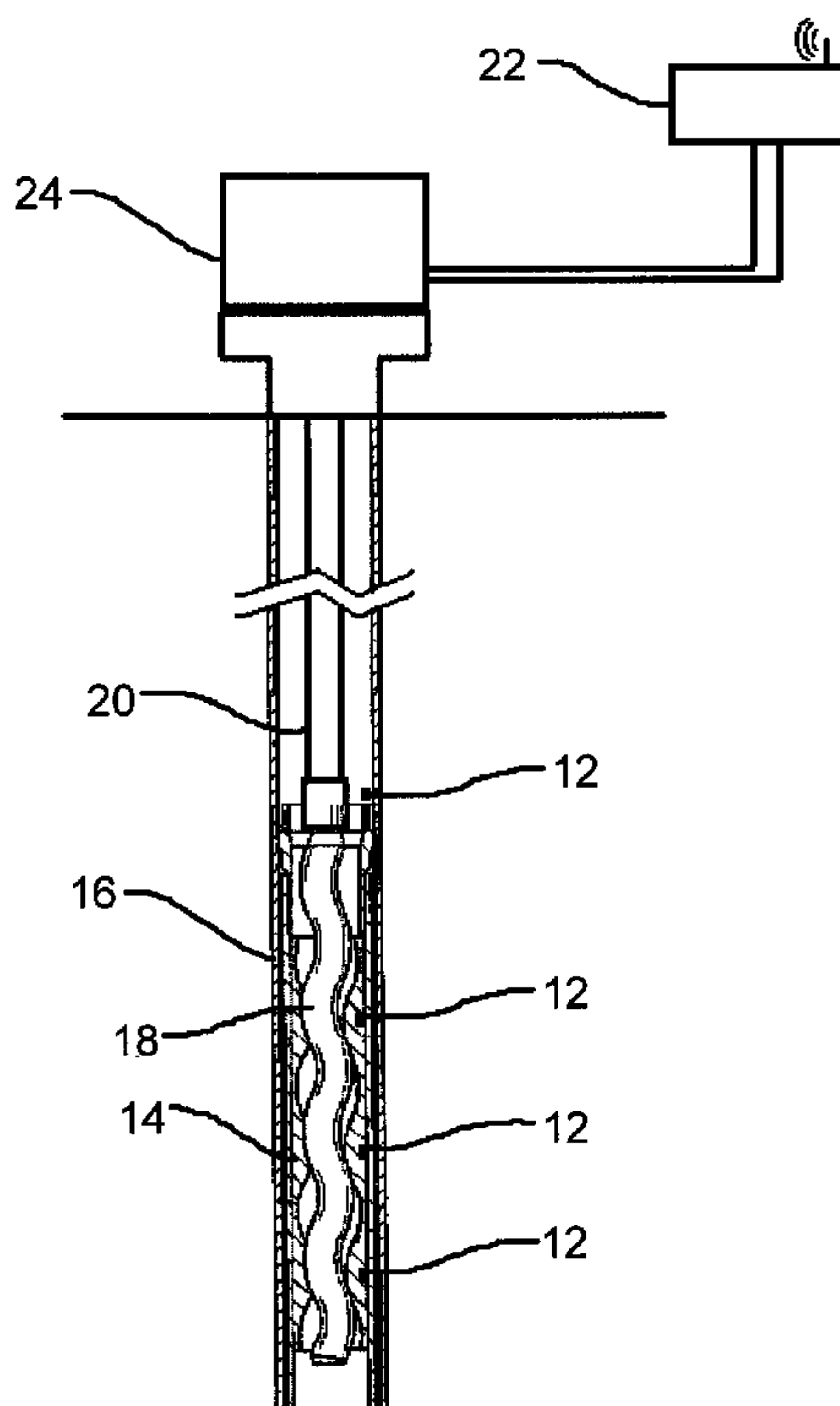

(22) Date de dépôt/Filing Date: 2008/11/10
(41) Mise à la disp. pub./Open to Public Insp.: 2009/05/08
(30) Priorité/Priority: 2007/11/08 (US60/986,314)

(51) Cl.Int./Int.Cl. *F04C 14/08* (2006.01),
E21B 47/06 (2006.01), *F04C 14/28* (2006.01)
(71) Demandeur/Applicant:
NORALTA CONTROLS LTD., CA
(72) Inventeurs/Inventors:
ZAROWNY, CAMERON, CA;
MUIR, WAYNE, CA;
YOUNG, WENDELL, CA
(74) Agent: THOMPSON, DOUGLAS B.

(54) Titre : SYSTEME DE VIDANGE
(54) Title: FLUSH-BY SYSTEM



(57) **Abrégé/Abstract:**

An apparatus for controlling a downhole pump. The pump has a stator, a rotor and a pump drive. The temperature monitoring apparatus includes at least one temperature sensor positioned downhole in thermal communication with the downhole pump for measuring the downhole temperature of the downhole pump, and a pump controller connected to the temperature sensor by a wireless communication link for receiving measurements from the temperature sensor. The pump controller has controls for controlling the speed of the pump.

ABSTRACT OF THE DISCLOSURE

An apparatus for controlling a downhole pump. The pump has a stator, a rotor and a pump drive. The temperature monitoring apparatus includes at least one temperature sensor positioned downhole in thermal communication with the downhole pump for measuring the
5 downhole temperature of the downhole pump, and a pump controller connected to the temperature sensor by a wireless communication link for receiving measurements from the temperature sensor. The pump controller has controls for controlling the speed of the pump.

TITLE

[0001] Downhole pump controller

FIELD

5 [0002] The present invention relates to an apparatus for monitoring the temperature of a downhole pump and controlling a downhole pump.

BACKGROUND

10 [0003] As the operating temperature of a progressive cavity pump increases, the wear and risk of failure also increases. Therefore, the temperature of the production flow as it exits the wellhead is commonly monitored.

SUMMARY

15 [0004] There is provided an apparatus for controlling a downhole pump. The downhole pump has a stator, a rotor and a pump drive. The temperature monitoring apparatus comprises at least one temperature sensor positioned downhole in thermal communication with the downhole pump for measuring the downhole temperature of the downhole pump, and a pump controller connected to the temperature sensor by a wireless communication link for receiving measurements from the temperature sensor. The pump controller comprises
20 controls for controlling the speed of the pump.

BRIEF DESCRIPTION OF THE DRAWINGS

25 [0005] These and other features will become more apparent from the following description in which reference is made to the appended drawings, the drawings are for the purpose of illustration only and are not intended to be in any way limiting, wherein:

THE FIGURE is a schematic view in partial section of a temperature monitoring apparatus

DETAILED DESCRIPTION

30 [0006] A downhole pump temperature monitor generally identified by reference numeral 10, will now be described with reference to **THE FIGURE**.

[0007] Structure and Relationship of Parts:

[0008] The temperature of a downhole pump 16, such as a progressive cavity pump, is monitored by placing temperature sensors 12 downhole in thermal communication with the stator 14 of a downhole pump 16. The rotor 18 of the pump 16 is turned by a rod string 20 which is driven by the pump driver 24. The temperature readings from sensors 12 are transmitted to the surface via a communication link, preferably via a wireless communication link, and are received by a controller 22. Controller 22 is programmed with a set of instructions to either slow down or speed up pump driver 24 in response to the temperature measurements to maximize production while reducing unnecessary wearing, or reducing the risk of damage to pump 16. Alternatively, controller 22 may be manually operated to reduce or increase the speed of pump driver 24. Controller 22 may operate locally or remotely. If it is operated remotely, a relay may be set up to transmit the wireless signal from sensors 12 to controller 22.

15

[0009] There may be a single sensor 12, or there may be multiples sensors positioned at intervals along stator 14, such as at different stages of pump 16. Sensors 12 may be beneficially embedded in the stator 14 as depicted, or positioned to contact the output flow from the downhole pump 16, or a combination of both, to help determine the operating temperature of pump 16. Other locations may also be used to position sensors 12.

20

[0010] In this patent document, the word "comprising" is used in its non-limiting sense to mean that items following the word are included, but items not specifically mentioned are not excluded. A reference to an element by the indefinite article "a" does not exclude the possibility that more than one of the element is present, unless the context clearly requires that there be one and only one of the elements.

25

[0011] The following claims are to understood to include what is specifically illustrated and described above, what is conceptually equivalent, and what can be obviously substituted. Those skilled in the art will appreciate that various adaptations and modifications of the described embodiments can be configured without departing from the scope of the claims.

30

The illustrated embodiments have been set forth only as examples and should not be taken as limiting the invention. It is to be understood that, within the scope of the following claims, the invention may be practiced other than as specifically illustrated and described.

What is claimed is:

1. An apparatus for controlling a downhole pump having a stator, a rotor and a pump drive, the apparatus comprising:
 - 5 at least one temperature sensor positioned downhole with the downhole pump in thermal communication with the stator;
a pump controller connected to the temperature sensor by a wireless communication link for receiving measurements from the temperature sensor, the pump controller comprising controls for controlling the speed of the pump.
- 10 2. The apparatus of claim 1, the pump controller further comprising a set of instruction for controlling the speed of the pump in response to measurements from the temperature sensor transmitted via the communication link.
- 15 3. The apparatus of claim 1, wherein the temperature sensor is embedded in the stator.
4. The apparatus of claim 1, comprising a series of temperature sensors along a length of the stator.
- 20 5. The apparatus of claim 1, wherein the temperature sensor is positioned at a discharge end of the stator.
6. A method for controlling the speed of a pump having a stator, a rotor and a pump drive, the method comprising the steps of:
 - 25 positioning at least one temperature sensor downhole with the downhole pump in thermal communication with the stator of the pump;
transmitting temperature measurements from the temperature sensor to a pump controller via a wireless communication link;
controlling the speed of the pump based on the temperature measurements from the
30 stator of the pump.

7. The method of claim 6, further comprising the step of programming the pump controller with a set of instruction for controlling the speed of the pump in response to measurements from the temperature sensor transmitted via the wireless communication link.
8. The method of claim 6, wherein positioning at least one temperature sensor comprises
5 embedding the sensor in the stator.
9. The method of claim 6, wherein positioning at least one temperature sensor comprises positioning a series of temperature sensors along a length of the stator.
- 10 10. The method of claim 6, wherein the temperature sensor is positioned at a discharge
end of the stator.
11. The method of claim 6, wherein the downhole pump is a progressive cavity pump.

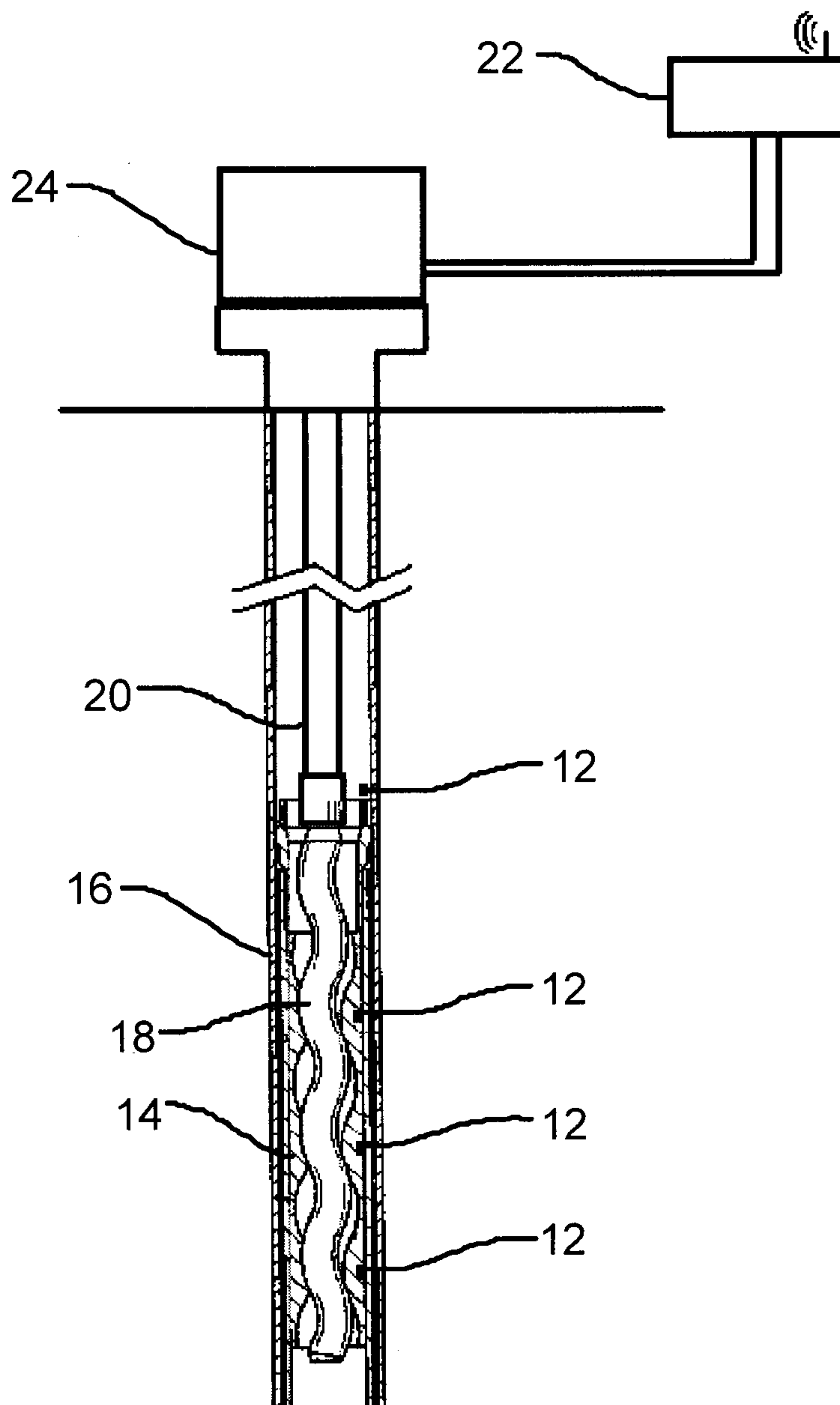

THE FIGURE

