

(12) INTERNATIONAL APPLICATION PUBLISHED UNDER THE PATENT COOPERATION TREATY (PCT)

(19) World Intellectual Property
Organization
International Bureau

(43) International Publication Date
20 June 2019 (20.06.2019)



(10) International Publication Number
WO 2019/118276 A1

(51) International Patent Classification:

A43B 13/12 (2006.01) A43B 13/02 (2006.01)
A43B 13/00 (2006.01) A43B 13/40 (2006.01)

(21) International Application Number:

PCT/US2018/064292

(22) International Filing Date:

06 December 2018 (06.12.2018)

(25) Filing Language:

English

(26) Publication Language:

English

(30) Priority Data:

17/01302 13 December 2017 (13.12.2017) FR

(71) Applicant: **THE NORTH FACE APPAREL CORP.**
[US/US]; 3411 Silverside Road, Wilmington, DE 19810
(US).

(72) Inventors: **GEIS, Benoit**; 4, Rue De Guebwiller, 68700
Wattwiller (FR). **SHENGCHING, Wu**; No. 36,ln. 365,
Sec. 3, Goofing Rd., Fengyuan Dist., Taichung City, 420
(TW).

(74) Agent: **GANZ, Bradley, M.**; Ganz Pollard, LLC, P.O. Box,
Hillsboro, OR 97123 (US).

(81) Designated States (unless otherwise indicated, for every
kind of national protection available): AE, AG, AL, AM,
AO, AT, AU, AZ, BA, BB, BG, BH, BN, BR, BW, BY, BZ,
CA, CH, CL, CN, CO, CR, CU, CZ, DE, DJ, DK, DM, DO,
DZ, EC, EE, EG, ES, FI, GB, GD, GE, GH, GM, GT, HN,
HR, HU, ID, IL, IN, IR, IS, JO, JP, KE, KG, KH, KN, KP,
KR, KW, KZ, LA, LC, LK, LR, LS, LU, LY, MA, MD, ME,
MG, MK, MN, MW, MX, MY, MZ, NA, NG, NI, NO, NZ,
OM, PA, PE, PG, PH, PL, PT, QA, RO, RS, RU, RW, SA,
SC, SD, SE, SG, SK, SL, SM, ST, SV, SY, TH, TJ, TM, TN,
TR, TT, TZ, UA, UG, US, UZ, VC, VN, ZA, ZM, ZW.

(84) Designated States (unless otherwise indicated, for every
kind of regional protection available): ARIPO (BW, GH,
GM, KE, LR, LS, MW, MZ, NA, RW, SD, SL, ST, SZ, TZ,
UG, ZM, ZW), Eurasian (AM, AZ, BY, KG, KZ, RU, TJ,
TM), European (AL, AT, BE, BG, CH, CY, CZ, DE, DK,
EE, ES, FI, FR, GB, GR, HR, HU, IE, IS, IT, LT, LU, LV,
MC, MK, MT, NL, NO, PL, PT, RO, RS, SE, SI, SK, SM,
TR), OAPI (BF, BJ, CF, CG, CI, CM, GA, GN, GQ, GW,
KM, ML, MR, NE, SN, TD, TG).

(54) Title: ATHLETIC SHOE WITH A SHELL INSERTED BETWEEN THE UPPER AND A COMFORT SOLE

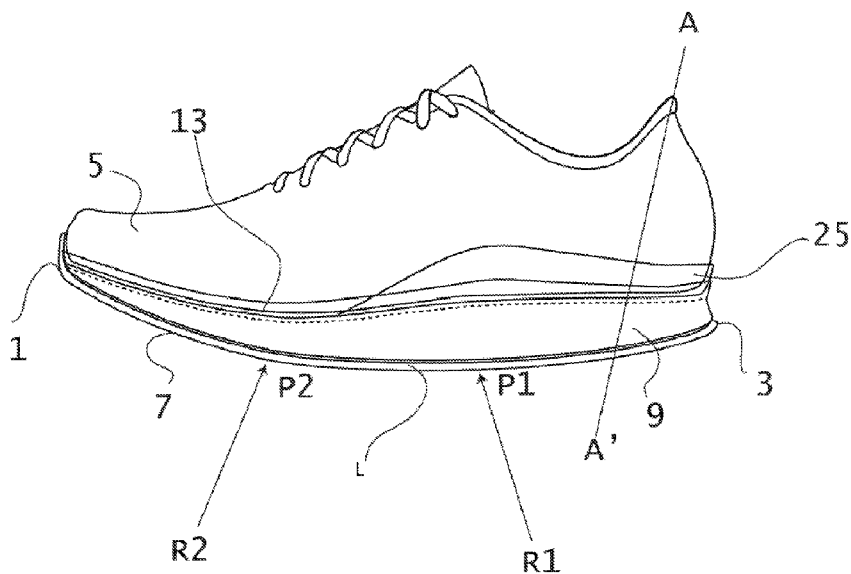

Fig 1

(57) Abstract: An athletic shoe extending between toe (1) and heel (3) and comprising upper (5) attached to outsole (7) via comfort sole (9). According to the invention, the athletic shoe comprises shell (13) make of plastic or composite material, inserted between upper (5) and comfort sole (9) and to which it is attached at heel (1).



WO 2019/118276 A1

Published:

— *with international search report (Art. 21(3))*

ATHLETIC SHOE WITH A SHELL INSERTED BETWEEN THE UPPER AND A COMFORT SOLE

BACKGROUND

The invention pertains to an athletic shoe specifically comprised of an upper attached to an
5 outsole via a comfort sole.

A shoe of this type is known from document EP 3 114 955. From the heel to the toe of the shoe, a rubber outsole is attached to a first comfort sole made of expanded polyurethane. A second ethylene-vinyl acetate (EVA) comfort sole is perforated, so that the upper is attached to the first sole and the second comfort sole. The expanded polyurethane increases the cushioning effect of the first comfort sole.

10 Document FR 2 898 252 also describes an athletic shoe of the type indicated in the introduction, but which is distinguished by the fact that a two-part composite material insert is attached to the outsole and the comfort sole at the heel and attached to the comfort sole and the upper at the toe of the shoe. This part of the composite material insert increases the elasticity of the toe of the shoe.

15 According to this prior art, it is found that at the heel, the upper is in direct contact with the comfort sole. The object of the invention is to modify this prior art in order to better control the support phase of the athletic shoe.

SUMMARY

For this purpose, the subject of the invention is an athletic shoe conforming to the type indicated in the introduction, characterized in that it comprises a shell made of plastic or composite material
20 inserted between the upper and the comfort sole and with which it is attached at the heel.

The shell, made of plastic or composite material, imparts torsional and flexural rigidity to the upper that counteracts foot displacement during impacts between the heel of the shoe and the ground and thus contributes to the stability of the support. By elastically deforming, it also allows a fraction of the energy released by the shock to be restored during relaxation by reducing the fraction of energy dissipated
25 by the comfort sole.

Preferably, the shell of plastic or composite material is inserted and attached to the upper and the comfort sole up to the toe.

Through this arrangement, the shell deforms elastically during the entirety of a stride, from the heel to the toe of the shoe, and provides a stimulating effect to the foot enclosed by the upper by returning the stored energy.

Also preferably, the plastic shell or composite material is inserted and attached to the upper and
5 the comfort sole via a shell bottom and a shell side.

The shell side forms an edge around the shell bottom to allow the shell to stabilize the foot vis-à-vis the ground during a stride, on the one hand. The foot enclosed by the upper is thus kept in the alignment held by the shoe at the time of the impact of the heel with the ground. On the other hand, the edge of the shell side increases the shell's flexional and torsional rigidity. This arrangement is more
10 specifically suitable for road running.

In one embodiment, the shell side surrounds a portion of the shell bottom corresponding to the heel and is disconnected along a portion of said shell bottom corresponding to the toe.

The disconnection of the shell side gives the toe of the shoe flexibility while maintaining stiffness in the heel. This arrangement is more specifically suitable for track running.

15 In another embodiment, the shell side forms an edge around said shell bottom.

The shell side forms an edge around the shell bottom to allow the shell to stabilize the foot vis-à-vis the ground during a stride, on the one hand. The foot enclosed by the upper is thus kept in the alignment held by the shoe at the time of the impact of the heel with the ground. On the other hand, the edge of the shell side increases the shell's flexional and torsional rigidity. This arrangement is more
20 specifically suitable for road running.

Preferably, the shell side is equipped with notches.

This arrangement makes it possible to vary the stiffness of the shell by delimiting rigid sections of the shell side, causing flexibility between the sections due to the notches. It is particularly suitable for mountain runs, known as "trail running".

25 Also, preferably, the shell bottom is perforated.

A perforated shell bottom makes it possible to reduce the weight of the shell while maintaining the rigidity supplied by the shell side.

Advantageously, the comfort sole has a radius of curvature at all points of a line from the heel to the toe and creates an interface with the outsole.

The curvature of the comfort sole eliminates the overlap effect of the initial impact felt with a comfort sole without curvature. The transition between the impact and the roll of the foot is instantaneous.
5 Combined with the stiffness of the composite shell, the bend of the comfort sole promotes the return of energy and thereby permitting faster, and therefore more powerful, strides.

Other advantages of the invention will emerge in the description of embodiments illustrated by the drawings.

BRIEF DESCRIPTION OF THE DRAWINGS

10 Figure 1 is a side view of a first embodiment of the invention.

Figure 2 is an expanded view of Figure 1.

Figure 3 is a view along cross-section A-A' of Figure 1.

Figure 4 is a side view of a second embodiment of the invention.

Figure 5 is an expanded view of Figure 4.

15 Figure 6 is a view along cross-section B-B' of Figure 4.

Figure 7 is a side view of a first variant of the second embodiment of the invention.

Figure 8 is a view of the shell of the first variant illustrated in Figure 7.

Figure 9 is a side view of a second variant of the second embodiment of the invention.

Figure 10 is a view of the shell of the second variant illustrated in Figure 9.

20 DETAILED DESCRIPTION

According to a first embodiment of the invention, Figures 1 to 3, an athletic shoe extends between toe 1 and heel 3 and comprises upper 5 attached to outsole 7 via comfort sole 9.

Outsole 7 is made of an adherent material such as a rubber and is intended to provide a good grip on the ground and good resistance to abrasion. Comfort sole 9 acts as a shock absorber and absorbs
25 shocks during the shoe's contact with the ground, in particular by heel 3. It also has controlled torsional and flexional rigidity characteristics. Upper 5 serves to keep the foot enclosed in the shoe, and for this

purpose, it is provided with closure system 11 using laces or quick fastener strips. Outsole 7 and comfort sole 9 are connected to each other, for example by gluing, from toe 1 to heel 3. Outsole 7 may be equipped with tip 71 at toe 1 of the shoe.

5 According to the invention, the athletic shoe comprises shell 13 made of plastic or composite material, inserted between upper 5 and comfort sole 9 and to which it is attached to heel 3. Corresponding to heel 3 of the shoe, rear portion 51 of upper 5 is, for example, glued to rear portion 17 of shell 13, and likewise, said rear portion 17 is glued to rear portion 91 of comfort sole 9. Gluing can be replaced by cementing.

10 In the embodiment illustrated in Figures 1 to 3, shell 13 extends from rear portion 17 corresponding to heel 3, to front portion 19 corresponding to toe 1. However, shell 13 may only extend for a distance less than the distance between heel 3 and toe 1. Reference 21 has a dotted line showing an end of front portion 19 of shell 13, at a distance from rear portion 17 that is less than the distance between heel 3 and toe 1 of the shoe. In this case, upper 5 is in direct contact with comfort sole 9 in the part of toe 1 of the shoe where shell 13 is not inserted.

15 Shell 13 is inserted between upper 5 and comfort sole 9 and attached to these two elements by heel 3 in order to impart, on the one hand, torsional and flexional rigidity to the upper.

20 During the impact of the heel 3 of the shoe and the ground, shell 13 counteracts displacement of the foot enclosed in upper 5, thus contributing to the stability of the support. On the other hand, the shell is made of plastic or composite material to allow a fraction of the energy released by the impact to be restored during relaxation by reducing the fraction of energy dissipated by the comfort sole.

Shell 13 is attached to upper 5 and comfort sole 9 via shell bottom 23 and shell side 25.

In this first embodiment, the shell side surrounds bottom shell 23 along rear portion 17 of shell 13 corresponding to heel 1 and is disconnected along shell bottom 23 in front portion 19 of shell 13 corresponding to toe 1.

25 As indicated above, the disconnection of shell side 25 gives toe 1 of the shoe flexibility while maintaining stiffness in heel 3. This arrangement is more specifically suitable for track running.

A second embodiment, illustrated by Figures 4 to 6, differs from the previous embodiment in that here, shell side 25 forms an edge around shell bottom 23.

As indicated above, shell side 25 forms an edge around shell bottom 23 to allow shell 13 to stabilize the foot vis-à-vis the ground during a stride, on the one hand. The foot enclosed by upper 5 is thus kept in the alignment held by the shoe at the time of the impact of heel 3 with the ground. On the other hand, the periphery of shell side 25 increases the flexional and torsional rigidity of shell 13. This arrangement is more specifically suitable for road running.

As indicated above, this arrangement makes it possible to vary the stiffness of shell 13 by delimiting rigid sections of shell side 25, causing flexibility between the sections due to notches. Notches 27 are arranged along the periphery of shell bottom 13, in front portion 19 of shell 13. They correspond, for example, to the position of the joints between the metatarsal and the phalanges and between the phalanges and the toes of the foot. This variant of the embodiment is particularly suitable for mountain runs, known as “trail running”.

According to a second variant of the second embodiment, Figures 9 and 10, bottom shell 23 is perforated. Cavity 29 reduces the weight of shell 13 while maintaining the rigidity provided by shell side 25.

In the first or second embodiment, comfort sole 9 has radius of curvature R at any point P on line L from heel 3 to toe 1. In Figures 1 and 4, points $P1$ and $P2$ of line L have radii of curvature $R1$ and $R2$.

As indicated above, the curvature of comfort sole 9 eliminates the overlap effect of the initial impact felt with a comfort sole without curvature. The transition between the impact and the roll of the foot is instantaneous. Combined with the stiffness of composite shell 13, the bend of comfort sole 9 promotes the return of energy and thereby permitting faster, and therefore more powerful, strides.

The shell is preferably made from a polymer resin impregnated with fiberglass or carbon fibers. It can also be manufactured by injection of a thermoplastic or thermosetting material. The torsional and flexional rigidity will be adjusted for a given material according to its thickness and its geometry, in particular the height of the shell side. The comfort layer is preferably made of EVA, but it can also be made of a viscoelastic material or a polyurethane foam.

The shoe construction according to the invention is based on a concept according to which each element of the sole fulfills a distinct function, the modulation of which can be used to respond to different sports practices, be it on the road, on tracks, or in the mountains. It helps keep the foot in place and guide it, and combines cushioning and stride recovery.

WE CURRENTLY CLAIM:

1. An athletic shoe extending between toe (1) and heel (3) and comprising upper (5) attached to
outsole (7) via comfort sole (9) and shell (13) made of plastic or composite materials inserted
between upper (5) and comfort sole (9) and to which it is attached at heel (3) up to toe (1) through
5 shell bottom (23) and shell side (25), characterized in that shell side (25) forms an edge around
said shell bottom (23) and has notches (27) arranged at front section (19) of shell (13).

2. An athletic shoe claimed in Claim 1, wherein bottom shell (23) is perforated.
10

3. An athletic shoe claimed in Claim 1, wherein comfort sole (9) has radius of curvature (R1, R2) at
any point (P1, P2) on line (L) from heel (3) to toe (1) and creates an interface with outsole (7).

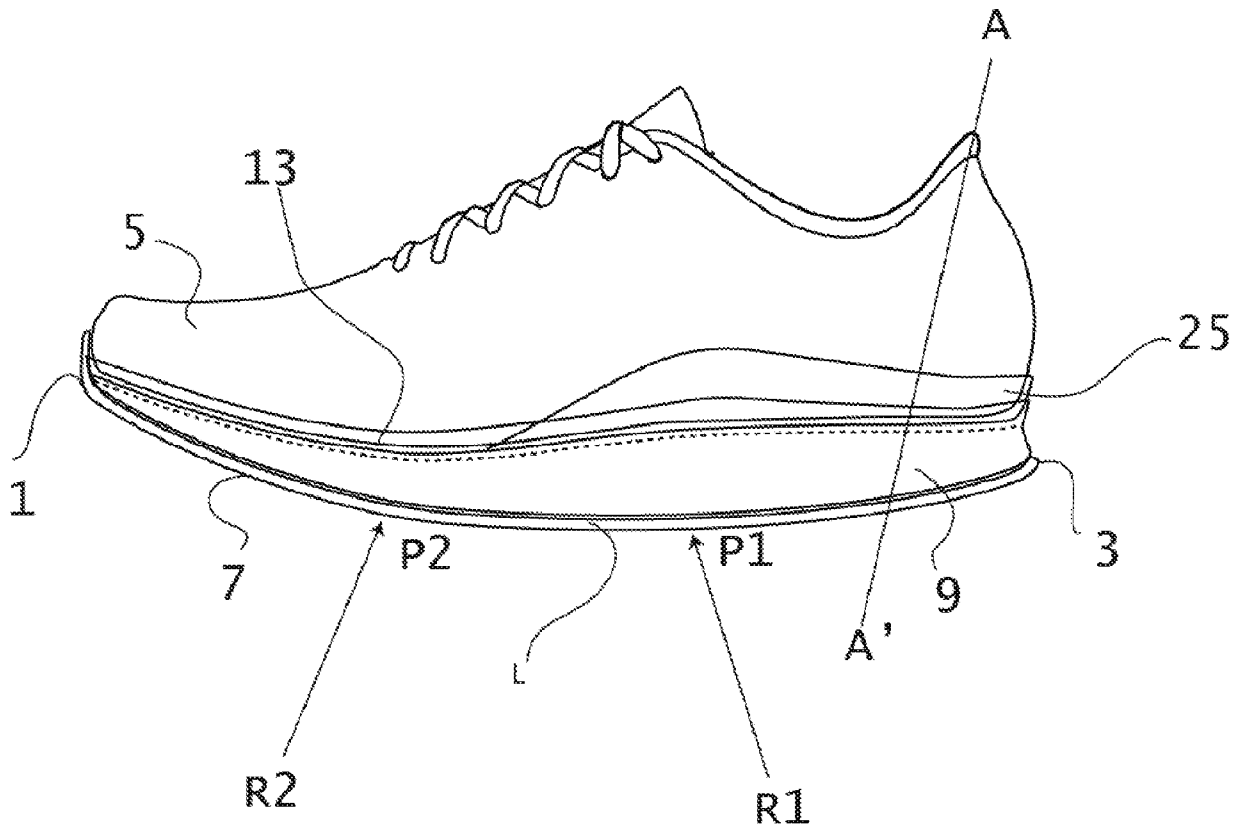

Fig 1

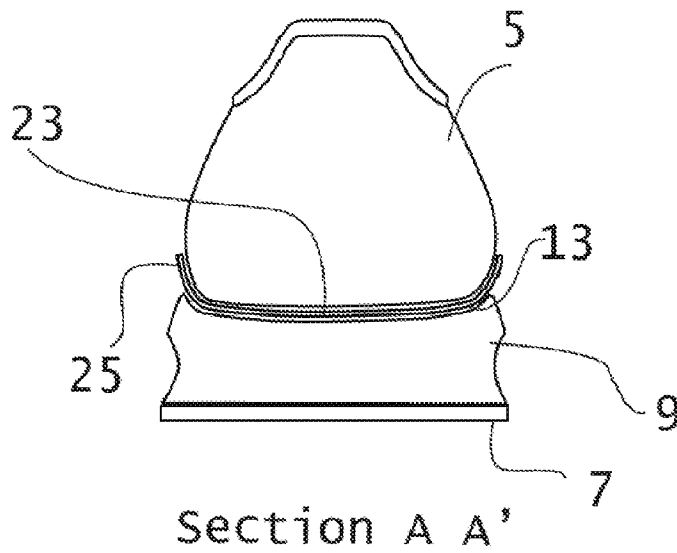

Fig 3

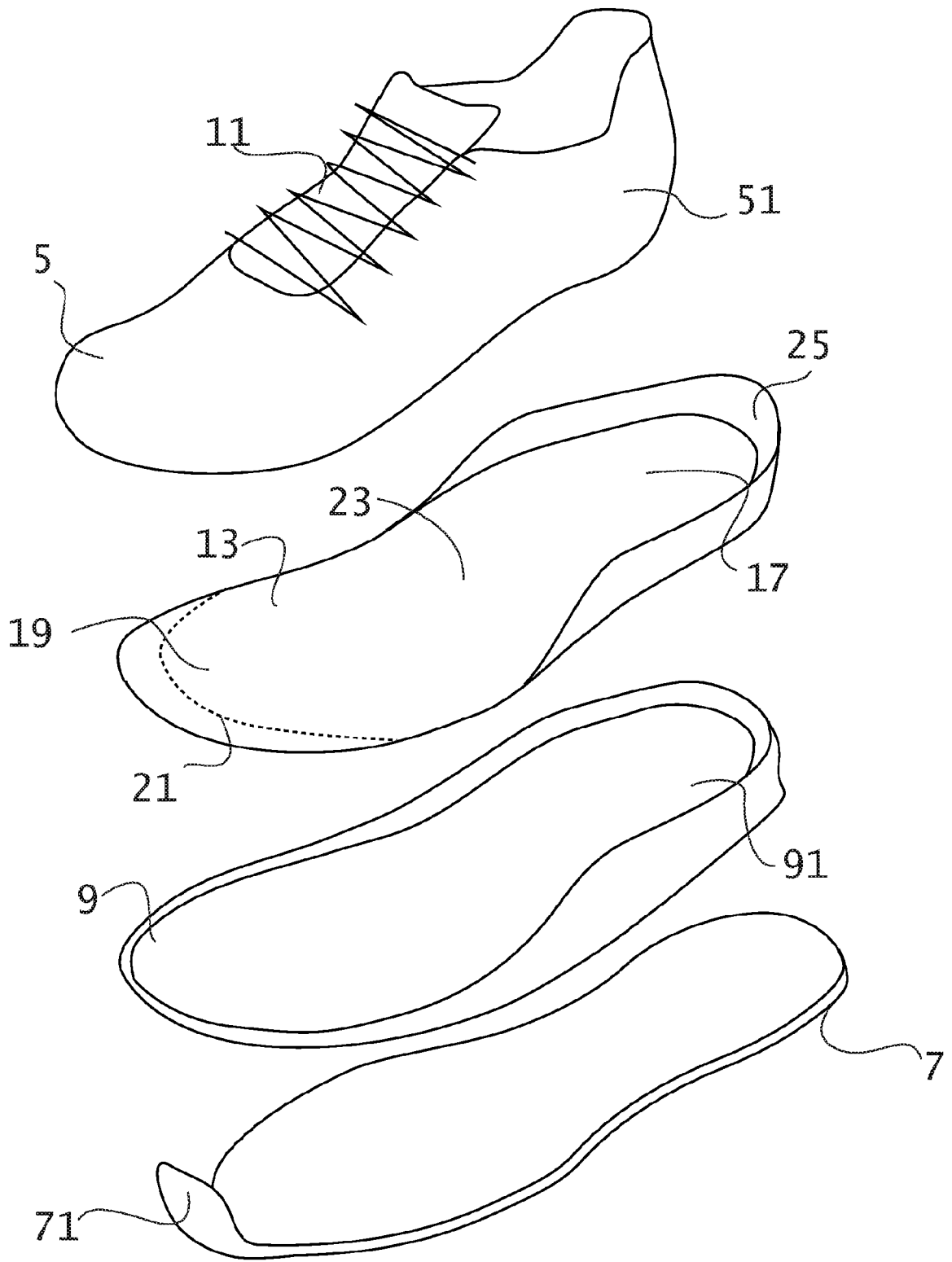

Fig 2

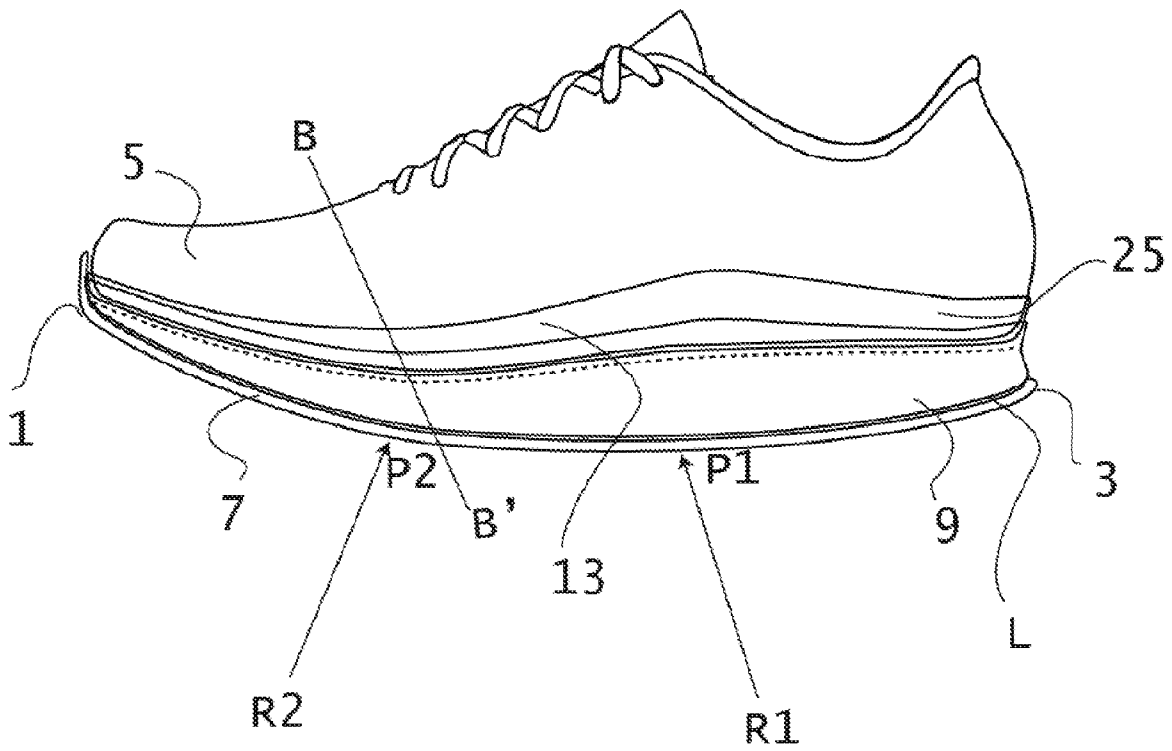
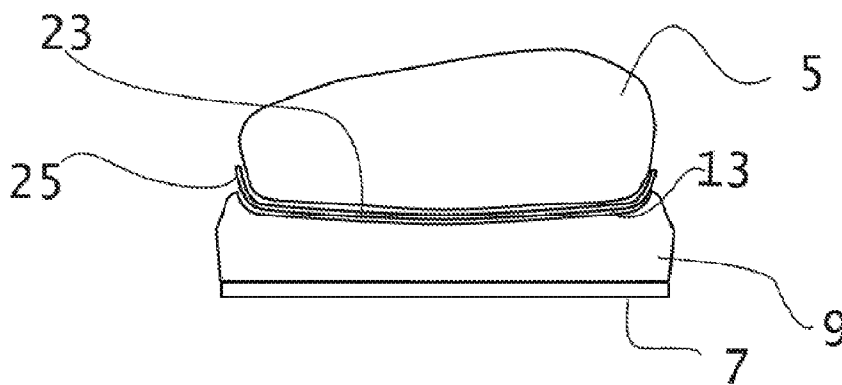

Fig 4



Section B B'

Fig 6

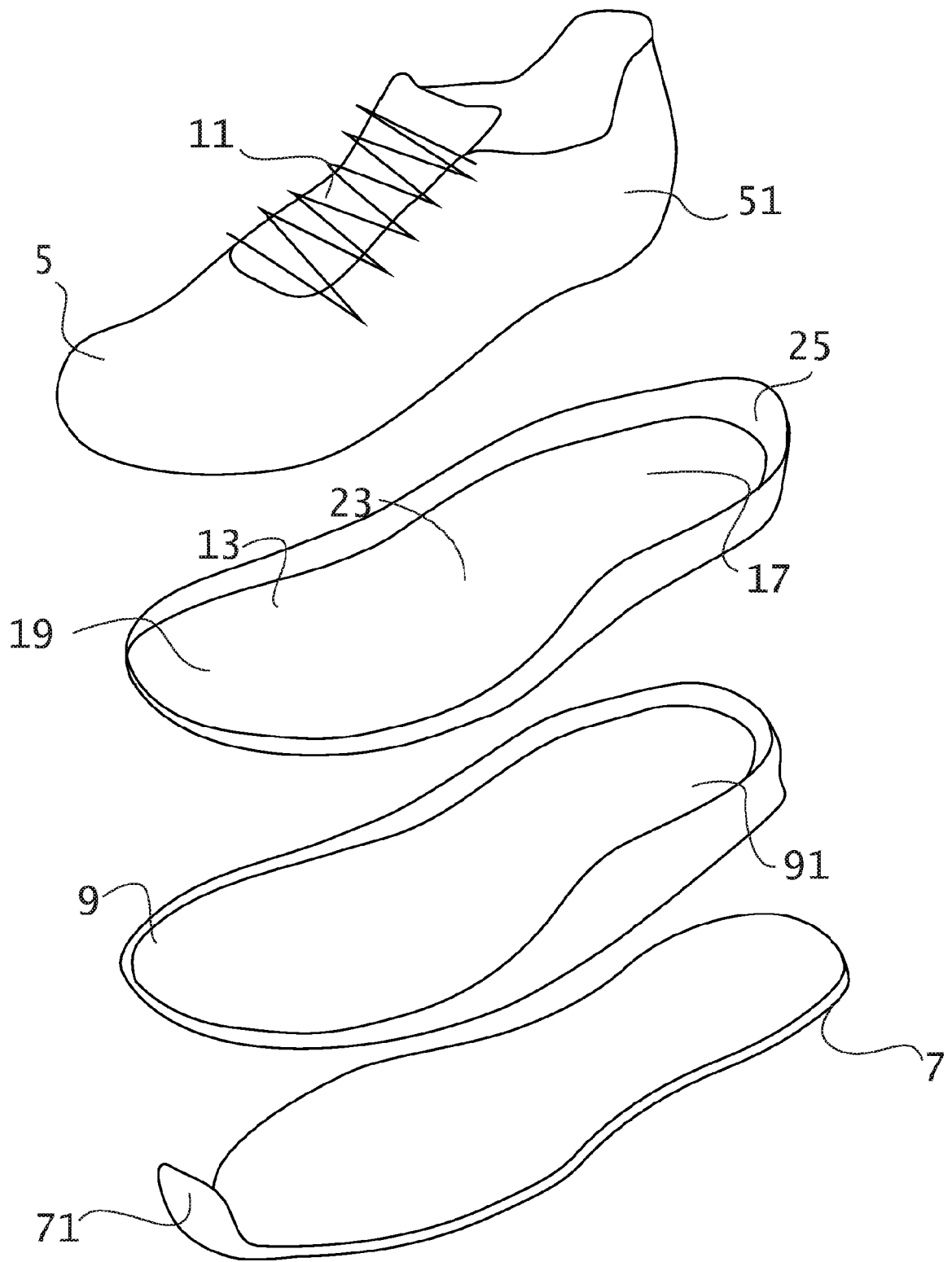
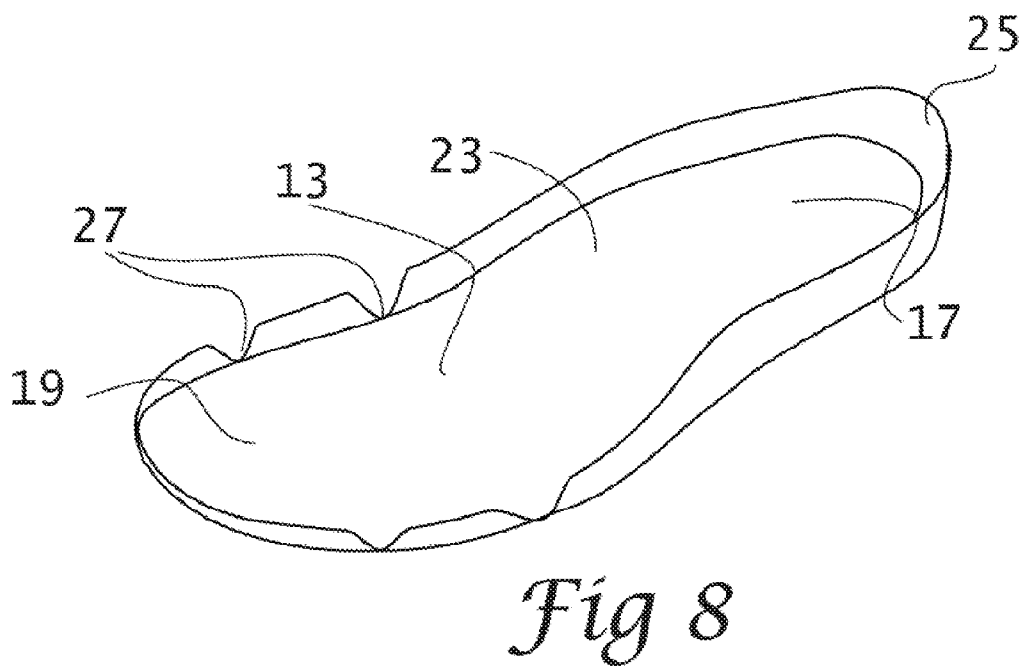
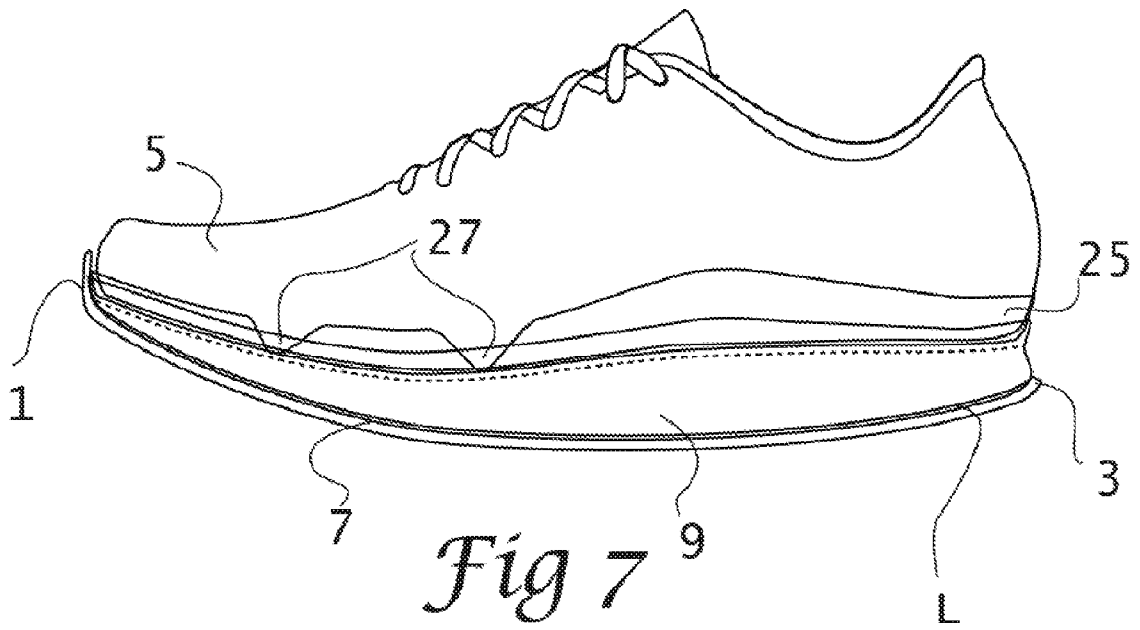
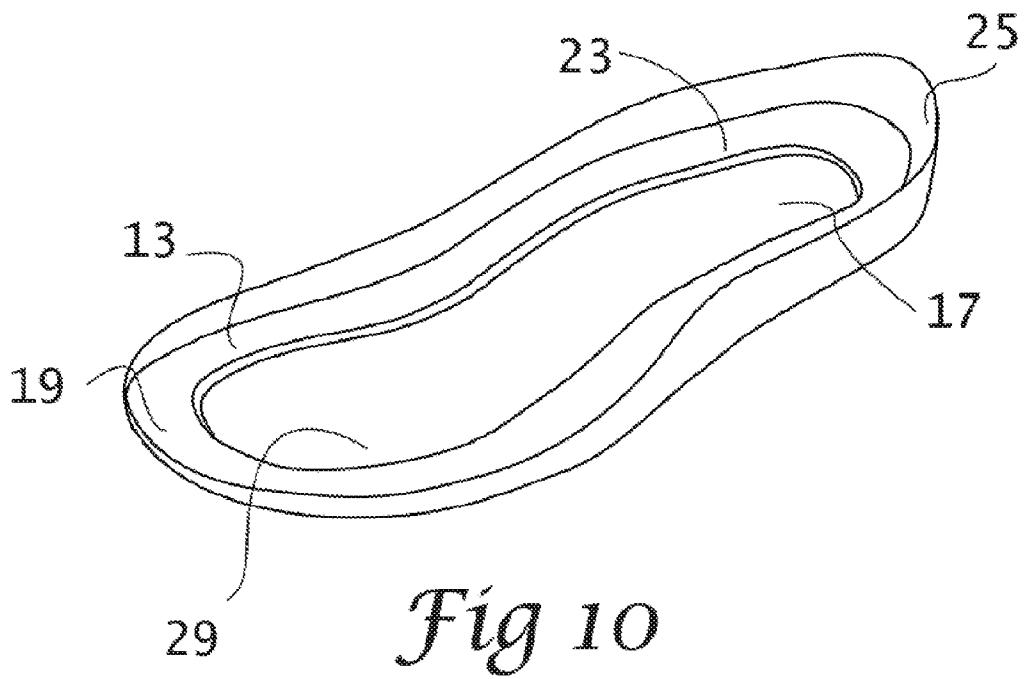
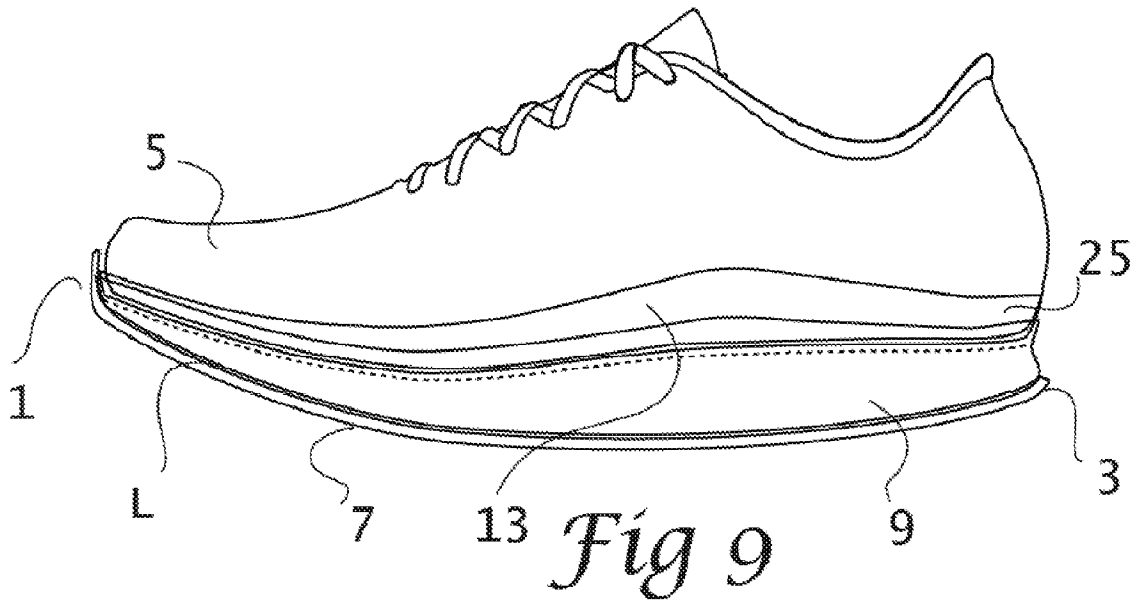

Fig 5





INTERNATIONAL SEARCH REPORT

International application No.

PCT/US2018/064292

A. CLASSIFICATION OF SUBJECT MATTER

IPC(8) - A43B 13/12; A43B 13/00; A43B 13/02; A43B 13/40 (2019.01)

CPC - A43B 13/127; A43B 13/00; A43B 13/02; A43B 13/026; A43B 13/12; A43B 13/125; A43B 13/40 (2019.02)

According to International Patent Classification (IPC) or to both national classification and IPC

B. FIELDS SEARCHED

Minimum documentation searched (classification system followed by classification symbols)

See Search History document

Documentation searched other than minimum documentation to the extent that such documents are included in the fields searched

USPC - 12/146B; 36/25R; 36/28; 36/30R; 36/73; 36/103; 36/107; 36/113 (keyword delimited)

Electronic data base consulted during the international search (name of data base and, where practicable, search terms used)

See Search History document

C. DOCUMENTS CONSIDERED TO BE RELEVANT

Category*	Citation of document, with indication, where appropriate, of the relevant passages	Relevant to claim No.
Y	US 2005/0262728 A1 (ROBBINS) 01 December 2005 (01.12.2005) entire document. See pg. 5 of ISA/237.	1-3
Y	US 2015/0089841 A1 (NIKE, INC.) 02 April 2015 (02.04.2015) entire document	1-3

Further documents are listed in the continuation of Box C.

See patent family annex.

* Special categories of cited documents:

"A" document defining the general state of the art which is not considered to be of particular relevance

"E" earlier application or patent but published on or after the international filing date

"L" document which may throw doubts on priority claim(s) or which is cited to establish the publication date of another citation or other special reason (as specified)

"O" document referring to an oral disclosure, use, exhibition or other means

"P" document published prior to the international filing date but later than the priority date claimed

"T" later document published after the international filing date or priority date and not in conflict with the application but cited to understand the principle or theory underlying the invention

"X" document of particular relevance; the claimed invention cannot be considered novel or cannot be considered to involve an inventive step when the document is taken alone

"Y" document of particular relevance; the claimed invention cannot be considered to involve an inventive step when the document is combined with one or more other such documents, such combination being obvious to a person skilled in the art

"&" document member of the same patent family

Date of the actual completion of the international search

31 January 2019

Date of mailing of the international search report

15 FEB 2019

Name and mailing address of the ISA/US

Mail Stop PCT, Attn: ISA/US, Commissioner for Patents
P.O. Box 1450, Alexandria, VA 22313-1450

Facsimile No. 571-273-8300

Authorized officer

Blaine R. Copenheaver

PCT Helpdesk: 571-272-4300
PCT OSP: 571-272-7774