



US00D944702S

(12) **United States Design Patent**
Li

(10) **Patent No.:** **US D944,702 S**

(45) **Date of Patent:** **** Mar. 1, 2022**

(54) **VEHICLE SIDE STEP**

(71) Applicant: **SHENZHEN SANGSHEN**
E-COMMERCE CO., LTD., Shenzhen
(CN)

(72) Inventor: **Chenghao Li**, Shenzhen (CN)

(73) Assignee: **SHENZHEN SANGSHEN**
E-COMMERCE CO., LTD., Shenzhen
(CN)

(**) Term: **15 Years**

(21) Appl. No.: **29/751,305**

(22) Filed: **Sep. 21, 2020**

(51) **LOC (13) Cl.** **12-16**

(52) **U.S. Cl.**
USPC **D12/203**

(58) **Field of Classification Search**
USPC D12/203, 98, 314, 162, 190, 196
CPC .. B60R 3/002; B60R 3/02; B60R 3/00; B60R
3/005; B60R 3/007
See application file for complete search history.

(56) **References Cited**

U.S. PATENT DOCUMENTS

D340,905 S *	11/1993	Orth, Sr.	D12/203
D568,222 S *	5/2008	Storer	D12/203
D658,559 S *	5/2012	Hodges	D12/203
D671,874 S *	12/2012	Kekich, Jr.	D12/203
8,641,068 B1 *	2/2014	Bundy	B60R 3/002 280/163
8,864,158 B1 *	10/2014	Perkins	B60R 3/002 280/163
D737,188 S *	8/2015	Perkins	D12/203
D757,622 S *	5/2016	Wolf	D12/203
D766,797 S *	9/2016	Li	D12/203

D789,858 S *	6/2017	Hare	D12/203
D809,446 S *	2/2018	Montoya	D12/203
D811,974 S *	3/2018	Guo	D12/203
D811,975 S *	3/2018	Guo	D12/203
D811,976 S *	3/2018	Wu	D12/203
D822,570 S *	7/2018	Li	D12/203
10,011,231 B1 *	7/2018	Wymore	B60R 3/002
D824,830 S *	8/2018	Wolf	D12/203
D829,626 S *	10/2018	Tang	D12/203
D847,716 S *	5/2019	Kim	D12/203
D858,400 S *	9/2019	Li	D12/203
D863,175 S *	10/2019	Wymore	D12/203
D864,068 S *	10/2019	Fichter	D12/203
D864,069 S *	10/2019	Fichter	D12/203
D886,019 S *	6/2020	Zhang	D12/203
D886,702 S *	6/2020	Guo	D12/203
D899,335 S *	10/2020	Li	D12/203

* cited by examiner

Primary Examiner — Michelle E. Wilson

Assistant Examiner — Clese Moore, Jr.

(57) **CLAIM**

The ornamental design for a vehicle side step, as shown and described.

DESCRIPTION

FIG. 1 is a perspective view of a vehicle side step showing my new design;

FIG. 2 is another perspective view thereof;

FIG. 3 is a front elevational view thereof;

FIG. 4 is a rear elevational view thereof;

FIG. 5 is a left side elevational view thereof;

FIG. 6 is a right side elevational view thereof;

FIG. 7 is a top plan view thereof; and,

FIG. 8 is a bottom plan view thereof.

The broken lines in the drawings depict portions of the vehicle side step that form no part of the claimed design.

1 Claim, 8 Drawing Sheets

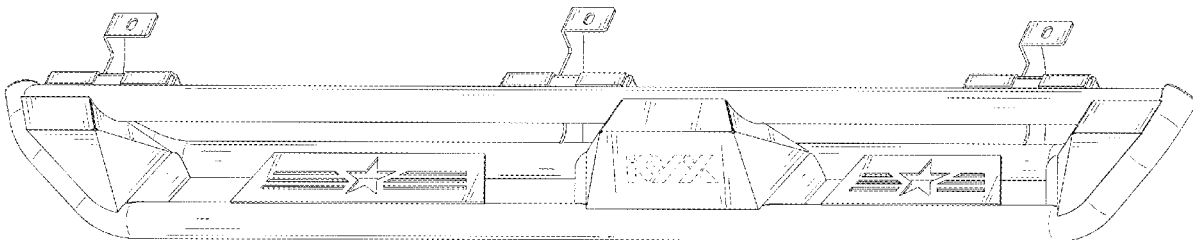

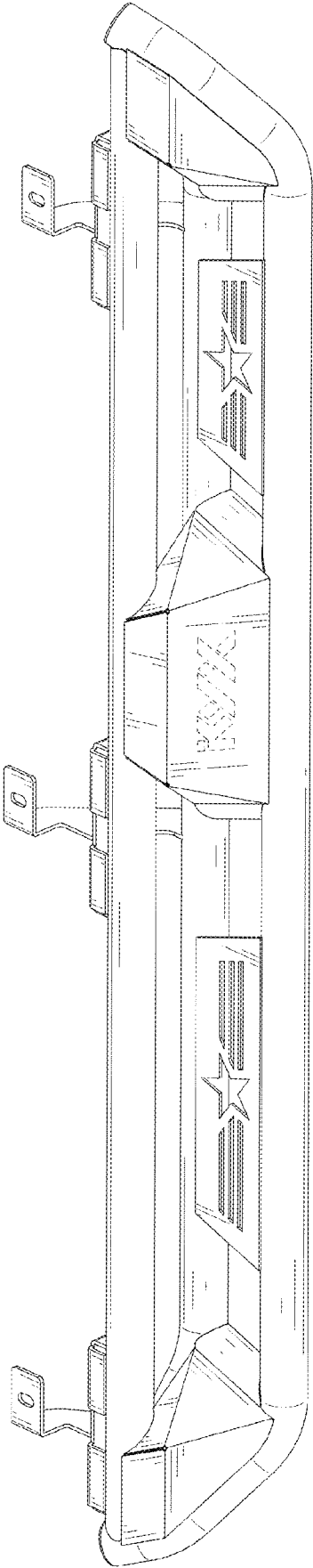

FIG. 1

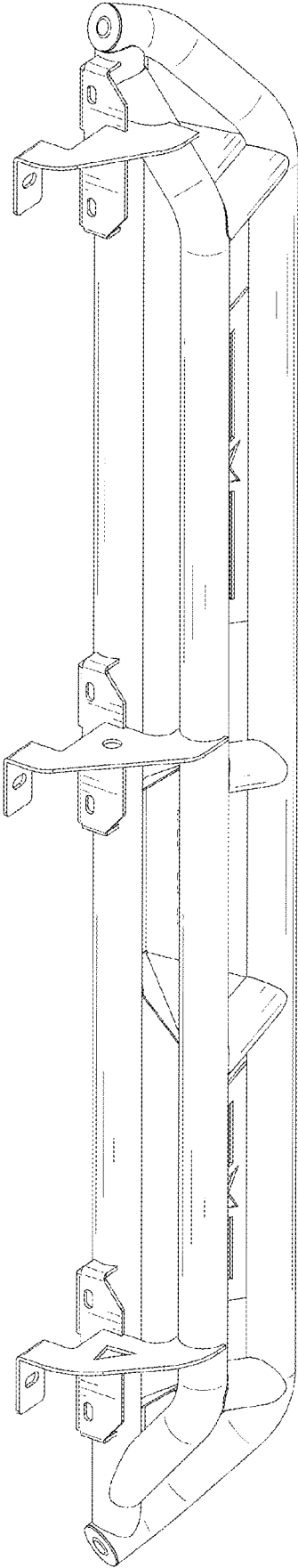

FIG. 2

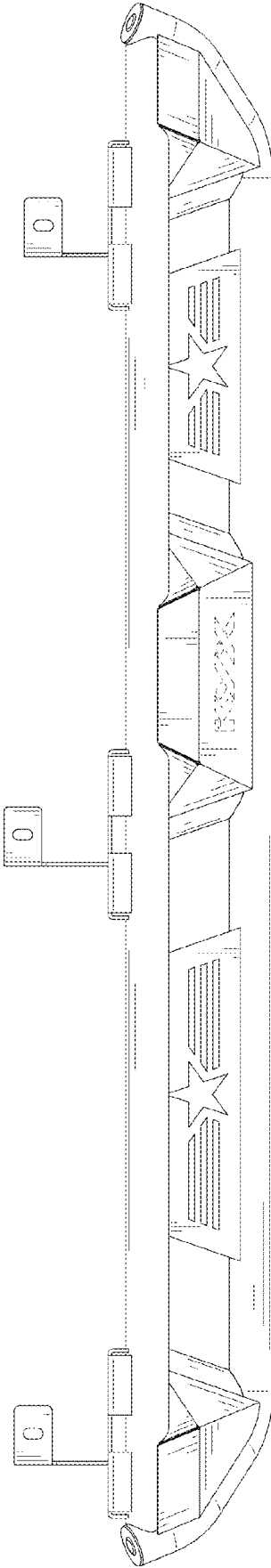

FIG. 3

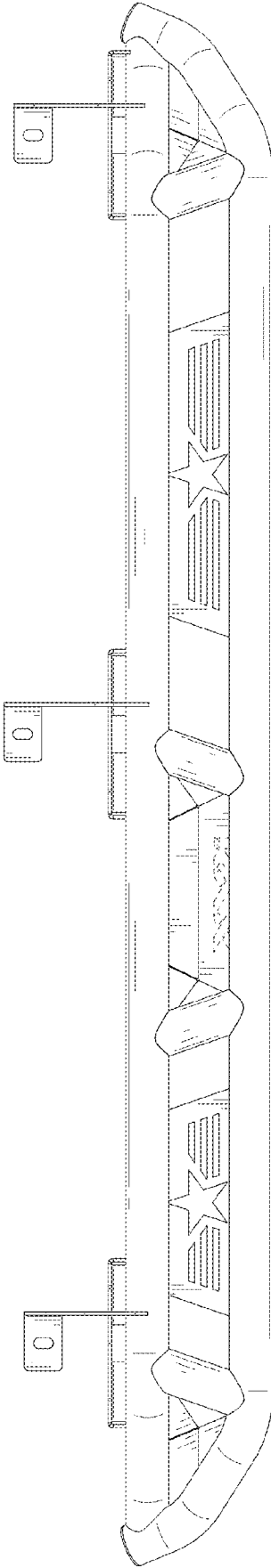

FIG. 4

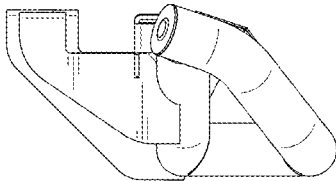

FIG. 5

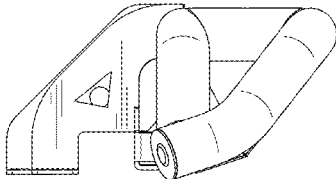

FIG. 6

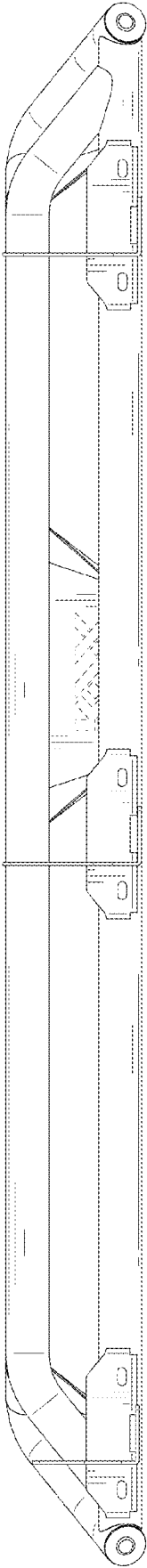

FIG. 7

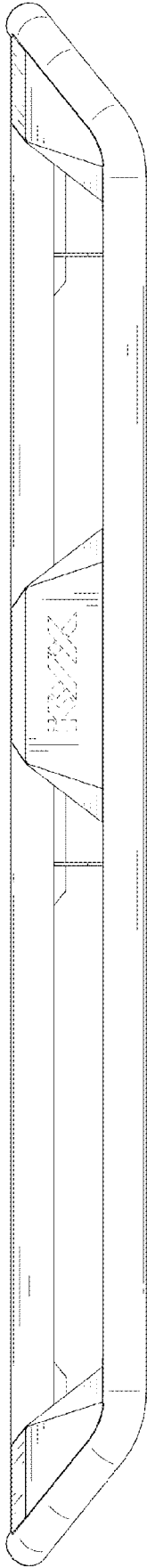

FIG. 8