

C. A. PARKER.
Brick Kiln.

No. 105,241.

Patented July 12, 1870.

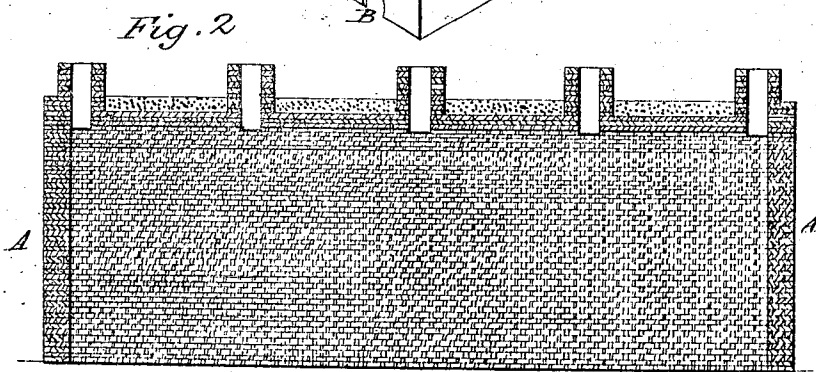
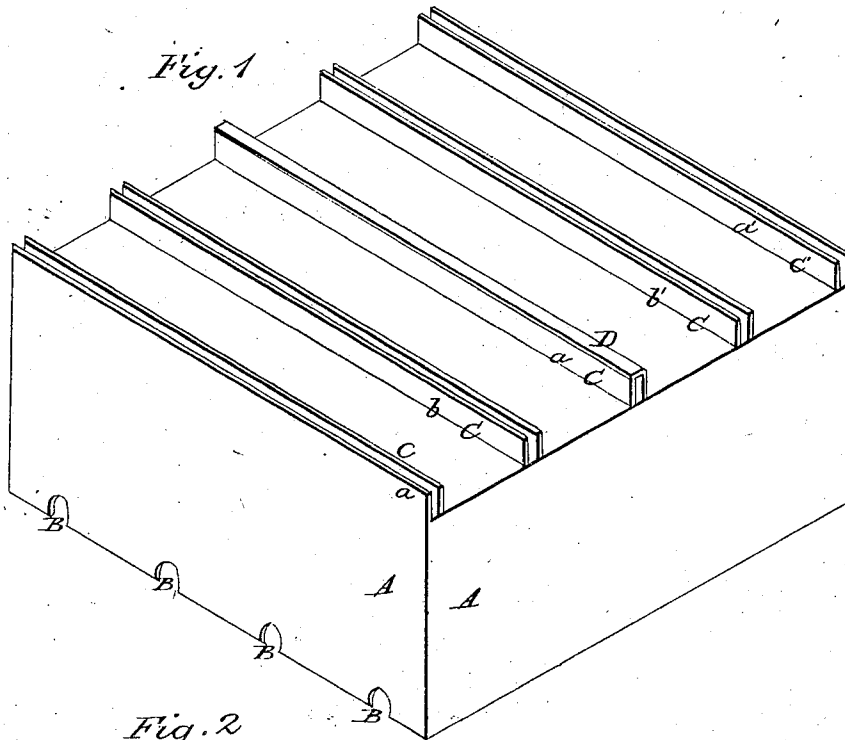

Witnesses:
H. M. Gaudin
R. P. Rhodes

Inventor:
Caleb A. Parker

United States Patent Office.

CALEB A. PARKER, OF NEW ORLEANS, LOUISIANA.

Letters Patent No. 105,241, dated July 12, 1870.

IMPROVED BRICK KILN.

The Schedule referred to in these Letters Patent and making part of the same

I, CALEB A. PARKER, of the city of New Orleans and State of Louisiana, have invented a certain new and useful Improvement in Brick-Kilns, of which the following is a specification.

The nature of my invention consists in a peculiar method of constructing brick-kilns, by which I secure an equal distribution of heat throughout all parts of the kiln, when such distribution is desirable, or to concentrate it in any particular part thereof, at pleasure, and hence effect the equal or uniform burning of every brick in it; to increase the height of the kiln, and thus to economize ground space, and largely to reduce the cost of burning any given number of bricks.

In a general way, it may be said that all these desirable objects are accomplished by the utilization or application of all or nearly all the heat that is evolved in the combustion of the fuel employed to burn a kiln of any given size; but, in strictness of language, the economic ends only, to wit, the reduction of space, fuel, and the cost of burning, are secured by the utilization and application of the whole heat, while the uniform burning of the bricks everywhere throughout the kiln is more literally effected by the power which my mode of construction gives to me of throwing into and concentrating the heat at any part of the kiln, even up to its very walls, and from the tops to the bottoms thereof.

My invention consists of a combination of parallel lines of flues or smoke-stacks for the escape of the products of combustion, that are provided with removable and adjustable covers, with a covering of sand, or other equivalent non-conducting substance, between them of sufficient thickness to prevent the loss of any appreciable part of the heat that is produced to burn the kiln, the flues, with their covers, enabling me to control and direct the heat and flame to any part of the kiln, and there to concentrate it, while the covering of sand prevents the escape of the heat everywhere except where the flues are open.

My invention will be at once understood by referring to the drawing, whereon my improved kiln is shown at—

Figure 1, in perspective, and at

Figure 2 by a cross-section on line *a b* of fig. 1.

On the drawing—

A marks the walls of a kiln, which may be of any usual and approved construction, and

B, the arches or clamps to receive the fuel, and over which the bricks to be burned are set in any suitable manner, which will allow of a free circulation of the heat and flame throughout all parts of the kiln.

As kilns are now constructed, they are seldom carried higher than thirty-six tiers of bricks, but in kilns constructed on my plan fifty or more tiers may safely be bestowed therein, and with absolute certainty that

all will be burned to a uniform degree of hardness; but whatever the size of the kiln or its vertical elevation, the walls *A* must be somewhat higher or above the upper tier of bricks, in order to prevent the escape of the non-conducting loose covering of sand or other equivalent substance.

After the bricks are set in the kilns as high as desired in any given case, I raise above the mass two feet or more, lines of flues or small smoke-stacks, *C*, parallel to each other, and distant from each other from three to eight feet.

Each of these flues is provided with a removable cover, *D*, that is so constructed that it may be moved endwise, and thus open the flue at either end, as may be desired. By removing the cover the whole flue is opened.

Between the flues *D*, I put, on the top of the kiln, two layers of bricks, that are laid as close to each other as possible, and in such manner that the first or lower layer will break the joints of the upper tier of bricks to be burned, and the second or upper tier joints of the first or lower layer. I then put on a covering of sand, or some other equivalent substance, from six to eight inches thick, and the kiln is ready for burning.

On starting the fires, all the flues are closed by their covers, except the two outer lines *a a*, in order to deflect and force the flame and heat against the sides immediately beneath them, and through the bricks that lie against the walls on those sides and proximately thereto.

As soon as the bricks along these walls and in the line of the heat as it passes from the arches to these flues are sufficiently burned, which fact is determined by the change of color of the escaping flame and the disappearance of the water smoke, or through the mica-covered openings in the walls, these outside flues are closed by putting their covers on them, and the next two lines *b b* are opened and kept so, until the bricks that come within the range of the now deflected currents of heat are, in their turn, seen by the same change of color and disappearance of water smoke in the flame, to be also sufficiently burned.

If it should happen that the evidences of a complete burning do not show themselves throughout the whole length of these flues or either of them, the cover or covers, as the case may be, are put on so as to close the opening wherever the flame has changed to the proper color, so as to force the heat through the bricks underlying the other portions or portion of the said openings or opening. This will quickly restore or establish the desired equilibrium as to the degree of burning.

The burning of the kiln after the side flues *a a* are closed will proceed much more rapidly than before, be-

cause the radiated heat thrown out in the burning of the bricks in contact with and near the walls, will have already driven off a considerable measure of moisture from every part of the mass of bricks that compose it. If, as shown on the drawing, there are only five flues, the central one, *d*, is the last opened, the flues *b b'* being at the same time closed.

No additional fuel is required after the central flue is opened, no matter how many flues there may be in the kiln, because the intense heat which now pervades all parts of the kiln, except in that part which is under that central flue, being deflected and thrown into the center of the kiln, will, in an incredibly short space of time, complete the burning without additional fuel.

In order to prevent the cracking of the bricks from too sudden a cooling and contraction after the burning is effected, it will be necessary to keep the covers on all the flues for a few days, and then to remove them gradually, or one at a time, by slipping them sidewise off the top of the flues.

My invention makes it unnecessary ever to pack in fuel into the arches or clamps, commonly so called, from the beginning to the end of the operation of burning, as in the case of kilns of ordinary construction, hence there can be no "choking" of the kiln from this cause.

The arches *B* are all provided with doors, which are kept constantly closed, except when opened to receive fuel. This being the case, there is no waste of heat, except through the flues that, for the time being, are open, and, consequently, a far less quantity of fuel is

required than in ordinary kilns, to burn any given number of bricks.

I have, in fact, demonstrated by actual experiment that less than half the fuel is required to burn a given number of bricks in a kiln constructed on my plan, as herein described, than in any other kiln of which I have any knowledge. I have found also that every brick in the kiln is burned to precisely the same degree of hardness, which, it is well known, is never the case in ordinary kilns. The bricks over the arches are also saved, because, being filled with fuel, the arches are not injured by the violent throwing of the fuel against the bricks of which they are formed.

Either coal or wood may be used as fuel, for the arches, being closed, and the air to support combustion entering underneath the same, and below the grates, there is always so powerful a draught that very inferior qualities of both coal and wood may be burned in the most rapid manner.

I claim as my invention—

Constructing brick-kilns so as to provide parallel flues, *C*, when the spaces between the same above the bricks to be burned are filled with a covering of two layers of bricks, laid as herein described, on which is placed a superstratum of sand, or its equivalent, for the purpose set forth.

CALEB A. PARKER

Witnesses:

H. N. JENKINS,
RUFUS R. RHODES.