



Europäisches Patentamt
European Patent Office
Office européen des brevets



(11) **EP 0 705 546 B1**

(12) **EUROPEAN PATENT SPECIFICATION**

(45) Date of publication and mention
of the grant of the patent:
24.08.2005 Bulletin 2005/34

(51) Int Cl.7: **A45D 26/00**

(21) Application number: **95117823.5**

(22) Date of filing: **19.02.1992**

(54) **Depilating device**

Enthaarungsvorrichtung

Dispositif à épiler

(84) Designated Contracting States:
DE FR GB IT

(30) Priority: **20.02.1991 JP 2610491**
25.06.1991 JP 15278691
20.12.1991 JP 33855991

(43) Date of publication of application:
10.04.1996 Bulletin 1996/15

(62) Document number(s) of the earlier application(s) in
accordance with Art. 76 EPC:
92102760.3 / 0 500 075

(73) Proprietor: **MATSUSHITA ELECTRIC WORKS,**
LTD.
Osaka 571 (JP)

(72) Inventors:

- **Iwasaki, Juzaemon, c/o Matsushita Electric**
Osaka (JP)
- **Tanahashi, Masao, c/o Matsushita Electric**
Osaka (JP)
- **Sueyoshi, Hidekazu, c/o Matsushita Electric**
Osaka (JP)

(74) Representative: **Goddar, Heinz J.**
FORRESTER & BOEHMERT
Pettenkoferstrasse 20-22
80336 München (DE)

(56) References cited:
EP-A- 0 463 936
US-A- 4 960 422

DE-A- 4 117 480

EP 0 705 546 B1

Note: Within nine months from the publication of the mention of the grant of the European patent, any person may give notice to the European Patent Office of opposition to the European patent granted. Notice of opposition shall be filed in a written reasoned statement. It shall not be deemed to have been filed until the opposition fee has been paid. (Art. 99(1) European Patent Convention).

Description

TECHNICAL FIELD

[0001] The present invention is directed to a depilating device for removing superfluous hairs from the skin for aesthetic reasons or the like, comprising the features of the preamble of claim 1.

[0002] Depilating devices are known, for example, in Japanese patent publication JP-B-7079731 and in European Patent Specification No. 0,328,426. The devices of these patents disclose the use of a series of pinching disks supported on a shaft. Each alternate disk is driven to move in one direction at a time along an axis of the shaft in order to clamp hairs between the two adjacent disks for plucking the hairs from the user's skin. However, the prior art devices cause users pain.

[0003] The above problem has been eliminated in an improved depilating device of the present invention. The depilating device in accordance with the present invention is characterized by the features of the characterising portion of claim 1.

[0004] The structure of the depilating device according to the present invention is based upon finding that pulling the hairs along its direction or the orientation of the pores in the skin can well reduce the pain. With this structure, it is readily possible to catch the hairs by moving the blades along the hair in the forward swinging stroke, after which the hairs can be successfully pulled along the length of the hairs in the return stroke of the blades.

[0005] These and still other objects and advantageous features of the present invention will become more apparent from the following description of the preferred embodiments when taken in conjunction with the attached drawings.

BRIEF DESCRIPTION OF THE DRAWINGS

[0006]

Fig. 1 is a perspective view of a depilating device in accordance with a first embodiment of the present invention;

Fig. 2 is a vertical section of the depilating device;

Fig. 3 is a vertical section taken along line I-I of fig. 2;

Fig. 4 is a vertical section taken along line II-II of fig. 2;

Figs. 5A to 5E are vertical sections illustrating the oscillating movement of a plucking assembly of the depilating device;

Figs. 6A to 6E are explanatory views illustrating the clamping operations of movable pinching plates in correspondence respectively to figs. 5A to 5E;

Fig. 7 is an explanatory view illustrating the clamping operation of the movable pinching plate with the corresponding fixed pinching plates;

Fig. 8 is an explanatory view illustrating another

clamping operation in accordance with a modification of first embodiment;

Fig. 9 is a perspective view of a depilating device in accordance with a second embodiment of the present invention;

Fig. 10 is a vertical section of the depilating device; Fig. 11 is a vertical section taken along line III-III of fig. 10;

Fig. 12 is a vertical section taken along line IV-IV of fig. 10;

Figs. 13A to 13E are vertical sections illustrating the oscillating movement of a plucking assembly of the depilating device;

Figs. 14A to 14E are explanatory views illustrating the clamping operations of movable pinching plates in correspondence respectively to figs. 13A to 13E; and

Fig. 15 is an expanded view of the positive-return cam shown with the clamping operations of the movable pinching plates effected at points of the X-shaped grooves.

DESCRIPTION OF THE EMBODIMENTS

25 First Embodiment <Figs. 1 to 8>

[0007] Referring now to fig. 1, there is shown a depilating device in accordance with a first embodiment of the present invention. The device comprises a housing 10 and a depilator head 20 mounted on the upper end of the housing 10 to surround a plucking assembly 40 which is responsible for removing the hairs from the skin. The housing 10 is composed of housing halves and incorporates an electric motor 70 for driving the plucking assembly 40. The motor 70 is supported by a chassis 60 together with an associated mechanism for driving the plucking assembly 40. The housing 10 is provided with a power switch 13 for energization of the motor 70 directly from an AC main power or through an incorporated rechargeable battery. A socket terminal 14 is provided in the lower end of the housing 10 for electrical connection to an AC power adaptor for charging the battery and energizing the motor 70. The depilating head 20 is provided in the form of a rectangular head frame with a pair of end walls which define therebetween an opening 23 for receiving therein the plucking assembly 40.

[0008] The depilating head 20 is detachably mounted on the upper end of the housing 10 by means of a hook 15 and carries a hair smoothing guide 30 which comes into contact with the skin of the user for smoothing the hairs prior to plucking the hairs by the plucking assembly 40. The guide 30 is of a rather flat rectangular configuration with a pair of side bars extending in parallel with the side walls of the head 20. The guide 30 is disposed within the upper end of the opening 23 and connected to a pair of pins on the end walls of the head 20 so as to swivel about the pins for easily

following the contour of the skin when moving the head 20 across the skin of the user. For smoothing purposes, the guide 30 is formed on one of the side bars with comb projections 31 and is also provided with a roller 32 extending above the other side bar and freely rotatable about corresponding pins 33 supported by the guide 30.

[0009] The plucking assembly 40 comprises a carrier 41 rotatably supported about a shaft 42 extending horizontally between the end walls of the head 20 with its opposite ends journaled to the upper end of the chassis 60. The carrier 41 is provided with a series of fixed pinching plates 43 of somewhat semi-circular configuration arranged along the axis of the shaft. The fixed pinching plates 43 are made of a plastic material showing some elasticity and are molded integrally with the carrier 41 to provide a unitary structure. However, the fixed pinching plates 43 may be separately formed from the carrier 41. Also mounted on the carrier 41 are movable pinching plates 44 which are arranged along the axis of the shaft 42 in an alternating relation to the fixed pinching plates 43. The movable pinching plates 44 are composed of first and second plates 44A and 44B which are commonly supported loosely on the shaft 42 to be rotatable thereabout together with the carrier 41 and the fixed pinching plates 43. The first and second plates 44A and 44B are arranged along the axis of the shaft 42 alternately to each other and are secured at their lower ends respectively to first and second sliders 50A and 50B which are slidably supported by axles 52 held in the lower end of the carrier 41 and which are driven to reciprocate in parallel with the shaft 42 but in the opposite directions to each other, as will be discussed later.

[0010] Turning back to fig. 2, the chassis 60 supports, in addition to the motor 70, a positive, return cam 80 and a plurality of gears for establishing a drive connection from the motor 70 to the positive-return cam 80 as well as for oscillating the carrier 41 or the plucking assembly 40 about the shaft 42. The positive-return cam 80 is provided in the form of a cylinder with a pair of circumferentially extending grooves 81 which are symmetrical to each other such that the horizontal distance between the grooves varies in the circumferential direction. The cam 80 is supported on a horizontally extending center shaft 82 to be rotatable therewith and is operatively connected at the grooves 81 to the sliders 50A and 50B by means of universal joints. Each joint comprises a vertical swivel 91 and a horizontal swivel 92 which is inserted into a top plate 61 of the chassis 60 to be freely rotatable therein.

[0011] The motor 70 is operatively connected to the positive-return cam 80 through a reduction gear train of a pinion 71 of the motor 70, a first gear 72 on a first shaft 73, a second gear 74 on a second shaft 75, a third gear 83 on one end of the shaft 82 of the positive-return cam 80. The first and second shafts 73 and 75 are held in the chassis 60 in a parallel relation to the shaft 42. A cam 63 is carried on one end of the second shaft 75

opposite to the second gear 74 so as to be rotatable therewith and is provided with an eccentric pin 64 which is eccentric to the axis of the second shaft 75 and which is connected to one end of a crank lever 65. The other end of the crank lever 65 is connected to a gear wheel 66 by means of a pivot pin 67 at a point radially outwardly of a shaft 68 carrying the gear wheel 66. As best shown in fig. 4, the gear wheel 66 is in meshing engagement with a gear 49 on one end of the shaft 42 of the carrier 41 so that the rotation of the eccentric pin 64 about the second shaft 75 is translated into an oscillating rotary movement of the gear wheel 66 about the shaft 68 and therefore the corresponding movement of the gear 49 or the plucking assembly 40 about the shaft 42. That is, the plucking assembly 40 is caused to oscillate about the shaft 42 in synchronism with the above-described plucking movement of displacing the movable pinching plates 44 in the axial direction of the shaft 42, and is so arranged to complete one oscillation cycle while the positive-return cam 80 rotates one-half about the center shaft 82 such that the movable pinching plate 44 is caused to move toward and away from one of the two adjacent fixed pinching plates 43 during one oscillation cycle of the plucking assembly 40 about the shaft 42 and to move toward and away from the other fixed pinching plate 43 during and away from the other fixed pinching plate 43 during subsequent one oscillation cycle of the plucking assembly 40.

[0012] The operation of the plucking assembly 40 will be now discussed with reference to figs. 5A to 5E and 6A to 6E which illustrate in sequence one oscillation cycle of the plucking assembly 40 about the shaft 42. When the plucking assembly 40 is in a position of fig. 5A, the upper edge of the movable pinching plate 44 is angularly displaced downward to be hidden within the opening 23 of the depilator head 20 and at the same time the movable pinching plate 44 is kept in a neutral position where the upper edge thereof is spaced axially along the shaft 42 from both of the two adjacent fixed pinching plates 43, as shown in fig. 6A. As the plucking assembly 40 rotates in a clockwise direction in the figure about the shaft 42 from the position of fig. 5A to a position of fig. 5B to rotate the movable pinching plates 44 for exposure into the opening 23 of the depilator head 20 while advancing the head 20 along the user's skin in the direction indicated by an arrow A in the figures, the movable pinching plate 44 is still kept in spaced relation to the two adjacent fixed pinching plates 43, shown in fig. 6B, so as to be ready for entrapping the hair H into a clearance between the movable pinching plate 44 and the fixed pinching plate 43. When the plucking assembly 40 is rotated further to the position of fig. 5C while being further advanced in the direction of the arrow A, the movable pinching plate 44 is caused to axially shift to have its upper end engaged with one of the two adjacent fixed pinching plates 43 to clamp the hair H therebetween, as shown in fig. 6C. Thereafter, the plucking assembly 40 is caused to rotate in the reverse direction, i.e., counter-

clockwise direction in the figure to a position of fig. 5D, at which condition, the movable pinching plate 44 is kept in closed relation to the correspondirig fixed pinching plate 43 so as to keep clamping the hair H therebetween, as shown in fig. 6D, to thereby pull and remove the hair H from the skin as the plucking assembly 40 rotates about the shaft 42. Subsequently, when the plucking assembly 40 is further rotated in the counter-clockwise direction to return to a position of fig. 5E which is the same position of fig. 5A, the movable pinching plate 44 is caused to move away from the fixed pinching plate 43 and returns into the neutral position, during which the hair H is released and flew circumferentially out of the plucking assembly 40 by a centrifugal force acting thereon. In summary, the hairs are removed along their length or directions by moving the blades along the hair in the forward swinging stroke and following pulling it along its length in the return stroke of the blades.

[0013] At this time, the positive-return cam 80 has completed one-half rotation so that, in the immediately subsequent one oscillation cycle of the plucking assembly 49 or in subsequent one-half rotation of the cam 80, the movable pinching plate 44 is caused to move toward and away from the other fixed pinching 43 so as to cooperate therewith for effecting the like plucking operation. In this manner, each movable pinching plate 44 is caused to move axially along the shaft 42 between the two adjacent fixed pinching plates 43 to clamp the hair with the one fixed pinching plate 43 at a time and the hair with the other fixed pinching plate 43 at the other. Thereby, a whole distance between the two adjacent fixed plates 43 can be best utilized as an effected plucking length. It should be noted here that, since the set of alternate movable punching plates 44A and the other alternate set of the movable pinching plates 44B are caused to move in the opposite direction along the shaft 42, the two adjacent movable pinching plates 44A and 44B are simultaneously brought into abutment against the one common fixed pinching plate 43 positioned therebetween to apply counterbalancing forces F to the fixed pinching plate 43 at a time, as shown in fig. 7, thus canceling otherwise occurring undesired vibrations of the fixed pinching plates 43 and therefore minimizing the operation noise. Although the first embodiment discloses to arrange the movable pinching plates 44 in an alternating relation to the fixed pinching plates 43, as shown in fig. 7, it is equally possible to arrange the two movable pinching plates 44A and 44B between the two adjacent fixed pinching plates 43, as shown in fig. 8, while effecting to apply counterbalancing forces F to the common fixed pinching plate 43 from the adjacent two movable pinching plates 44A and 44B.

Second Embodiment <FIGS. 9 to 14>

[0014] Referring to figs. 9 to 14, there is shown a depilating device in accordance with a second embodi-

ment of the present invention. The device comprises a depilator head 120 mounted on a housing 110 and including a plucking assembly 140. The housing 110 incorporates a chassis 160 mounting a motor 170, a positive return cam 180, and a drive mechanism for the plucking assembly 140. The housing 110 is provided with a switch handle 113 for turning on and off the motor 170 and also with a pair of terminal pins 114 for electrical connection to an AC power adaptor to energize the motor 170. The head 120 is in the form of a top and bottom opened rectangular frame having a pair of end walls between which the plucking assembly 140 is received. The head 120 is detachably mounted on the upper end of the housing 110 by means of a hook 115 and carries a hair smoothening guide 130 which comes into contact with the skin of the user for smoothening the hairs prior to plucking the hairs by the plucking assembly 140. A head cap 128 is provided to fit over the head 120 for protection thereof when not in use. The guide 130 is of a rather flat rectangular configuration with a pair of side bars extending in parallel with the side walls of the head 120 and a pair of opposed end bars with center dents. The front side bar is slotted to give a comb projection 131 for smoothening the hairs, while the rear side bar carries a roller 132 in rolling contact with the user's skin for facilitating to move the cutter head 120 across the skin. The roller 132 is supported to be rotatable about a pin journaled at the opposite ends to the rear side bar.

[0015] The plucking assembly 140 employed in the second embodiment is identical to that of the first embodiment. Therefore, no further explanation is deemed necessary but it is repeated here that the assembly 140 includes a like carrier 141 rotatably supported on a shaft 142 and mounting a number of fixed pinching plates 143 alternated by movable pinching plates 144 and that the movable pinching plates consist of first and second plates 144A and 144B which are commonly supported loosely on the shaft 142 to be rotatable thereabout together with the carrier 141 and the fixed pinching plates 143. The first and second plates 144A and 144B are secured at their lower ends respectively to first and second sliders 150A and 150B which are slidably supported by axles 152 held in the lower end of the carrier 141 and which are driven to reciprocate in parallel with the shaft 142 but in the opposite directions to each other. A roller 195 is slidably received in an arcuate furrow 153 formed in the bottom of each of the sliders 150A and 150B. A side projection receives an offset pin 196 which extends in parallel with the center vertical shaft 193 in an opposite relation to the eccentric pin 194 from the center vertical shaft 193. Provided at the lower end of each offset pin 196 is a cam follower 197 for slidable engagement into each one of grooves 181 of the positive-return cam 180 such that the rotation of the cam 180 is translated into reciprocating movement of the sliders 150A and 150B along the shaft 142 through a swinging movement of the cam cylinders 190, thereby displacing the movable pinching plates 144A and 144B in the axial direction

to move their upper edge into abutment and away from the associated fixed pinching plates 143.

[0016] The positive-return cam 180 is provided in the form of a cylinder supported on a horizontally extending center shaft 182 to be rotatable therewith. The cam 180 is formed with a axially spaced pair of circumferentially extending grooves 181 which are symmetrical to each other such that the horizontal distance between the grooves 181 varies in the circumferential direction.

[0017] The operation of the plucking assembly 140 will be now discussed with reference to figs. 13A to 13E and 14A to 14E which illustrate in sequence one oscillation cycle of the plucking assembly 140 about the shaft 142. When the plucking assembly 140 is in a position of fig. 13A, the upper edge of the movable pinching plate 144 is angularly displaced downward to be hidden within the opening 123 of the depilator head 120 and at the same time the movable pinching plate 144 is kept in a neutral position where the upper edge thereof is spaced axially along the shaft 142 from both of the two adjacent fixed pinching plates 143, as shown by solid lines in fig. 14A. It is noted here that dotted lines in figs. 14A to 14E show the positions of the same movable pinching plate 144 taken during the next oscillation cycle of the plucking assembly 140. As the plucking assembly 140 rotates in a counter-clockwise direction in the figure about the shaft 142 from the position of fig. 13A to a position of fig. 13B to rotate the movable pinching plates 144 for exposure into the opening 123 of the depilator head 120 while advancing the head 120 along the user's skin in the direction indicated by an arrow A in the figures, the movable pinching plate 144 is still kept in spaced relation to the two adjacent fixed pinching plates 143, as shown in fig. 14B, so as to be ready for entrapping the hair H into a clearance between the movable pinching plate 144 and the fixed pinching plate 143. When the plucking assembly 140 is rotated further to the position of fig. 13C while being further advanced in the direction of the arrow A, the movable pinching plate 144 is caused to axially shifted to have its upper edge engaged with one of the two adjacent fixed pinching plates 143 to clamp the hair H therebetween, as shown in fig. 14C. Thereafter, the plucking assembly 140 is caused to rotate in the reverse direction, i.e., clockwise direction in the figure to a position of fig. 13D, at which condition, the movable pinching plate 144 is kept in closed relation to the corresponding fixed pinching plate 143 so as to keep clamping the hair H therebetween, as shown in fig. 14D, to thereby pull and remove the hair H from the skin as the plucking assembly 140 rotates about the shaft 142.

[0018] Subsequently, when the plucking assembly 140 is further rotated in the clockwise direction to return to a position of fig. 13E which is the same position of fig. 13A, the movable pinching plate 144 is caused to move away from the fixed pinching plate 143 and returns into the neutral position, during which the hair H is released and flew circumferentially out of the plucking assembly

140 by a centrifugal force acting thereon. In summary, once again the hairs are removed along their length or directions by moving the blades along the hair in the forward swinging stroke and following pulling it along its length in the return stroke of the blades.

[0019] At this time, the positive-return cam 180 has completed one rotation so that, in the immediately subsequent one oscillation cycle of the plucking assembly 140 or subsequent one rotation of the cam 180, the movable pinching plate 144 is caused to move toward and away from the other fixed pinching 143, as shown in the dotted lines of figs. 14A to 14E, so as to cooperate therewith for effecting the like plucking operation.

[0020] The features disclosed in the foregoing description, in the claims and/or in the accompanying drawings may, both, separately and in any combination thereof, be material for realizing the invention in diverse forms thereof.

20 LIST OF REFERENCE NUMERALS

[0021]

10	housing
25	13 power switch
	14 socket terminal
	15 hook
	20 depilator head
30	23 opening
	30 hair smoothing guide
	31 comb projection
	33 pin
35	40 plucking assembly
	41 carrier
	42 shaft
	43 fixed pinching plate
40	44 movable pinching plate
	45 hole
	49 gear
	50 slider
45	52 axle
	60 chassis
	61 top plate
	63 cam
50	64 eccentric pin
	65 crank lever
	66 gear wheel
	67 pivot pin
	68 shaft
55	
	70 motor
	71 pinion
	72 first gear

73 first shaft
 74 second gear
 75 second shaft

 80 positive-return cam
 82 center shaft
 83 third gear

 110 housing
 111 housing half
 112 housing half
 113 power switch
 114 terminal pin
 115 hook
 119 boss

 120 depilator head
 123 opening
 124 pin
 128 head cap

 130 hair smoothening guide
 131 comb projection
 132 roller

 140 plucking assembly
 141 carrier
 142 shaft
 143 fixed pinching plate
 144 movable pinching plate
 145 hole
 146 anchor leg
 147 side tab
 148 groove
 149 gear

 150 slider
 151 notch
 152 axle
 153 furrow

 160 chassis
 161 top plate
 169 screw

 170 motor
 171 pinion
 172 first gear
 173 first shaft

 180 positive-return cam
 181 groove
 182 center shaft
 183 second gear

 190 cam cylinder
 191 barrel
 193 center vertical shaft

5
 10
 15
 20
 25
 30
 35
 40
 45
 50
 55

Claims

1. A depilating device for removing hairs from the skin of a user comprising;
 - a housing (10; 110) with a top opening (23; 123);
 - a carrier (41) mounted in said housing and having a longitudinal axis and mounting a series of fixed and movable pinching plates (43, 44; 143, 144) arranged along an axial direction of said carrier to define small clearances between the respective tips of the adjacent plates for entrapping the hairs therebetween;
 - shuttle means (50A, 50B; 150A, 150B) coupled to said movable pinching plates for displacing said movable pinching plates along said longitudinal axis to repeatedly clamp the hairs between the tips of the adjacent plates, and subsequently release the hairs;

characterized in that

said device includes drive means (65, 66, 49; 165, 166, 149) coupled to said plurality of pinching plates (43, 44; 143, 144) for reciprocating said pinching plates along an arcuate path about said longitudinal axis between an extended position where the tips of the plates reach said opening (23; 123) in engageable relation to the hairs on the skin and an retraced position, where the tips of the plates are retracted in the housing away from said opening; said drive means is cooperative with said shuttle means during reciprocating such that said pinching plates are closing for clamping the hair during the movement of the tips along said arcuate path from the most retracted position to the most extended position and is initially kept closed during movement in the reverse direction from said most extended position to said most retracted position for plucking the hair, and such that the pinching plates are caused to be opened when reaching the most retracted position for releasing the hair.

2. A depilating device as set forth in claim 1, wherein said top opening (23) has a periphery lying in a generally flat plane, said arcuate path constituting an inclined path extending in an inclined relation to said general plane of the periphery of said opening (23) between said extended position and said retracted position.

3. A depilating device as set forth in claim 1, wherein said housing (110) accommodates a carrier (141)

carrying said plurality of pinching plates (43, 44; 143, 144), said carrier (141) being coupled to said drive means (165, 166, 149) for reciprocation along said arcuate path about said longitudinal axis of said carrier.

4. A depilating device as set forth in any of claim 1 to 3, wherein each pair of adjacent pinching plates comprises a fixed pinching plate and a movable pinching plate.
5. A depilating device as set forth in claim 4, wherein said fixed pinching plates are made of an elastic material.

Patentansprüche

1. Enthaarungsvorrichtung zum Entfernen von Haaren von der Haut eines Benutzers, die umfaßt:
- ein Gehäuse (10; 110) mit einer oberen Öffnung (23; 123);
 - eine Trägervorrichtung (41), die in dem Gehäuse befestigt ist und die eine Längsachse aufweist und auf der eine Reihe von sowohl festen als auch beweglichen Klemmplatten (43, 44; 143, 144) montiert sind, die längs einer axialen Richtung der Trägervorrichtung so angeordnet sind, daß sie schmale Zwischenräume zwischen den jeweiligen Spitzen angrenzender Platten zum Ergreifen von Haaren zwischen diesen definieren;
 - Verschiebmittel (50A, 50B; 150A, 150B), die für einen Versatz der beweglichen Klemmplatten entlang der Längsachse so an die beweglichen Klemmplatten gekoppelt sind, daß sie wiederholt die Haare zwischen den Spitzen der angrenzenden Platten einklemmen und nachfolgend die Haare freigeben;

dadurch gekennzeichnet, daß

- die Vorrichtung ein Antriebsmittel (65, 66, 49; 165, 166, 149) umfaßt, das mit einer Vielzahl von Klemmplatten (43, 44; 143, 144) für ein Hin- und Herbewegen der Klemmplatten längs eines gekrümmten Weges um die Längsachse zwischen einer ausgefahrenen Position, bei der die Spitzen der Platten die Öffnung (23; 123) in einer in Eingriff bringbaren Beziehung zu den Haaren auf der Haut erreichen, und einer zurückgefahrenen Position, bei der die Spitzen der Platten von der Öffnung weg in das Gehäuse zurückgefahren sind, gekoppelt ist;
- wobei das Antriebsmittel während des Hin- und Herfahrens so mit dem Verschiebmittel zusammenwirkt, daß sich die Klemmelemente für

ein Klemmen des Haares während der Bewegung der Spitzen entlang des gekrümmten Weges von der am meisten zurückgefahrenen Position bis zu der am meisten ausgefahrenen Position schließen und anfänglich während einer Bewegung in der Rückwärtsrichtung von der am meisten ausgefahrenen Position zu der am meisten zurückgefahrenen Position für ein Auszupfen des Haars geschlossen gehalten werden, und so daß die Klemmplatten zum Freigeben des Haares geöffnet werden, wenn sie die am meisten zurückgefahrne Position erreichen.

2. Enthaarungsvorrichtung nach Anspruch 1, wobei die obere Öffnung (23) einen Umfangsbereich aufweist, der in einer im wesentlichen flachen Ebene liegt, wobei der gekrümmte Weg einen schrägen Pfad bildet, der sich in einer schrägen Beziehung zu der allgemeinen Ebene des Umgebungsbereichs der Öffnung (23) zwischen der ausgefahrenen Position und der zurückgefahrenen Position erstreckt.
3. Enthaarungsvorrichtung nach Anspruch 1, wobei das Gehäuse (110) eine Trägervorrichtung (141) aufnimmt, die die Vielzahl der Klemmplatten (43, 44; 143, 144) trägt, wobei die Trägervorrichtung (141) für eine Hin- und Herbewegung entlang des gekrümmten Weges um die Längsachse des Trägers mit dem Antriebsmittel (165, 166, 149) gekoppelt ist.
4. Enthaarungsvorrichtung nach einem der Ansprüche 1 bis 3, wobei jedes Paar aneinander angrenzenden Klemmplatten eine feste Klemmplatte und eine bewegliche Klemmplatte umfaßt.
5. Enthaarungsvorrichtung nach Anspruch 4, wobei die festen Klemmplatten aus einem elastischen Material bestehen.

Revendications

1. Dispositif à épiler pour enlever les poils de la peau d'un utilisateur comprenant :

un carter (10 ; 110) avec une ouverture supérieure (23 ; 123);

un support (41) monté sur ledit carter et ayant un axe longitudinal et supportant une série de plaques de pincement fixes et mobiles (43, 44 ; 143, 144) placées dans un sens axial dudit support pour définir de petits jeux entre les bouts respectifs des plaques adjacentes afin de coincer les poils entre eux ;

un moyen de navette (50A, 50B ; 150A, 150B) couplé auxdites plaques de pincement mobiles pour déplacer lesdites plaques de pincement mobiles le long dudit axe longitudinal pour coincer de manière répétitive les poils entre les bouts des plaques adjacentes, et ensuite libérer les poils ;

lequel lesdites plaques de pincement fixes sont en matériau élastique.

5

caractérisé en ce que

ledit dispositif comprend un moyen d'entraînement (65, 66, 49 ; 165, 166, 149) couplé à ladite pluralité de plaques de pincement (43, 44 ; 143, 144) pour animer d'un mouvement alternatif lesdites plaques de pincement le long d'un trajet arciforme autour dudit axe longitudinal entre une position allongée dans laquelle les bouts des plaques atteignent ladite ouverture (23 ; 123) dans une relation d'engagement par rapport aux poils de la peau et une position rétractée dans laquelle les bouts des plaques s'éloignent de ladite ouverture en étant rétractés dans le carter ;

10

15

20

ledit moyen d'entraînement coopère avec ledit moyen de navette au cours du mouvement alternatif de telle sorte que lesdites plaques de pincement se ferment pour coincer le poil pendant le déplacement des bouts le long dudit trajet arciforme depuis la position la plus rétractée jusqu'à la position la plus allongée et est initialement maintenu fermé pendant le déplacement dans le sens inverse depuis la position la plus allongée jusqu'à la position la plus rétractée pour arracher le poil, et de sorte que les plaques de pincement s'ouvrent lorsqu'elles atteignent la position la plus rétractée pour libérer le poil.

25

30

2. Dispositif d'épilation selon la revendication 1, dans lequel ladite ouverture supérieure (23) a une périphérie située dans un plan généralement plat, ledit trajet arciforme constituant un trajet incliné se prolongeant dans une relation inclinée par rapport audit plan général de la périphérie de ladite ouverture (23) entre ladite position allongée et ladite position rétractée.

35

40

3. Dispositif d'épilation selon la revendication 1, dans lequel ledit carter (110) loge un support (141) portant ladite pluralité de plaques de pincement (43, 44 ; 143, 144), ledit support (141) étant couplé audit moyen d'entraînement (165, 166, 149) en vue d'un mouvement alternatif le long dudit trajet arciforme autour dudit axe longitudinal dudit support.

45

50

4. Dispositif d'épilation selon l'une quelconque des revendications 1 à 3, dans lequel chaque paire de plaques de pincement adjacentes comprend une plaque de pincement fixe et une plaque de pincement mobile.

55

5. Dispositif d'épilation selon la revendication 4, dans

Fig. 1

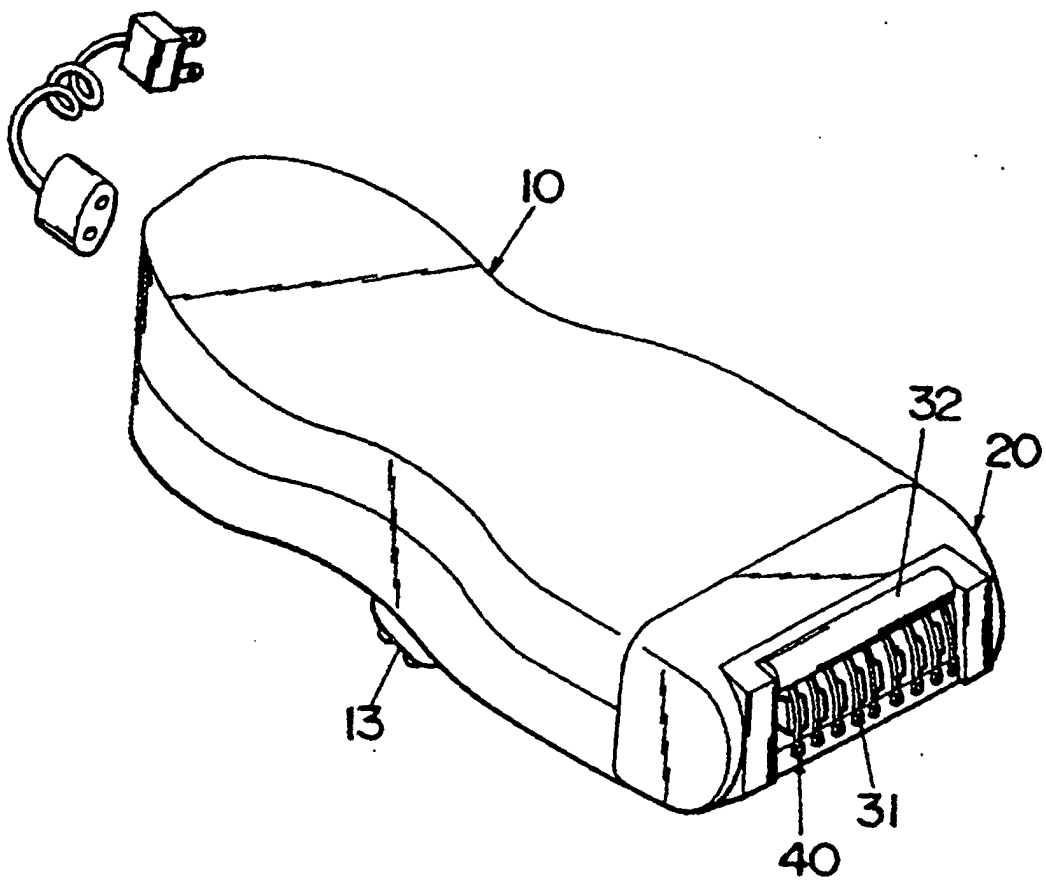
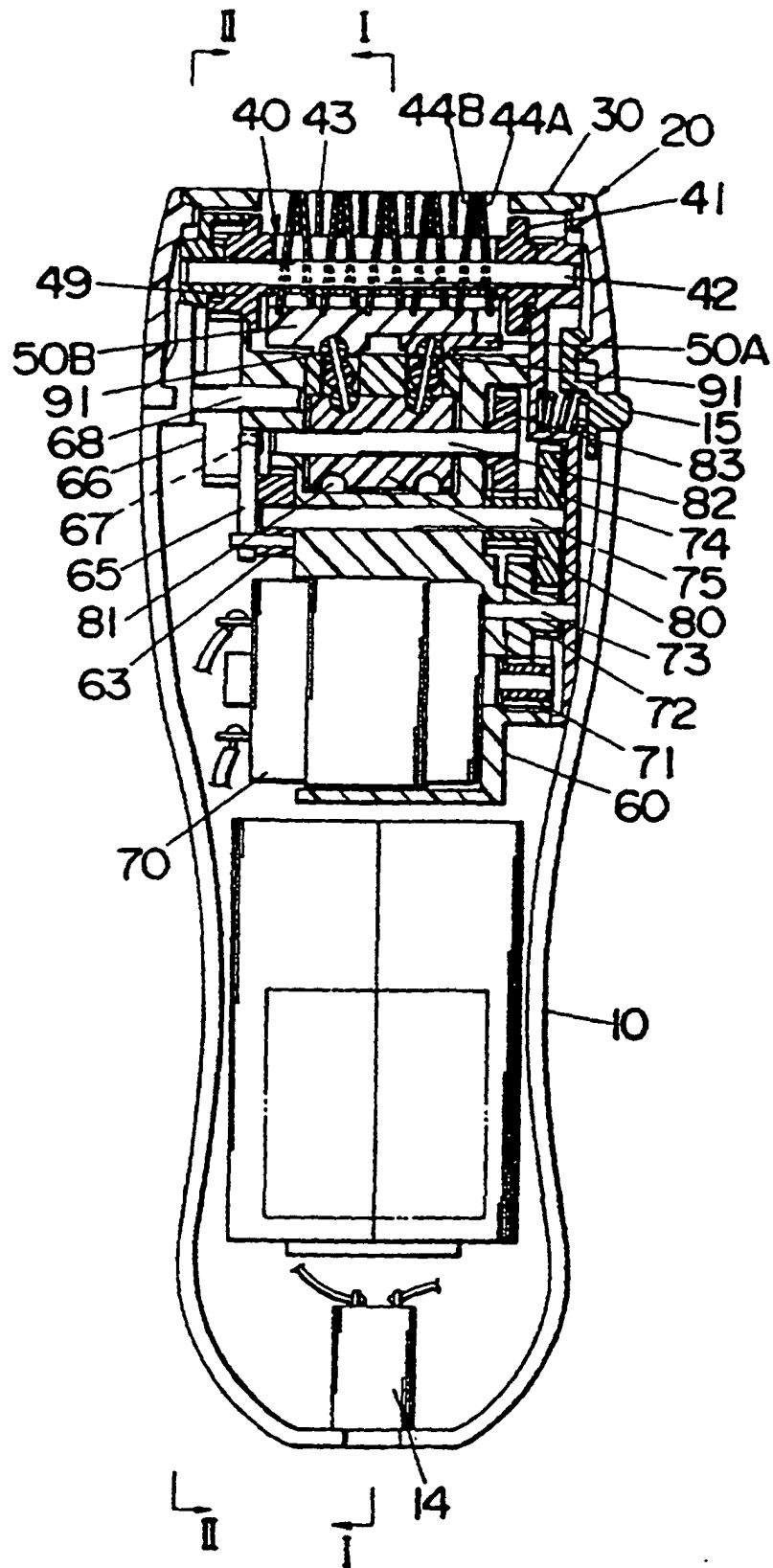
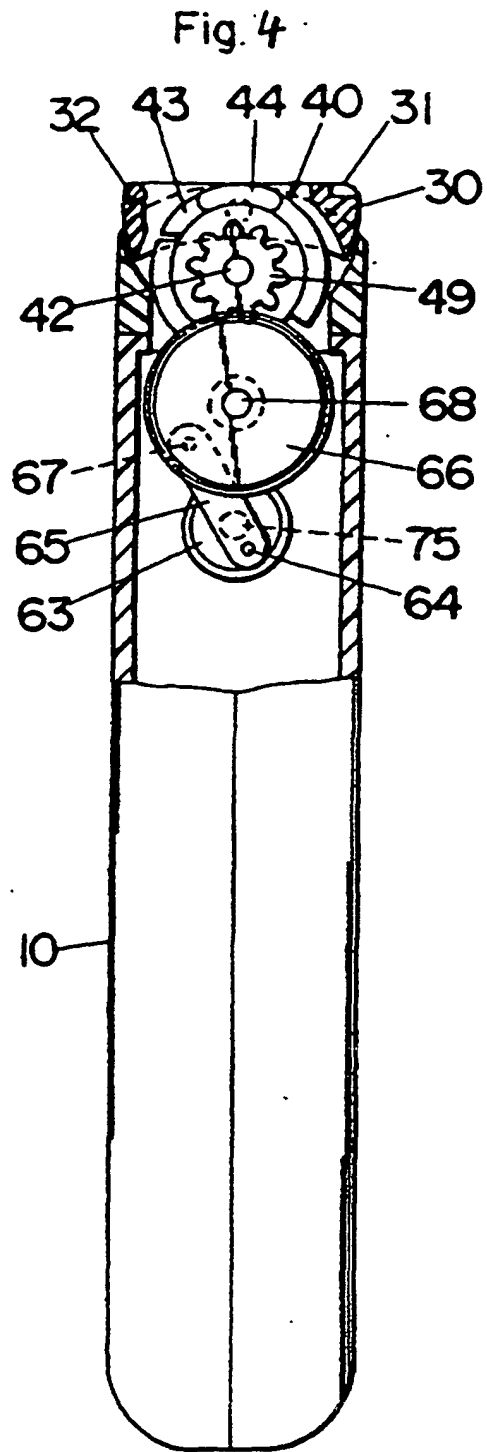
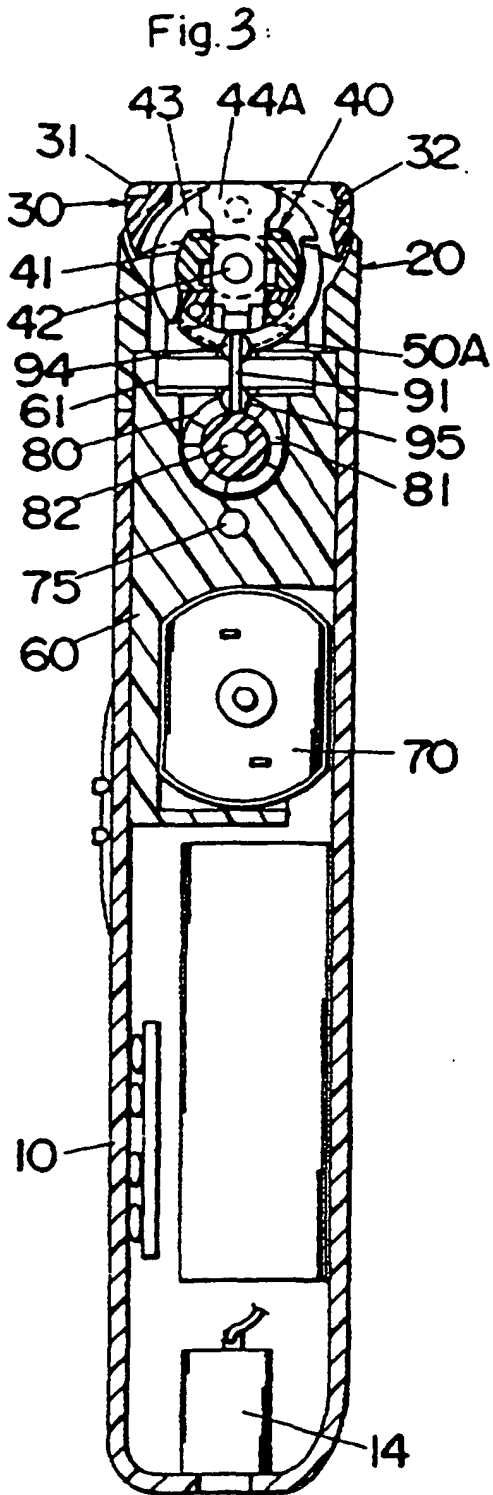
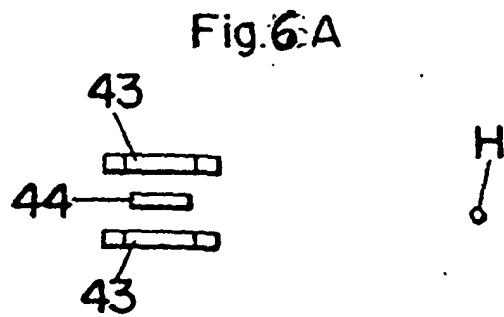
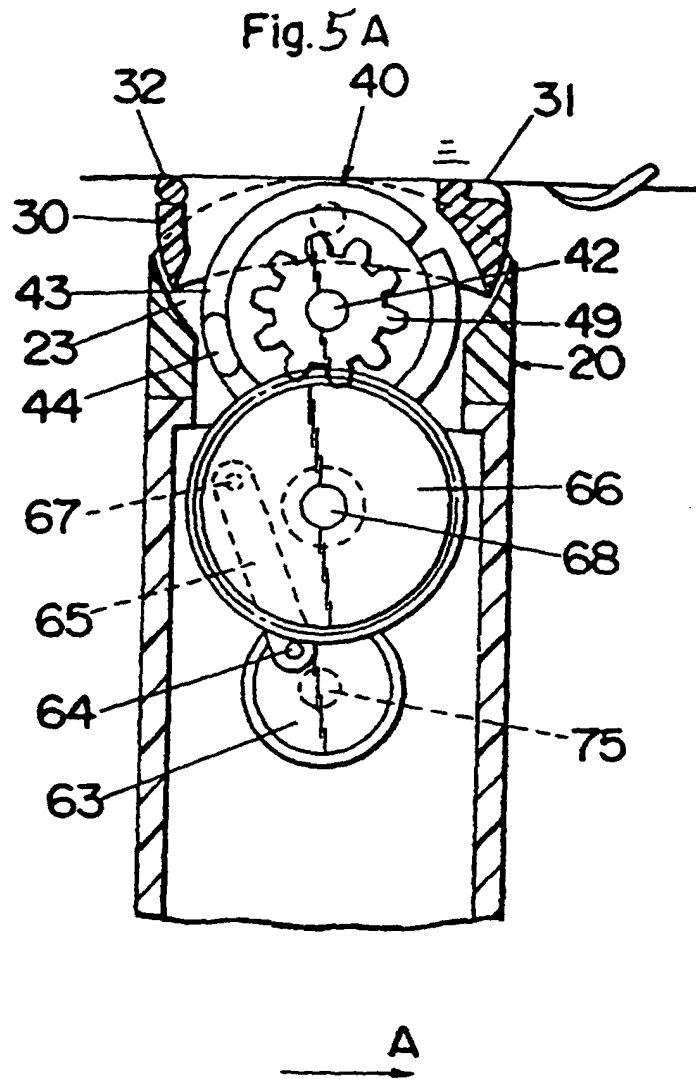
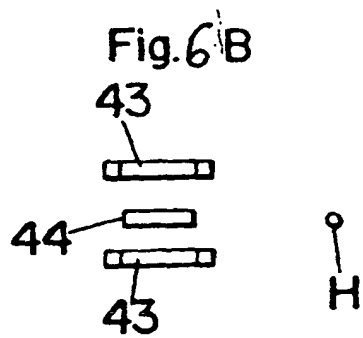
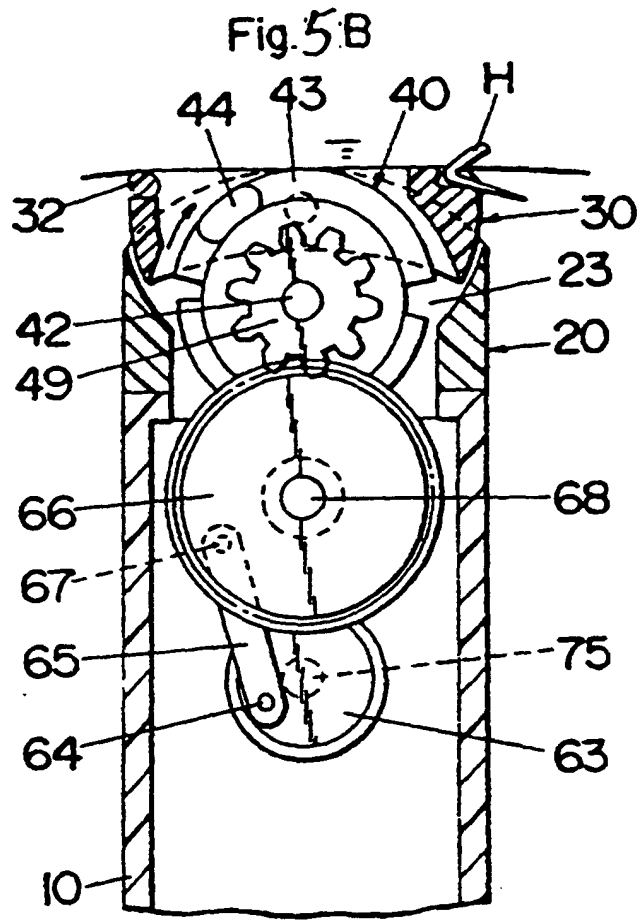

Fig.2









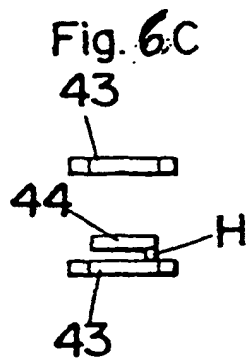
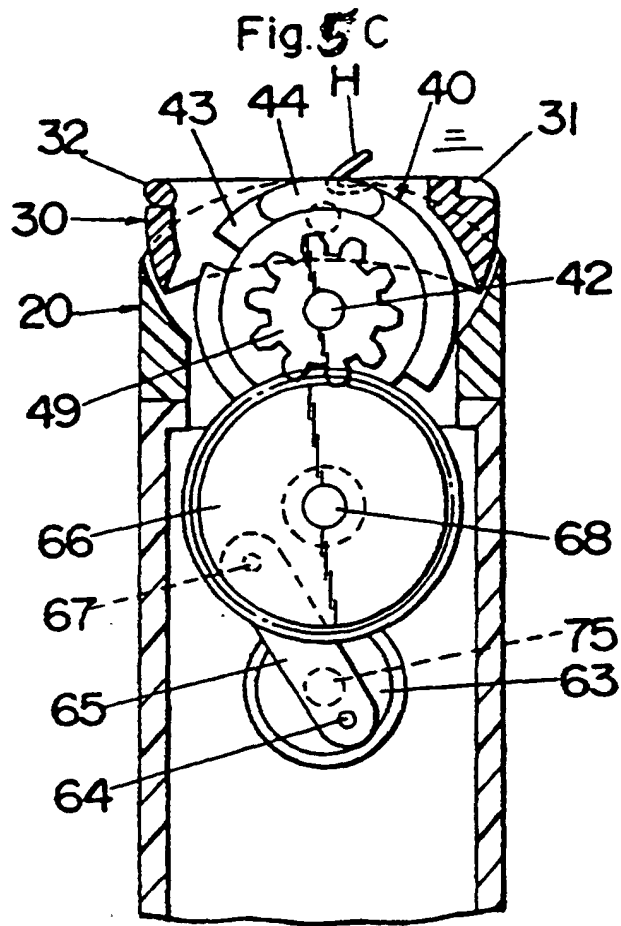

Fig. 5 D

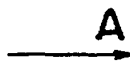
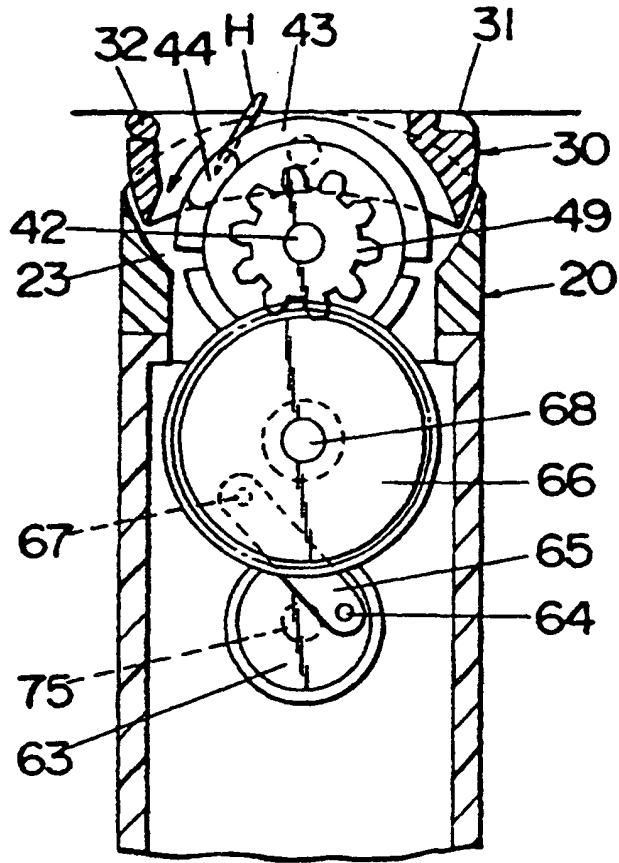

Fig. 6 D

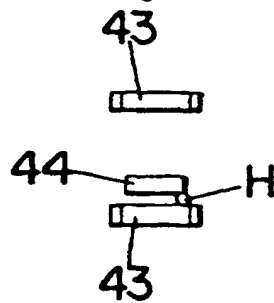
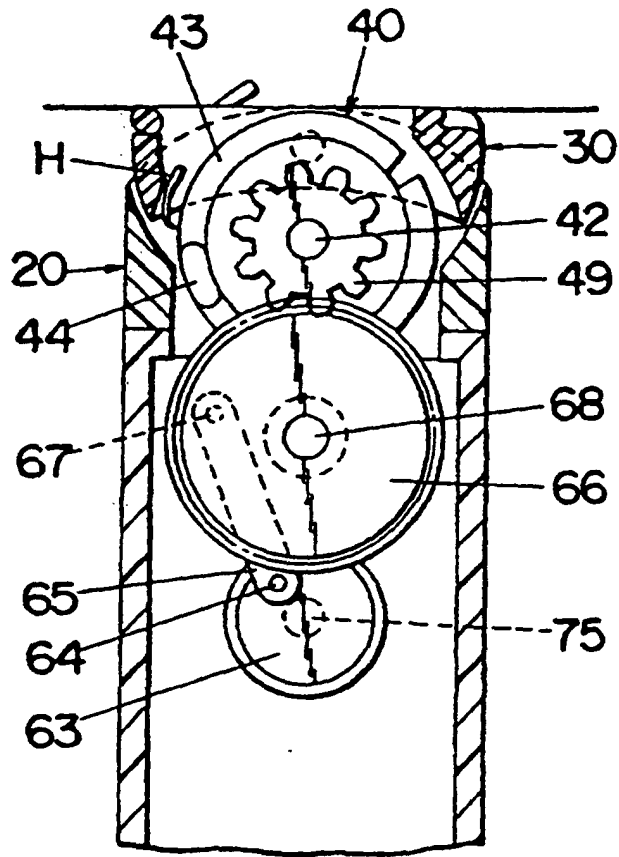
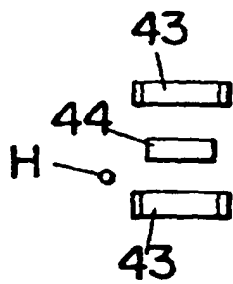

Fig. 5 E



A

Fig. 6 E



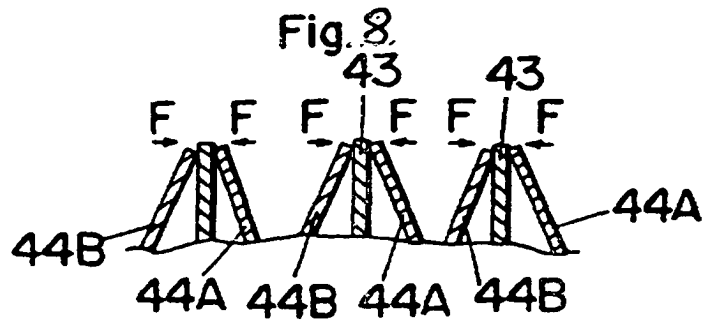
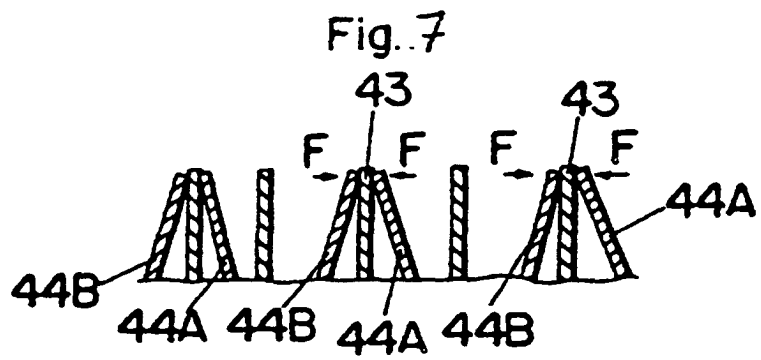
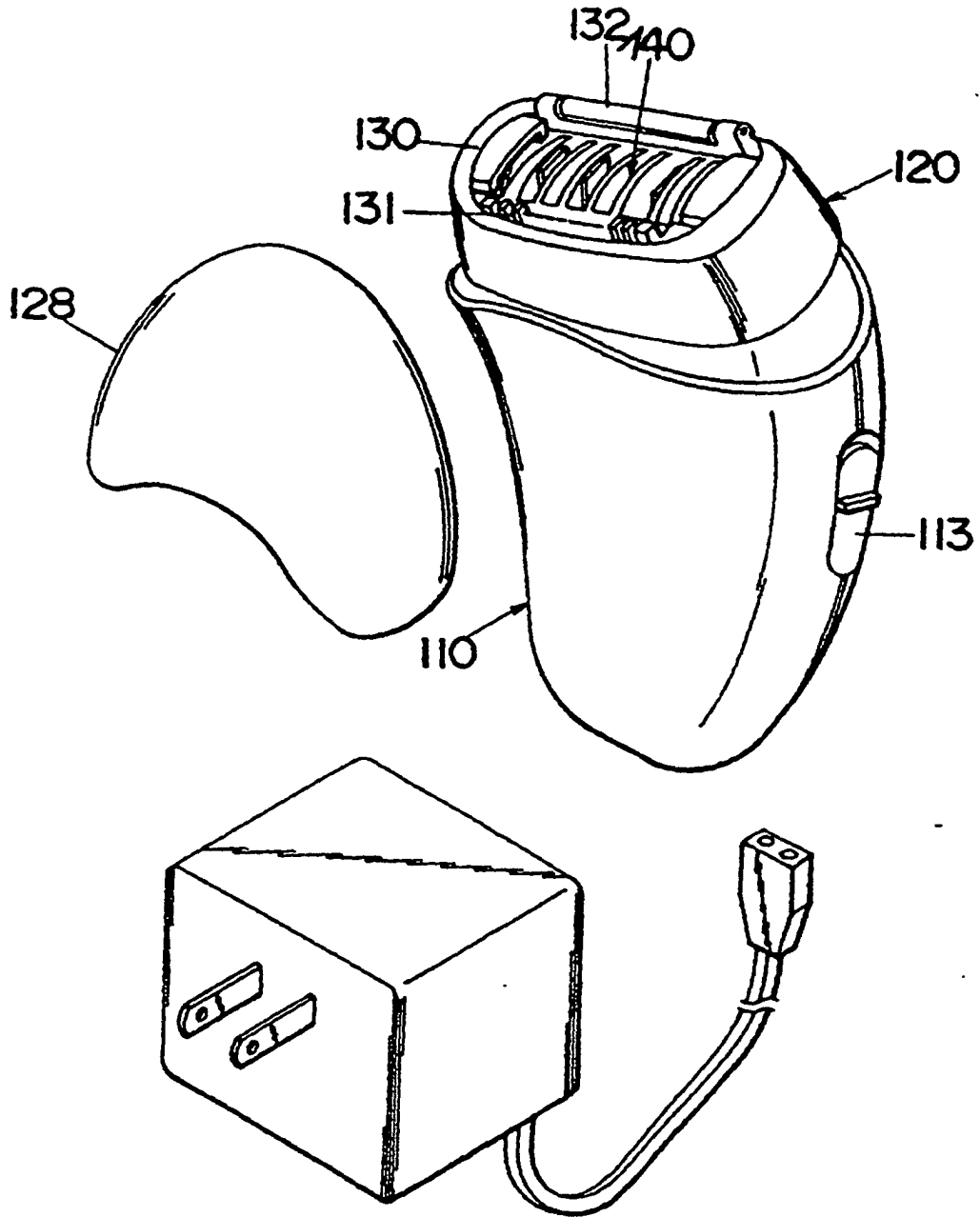
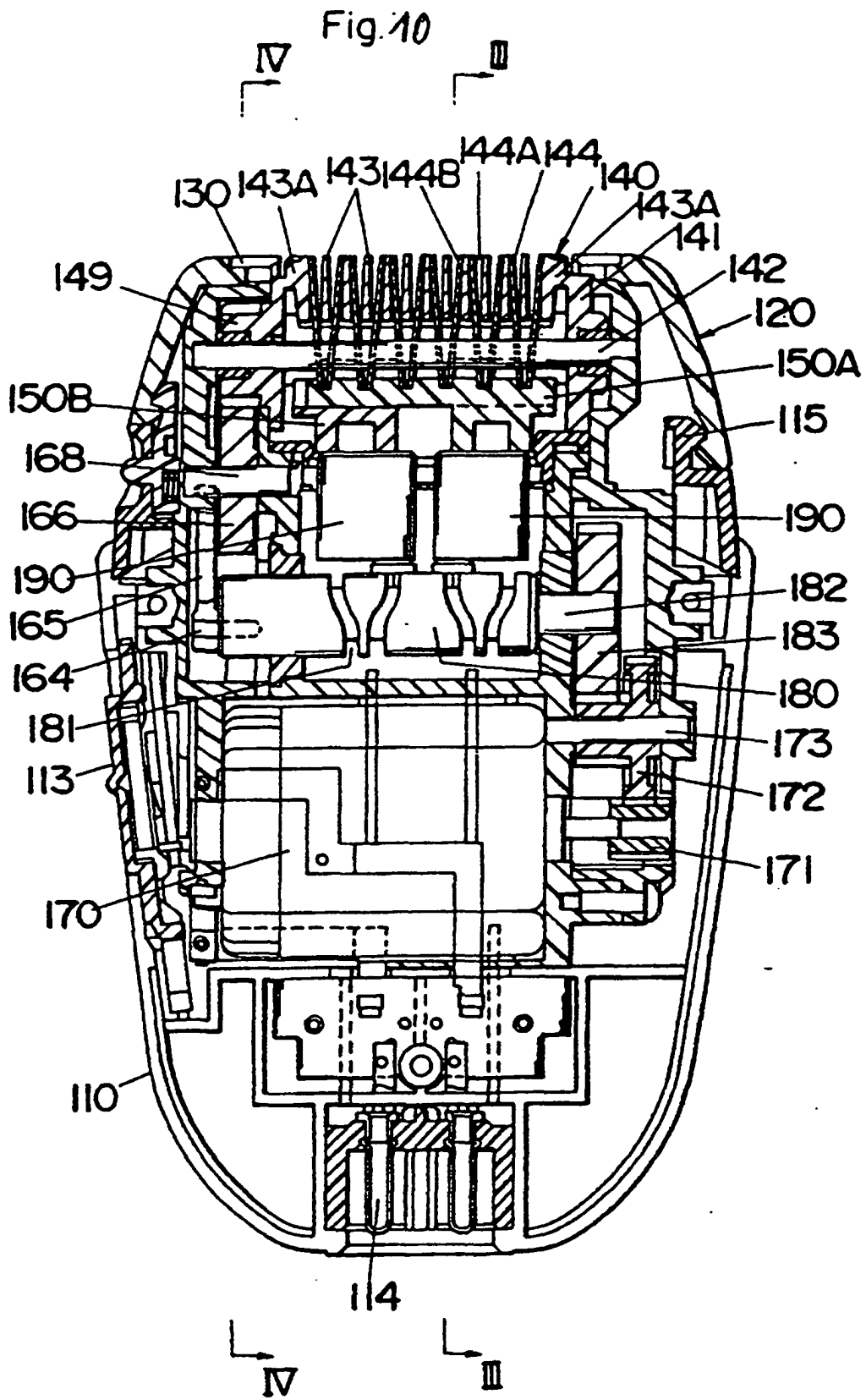

Fig. 9.





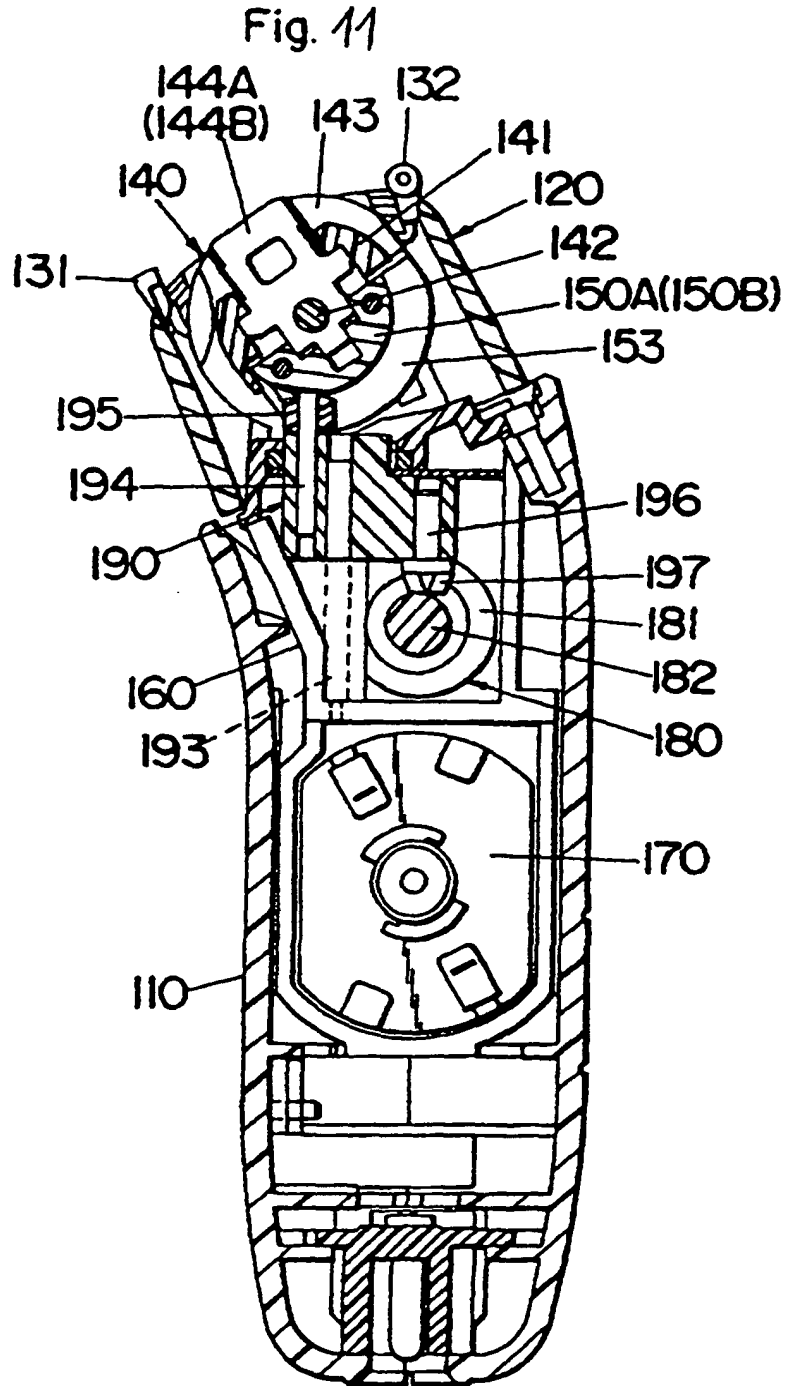

Fig. 12

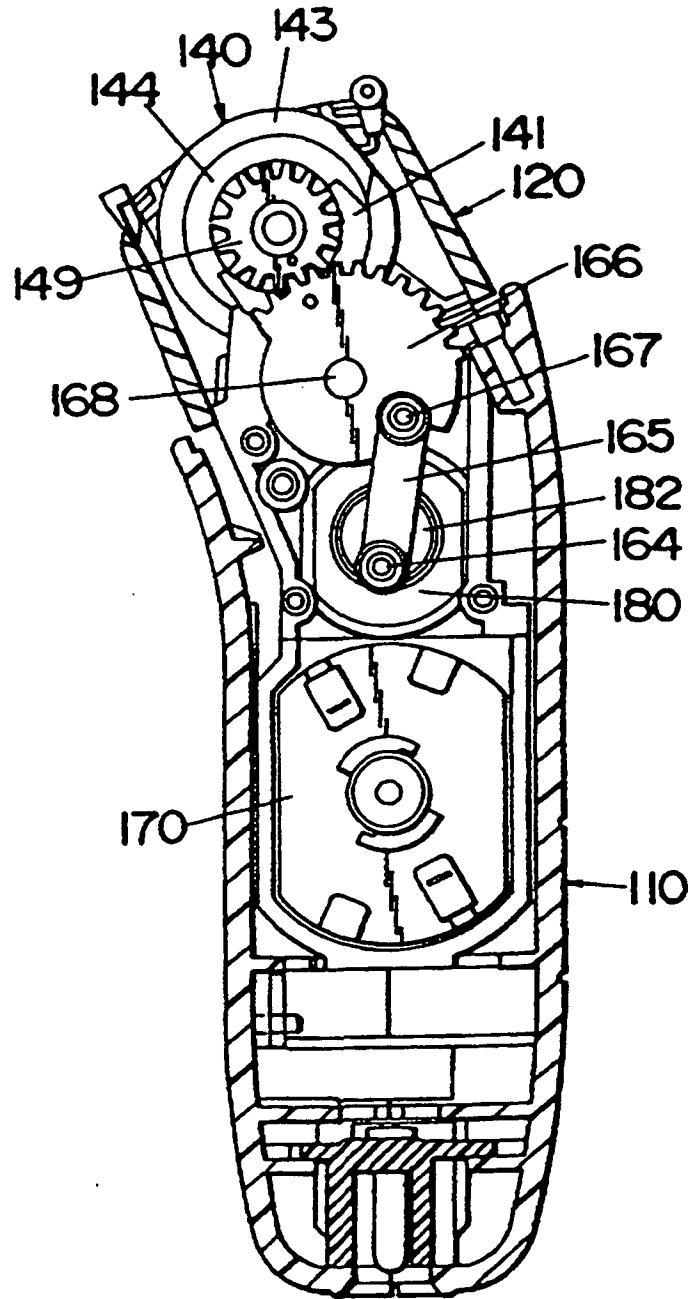
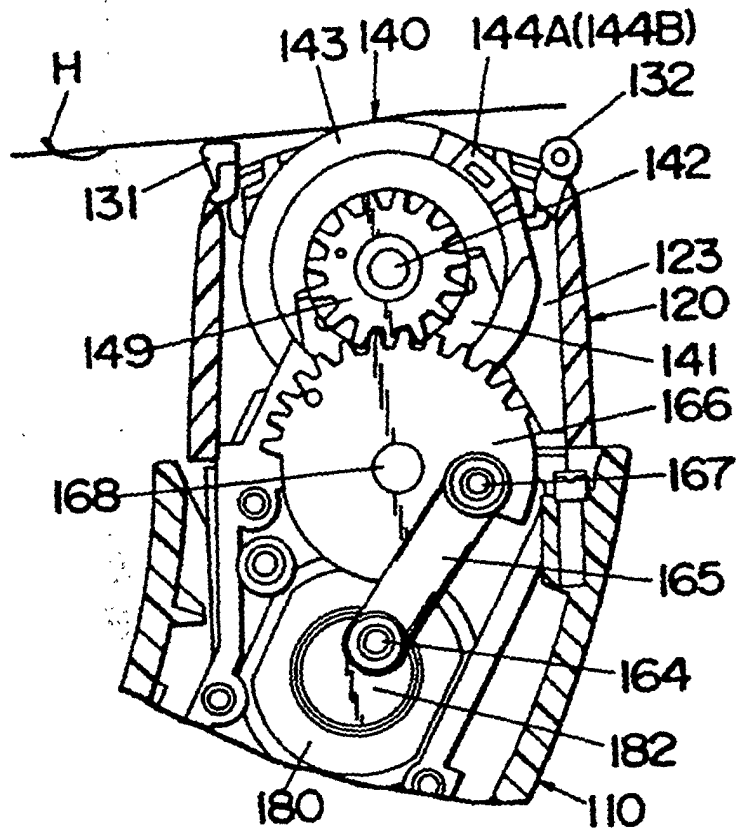

Fig. 13A



A

Fig. 14A

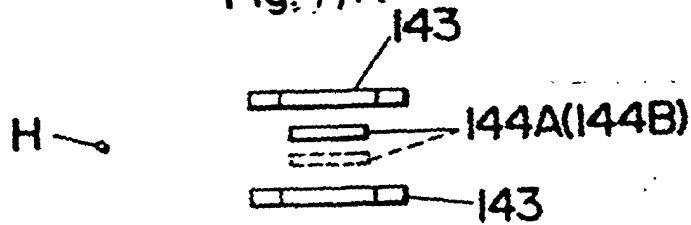

Fig. 13B

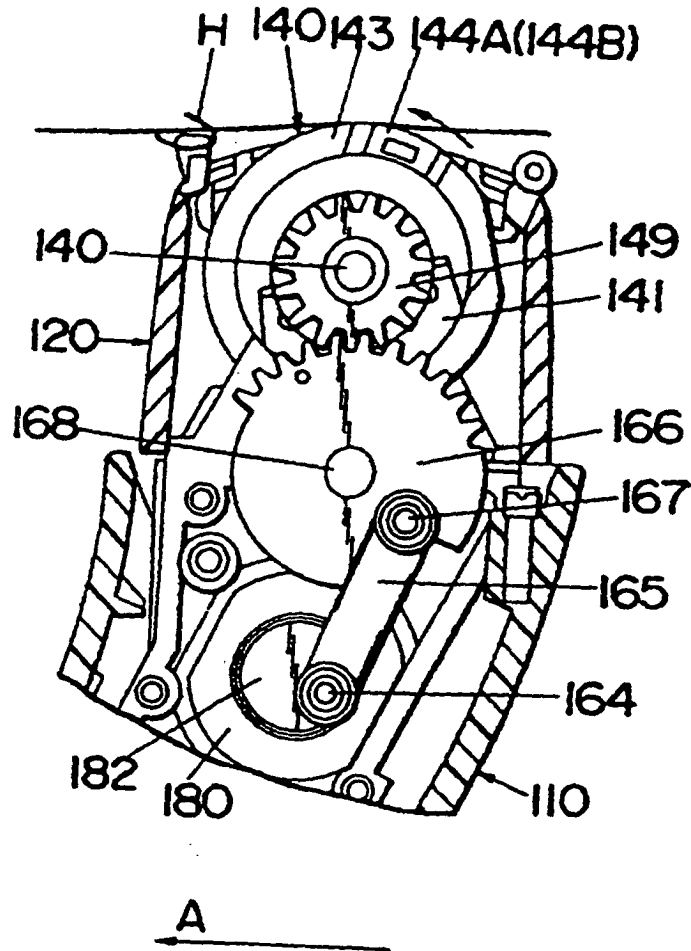
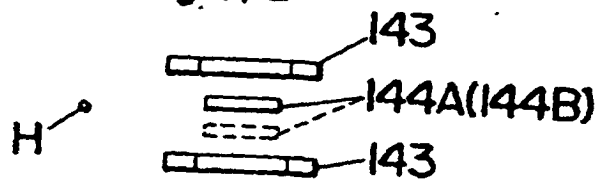

Fig. 14B



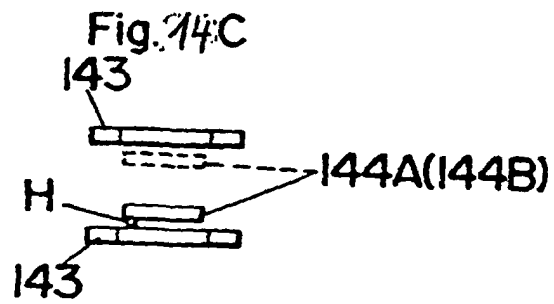
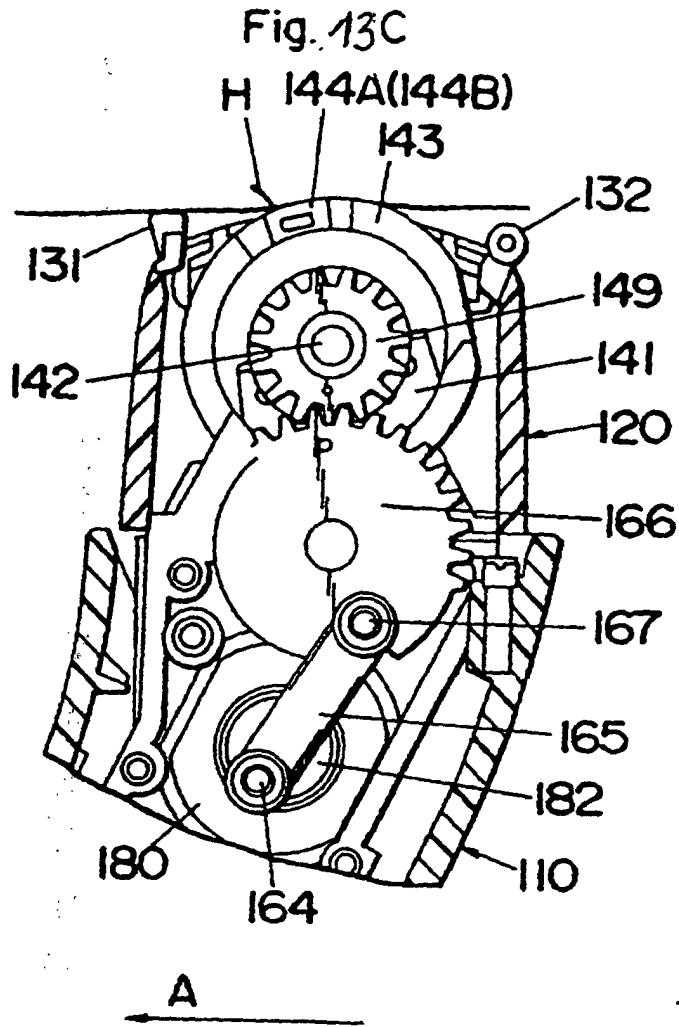

Fig. 13D

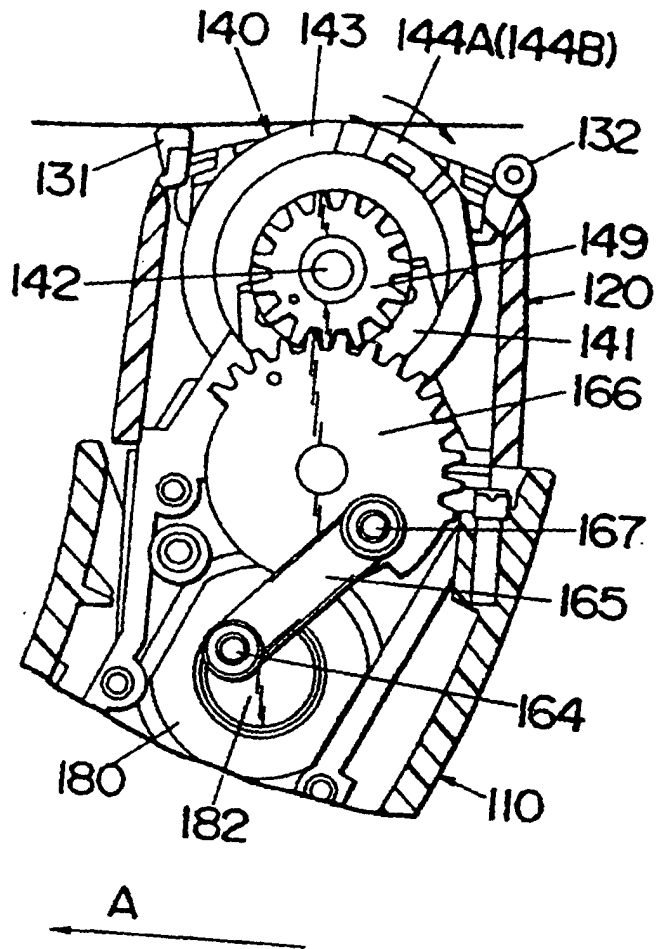

Fig. 14D

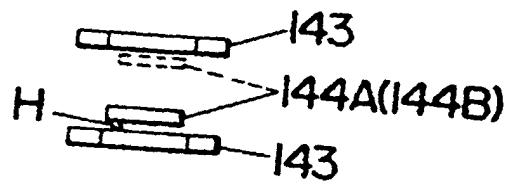

Fig. 13E

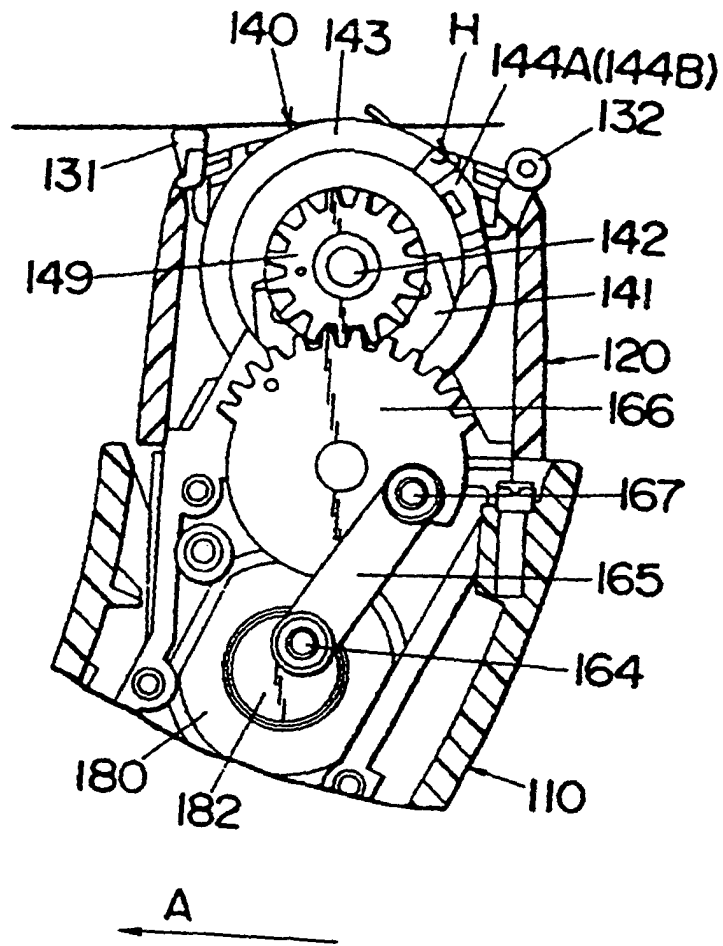

Fig. 14E

