

No. 788,150.

PATENTED APR. 25, 1905.

J. W. WINN.
BABY HOLDER.

APPLICATION FILED OCT. 17, 1904.

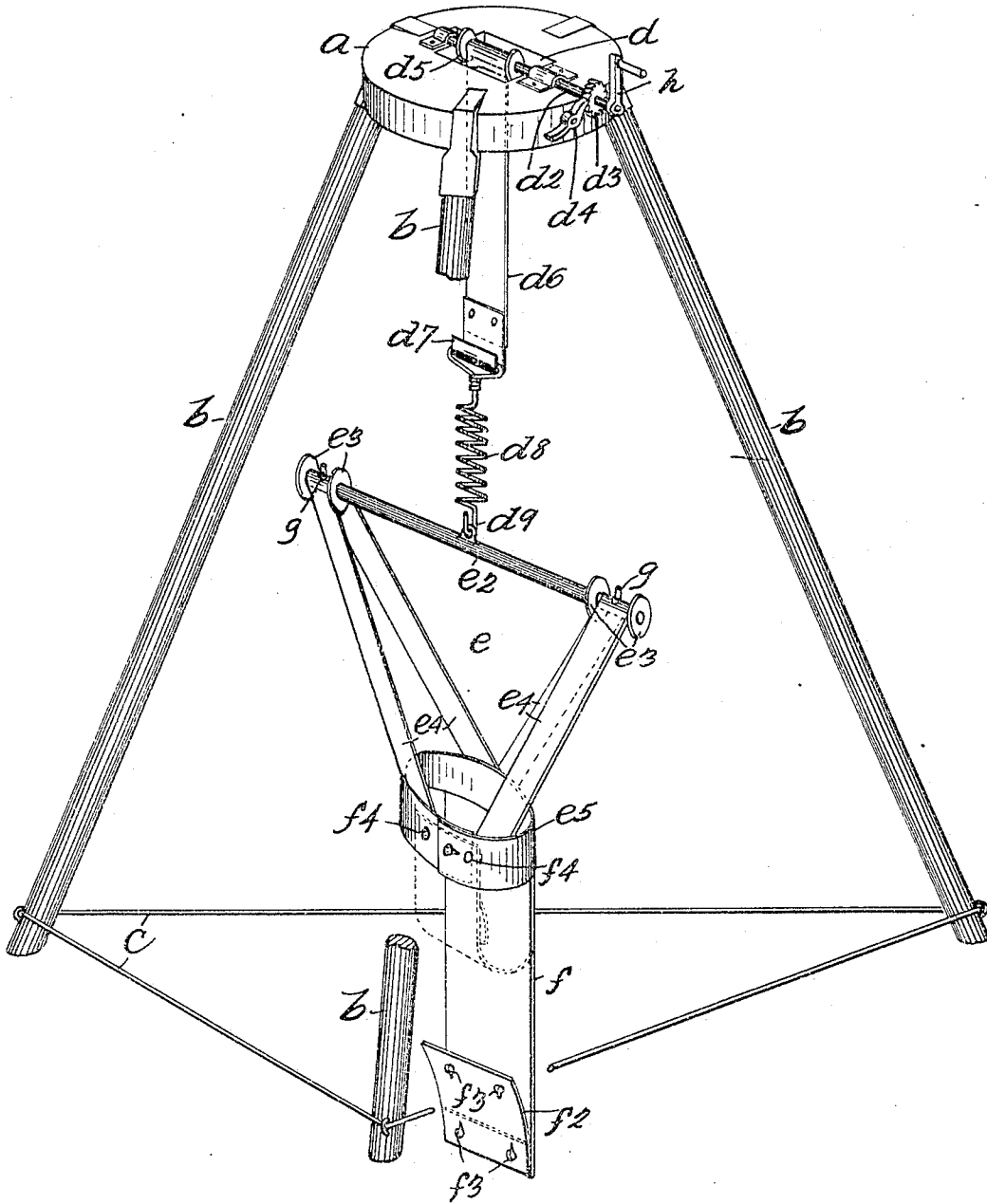

WITNESSES
J. E. Hansen
F. A. Stewart

INVENTOR
James Walter Winn
BY
Edgar Tate & Co
ATTORNEYS

UNITED STATES PATENT OFFICE.

JAMES WALTER WINN, OF NEW ORLEANS, LOUISIANA.

BABY-HOLDER.

SPECIFICATION forming part of Letters Patent No. 788,150, dated April 25, 1905.

Application filed October 17, 1904. Serial No. 228,729.

To all whom it may concern:

Be it known that I, JAMES WALTER WINN, a citizen of the United States, residing at New Orleans, in the parish of Orleans and State of Louisiana, have invented certain new and useful Improvements in Baby-Holders, of which the following is a specification, such as will enable those skilled in the art to which it appertains to make and use the same.

The object of this invention is to provide an improved device for holding or supporting babies which will not only amuse and please the child or baby, but will also aid in teaching the said child or baby to walk, a further object being to provide a device of the class specified which is particularly designed for use in families where the mother or other party having charge of the child or baby has work to do or other matters to attend to; and with these and other objects in view the invention consists in a device of the class specified constructed as hereinafter described and claimed.

The invention is fully disclosed in the following specification, of which the accompanying drawing forms a part, in which the separate parts of my improvement are designated by suitable reference characters, said drawing being a perspective view of my improved baby support or holder, with part of the construction broken away.

In the practice of my invention I provide a baby support or holder, comprising a top head plate or member *a*, which is provided with three or more legs *b* and which in form resembles an ordinary tripod, and the legs *b* are preferably connected at their lower end by a rope, chain, or cord *c*, and said legs are pivotally connected with the top member *a*.

The top member, plate, or head *a* is provided with a central oblong opening *d*, over which and longitudinally thereof is mounted a shaft *d*², provided at one end with a ratchet-wheel *d*³, and a pawl *d*⁴ engages said ratchet-wheel and is designed to prevent the backward rotation of said shaft in the operation of the device, as hereinafter described. The shaft *d*² is also provided at one end with a crank *h*, and centrally thereof and in or over the opening *d* is a spool or drum *d*⁵, on which

is wound a strap *d*⁶, which depends through the top member or head *a* and which is in the form of construction shown provided at its lower end with a hook *d*⁷, from which is suspended a spiral spring *d*⁸, the lower end of which is provided with a hook *d*⁹, from which is suspended the harness *e*, which forms the support proper of the baby or child.

The harness *e* consists of a top rod or bar *e*², each end of which in the form of construction shown is provided with two collars *e*³, and suspended from each end of said rod or bar are straps *e*⁴, the lower ends of which are connected with a flexible band *e*⁵, which is adapted to be passed around the waist of the baby or child and the separate ends of which may be connected, as shown at *e*⁵, by means of buttons, buckles, or any other form of devices, said connection being preferably so made that the length of the band *e*⁵ may be adjusted as desired.

From the back of the band *e*⁵ is suspended a strap *f*, which is preferably of considerable width and the free end of which in the form of construction shown is provided with a loose folded portion *f*², and said folded portion *f*² or the free end of the strap *f* is provided with buttonholes *f*³, which are adapted to engage or be engaged by buttons *f*⁴ on the band *e*⁵, and in practice the child is placed in the harness by buckling the band *e*⁵ around the waist of the child and passing the strap *f* beneath the body of the child and up in front and securing the end thereof to said band. This leaves the child's legs free, as will be understood, and by means of the shaft *d*² the distance of the harness from the floor may be regulated, as will be readily understood, and this distance may be so regulated that the child's feet may just come to the floor, and the child is thus held in an upright position and in such a position that its weight may be borne on its feet, and it may in this manner learn to walk or take steps without danger of falling. The child may also jump itself up and down, the spring *d*⁸ serving, in connection with the feet, to accomplish this result, while also holding the child in proper position at all times, and when the harness is properly applied the child will be able to grasp the front straps *e*⁴ with its

hands, and thus also be enabled to hold the upper part of its body in proper position.

In the form of construction shown the straps e^4 at each end of the rod or bar e^2 are formed integrally and simply pass over the ends of the said rod or bar, and pins or other devices g are passed through said straps into said rod or bar to keep said straps from slipping crosswise of said rod or bar, while the collars e^3 prevent said straps from slipping longitudinally of said rod or bar.

The parts e^4 , e^3 , and f of the harness may be made of any suitable flexible material, but are preferably made of canvas or similar fabric, and this device may be placed on the floor of a room, on a porch, or on the ground, or wherever it is convenient to place it, and a mother or other caretaker of the child may place the same in the harness e and go about her work or occupation, and the child will be amused or amuse itself for an indefinite time.

The main supports or the parts a or b are preferably made of wood, but may be made of any preferred material, and changes in and modifications of the details of the construction herein described may be made without departing from the spirit of my invention or sacrificing its advantages. It will also be apparent that my improved baby-holder or the parts thereof may be compactly folded together when not in use and for purposes of shipment, and by reason of the tripod shape

or form of the main support or framework the said device may be quickly and easily set up for use whenever necessary.

Having fully described my invention, what I claim as new, and desire to secure by Letters Patent, is—

1. In a device of the class described, a frame composed of a top member and legs pivoted thereto, a shaft mounted in said top member, a strap suspended from said shaft, means for turning said shaft in one direction, means for preventing the rotation of the shaft in the opposite direction, a spring suspended from the strap and a baby harness or holder suspended from said spring, substantially as shown and described.

2. In a device of the class described, a support, a shaft mounted therein, a strap suspended from said shaft, means for turning said shaft in one direction, means for preventing the turning of said shaft in the opposite direction, and a baby-suspending device connected with said strap, substantially as shown and described.

In testimony that I claim the foregoing as my invention I have signed my name, in presence of the subscribing witnesses, this 4th day of October, 1904.

JAMES WALTER WINN.

Witnesses:

EDWARD B. CHARBONNET,
J. ARTHUR CHARBONNET.