

[54] **ALARMED LATCH ASSEMBLY FOR A SLIDING DOOR**

Primary Examiner—Brian N. Vinson
Attorney, Agent, or Firm—Terry M. Gernstein

[76] Inventor: **Joseph T. Sciarrino**, 2271 Woodlawn Cir., Melbourne, Fla. 32935

[57] **CLAIM**

The ornamental design for an alarmed latch assembly for a sliding door, as shown and described.

[**] Term: **14 Years**

DESCRIPTION

[21] Appl. No.: **305,209**

FIG. 1 is a top, front, and right side perspective view of an alarmed latch assembly for a sliding door showing my new design, the cable assembly being shown broken-away for convenience of illustration;

[22] Filed: **Feb. 2, 1989**

[52] U.S. Cl. **D8/339**

FIG. 2 is a bottom plan view thereof, shown in a latched position;

[58] Field of Search D10/104, 106;
D8/330-332, 339, 341-343; 292/57, 95-97,
130, 137, 183, 101, 285, 1

FIG. 3 is a rear elevational view thereof, shown in a latched position; and

[56] **References Cited**

U.S. PATENT DOCUMENTS

2,243,872	6/1941	Le Beau	292/285
2,790,664	4/1957	Bramley et al.	292/285
4,305,611	12/1981	Robins	292/1 X

FIG. 4 is a reduced top, front, and right side perspective view thereof, with the broken-line showing of a portion of the sliding door assembly being for illustrative purposes only and forming no part of the claimed design.

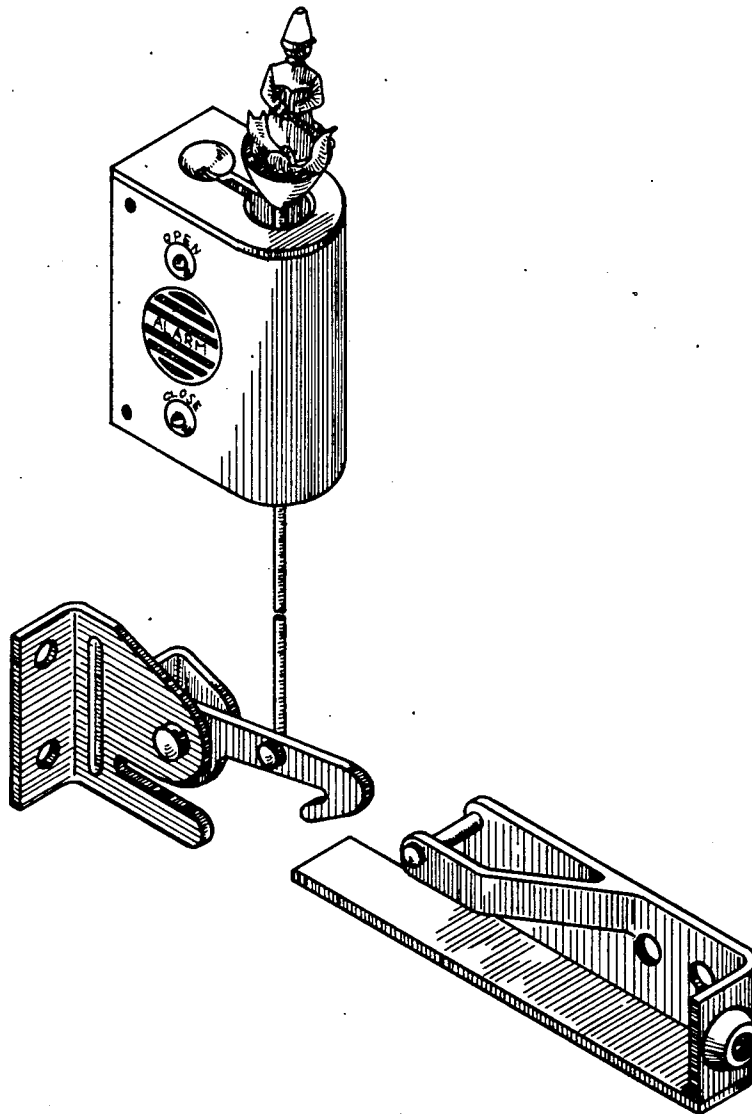

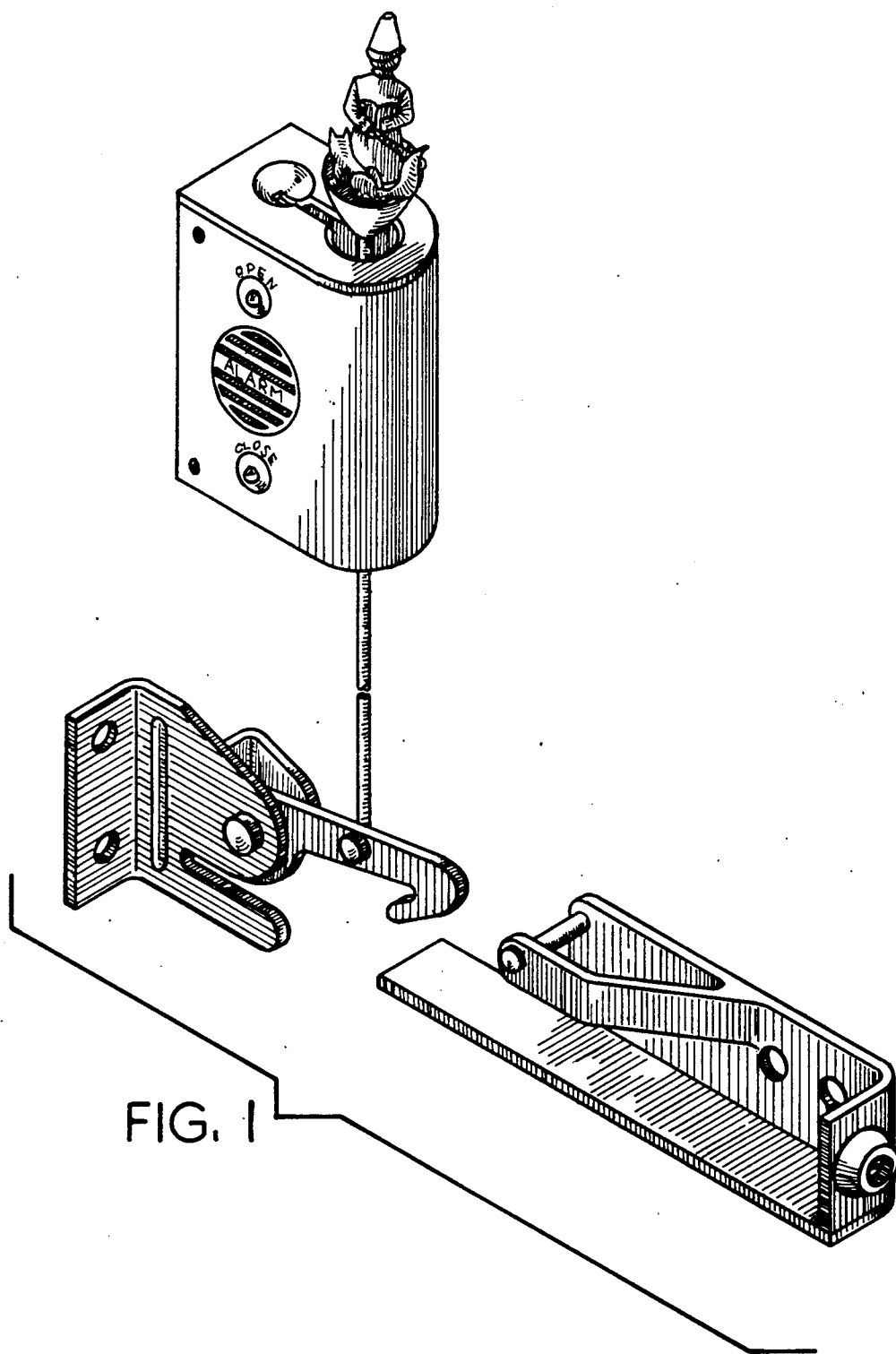

FIG. 1



FIG. 2

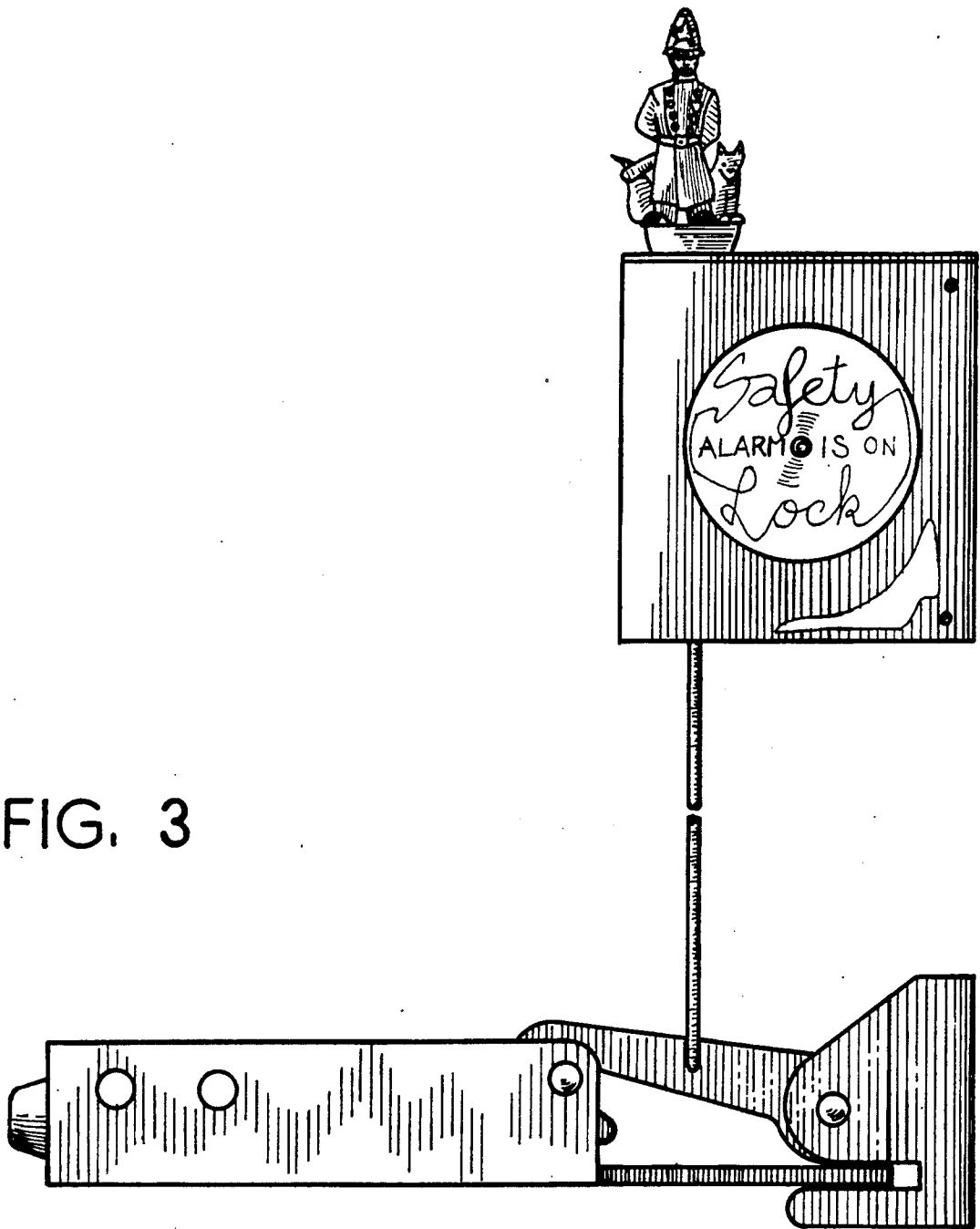

FIG. 3

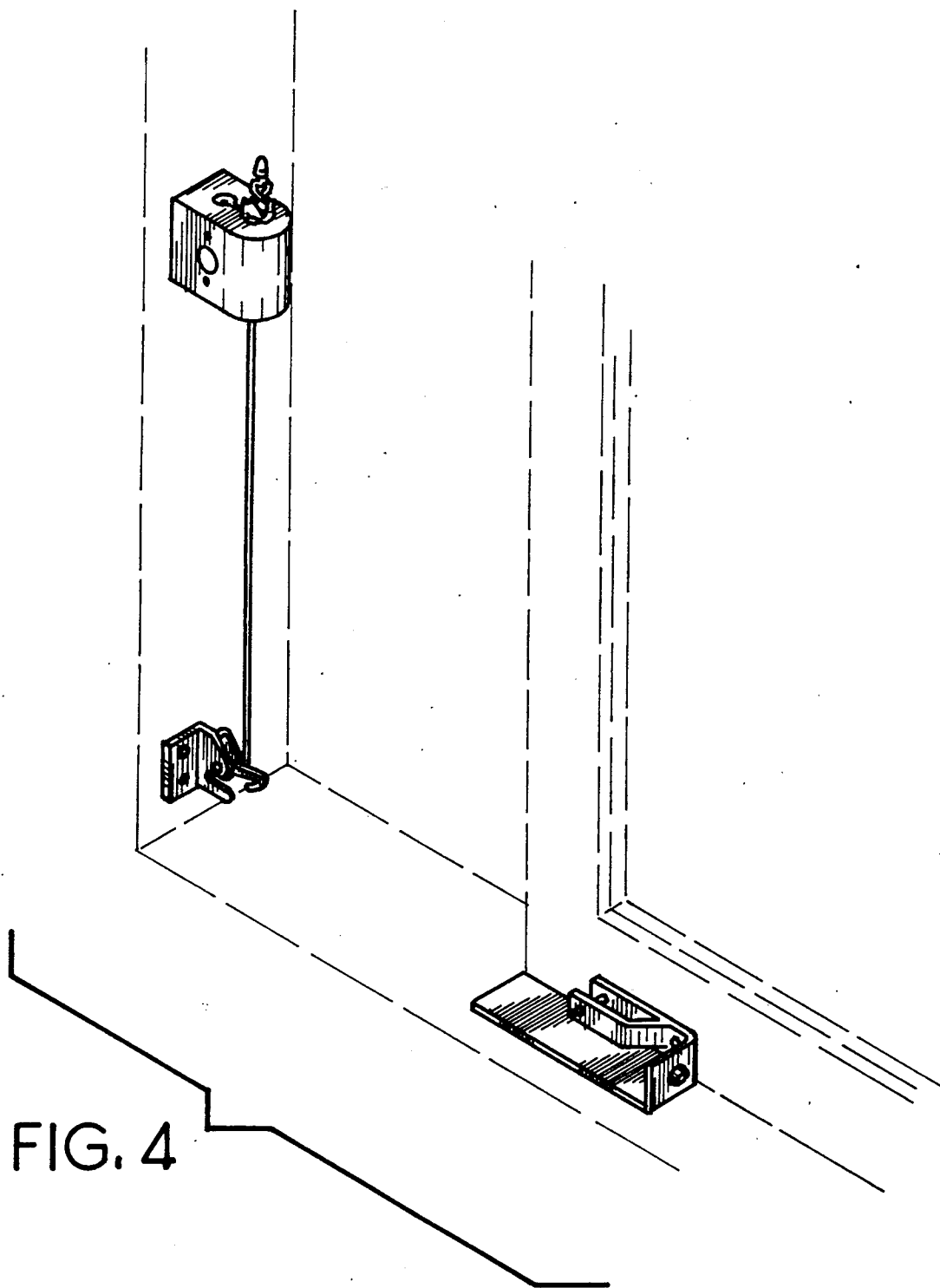

FIG. 4