

N. L. HOLMES.
ADJUSTABLE CARRIAGE POLE.

No. 562,185.

Patented June 16, 1896.

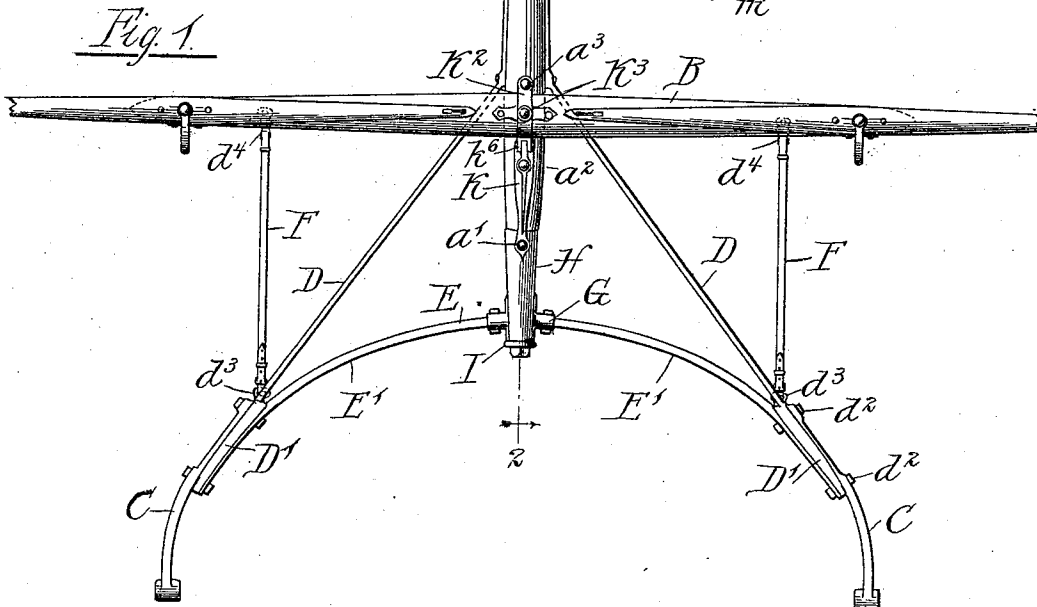
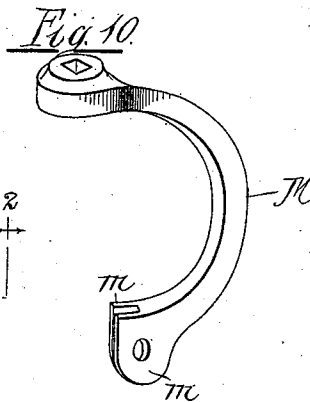
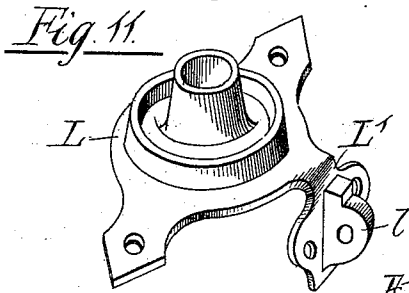
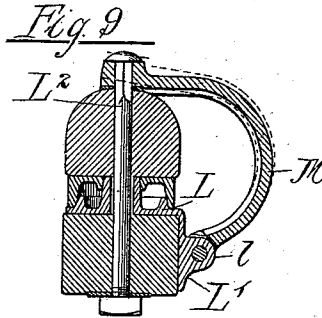
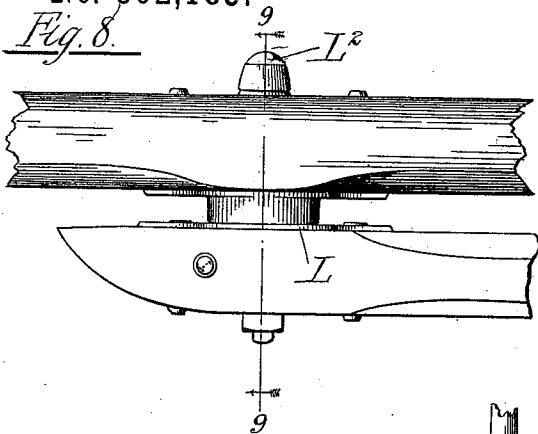

Witnesses
L. Clifton Hauflink
John W. Adams.

Inventor
Nathan L. Holmes

By *Dustin Poles Snow*
his Attorneys

N. L. HOLMES.
ADJUSTABLE CARRIAGE POLE.

No. 562,185.

Patented June 16, 1896.

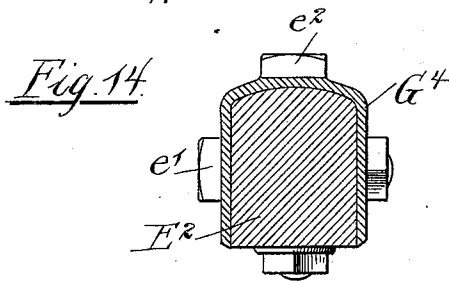
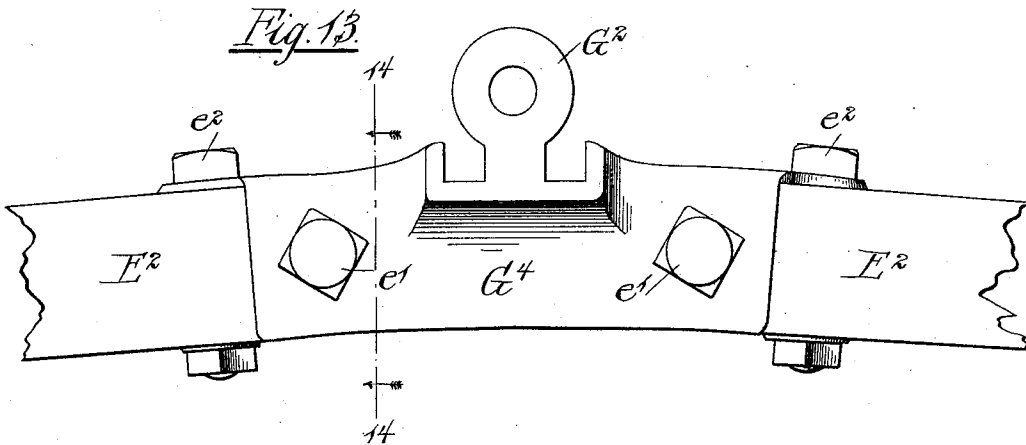
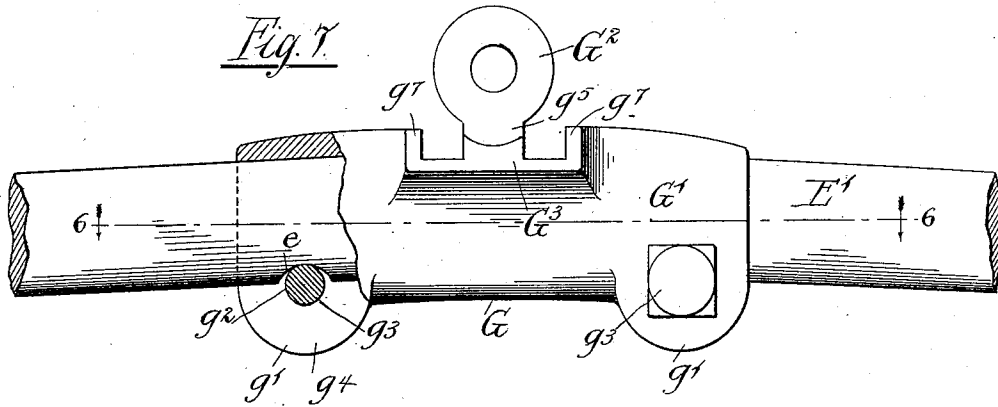

Witnesses
L. Clinton Hamlin
John W. Adams

Inventor
Nathan L. Holmes
 by *Dayton, Poole & Brown*
his Attorneys

UNITED STATES PATENT OFFICE.

NATHAN L. HOLMES, OF RACINE, WISCONSIN.

ADJUSTABLE CARRIAGE-POLE.

SPECIFICATION forming part of Letters Patent No. 562,185, dated June 16, 1896.

Application filed September 7, 1895. Serial No. 561,736. (No model.)

To all whom it may concern:

Be it known that I, NATHAN L. HOLMES, of Racine, in the county of Racine and State of Wisconsin, have invented certain new and useful Improvements in Adjustable Carriage-Poles; and I do hereby declare that the following is a full, clear, and exact description thereof, reference being had to the accompanying drawings, and to the letters of reference marked thereon, which form a part of this specification.

This invention relates to improvements in carriage-poles, and more especially to a construction by which the arms or hounds which are connected with the carriage may be adjusted, as to their distance apart, so as to fit the shackles or connecting devices on the axles of carriages having their shackles spaced at different distances apart.

Various improvements in the features of construction other than those concerned in accomplishing the adjustment described are also embraced in the invention.

The object of the invention is to provide an improved construction in devices of the character referred to; and the invention consists in the matters hereinafter described, and more particularly pointed out in the appended claims, and the same will be readily understood, reference being had to the accompanying drawings, in which—

Figure 1 is a top plan view of a carriage-pole equipped with my invention, the front end of the pole and the outer ends of the singletrees being broken away to reduce the size of the figure. Fig. 2 is a central vertical longitudinal section taken on line 2 2 of Fig. 1. Figs. 3 and 4 are details of the form of connection used in uniting the two members of each arm. Fig. 5 is a transverse section taken on line 5 5 of Fig. 3. Fig. 6 is a horizontal section through the connecting-clip, taken on line 6 6 of Fig. 7 and showing the transverse member of the arms in position therein. Fig. 7 is a rear end elevation showing the clip in position upon the transverse member, parts being broken away to expose the means by which the relative position of the parts is maintained. Fig. 8 is a front elevation of the end of the whiffletree and the central portion of a singletree connected

therewith. Fig. 9 is a transverse vertical section taken on line 9 9 of Fig. 8. Figs. 10, 11, and 12 are details of the parts shown in Figs. 8 and 9. Fig. 13 is a view similar to Fig. 7, illustrating a modification. Fig. 14 is a transverse vertical section taken on line 14 14 of Fig. 13.

Referring to said drawings, A designates the pole which carries the whiffletrees B, and C C arms or hounds by means of which the pole is connected with the front axle of the carriage. As shown in Figs. 1 to 12, inclusive, these arms consist each of two metal bars D and E', of which the bars D are attached to the sides of the pole near the point where the whiffletrees are attached thereto, while the bars E' are attached to the outer portions of the bars D, and are arranged in a direction generally transverse to and connected with the pole, so as to constitute braces or cross-bars by which the outer ends of the arms are braced laterally and held from lateral movement. The bars E' E' are curved throughout their length and arranged in alinement with each other at their inner ends, and preferably, as shown in the present instance, said bars are made integral, as a single piece (indicated as a whole by E) of spring-steel of elliptical form in cross-section. At its center said bar E has connection with adjusting devices mounted upon the end of the pole and adjustable endwise thereon so as to force the outer ends of the arms C C apart or draw them together by varying the position of the central part of the bar E with relation to the points of connection of the outer member D with the pole.

The ends of the bar E are rigidly connected with the arms D conveniently by means of cast-metal space-blocks D' D', interposed between said parts, said blocks being provided in their sides with slots or depressions $d d'$, corresponding in form to the proximate sides of the bars D and E, and adapted to receive the latter therein. Suitable bolts $d^2 d^2$, arranged to extend through said bars near each end of the space-blocks D', serve to clamp the parts immovably together. $d^3 d^3$ designate eyes or loops cast integrally with the forward ends of said space-blocks, with which are connected the rear ends of the usual stay-straps F, the

other ends of said straps being connected with similar loops d^4 d^4 , suitably secured to the lower side of the whiffletree.

The construction by which the loops d^3 d^3 are formed integrally with the space-blocks D' is a feature of importance, inasmuch as it simplifies the device, lessens the number of parts to assemble, and forms a more rigid and reliable connection than when said loops are made separate and secured to the pole by separate fastening devices.

Now, describing in detail the adjusting devices, G designates a clip, by means of which the transverse bar E is adjustably connected with the end of the pole A . Said clip comprises a transversely-arranged sleeve or embracing portion G' , provided with a bore conforming to the cross-sectional shape of the bar E , (in the present instance elliptical,) which bore or chamber is enlarged slightly throughout its central portion, as indicated at g g , to permit slight lateral movement or bending of the bar E therein. At each end the embracing portion G' is provided at its lower side with lugs g' g' , which are horizontally apertured, as at g^2 g^2 , to receive clamping-bolts g^3 g^3 . In order to hold the bar E positively from endwise movement within the clip, the centers of said apertures g^2 are arranged approximately in line with the lower margin of the bar E , and the latter is provided with circular notches e , which receive the upper sides of the bolts g^3 g^3 . The lug portions g' g' of said sleeve are divided by means of central vertical openings or slots g^4 g^4 , so as to permit the necessary yielding and clamping action of the end portions of the sleeve when the bolts G^3 are drawn up.

At its upper side the clip G is provided with a transversely-arranged cylindrical adjusting-nut G^2 , connected with the main body of the clip by means of a vertical web portion g^5 . The adjusting-nut G^2 is arranged to fit and slide within a hollow tubular socket II , mounted upon and forming an extension of the rear end of the pole. The interior of the socket II is divided transversely into two chambers h and h' , separated by a transverse partition h^2 , the rear chamber h being made accurately cylindrical to receive the nut G^2 , while the forward chamber is made flaring outwardly from the partition h^2 , to conform to and receive the end portion a of the body of the pole. The rear end of the socket is made open to permit the entrance of the nut G^2 endwise therein, while the under side of the socket is slotted longitudinally from said rear end forwardly to a point some distance beyond the partition h^2 , to receive the web portion g^5 , which unites the adjusting-nut with the body of the clip, and a rib g^6 , which forms an extension of said web g^5 , and affords additional length of bearing, said web g^6 being arranged to pass beneath the partition h^2 in its forward movement.

In order to afford additional guiding-support for the clip in its movement upon the

pole, so as to prevent any oscillatory movement of the bar E with relation to the pole, the part of the clip with which the adjusting-nut is united is extended forwardly and rearwardly of the transversely-arranged embracing part G' , in the form of a strap or flat bar G^3 , which underlies the socket II , the rear end of the portion of said part G^3 being provided with upturned lateral flanges g^7 g^7 , which engage the outer sides of the socket II , while the front end of said strap is centrally slotted longitudinally, as at g^8 , and has engagement with and slides upon the lower end of a bolt a' , inserted vertically through the body of the pole A . Said bolt a' serves also as one of three securing-bolts a' a^2 a^3 , which are extended vertically through the body of the pole and through a strap h^4 , formed integrally with the socket II , and arranged to extend forward therefrom on the under side of the pole to a point beyond or in front of the point of attachment of the whiffletrees. The bolt a' also extends through the upper side of said socket II , as shown at g^9 .

I designates a centrally-apertured removable cap placed upon the rear open end of the socket II , and J indicates an adjusting-screw inserted through the aperture i of said cap, axially through the chamber h of the socket and the internally-threaded adjusting-nut G^2 , arranged therein, and through a central aperture h^5 in the partition h^2 . The adjusting-screw J is threaded throughout the principal part of its length and has operative engagement with the threads of the nut G^2 , but the aperture h^5 is larger than the diameter of said screw and is unprovided with threads, so that the adjusting-screw is free to turn loosely therein.

In assembling the parts the adjusting-nut is placed within the chamber of the socket, the cap I placed upon the end of the latter, and the adjusting-screw inserted with its threaded inner end j extending through the partition h^2 . An ordinary nut J' is then placed upon said inner end, the exterior size of said nut J' being such as to permit it to turn freely within the chamber h' , and the nut is turned until the cap I is drawn to place, and the nut is brought into contact with the partition h^2 , but not so forcibly as to clamp the bolt from rotation. The end j of the bolt is then riveted down or upset upon the nut J' , so as to form, in effect, an inner head for the adjusting-bolt. After these parts have been thus assembled, the socket is secured upon the end of the pole, as described, sufficient space being left between the extreme rear end of the body of the pole and the nut J' to permit the latter to turn freely. Obviously, when thus assembled, turning the adjusting-screw in either direction, by means of a suitable wrench or spanner applied to the head end thereof, will cause the adjusting-nut G^2 to travel one way or the other within the chamber h . As the clip G is adjusted forwardly or toward the points of attachment

of the arms D with the body of the pole, the curvature of the bar E will obviously be increased and the distance between the shackles lessened, and, vice versa, when the clip is adjusted toward the end of the pole the bar E will be straightened and the shackles forced apart.

Next, describing the construction of the whiffletree connections, which also embody features of improvement, K designates a longitudinally-arranged top plate or strap secured to the upper side of the pole-body by means of bolts $a^1 a^2 a^3$, hereinbefore referred to, and provided with an aperture k for the hammer-bolt K^3 . The plate K is provided with a circular enlargement k' , surrounding the aperture k , which forms a bearing-surface upon which the whiffletree B rests and oscillates. The bearing-plate k' is provided with an annular vertical flange k^2 , forming a central hub surrounding the said aperture k , and with a second concentric-arranged flange k^3 , exterior to the flange k^2 .

K' designates a second bearing-plate secured to the under side of the whiffletree B, at the center thereof, said plate K' being provided with two concentric outer and inner flanges $k^4 k^5$, which are adapted to fit outside of and overlap the flanges $k^2 k^3$, respectively, of the plate K.

K^2 designates the hammer-strap proper, hinged at its rear end between two suitable lugs $k^6 k^6$ upon the upper side of the strap K, extending thence over the whiffletree and secured at its other end to the body of the pole by means of the bolt a^3 . The central part of the hammer-strap is provided with a hammer-bolt aperture k^7 , arranged to register with the corresponding aperture b of the whiffletree when the parts are properly assembled.

K^3 indicates the usual hammer-bolt inserted through the hammer-strap, the whiffletree, and pole, and secured in position by means of a retaining-nut k^8 upon the lower end thereof.

It will be noted that the flanges $k^2 k^4$ and $k^3 k^5$ overlap each other to a considerable extent, and that the whiffletree must therefore be raised some distance before said interfitted parts become separated, and by reason of this construction it will be apparent that should either bolt K^3 or a^3 become loosened, or even removed entirely, said whiffletree will be still held securely in place, and accidental separation thereby prevented. Moreover, the construction is such that the tendency of the whiffletree to rock in its bearings, by reason of the draft of the singletrees coming upon its upper side only, is most effectually prevented.

Substantially the same construction of interfitted bearing-plates is provided between the singletrees and whiffletree, and in order to counteract the tendency of the singletrees to rock or roll forward upon their bearings a novel hinged clevis construction is provided, as follows: L' designates an integral exten-

sion of the lower bearing-plate L, which extension is secured to the vertical rear side of the whiffletree and is provided with a hinged lug l , with which is engaged the bifurcated lower end of a clevis M. Said lower end of the clevis is provided with vertical bearing surfaces or shoulders $m m$, which are adapted to rest against the vertical rear face of the part L' and prevent the clevis from pivoting forward beyond a certain point. The clevis is so formed that when attached to the lug l of the part L' , with the vertical shoulder m in contact with the rear face thereof, its upper end will naturally assume the position indicated in dotted lines in Fig. 9, with its bolt-hole at the rear of the bolt, so that the clevis may be sprung forward and downward into position to engage the bolt and to contact with the top surface of the singletree when the draw-bolt or clevis-pin is inserted in position. The effect of this arrangement is beneficial in at least two respects: First, the spring of the clevis brings a strain upon the draw-bolt in a direction diagonally upwardly and rearwardly, in such a manner as to counteract the tendency of the singletree to roll forward under the draft of the tugs thereon, and, secondly, the tendency of the clevis to resume its natural shape keeps the parts under a tension which prevents rattling thereof.

In Figs. 13 and 14 I have shown a modification wherein the transverse brace-member E^2 is constructed of wood, and the clip G^4 is of modified form to conform to the same. In this instance the cross-sectional form of the member E^2 is generally rectangular, with the upper side thereof slightly rounded, as indicated clearly in said Fig. 14, and instead of being made in the form of a surrounding sleeve, the transverse part of the clip has the form of an inverted-U-shaped channel which fits over and embraces the opposite sides of the bar E^2 , the latter being secured therein by means of transverse bolts $e' e'$ and vertical bolts $e^2 e^2$.

It will be obvious from the foregoing description that a vehicle-pole constructed in accordance with my invention, while extremely simple and composed of relatively few parts, may be adjusted to fit any ordinary width between shackles with the utmost facility, and that in so adjusting it only an ordinary wrench or spanner is needed and not a single bolt, nut, or screw need be loosened or tightened, either before or after the adjustment is made. The wrench is simply applied to the head of the adjusting-screw and the latter turned one way or the other until the arms are brought to the required distance apart and the adjustment is complete. Furthermore, the parts are so constructed and arranged that the adjusting mechanism is practically entirely concealed within the pole, and to the eye of an ordinary observer the pole presents the same appearance as one unprovided with adjusting devices. This is a feature of much importance, as heretofore

such poles when provided with adjusting devices have been of more or less complicated construction and have been objectionable because involving such additional mechanism. In the present construction, on the contrary, the adjusting devices are all self-contained, and the exterior of the pole presents a uniform, smooth, and graceful appearance, and may be finished in any desired manner. Moreover, all of the parts seen when in use are immovable with relation to each other, and the finish of the pole will therefore not be marred by any change of adjustment.

I claim as my invention—

1. The combination with a vehicle-pole provided with rearwardly-divergent arms connected with the pole at points between its ends at opposite sides thereof, of a curved spring-bar extending transversely between said arms with its middle part transverse to the pole, said bar being rigidly attached at its ends to the arms and connected with the pole at the point at which it crosses the same, and means for adjusting the central part of said spring-bar longitudinally of the pole, substantially as described.

2. The combination with the vehicle-pole, of arms for connecting the pole with the vehicle, said arms comprising two outer members connected at their front ends with the pole at a point between the ends of the latter and arranged to extend in a rearward divergent direction, a spring-bar connected at its outer ends with the outer ends of said arms, and extending transversely of the pole, and a connecting device uniting the spring-bar with the pole having sliding connection with the pole, and embracing an adjusting-screw arranged longitudinally of the pole, and an adjusting-nut engaging said screw, substantially as described.

3. The combination with a vehicle-pole provided with rearwardly-divergent arms and a transversely-arranged curved spring-bar extending between said arms, a clip mounted to slide longitudinally of the pole and having a transverse socket to receive the spring-bar, an adjusting-screw mounted to extend longitudinally of the pole in bearings permitting rotary movement thereof, and an adjusting-nut threaded to travel upon said screw and connected with said clip, substantially as described.

4. The combination with a vehicle-pole provided with rearwardly-divergent arms and a transversely-arranged curved spring-bar extending between said arms, a clip mounted to slide longitudinally of the pole and having a transverse socket to receive the spring-bar, an adjusting-screw mounted to extend longitudinally of the pole in bearings permitting rotary movement thereof, and an adjusting-nut threaded to travel upon said screw and connected with said clip, said socket on the clip having clamping means to engage the bar, substantially as described.

5. The combination with a vehicle-pole pro-

vided with rearwardly-divergent arms and a transversely-arranged curved spring-bar rigidly united at its ends with the outer ends of said divergent arms and extending between the latter and across the rear end of the pole, and means for adjustably connecting said spring-bar with the pole, comprising a connecting-clip arranged to embrace said bar, an adjusting-nut mounted on said clip, a hollow slotted socket mounted longitudinally upon the pole, within which said adjusting-nut is arranged to slide, and an adjusting-screw arranged longitudinally within said socket and engaging said adjusting-nut, substantially as described.

6. The combination with a vehicle-pole provided with rearwardly-divergent arms and a transversely-arranged bar connected at its ends with the outer ends of said divergent arms, of means for adjustably connecting said transverse member with the body of the pole comprising a hollow tubular socket mounted upon the end of the pole, and provided with a longitudinally-arranged slot in one side thereof, an adjusting-screw revolvably mounted longitudinally within said socket, a connecting-clip arranged to engage the central part of the transverse member, provided with an adjusting-nut arranged to slide within said tubular socket and having engagement with said adjusting-screw, and a guide-bar rigidly connected with the clip and arranged to extend longitudinally of and slide upon the exterior of said tubular socket, substantially as described.

7. The combination with a vehicle-pole provided with rearwardly-divergent arms and a transversely-arranged bar connected at its ends with the outer ends of said divergent arms, of means for adjustably connecting the said transverse member with a part of the pole, comprising a hollow tubular socket mounted upon the end of the pole, having its interior divided by a transverse partition into rear and front chambers, and slotted at its lower side throughout the length of said chambers, a cap arranged to close the rear end of said rear chamber, an adjusting-screw extending through said cap and through the partition between the chambers, retaining-heads on each end of said adjusting-screw, a connecting-clip having a transverse sleeve portion arranged to embrace a part of the transverse member, an adjusting-nut mounted upon said adjusting-screw within the rear chamber and rigidly connected with the clip by means of a web extending through the slot of said tubular socket, and a guide-bar also rigidly connected with the clip and arranged to slide longitudinally upon the lower side of the tubular socket, said guide-bar being longitudinally slotted at its forward end, and engaged with a bolt arranged to extend vertically through the body of the pole, substantially as described.

8. In combination with a vehicle-pole provided with connecting-arms, each comprising

a rearwardly-extending divergent outer member and a transversely-arranged brace member, means for connecting said outer bar and brace member comprising a space-block arranged longitudinally between said members, said space-block and the outer bar and brace member being provided with longitudinal interfitting grooves and ribs, and a plurality of bolts extending transversely through said members and the interposed space-block, substantially as described.

9. The combination with a doubletree, of means for securing a singletree thereto, composing bearing-plates interposed between and attached to the singletree and the doubletree, interfitting annular flanges and grooves on said plates, an extension, as L', on the rear side of the plate that is placed upon the doubletree, said extension being substantially at right angles to the plate, a hinged lug on said extension, a clevis hinged at the lower end of said lug and arranged to extend at its

other end above the singletree, a draw-bolt passing vertically through the upper end of the clevis, and shoulders at the hinged end of the clevis adapted for contact with a part of the hinged support to limit the swinging of the clevis forward beyond a certain point, the clevis being so formed that when said shoulders are in engagement with the part of the hinged support, its upper end will stand at the rear of the position for engaging the bolt, whereby the clevis must be put under tension before the bolt can be inserted, substantially as described.

In testimony that I claim the foregoing as my invention I affix my signature, in presence of two witnesses, this 5th day of September, A. D. 1895.

NATHAN L. HOLMES.

Witnesses:

TAYLOR E. BROWN,
WILLIAM L. HALL.