



(12) **DEMANDE DE BREVET CANADIEN**  
**CANADIAN PATENT APPLICATION**

(13) **A1**

(86) Date de dépôt PCT/PCT Filing Date: 2020/06/24  
(87) Date publication PCT/PCT Publication Date: 2020/12/30  
(85) Entrée phase nationale/National Entry: 2021/12/29  
(86) N° demande PCT/PCT Application No.: US 2020/039231  
(87) N° publication PCT/PCT Publication No.: 2020/263885  
(30) Priorité/Priority: 2019/06/27 (US16/455,215)

(51) Cl.Int./Int.Cl. *B65D 5/54* (2006.01)  
(71) Demandeur/Applicant:  
WESTROCK SHARED SERVICES, LLC, US  
(72) Inventeur/Inventor:  
SIMPKINS, KEVIN M., US  
(74) Agent: MARKS & CLERK

(54) Titre : CARTON D'EXPEDITION A PROFONDEUR VARIABLE  
(54) Title: SHIPPERS WITH VARIABLE DEPTH

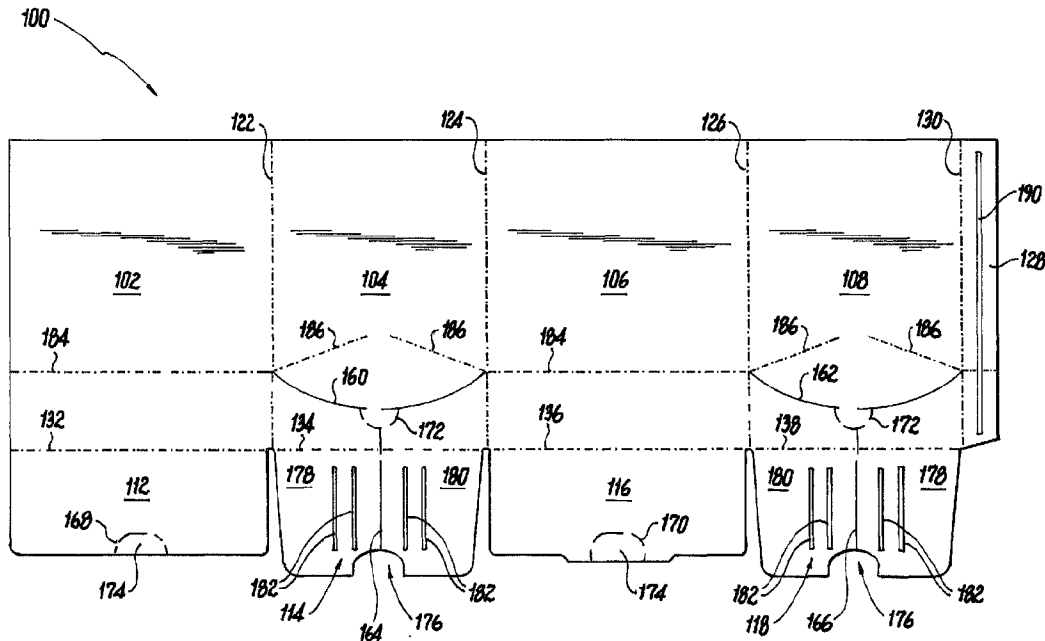

**Fig. 1**

(57) **Abrégé/Abstract:**

A container includes a first blank and a second blank. The first blank includes a plurality of panels foldably connected to one another and erected about an interior space, and a plurality of top flaps foldably connected to the plurality of panels to enclose a top end of the interior space. The second blank includes a bottom panel affixed to the first blank opposite the top flaps to enclose a bottom end of the interior space. The first blank includes a line of weakness pattern configured to allow a user to break the top flaps from a closed configuration enclosing the interior space to an open configuration allowing access to the interior space.

(12) INTERNATIONAL APPLICATION PUBLISHED UNDER THE PATENT COOPERATION TREATY (PCT)

(19) World Intellectual Property  
Organization  
International Bureau



(10) International Publication Number  
**WO 2020/263885 A1**

(43) International Publication Date  
30 December 2020 (30.12.2020)

- (51) International Patent Classification:  
B65D 5/54 (2006.01)
- (21) International Application Number:  
PCT/US2020/039231
- (22) International Filing Date:  
24 June 2020 (24.06.2020)
- (25) Filing Language:  
English
- (26) Publication Language:  
English
- (30) Priority Data:  
16/455,215 27 June 2019 (27.06.2019) US
- (71) Applicant: WESTROCK SHARED SERVICES, LLC  
[US/US]; 1000 Abernathy Road NE, Atlanta, Georgia  
30328 (US).
- (72) Inventor: SIMPKINS, Kevin M.; 2150 Highland Gate  
Drive, Cumming, Georgia 30040 (US).

(74) Agent: COHEN, Neil et al.; Westrock Company, 501 South  
5th Street, Richmond, Virginia 23219-0501 (US).

(81) Designated States (unless otherwise indicated, for every  
kind of national protection available): AE, AG, AL, AM,  
AO, AT, AU, AZ, BA, BB, BG, BH, BN, BR, BW, BY, BZ,  
CA, CH, CL, CN, CO, CR, CU, CZ, DE, DJ, DK, DM, DO,  
DZ, EC, EE, EG, ES, FI, GB, GD, GE, GH, GM, GT, HN,  
HR, HU, ID, IL, IN, IR, IS, JO, JP, KE, KG, KH, KN, KP,  
KR, KW, KZ, LA, LC, LK, LR, LS, LU, LY, MA, MD, ME,  
MG, MK, MN, MW, MX, MY, MZ, NA, NG, NI, NO, NZ,  
OM, PA, PE, PG, PH, PL, PT, QA, RO, RS, RU, RW, SA,  
SC, SD, SE, SG, SK, SL, ST, SV, SY, TH, TJ, TM, TN, TR,  
TT, TZ, UA, UG, US, UZ, VC, VN, WS, ZA, ZM, ZW.

(84) Designated States (unless otherwise indicated, for every  
kind of regional protection available): ARIPO (BW, GH,  
GM, KE, LR, LS, MW, MZ, NA, RW, SD, SL, ST, SZ, TZ,  
UG, ZM, ZW), Eurasian (AM, AZ, BY, KG, KZ, RU, TJ,  
TM), European (AL, AT, BE, BG, CH, CY, CZ, DE, DK,  
EE, ES, FI, FR, GB, GR, HR, HU, IE, IS, IT, LT, LU, LV,  
MC, MK, MT, NL, NO, PL, PT, RO, RS, SE, SI, SK, SM,

(54) Title: SHIPPERS WITH VARIABLE DEPTH

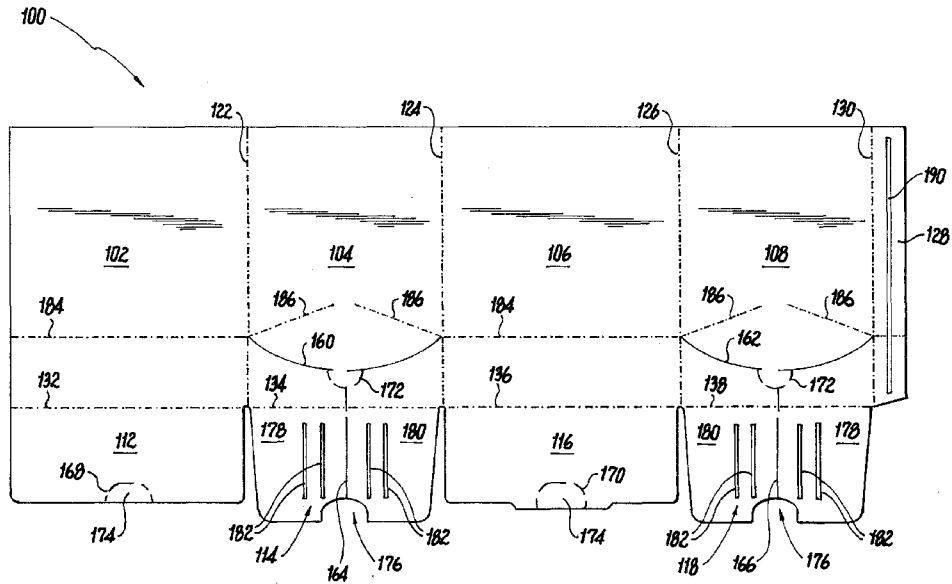

**Fig. 1**

(57) Abstract: A container includes a first blank and a second blank. The first blank includes a plurality of panels foldably connected to one another and erected about an interior space, and a plurality of top flaps foldably connected to the plurality of panels to enclose a top end of the interior space. The second blank includes a bottom panel affixed to the first blank opposite the top flaps to enclose a bottom end of the interior space. The first blank includes a line of weakness pattern configured to allow a user to break the top flaps from a closed configuration enclosing the interior space to an open configuration allowing access to the interior space.



WO 2020/263885 A1

**WO 2020/263885 A1** 

---

TR), OAPI (BF, BJ, CF, CG, CI, CM, GA, GN, GQ, GW,  
KM, ML, MR, NE, SN, TD, TG).

**Published:**

— *with international search report (Art. 21(3))*

## SHIPPERS WITH VARIABLE DEPTH

### **REFERENCE TO RELATED APPLICATION**

5 This application claims the benefit of priority under 35 U.S.C. §119(e) of United States  
xxx application serial number 16/455215 filed on June 27, 2019, which is hereby incorporated by  
reference in its entirety.

### **BACKGROUND**

#### **1. Field**

10 The present disclosure relates to shipping containers, and more particularly to  
shipping containers with features to allow for custom sizing, opening or unboxing  
experience for the end user, and the like.

#### **2. Description of Related Art**

15 Products that up until recently were almost exclusively purchased in a physical retail  
setting are increasingly available to consumers through ecommerce vendors that ship the  
products directly to the consumer. For shipping purposes there is a concomitant shift from  
shipping in bulk to shipping products on an individual basis. Traditionally, ecommerce products  
are packed in standard boxes with standard packing such as bubble wrap as needed.

20 The conventional techniques have been considered satisfactory for their intended  
purpose. However, there is an ever present need for improved packaging, e.g. for shipping  
ecommerce products and the like. This disclosure provides a solution for this need.

## SUMMARY

A container includes a first blank and a second blank. The first blank includes a plurality of panels foldably connected to one another and erected about an interior space, and a plurality of top flaps foldably connected to the plurality of panels to enclose a top end of the interior space.

5 The second blank includes a bottom panel affixed to the first blank opposite the top flaps to enclose a bottom end of the interior space. The first blank includes a line of weakness pattern configured to allow a user to break the top flaps from a closed configuration enclosing the interior space to an open configuration allowing access to the interior space.

10 The plurality of panels can include a front panel, a first side panel, a back panel opposed to the front panel, and a second side panel opposed to the first side panel. The second blank can include a front flap foldably connected to the bottom panel and adhered to the front panel of the first blank, a back flap foldably connected to the bottom panel and adhered to the back panel of the first blank, a first side flap foldably connected to the bottom panel and adhered to the first side panel of the first blank, and a second side flap foldably connected to the bottom panel and  
15 adhered to the second side panel of the first blank.

The top flaps, the first side panel, and the second side panel can include perforations of the line of weakness pattern. The perforations in the first and second side panels can define a respective opener tab in each of the first and second side panels configured for a user to initiate breaking the line of weakness pattern. The perforations in the top flaps can define a top opener  
20 feature configured for a user to initiate breaking the top flaps. The perforations in the first and second side panels can follow respective arcuate paths. Each of the front and back panels can include a respective hinge line defined therein for hinging the first blank into the open configuration. Each hinge line can extend into each of the first and second side panels.

The top flaps can include a back top flap foldably connected to the back panel, a front top flap foldably connected to the front panel, a first side top flap foldably connected to the first side panel, and a second side top flap foldably connected to the second side panel. The line of weakness pattern can include respective perforations from each respective opener tab and across each respective one of the first and second side top flaps. The perforations across each respective one of the first and second side top flaps can each connect between a respective one of the opener tabs to an edge notch in the respective one of the first and second side top flaps. The top opener feature can be aligned with the edge notches of the first and second side top flaps. The perforations across each respective one of the first and second side top flaps can divide each of the first and second side top flaps into a front portion and a back portion, wherein the front portions are adhered to the front top flap, and wherein the back portions are adhered to the back top flap.

In another aspect, it is also contemplated that the top flaps and the front panel can include perforations of the line of weakness pattern. The perforation in the front panel can define an opening tab configured for a user to initiate breaking the line of weakness pattern. The top flaps can include a back top flap foldably connected to the back panel, a front top flap foldably connected to the front panel, a first side top flap foldably connected to the first side panel, and a second side top flap foldably connected to the second side panel, wherein the line of weakness pattern includes perforations in the front top flap, the first side top flap, and the second side top flap. The perforation in the first side top flap can divide the first side top flap into a breakaway portion adhered to the top back flap and a non-breakaway portion adhered to a non-breakaway portion of the front top flap. The perforation in the second side top flap can divide the second side top flap into a breakaway portion adhered to the top back flap and a non-breakaway portion

adhered to a non-breakaway portion of the front top flap. A breakaway portion of the front top flap can be adhered to the breakaway portions of the first and second side top flaps.

A blank system for container includes a first blank with a plurality of panels foldably connected to one another configured to be erected about an interior space, and a plurality of top flaps foldably connected to the plurality of panels configured to enclose a top end of the interior space. The blank system also includes a second blank including a bottom panel configured to be affixed to the first blank opposite the top flaps to enclose a bottom end of the interior space, wherein the first blank includes a line of weakness pattern configured to allow break the top flaps from a closed configuration enclosing the interior space to an open configuration allowing access to the interior space.

A method includes packaging a plurality of product items into respective containers. For each container, packaging includes forming a first blank around a mandrel to surround an interior space with a plurality of panels, adhering top flaps of the first blank to enclose a top end of the interior space, cutting the plurality of panels to a custom length, placing product inside the interior space, and affixing a second blank to the first blank to enclose a bottom end of the interior space with the product inside the interior space, wherein the first blank includes a line of weakness pattern configured to allow break the top flaps from a closed configuration enclosing the interior space to an open configuration allowing access to the interior space.

For each respective container, the method can include cutting the plurality of panels to a custom length before affixing the second blank thereto, wherein the custom length varies from container to container.

Another method includes opening a container that includes a first blank including a plurality of panels foldably connected to one another and erected about an interior space, and a

plurality of top flaps foldably connected to the plurality of panels to enclose a top end of the interior space, and a second blank including a bottom panel affixed to the first blank opposite the top flaps to enclose a bottom end of the interior space, wherein the first blank includes a line of weakness pattern configured to allow break the top flaps from a closed configuration enclosing the interior space to an open configuration allowing access to the interior space. Opening includes breaking the line of weakness pattern and hinging the top flaps into the open configuration.

Breaking the line of weakness pattern can include breaking an opening tab in each of the first and second side panels, breaking an opening feature in the top flaps, gripping the opening feature to break the top flaps, and hinging the top flaps into the open configuration along hinge lines defined in the front and back panels. It is also contemplated that breaking the line of weakness pattern can include breaking an opening tab in the front panel, breaking perforations in the front top flap and the first and second side top flaps, and hinging the back flap into the open configuration along a fold line connecting the back flap to the back panel.

These and other features of the systems and methods of the subject disclosure will become more readily apparent to those skilled in the art from the following detailed description of the preferred embodiments taken in conjunction with the drawings.

**BRIEF DESCRIPTION OF THE DRAWINGS**

So that those skilled in the art to which the subject disclosure appertains will readily understand how to make and use the devices and methods of the subject disclosure without undue experimentation, preferred embodiments thereof will be described in detail herein below with reference to certain figures, wherein:

Fig. 1 is a plan view of an embodiment of a first blank constructed in accordance with the present disclosure, showing the panels, flaps, and line of weakness pattern;

Fig. 2 is a plan view of an embodiment of a second blank constructed in accordance with the present disclosure, showing the bottom panel and flaps;

Fig. 3 is a perspective view of a container constructed from the first and second blanks of Figs. 1 and 2, showing a first stage in opening the container;

Fig. 4 is a perspective view of the container of Fig. 3, showing a second stage of opening the container;

Fig. 5 is a schematic view of a method of making the container of Fig. 3;

Fig. 6 is a plan view of another embodiment of a first blank constructed in accordance with the present disclosure; and

Fig. 7 is a perspective view of a container constructed from the first blank of Fig. 6 and a second blank as in Fig. 2, showing the container after opening.

## **DETAILED DESCRIPTION OF THE PREFERRED EMBODIMENTS**

Reference will now be made to the drawings wherein like reference numerals identify similar structural features or aspects of the subject disclosure. For purposes of explanation and illustration, and not limitation, a partial view of an embodiment of a blank for a container in accordance with the disclosure is shown in Fig. 1 and is designated generally by reference character 100. Other embodiments of systems in accordance with the disclosure, or aspects thereof, are provided in Figs. 2-7, as will be described. The systems and methods described herein can be used to provide custom sized shippers for products, e.g., for use in automated e-commerce packaging and shipping, which can provide an opening or unboxing experience for the end user.

The first blank 100 includes a plurality of panels 102, 104, 106, 108 foldably connected to one another and erected about an interior space 110 (indicated in Figs. 4-5). A plurality of top flaps 112, 114, 116, 118 are foldably connected to the plurality of panels 102, 104, 106, 108 to enclose a top end 120 (indicated in Figs. 3-4) of the interior space 110. The plurality of panels 102, 104, 106, 108 include a front panel 102 foldably connected to a first side panel 104 along a fold line 122, a back panel 106 opposed to the front panel 102 and foldably connected to the first side panel 104 along a fold line 124, and a second side panel 108 opposed to the first side panel 104 foldably connected to the back panel 106 along a fold line 126. An adhesive flap 128 is foldably connected to the second side panel 108 along a fold line 130 opposite the fold line 126.

The top flaps 112, 114, 116, 118 include a front top flap 112 foldably connected to the front panel 102 along a fold line 132, a back top flap 116 foldably connected to the back panel 106 along a fold line 136, a first side top flap 114 foldably connected to the first side panel 104

along a fold line 134, and a second side top flap 118 foldably connected to the second side panel 108 along a fold line 138 (where fold lines 132, 134, 136, 138 are optionally collinear).

Referring now to Fig. 2, the second blank 140 includes a bottom panel 150 having a front flap 142 foldably connected to the bottom panel 150 along a fold line 152 and ultimately adhered to the front panel 102 of the first blank 100 (as shown in Figs. 3-5), a back flap 146 foldably connected to the bottom panel 150 along a fold line 156 and ultimately adhered to the back panel 106 of the first blank 100 (as shown in Figs. 3-5), a first side flap 144 foldably connected to the bottom panel 150 along fold line 154 and ultimately adhered to the first side panel 104 of the first blank 100 (as shown in Figs. 3-5), and a second side flap 148 foldably connected to the bottom panel 150 along a fold line 158 and ultimately adhered to the second side panel 108 of the first blank 100 (as shown in Figs. 3-5). The two blanks, 100 and 140 can be made separately and sold together, e.g., in palletized form, to be ultimately formed and joined into a container 101 as shown in Figs. 3-5.

With reference again to Fig. 1, the first blank includes a line of weakness pattern. The top flaps 112, 114, 116, 118, the first side panel 104, and the second side panel 108 include perforations 160, 162, 164, 166, 168, 170 of the line of weakness pattern. The perforations 160, 162 in the first and second side panels 104, 108 follow respective arcuate paths and define at their apices respective opener tabs 172 in each of the first and second side panels 104, 108 configured for a user to initiate breaking the line of weakness pattern. The perforations 168, 170 in the top flaps 112, 116 define a top opener feature 174 configured for a user to initiate breaking the top flaps 112, 114, 116, 118.

The line of weakness pattern includes respective perforations 164, 166 from each respective opener tab 172 and across each respective one of the first and second side top flaps

114, 118. The perforations 164, 166 across each respective one of the first and second side top flaps 114, 118 can each connect between a respective one of the opener tabs 172 to an edge notch 176 in the respective one of the first and second side top flaps 114, 118. The top opener feature 174 is aligned with the edge notches 176 when the container 101 is formed, as shown in Fig. 3. The perforations 164, 166 divide each of the first and second side top flaps 114, 118 into a front portion 178 and a back portion 180. The front portions 178 are ultimately adhered to the front top flap 112, e.g., using adhesive lines 182, and the back portions 180 are adhered to the back top flap 116, e.g. using the adhesive lines 182, to form the container 101 shown in Fig. 3.

Each of the front and back panels 102, 106 includes a respective hinge line 184 defined therein for hinging the first blank 100 into the open configuration shown in Fig. 4. Each hinge line 184 extends into each of the first and second side panels 104, 108 as oblique fold lines 186 which facilitate opening the container 101 into the open configuration shown in Fig. 4.

With reference now to Fig. 5, a method includes packaging a plurality of product items into respective containers 101. For each container 101, packaging includes (as indicated in stages 1 and 2 of Fig. 5) forming a first blank 100 as described above around a mandrel 188 to surround the interior space 110 as shown in Figs. 3-4. The adhesive flap 128 can be adhered to the front panel 102 using adhesive line 190 (labeled in Fig. 1). The top flaps 112, 116 can be adhered outside of the top flaps 114, 118 using the adhesive lines 182 (labeled in Fig. 1). If desirable to fit the shipment of product to be contained in the container 101, the plurality of panels 102, 104, 106, 108 can be cut to a custom length by shortening the lower end 192 thereof as indicated in stages 3 and 4 in Fig. 5, e.g. using a box sizing machine. In Fig. 5 stage 4, it is schematically indicated that the lower end 192 is separated from the blank 100, however those skilled in the art will readily appreciate that the lower end 192 can be scored/cut and folded

down into the interior space 110, e.g. by folding 90 degrees. The second blank 140 can be affixed to the first blank 100 to enclose a bottom end 192 of the interior space 110, by adhering the respective flaps 142, 144, 146, 148 to the respective panels 102, 104, 106, 108 as indicated in stages 5 and 6 of Fig. 5. Product can be placed inside the interior space 110, e.g. after the mandrel 188 is removed in stage 3 of in Fig. 5, so that the product is packaged inside the interior space 110 at stage 6 of Fig. 5. For each respective container 101, the method can include cutting the plurality of panels 102, 104, 106, 108 (e.g. at stage 3 of Fig. 5) to a custom length to fit a custom shipment of product (e.g., as in a fulfillment center in ecommerce) before affixing the second blank 140 thereto, wherein the custom length varies from container 101 to container 101.

With reference now to Fig. 3, and end user can open the container 101 by breaking the line of weakness pattern described above and hinging the top flaps 112, 114, 116, 118 into the open configuration shown in Fig. 4. Breaking the line of weakness pattern can be initiated by breaking the opening tab 172 in each of the first and second side panels 104, 108, and breaking the perforations 160, 162 (labeled in Fig. 1) as facilitated by the fold line portions 186 (labeled in Fig. 1) and indicated by the large, outward pointing arrows in Fig. 3. Then the end user can break the opening feature 174 in the top flaps, gripping the opening feature 174 (e.g. by manually gripping the edge of notches 176, labeled in Fig. 1, and pulling apart as indicated by the large outward facing arrows in Fig. 4) to break the top flaps 114, 118 along perforation lines 164 and 166. This allows hinging the top flaps 112, 114, 116, 118 and upper portions of the panels 102, 104, 106, 108 into the open configuration along the hinge lines 184 as shown in Fig. 4. The end user can then remove a product item or items from the interior space 110.

With reference now to Fig. 6, another embodiment of a first blank 200 is shown with panels 202, 204, 206, 208 and top flaps 212, 214, 216, 218, and adhesive flap 228 foldably

connected together much as described above with respect to Fig. 1. There is a line of weakness defined the top flaps 212, 214, 216, 218 and the front panel 202 that include perforations 260, 264, 266. The perforation 260 in the front panel 202 defines an opening tab 272 configured for a user to initiate breaking the line of weakness pattern. The line of weakness pattern includes perforation 260 in the front top flap 212 and front panel 202, and respective perforations 264, 266 in the first side top flap 214 and the second side top flap 218. The perforation 264 in the first side top flap 214 divides the first side top flap 214 into a breakaway portion 278 adhered to the top back flap 216 with adhesive 282 (and adhered to a breakaway portion 298 of the front top flap 212 with adhesive 283) and a non-breakaway portion 280 adhered to a non-breakaway portion 294 of the front top flap 212 with adhesive 285. The perforation 266 in the second side top flap 218 divides the second side top flap 218 into a breakaway portion 278 adhered to the top back flap 216 with adhesive 282 (and adhered to the breakaway portion 298 the front top flap 212 with adhesive 283) and a non-breakaway portion 280 adhered to a non-breakaway portion 296 of the front top flap 212. The container 201 shown in Fig. 7 can be formed using a similar process to that described above with respect to Fig. 5, observing the adhesions outlined above with respect to blank 200, and using the same second blank 140 shown in Fig. 2.

With continued reference to Fig. 7, the end user can open the container 201 by breaking the line of weakness pattern. This includes breaking the opening tab 272 in the front panel 202, breaking perforations 260, 264, 266 (labeled in Fig. 6), and hinging the back flap 216 along fold line 236 (connecting between the back panel 206 and the back top panel 216) into the open configuration.

Those skilled in the art will readily appreciate that the width and depth dimensions of the containers 101, 201 can readily be change as suitable for a given application. While described

herein in the exemplary context of perforations, those skilled in the art will readily appreciate that any suitable type or combination of types of lines of weakness can be used such as but not limited to score lines, cut lines, partial depth cut lines, crush lines, and the like. It is contemplated that any suitable product type can be shipped in containers as disclosed herein, such as but not limited to clothing, essential oils, lightweight electronics, small parts, non-perishables, and the like. Additionally, systems and methods as disclosed herein allow the packer or ecommerce shipper to vary the height on a container by container basis based on the contents.

The methods and systems of the present disclosure, as described above and shown in the drawings, provide for custom sized shippers for products, e.g., for use in automated ecommerce packaging and shipping, which can provide an opening or unboxing experience for the end user. While the apparatus and methods of the subject disclosure have been shown and described with reference to preferred embodiments, those skilled in the art will readily appreciate that changes and/or modifications may be made thereto without departing from the scope of the subject disclosure.

**What is claimed is:**

1. A container comprising:

a first blank including a plurality of panels foldably connected to one another and erected about an interior space, and a plurality of top flaps foldably connected to the plurality of panels  
5 to enclose a top end of the interior space; and

a second blank including a bottom panel affixed to the first blank opposite the top flaps to enclose a bottom end of the interior space, wherein the first blank includes a line of weakness pattern configured to allow a user to break the top flaps from a closed configuration enclosing the interior space to an open configuration allowing access to the interior space.  
10

2. The container as recited in claim 1, wherein the plurality of panels include a front panel, a first side panel, a back panel opposed to the front panel, and a second side panel opposed to the first side panel, and wherein the second blank further comprises a front flap foldably connected to the bottom panel and adhered to the front panel of the first blank, a back flap foldably  
15 connected to the bottom panel and adhered to the back panel of the first blank, a first side flap foldably connected to the bottom panel and adhered to the first side panel of the first blank, and a second side flap foldably connected to the bottom panel and adhered to the second side panel of the first blank.

3. The container as recited in claim 1, wherein the top flaps, the first side panel, and the  
20 second side panel include perforations of the line of weakness pattern.

4. The container as recited in claim 3, wherein the perforations in the first and second side panels define a respective opener tab in each of the first and second side panels configured for a user to initiate breaking the line of weakness pattern.

5 5. The container as recited in claim 4, wherein the perforations in the top flaps define a top opener feature configured for a user to initiate breaking the top flaps.

6. The container as recited in claim 5, wherein the perforations in the first and second side panels follow respective arcuate paths.

10

7. The container as recited in claim 5, wherein each of the front and back panels includes a respective hinge line defined therein for hinging the first blank into the open configuration.

15

8. The container as recited in claim 7, wherein each hinge line extends into each of the first and second side panels.

20

9. The container as recited in claim 5, wherein the top flaps include a back top flap foldably connected to the back panel, a front top flap foldably connected to the front panel, a first side top flap foldably connected to the first side panel, and a second side top flap foldably connected to the second side panel, wherein the line of weakness pattern includes respective perforations from each respective opener tab and across each respective one of the first and second side top flaps.

10. The container as recited in claim 9, wherein the perforations across each respective one of the first and second side top flaps each connect between a respective one of the opener tabs to an edge notch in the respective one of the first and second side top flaps.

5 11. The container as recited in claim 10, wherein the top opener feature is aligned with the edge notches of the first and second side top flaps.

12. The container as recited in claim 10, wherein the perforations across each respective one of the first and second side top flaps divide each of the first and second side top flaps into a front  
10 portion and a back portion, wherein the front portions are adhered to the front top flap, and wherein the back portions are adhered to the back top flap.

13. The container as recited in claim 1, wherein the top flaps and the front panel include perforations of the line of weakness pattern.

15

14. The container as recited in claim 13, wherein the perforation in the front panel defines an opening tab configured for a user to initiate breaking the line of weakness pattern.

15. The container as recited in claim 14, wherein the top flaps include a back top flap  
20 foldably connected to the back panel, a front top flap foldably connected to the front panel, a first side top flap foldably connected to the first side panel, and a second side top flap foldably connected to the second side panel, wherein the line of weakness pattern includes perforations in the front top flap, the first side top flap, and the second side top flap.

16. The container as recited in claim 15, wherein the perforation in the first side top flap divides the first side top flap into a breakaway portion adhered to the top back flap and a non-breakaway portion adhered to a non-breakaway portion of the front top flap, wherein the perforation in the second side top flap divides the second side top flap into a breakaway portion adhered to the top back flap and a non-breakaway portion adhered to a non-breakaway portion of the front top flap, and wherein a breakaway portion of the front top flap is adhered to the breakaway portions of the first and second side top flaps.

17. A blank system for container comprising:

a first blank including a plurality of panels foldably connected to one another configured to be erected about an interior space, and a plurality of top flaps foldably connected to the plurality of panels configured to enclose a top end of the interior space; and

a second blank including a bottom panel configured to be affixed to the first blank opposite the top flaps to enclose a bottom end of the interior space, wherein the first blank includes a line of weakness pattern configured to allow break the top flaps from a closed configuration enclosing the interior space to an open configuration allowing access to the interior space.

18. A method comprising:

packaging a plurality of product items into respective containers, wherein for each container, packaging includes:

forming a first blank around a mandrel to surround an interior space with a plurality of panels;

adhering top flaps of the first blank to enclose a top end of the interior space;

cutting the plurality of panels to a custom length;

5 placing product inside the interior space; and

affixing a second blank to the first blank to enclose a bottom end of the interior space with the product inside the interior space, wherein the first blank includes a line of weakness pattern configured to allow break the top flaps from a closed configuration enclosing the interior space to an open configuration allowing access to the interior space.

10

19. The method as recited in claim 18, further comprising for each respective container, cutting the plurality of panels to a custom length before affixing the second blank thereto, wherein the custom length varies from container to container.

15

20. A method comprising:

opening a container that includes:

a first blank including a plurality of panels foldably connected to one another and erected about an interior space, and a plurality of top flaps foldably connected to the plurality of panels to enclose a top end of the interior space; and

20

a second blank including a bottom panel affixed to the first blank opposite the top flaps to enclose a bottom end of the interior space, wherein the first blank includes a line of weakness pattern configured to allow break the top flaps from a closed configuration enclosing the interior space to an open configuration allowing access to the interior space;

wherein opening includes breaking the line of weakness pattern and hinging the top flaps into the open configuration.

21. The method as recited in claim 20, wherein breaking the line of weakness pattern  
5 includes:

breaking an opening tab in each of the first and second side panels;

breaking an opening feature in the top flaps;

gripping the opening feature to break the top flaps; and

hinging the top flaps into the open configuration along hinge lines defined in the front

10 and back panels.

22. The method as recited in claim 20, wherein breaking the line of weakness pattern  
includes:

breaking an opening tab in the front panel;

15 breaking perforations in the front top flap and the first and second side top flaps; and

hinging the back flap into the open configuration along a fold line connecting the back  
flap to the back panel.

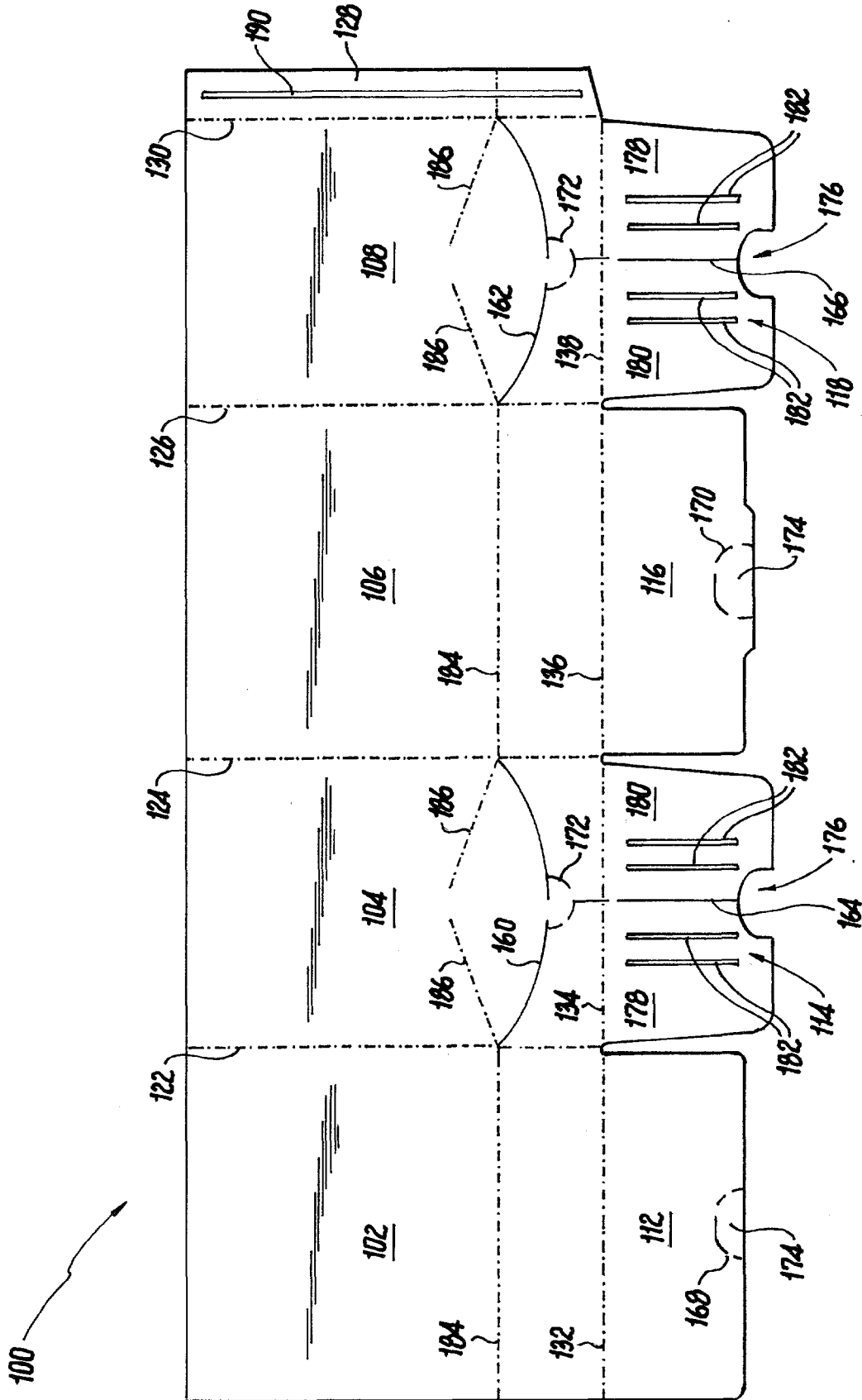
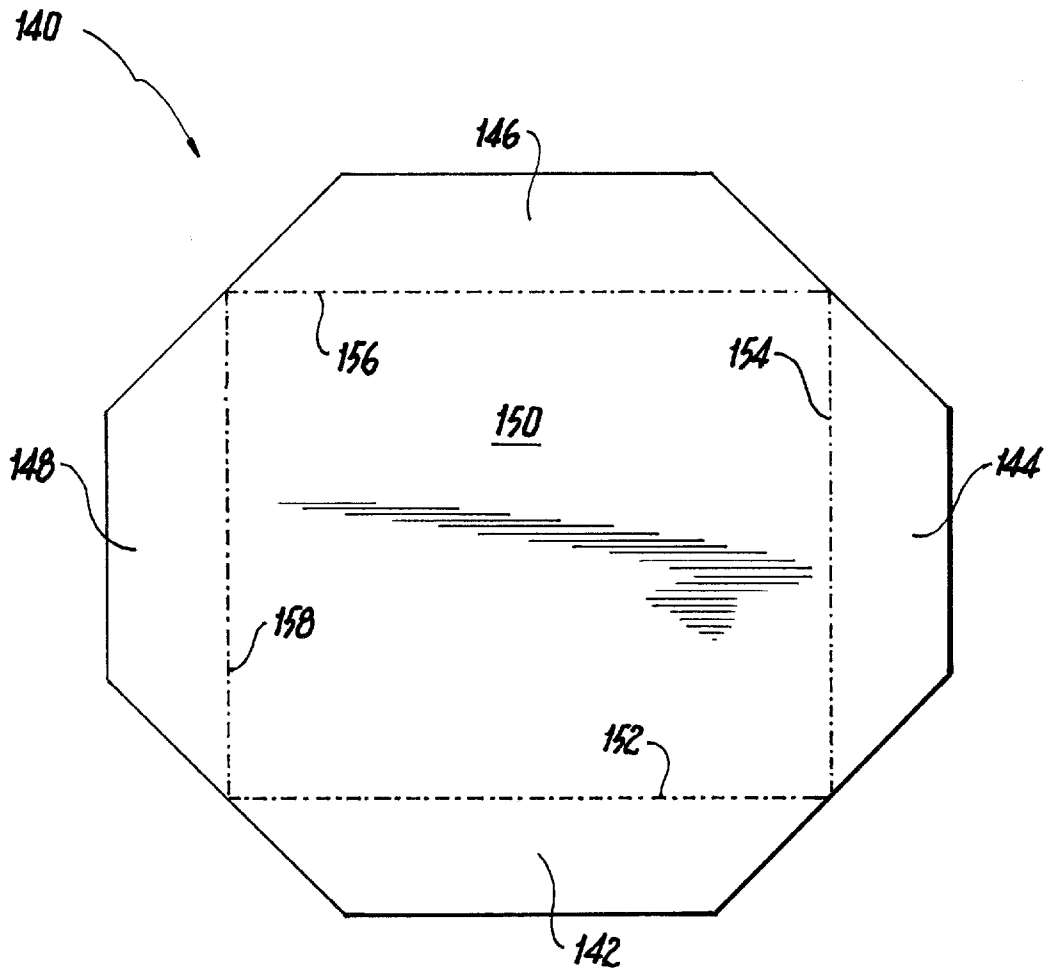
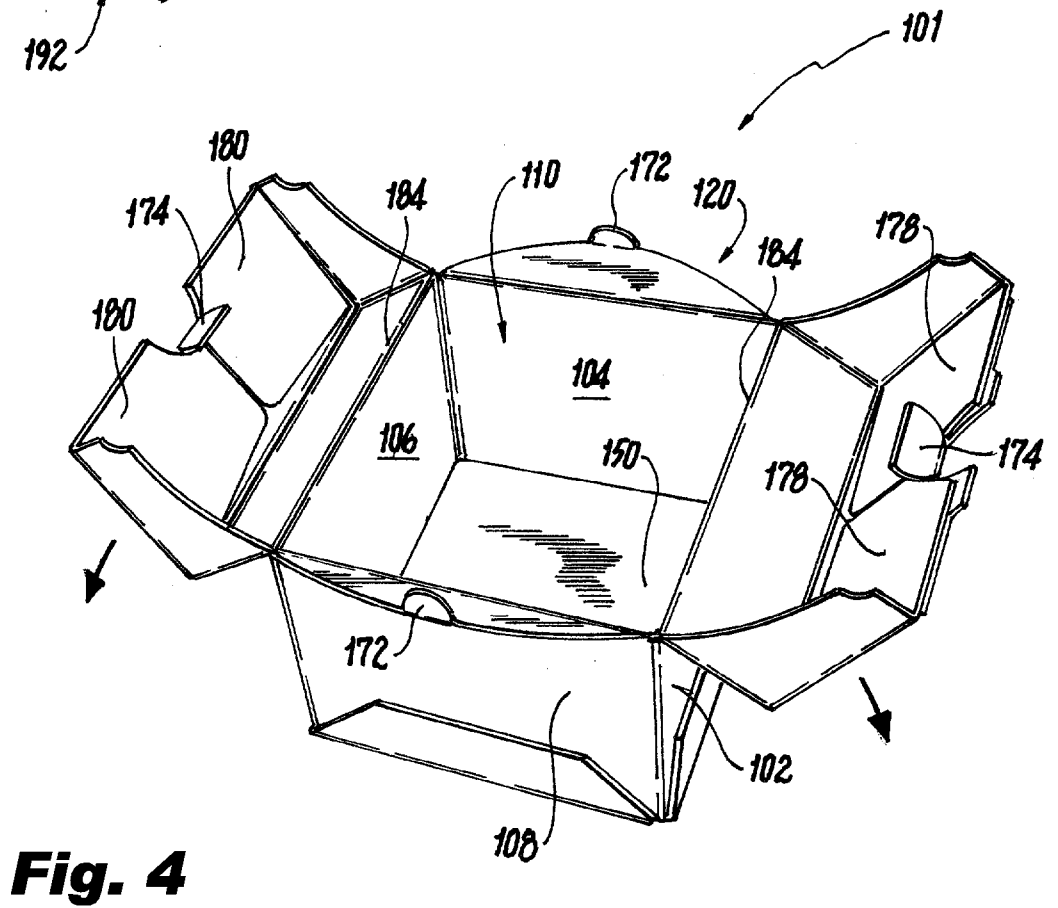
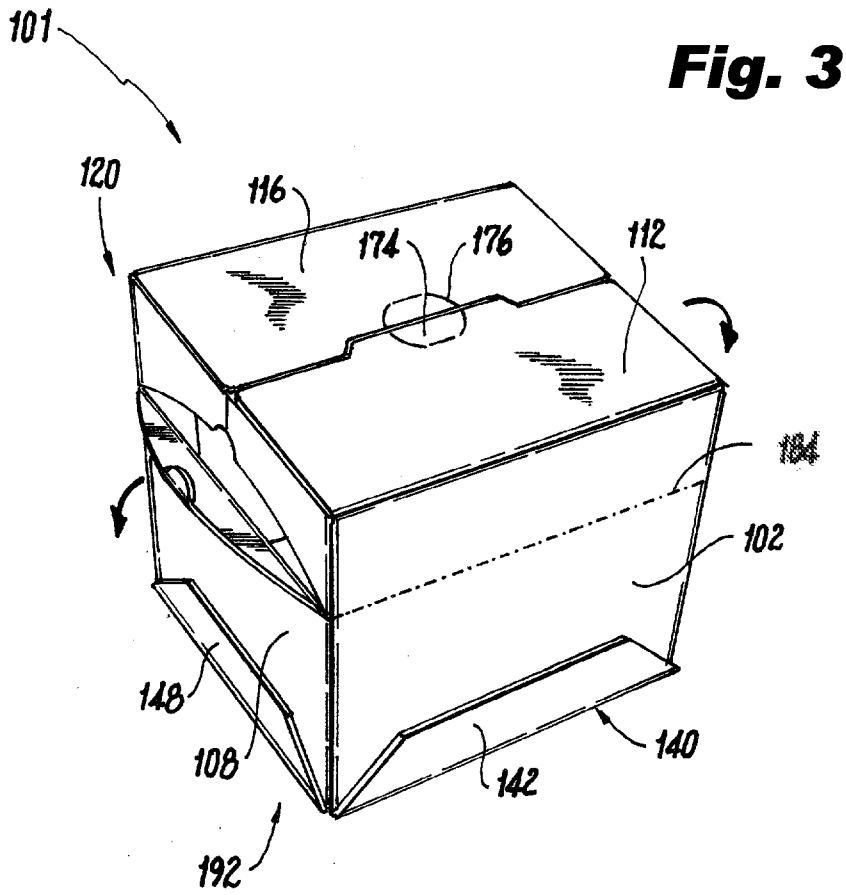
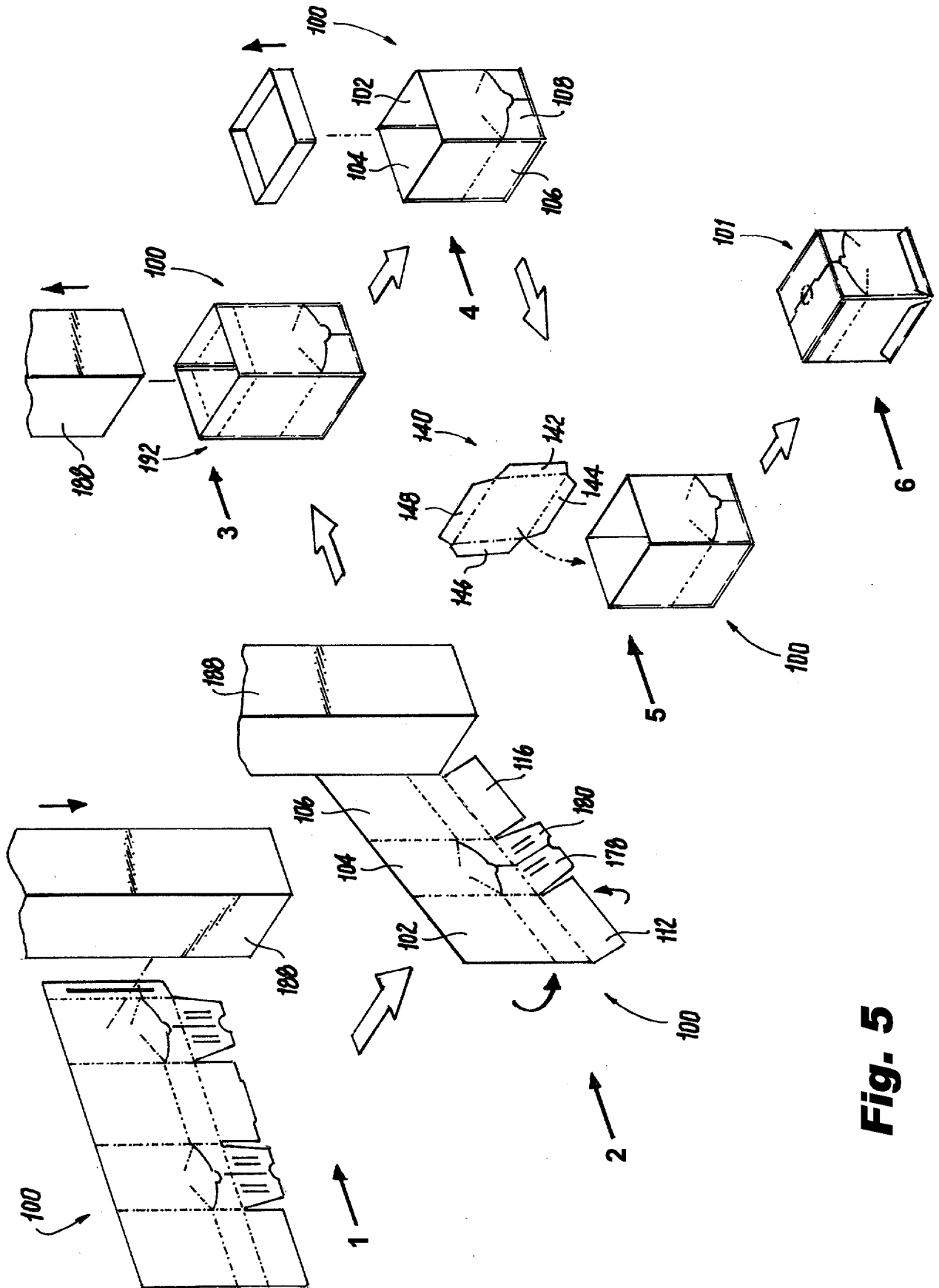

Fig. 1



**Fig. 2**





**Fig. 5**

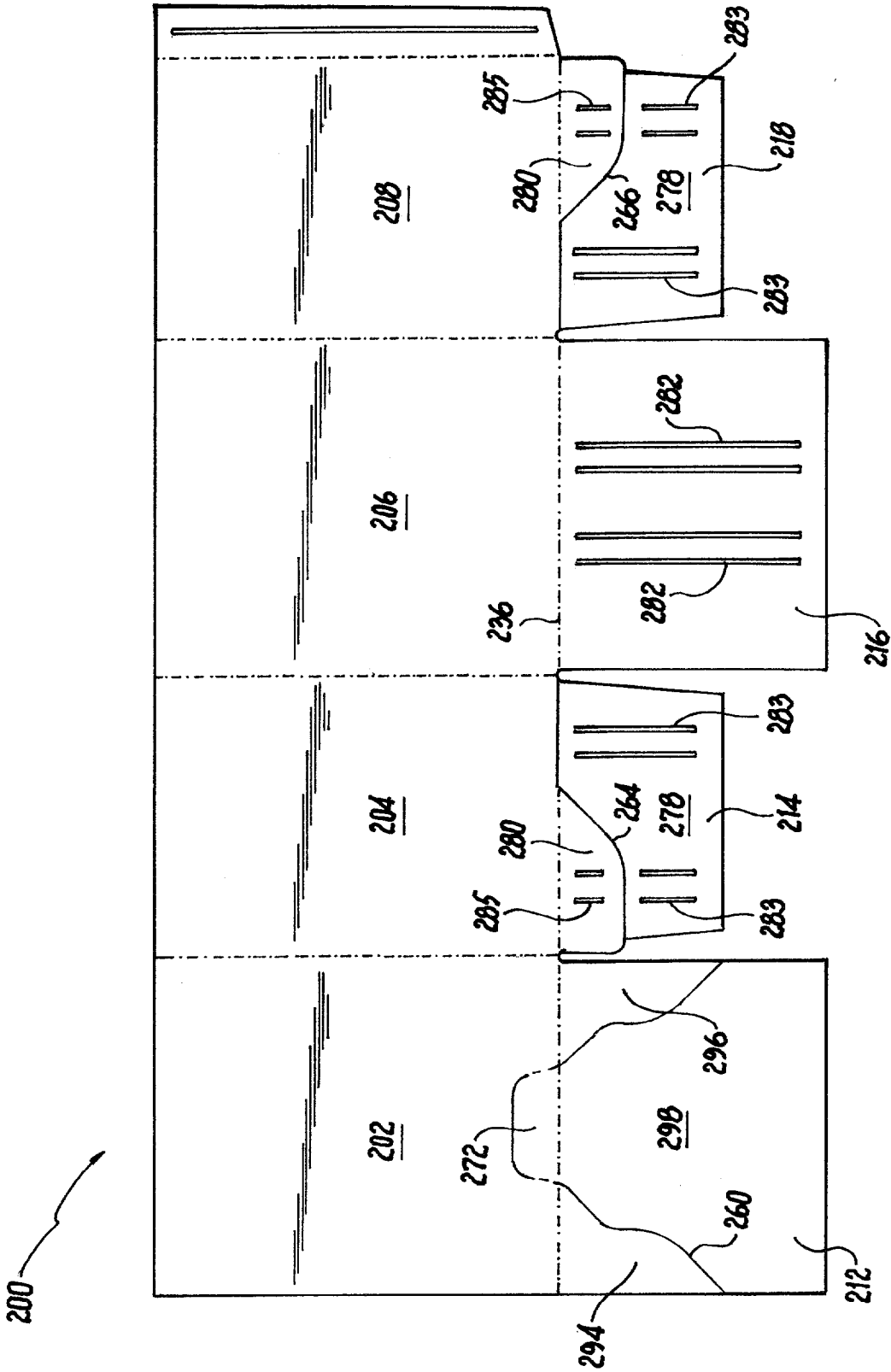
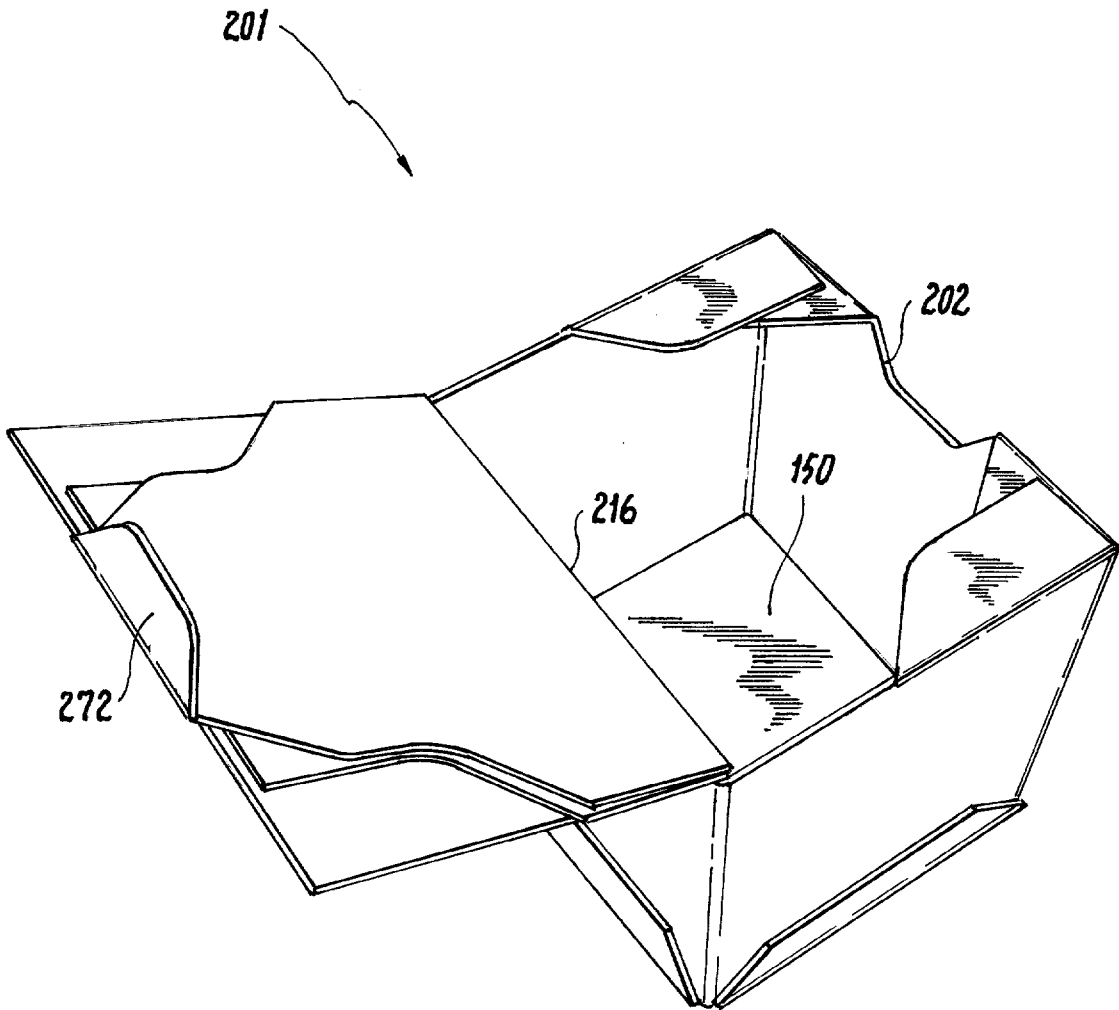
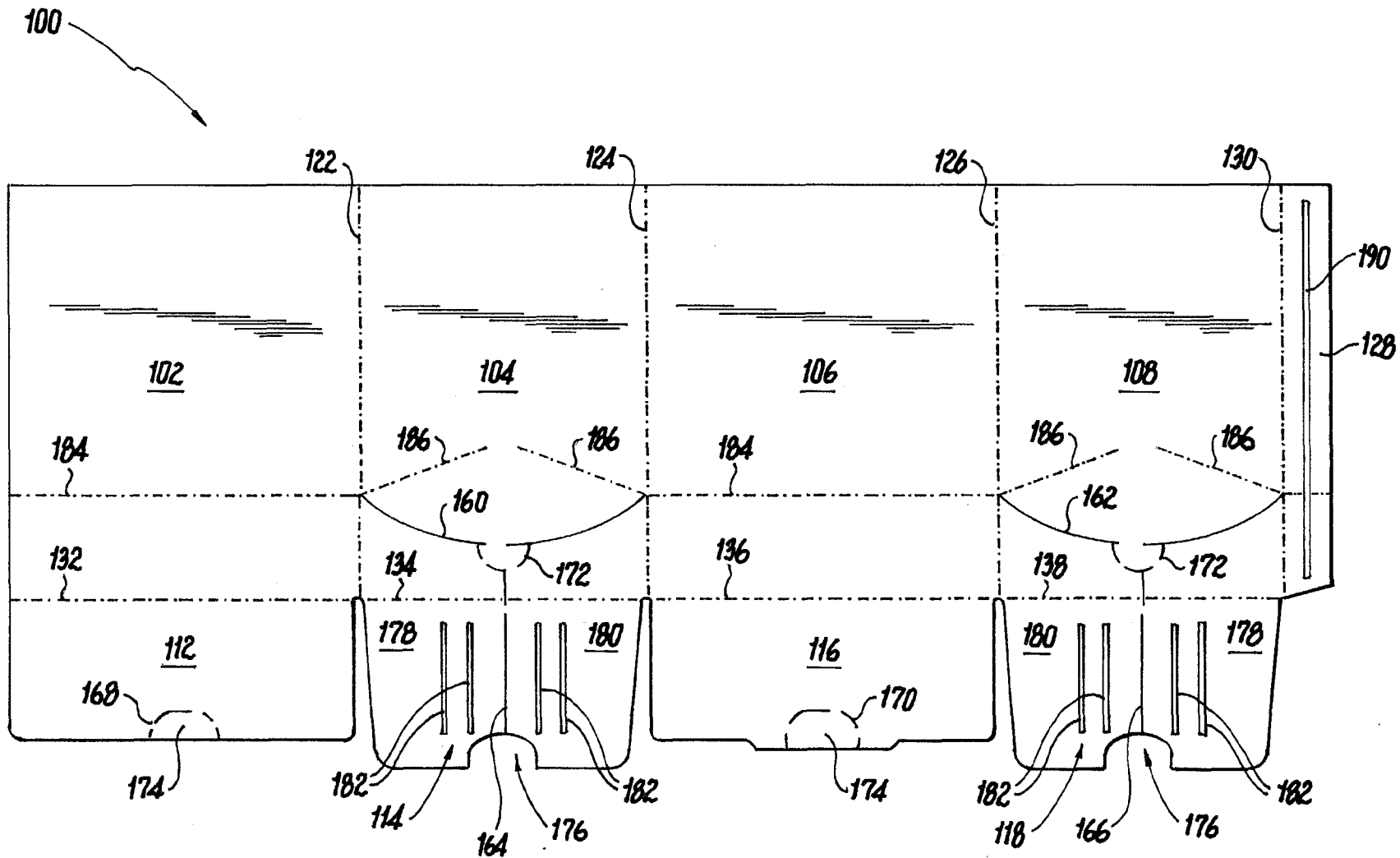

Fig. 6



**Fig. 7**



**Fig. 1**