

(No Model.)

2 Sheets—Sheet 1.

C. N. DENNETT.
CARRIAGE.

No. 522,976.

Patented July 17, 1894.

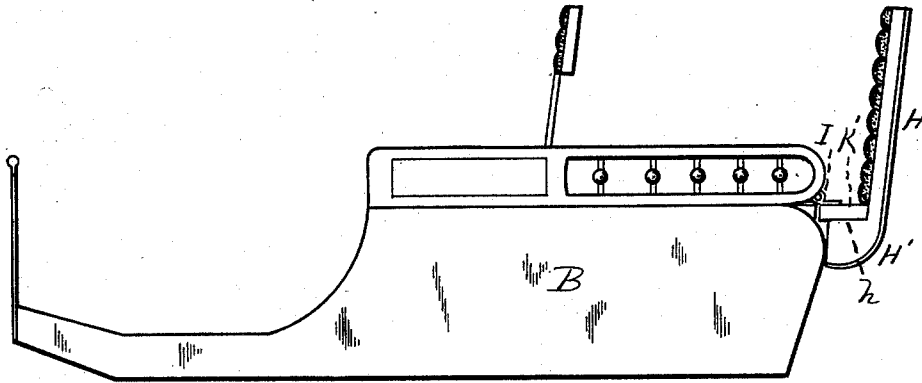

Fig. 1.

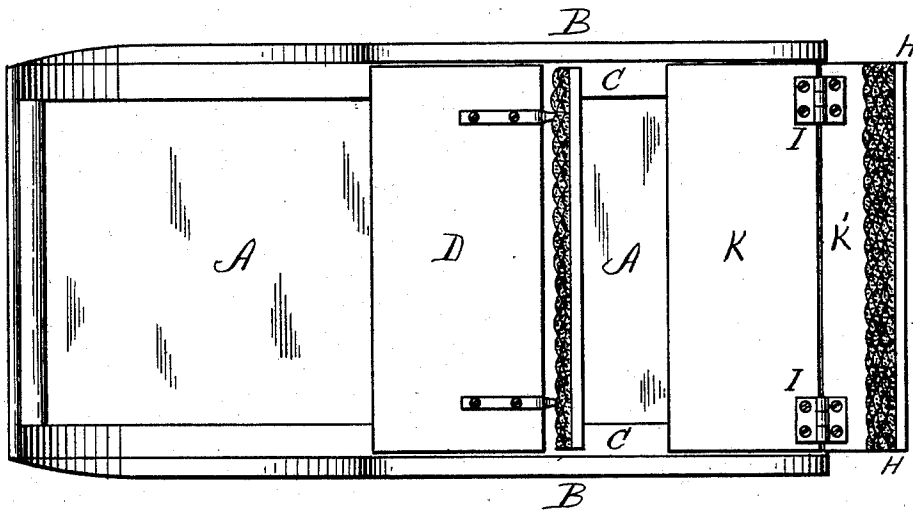

Fig. 2.

WITNESSES

J. M. Hartnett.
E. A. Woodhuff

INVENTOR

Charles N. Dennett.
By his Atty
Henry Williams

C. N. DENNETT.
CARRIAGE.

No. 522,976.

Patented July 17, 1894.

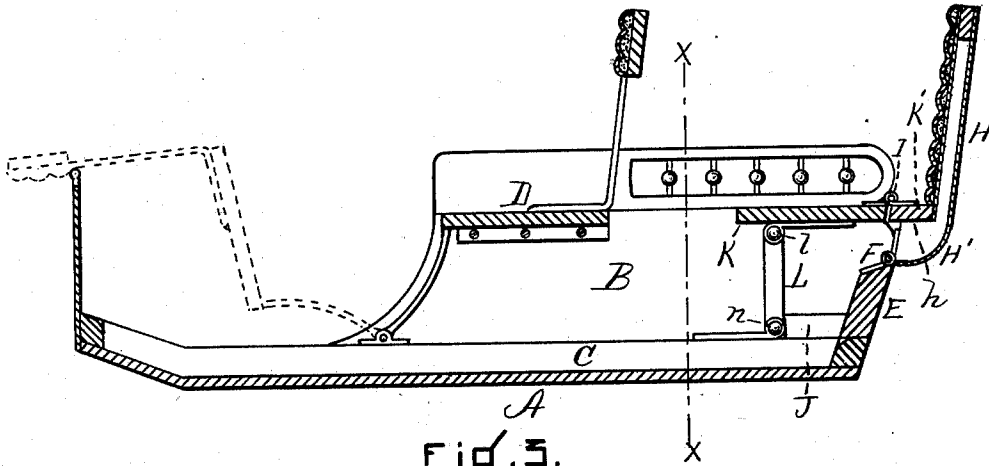

Fig. 3.

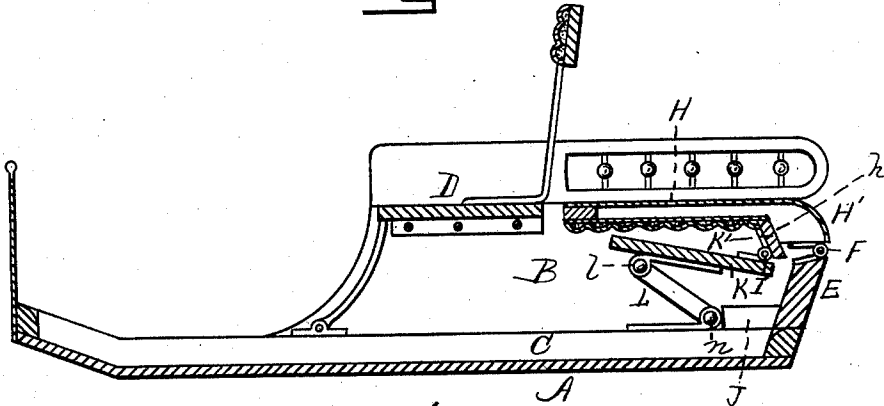

Fig. 4.

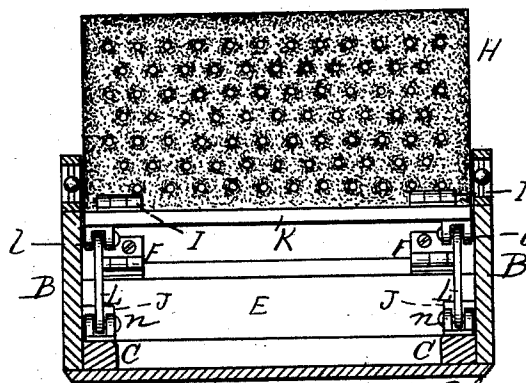

Fig. 5.

WITNESSES

J. M. Hartnett,
E. A. Woodbury

INVENTOR

Charles N. Dennett
By his Atty
Henry Williams

UNITED STATES PATENT OFFICE.

CHARLES N. DENNETT, OF AMESBURY, MASSACHUSETTS.

CARRIAGE.

SPECIFICATION forming part of Letters Patent No. 522,976, dated July 17, 1894.

Application filed April 3, 1894. Serial No. 506,154. (No model.)

To all whom it may concern:

Be it known that I, CHARLES N. DENNETT, a citizen of the United States, residing at Amesbury, in the county of Essex and State of Massachusetts, have invented a new and useful Improvement in Carriages, of which the following is a specification.

This invention relates to that class of carriages in which a seat and seat-back are so arranged that when the seat is not in use it is lowered into the carriage-body by moving the seat-back or lazy-back from its normal vertical position down into a horizontal position in which it serves as a deck or deck-panel.

The nature of the invention is fully described below, and illustrated in the accompanying drawings, in which—

Figure 1 is a side elevation of my carriage with the rear seat raised into position for use. Fig. 2 is a plan view of the same. Fig. 3 is a longitudinal vertical section of the same. Fig. 4 is a similar section with the rear seat lowered into the carriage-body, and the lazy-back in position for use as a deck-panel. Fig. 5 is a cross vertical section on line x , Fig. 3.

Similar letters of reference indicate corresponding parts.

A represents the floor, B the sides, and C the sills.

D represents the front seat, which may be constructed in any desired manner.

E is an immovable back rigidly attached at its ends to the sides B. The upper edge of this back is somewhat lower than the upper edge of the sides, and hinged at F to said upper edge of the back is the deck panel, which constitutes also the lazy-back for the rear seat. This deck-panel H curves gracefully inward at H' near its lower edge, making practically a bend of ninety degrees on its inner side so as to produce the ledge or surface h , while its outer surface at the bend H' is practically an arc of a circle.

The rear side is divided transversely with the carriage-body, and consists of the main front portion K, and the narrower rear portion K' hinged to the part K at I. The portion K' is secured rigidly to the deck-panel H at substantially right angles therewith, its ends resting on the seats produced by the ledge or surface h . The front portion K is

pivotaly secured at l to the upper ends of links or rods L whose lower ends are pivotaly secured at n to the sills C.

When the rear seat is in position for use, the rods L are substantially vertical and serve as supports for the seat, being prevented from swinging to the rear by the stop-blocks J on the sills C, against which they rest, as shown in Figs. 3 and 5. The seat is lowered by grasping the lazy-back H and lowering it into the position shown in Fig. 4, where the back serves as a deck, and the portion K of the seat drops into the body, being accommodated by the forward swinging of the rods L, while the portion K' of the seat folds up, all as shown in Fig. 4.

In addition to the readiness with which my carriage may be converted from a single into a double one, and vice versa, other advantages are possessed by the invention, among which is the additional room given by the rear seat as it is raised, such additional room resulting from the rearward movement of the part K of the seat as it is lifted, until the part K', when brought into line with the part K, extends beyond the rear surface of the end board E, giving plenty of room between the seats. The advantage of a rigid or solid back E instead of a hinged tail-gate is obvious, while the construction gives opportunity for the graceful curvature at H'.

Having thus fully described my invention, what I claim, and desire to secure by Letters Patent, is—

1. In a carriage, a seat consisting of the two portions K and K' of the seat proper divided transversely with the carriage body and hinged together, a rigid back E to the carriage body, and a seat-back convertible into a deck secured to the rearward portion K' of the seat, substantially as set forth.

2. In a carriage, in combination, the rear seat divided transversely with the carriage body and with its two portions hinged together, the rearward portion extending when in use as a seat beyond the rear end of the carriage body, and the seat-back and deck H secured to said rearward portion and with its lower end H' extending inward toward the back under the said rearward portion, substantially as described.

3. In a carriage, a seat divided transversely with the carriage-body and with its two parts pivotally connected, and a seat-back and deck hinged to the carriage-body and rigidly connected with the rearward section of the two-part seat, substantially as set forth.

5
10
15
4. In a carriage, a seat in two parts one of which is connected with the carriage-body by rods or links and is adapted to be raised and lowered in said body and the other of which is pivotally secured to the first part, and a seat-back and deck rigidly secured to the second part and pivotally secured to the carriage-body, whereby the movement of the seat-back lowers one part of the seat into the body, and

folds the other part up and forward, substantially as described.

5. In a carriage provided with a rigid back, the deck H curved inward at H', provided with the ledge h and hinged to the back E, the part K' of the seat rigidly secured to the deck by means of said ledge, and the part K of the seat pivotally secured to the part K' and pivotally connected with the carriage-body, substantially as set forth.

CHARLES N. DENNETT.

Witnesses:

SAMUEL W. NICHOLSON,
G. P. DENNETT.