

(12) INTERNATIONAL APPLICATION PUBLISHED UNDER THE PATENT COOPERATION TREATY (PCT)

(19) World Intellectual Property Organization
International Bureau



(43) International Publication Date
14 February 2002 (14.02.2002)

PCT

(10) International Publication Number
WO 02/12856 A1

(51) International Patent Classification⁷: G01N 1/10, B01L 3/00, 3/02, 11/00, B01D 57/02, 59/42, C02F 1/40, 11/00

(21) International Application Number: PCT/US01/24101

(22) International Filing Date: 31 July 2001 (31.07.2001)

(25) Filing Language: English

(26) Publication Language: English

(30) Priority Data:
60/223,072 4 August 2000 (04.08.2000) US

(71) Applicant (for all designated States except US):
CALIPER TECHNOLOGIES CORP. [US/US]; 605 Fairchild Drive, Mountain View, CA 94043 (US).

(72) Inventors; and

(75) Inventors/Applicants (for US only): **PARCE, J., Wallace** [US/US]; 754 Los Robles Avenue, Palo Alto, CA 94306 (US). **YAO, Yung-mae, M.** [US/US]; 246 San Clemente Drive, Menlo Park, CA 94025 (US). **MORRISSEY, Donald, J., Jr.** [US/US]; 3130 Oak Knoll Drive, Redwood City, CA 94062 (US).

(74) Agents: **QUINE, Jonathan, Alan** et al.; The Law Offices of Jonathan Alan Quine, P.O. Box 458, Alameda, CA 94501 (US).

(81) Designated States (national): AE, AG, AL, AM, AT, AU, AZ, BA, BB, BG, BR, BY, BZ, CA, CH, CN, CO, CR, CU, CZ, DE, DK, DM, DZ, EC, EE, ES, FI, GB, GD, GE, GH, GM, HR, HU, ID, IL, IN, IS, JP, KE, KG, KP, KR, KZ, LC, LK, LR, LS, LT, LU, LV, MA, MD, MG, MK, MN, MW, MX, MZ, NO, NZ, PL, PT, RO, RU, SD, SE, SG, SI, SK, SL, TJ, TM, TR, TT, TZ, UA, UG, US, UZ, VN, YU, ZA, ZW.

(84) Designated States (regional): ARIPO patent (GH, GM, KE, LS, MW, MZ, SD, SL, SZ, TZ, UG, ZW), Eurasian patent (AM, AZ, BY, KG, KZ, MD, RU, TJ, TM), European patent (AT, BE, CH, CY, DE, DK, ES, FI, FR, GB, GR, IE, IT, LU, MC, NL, PT, SE, TR), OAPI patent (BF, BJ, CF, CG, CI, CM, GA, GN, GQ, GW, ML, MR, NE, SN, TD, TG).

Published:

- with international search report
- before the expiration of the time limit for amending the claims and to be republished in the event of receipt of amendments

For two-letter codes and other abbreviations, refer to the "Guidance Notes on Codes and Abbreviations" appearing at the beginning of each regular issue of the PCT Gazette.

(54) Title: CONTROL OF OPERATION CONDITIONS WITHIN FLUIDIC SYSTEMS

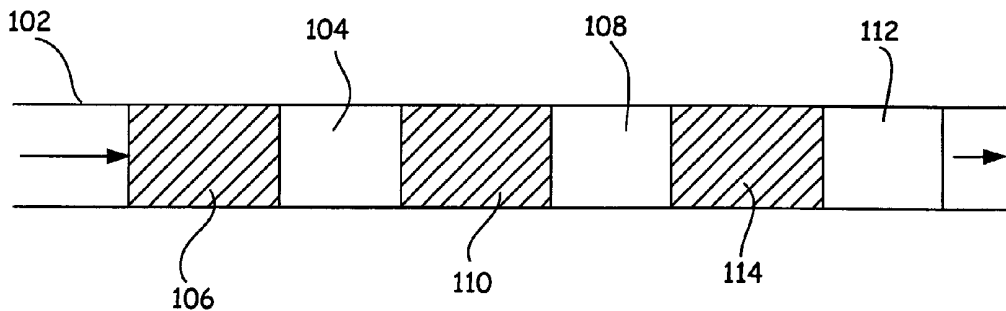

(57) Abstract: Methods of controlling environmental conditions within a fluidic system, where such environmental conditions can affect the operation of the system in its desired function, and fluidic channels segments (102), devices and systems that are used in practicing these methods. Such environmental conditions are generally directed to the fluids (104, 108 and 112) themselves, the movement of such fluids through these systems, and the interaction of these fluids with other components of the system, e.g., other fluids or solid components of the system.



WO 02/12856 A1

CONTROL OF OPERATION CONDITIONS WITHIN FLUIDIC SYSTEMS

5

CROSS-REFERENCE TO RELATED APPLICATION

This application claims priority to Provisional Patent Application No. 60/223,072, filed August 4, 2000, which is incorporated herein by reference in its entirety for all purposes.

10

BACKGROUND OF THE INVENTION

Microfluidic systems have advanced to the point where they are beginning to supplant conventional technologies in biological, chemical and biochemical analyses. For example, routine separation based analyses, e.g., nucleic acid separations, protein sizing separations, and the like are now routinely performed in microfluidic systems, e.g., the Agilent 2100 Bioanalyzer and Caliper LabChip® systems. Similarly, high throughput analytical operations, e.g., pharmaceutical screening, high throughput genetic analysis, and the like, are also being transitioned from multi-well formats into microfluidic formats, such as the Caliper HTS sipper chip systems. These microfluidic systems have allowed for increases in throughput while requiring substantially smaller volumes of reagents, smaller equipment footprint, and having more reproducible, automatable, integratable operations.

15

20

As with any advancing technology however, the miniaturization of analytical chemistries introduces a number of additional considerations. For example, in conventional scale chemical or biochemical analyses, problems associated with interaction between reagents and reaction vessels are kept to a minimum by virtue of the overwhelming volume of reagents used. Similarly, the nature of the reaction vessels used in conventional technologies, while illustrating the advantages of microfluidic systems, also obviate some of the potential problems of microfluidic systems. For example, because these reaction vessels are typically configured as discrete wells or test tubes, there is little or no issue of interaction between discrete reactions that are being analyzed. Similarly, the open-top nature of these vessels allows the evolution of other interfering components, which is not reasonably practicable in sealed microfluidic channels.

25

30

In enclosed microfluidic systems, however, the channel surface to volume ratio is substantially increased over conventional technologies, increasing the effects that those surfaces have on the contents of those channels. Further, because of their enclosed nature, one cannot readily access and control the reactions as they progress through the system. In addition, the sealed nature of these systems can result in the accumulation of evolved gasses from the fluid reagents of a system, where such gases would dissipate into the atmosphere in conventional assay formats.

A number of stop-gap measures have been employed in attempts to address some of these potential problems of microfluidic systems. For example, U.S. Patent No. 5,880,071 describes methods of reducing effects of electrokinetic biasing of reagents within electrically driven microfluidic channel systems. Similarly, U.S. Patent No. 6,043,080 to Lipshutz et al., describes the use of gas venting membranes within a miniature chamber, to permit degassing of fluids within a miniature fluidic environment.

SUMMARY OF THE INVENTION

The present invention is generally directed to methods of controlling environmental conditions within a fluidic system, where such environmental conditions can affect the operation of the system in its desired function, and fluidic channels, devices and systems that are used in practicing these methods. Such environmental conditions are generally directed to the fluids themselves, the movement of such fluids through these systems, and the interaction of these fluids with other components of the system, e.g., other fluids or solid components of the system.

In a first aspect, the present invention is directed to a method of moving a volume of a reaction mixture. The method comprises flowing a volume of a first fluid through a first channel segment, where the first fluid region comprises an environmental control reagent. A first volume of a second fluid is flowed into the first channel segment immediately before or after the step of flowing the volume of the first fluid through the first channel segment.

In a related aspect, the invention provides microscale channels that comprise a first fluid region disposed therein, the first fluid region comprising at least one environmental or operation control reagent. A second fluid region is also typically disposed therein, where the second fluid region comprises at least a first reactant.

BRIEF DESCRIPTION OF THE FIGURES

Figure 1 is a schematic illustration of serial fluid plugs in a fluidic channel, in accordance with certain aspects of the invention.

Figure 2 is a schematic illustration of an exemplary microfluidic device structure.

5 Figure 3 is a schematic representation of a microfluidic assay device and reagent source used in conjunction with high-throughput applications of the present invention.

DETAILED DESCRIPTION OF THE INVENTION

10 I. General

The present invention generally provides methods for optimizing the operation of microscale channel based systems through the use of environmental or operation control reagents within the fluids that are being transported through the capillary channels. In optionally preferred aspects of the invention, the environmental or operation control reagents
15 are transported in fluid regions that are different from fluid regions that contain the reagents of interest for a given analysis, although such reagents may optionally be disposed within the fluid regions that contain the reagents of interest.

As used herein, the phrase "environmental control reagent" or "operation control reagent" refers to a reagent that typically is not involved directly in the reaction of
20 interest, but instead modifies, controls or provides an indication of the state of the environment within a microscale channel in which a reaction of interest is taking place, so as to control that environment or provide the user with information as to the state of that environment such that external controls may be applied. Some specific and preferred examples of environmental controls include modifying the surface characteristics of the
25 microscale channel, adjusting the viscosity and/or the channel flow resistance, and reducing the potential for gas evolution within the channel. Operation control reagents that are used as indicators or diagnostic reagents typically include, e.g., pH indicators, redox indicators, conductivity indicators, and any of a variety of dyes or labels that indicate the presence or absence of particular species, e.g., proteins, nucleic acids, etc. Because the environmental
30 control reagents are flowed through the microscale channels, either as a constant stream, or in periodic pulses, they continually modify and control the environment within those channels or provide constant indicators as to the state of that environment. This is a particularly useful function where one or more environmental conditions within a microscale channel can change over time or deteriorate with respect to the performance of the reaction of interest.

The methods, devices and systems described herein are particularly useful in performing serially oriented microfluidic analyses, e.g., where analytes are separately and serially introduced into a microscale channel. The serial processing is also multiplexed using multiple separate channels, e.g., where a large number of different analytes are subjected to analysis by serially introducing each into a separate one of multiple parallel channels. In such serially processed analyses, it is often desirable, although not always necessary, to space serially introduced analytes from each other. This is primarily to provide an ease of identification of the different analyte regions within a channel, as well as preventing intermixing of analytes and its potential deleterious effects on the analysis being carried out. These spacer fluid regions are ideal vehicles for the environmental control reagents described herein. In particular, conditions for a given analytical reaction can be optimized without having to account for the presence of the environmental control reagent within the reaction fluid region. Alternatively, a wide variety of different analytes can be tested without having to mix them with these environmental control reagents.

Figure 1 is a schematic illustration of a serial process analysis that includes multiple reaction fluid regions interspersed with spacer fluid regions that include environmental control reagents. Specifically, reaction fluid regions 104, 108 and 112 are flowed through a microscale channel segment 102. Spacer fluid regions 106, 110 and 114, which include the environmental control reagents, are interspersed between the reaction fluid regions. The spacer fluid regions 106, 110 and 114 include the environmental control reagents as described herein. Although the reaction fluid regions optionally include the environmental control reagents, in preferred aspects the environmental control reagents are primarily contained within the spacer fluid regions. This allows the use of a single source of environmental control reagents, e.g., in a spacer fluid reservoir, rather than requiring mixing of each of the different reaction fluids with those reagents. Additionally, to the extent environmental control reagents might have any effect on the reactions that are being carried out in the reaction fluid regions, they are kept substantially separated. Further, as each spacer fluid region passes through the microscale channel segment, it performs the particular function or functions for which the reagent is intended. In this manner, the spacer plugs perform somewhat of a "housekeeping" function in the microfluidic channel systems.

In certain preferred aspects, the environmental control reagent is flowed through the channel segment immediately following each region of reaction fluid, e.g., such that the fluid region containing the environmental control reagent(s) are interspersed among reaction regions. In certain aspects, the environmental control reagent region is adjacent to

and abutting the reaction fluid region, to optimize the environmental control function that those reagents perform. However, in those instances where environmental control functions are not necessary on as routine a basis, the period between environmental control reagent additions can be increased, e.g., after 2, 5, 10 or even 20 or more reaction fluid regions, and their optionally associated spacer fluid regions, have passed through the particular channel segment. Conversely, in some cases, an environmental control reagent may be transported through a channel only once or a few times for the lifetime use of a given channel structure, and may increase the useful lifetime of a channel network.

10 II. Surface Modifying Reagents

As noted above, one exemplary environmental control reagent type is a channel surface modifying reagent. In microscale fluidic systems, the nature of the surface of the microscale channel through which materials are being transported can have a significant effect on the operations that are being performed. For example, surfaces can have properties, e.g., surface charges, hydrophobicity, etc., which promotes the sticking of proteins, cells or other reaction materials to those surfaces. This accumulation of material can subsequently interfere with material flowing or other aspects of a reaction of interest. Similarly, in electrically driven microscale channel systems, the existence of charged functional groups on the channel surface can give rise to electrokinetic movement of fluids within channels, where such movement may be more or less desired.

Accordingly, in many microscale fluidic systems it is desirable to treat the surfaces of the channels to mask unfavorable characteristics or provide or accentuate favorable characteristics. Previously, such surface treatments have focused upon pretreating the channel surfaces through coating processes that involved complex chemical treatments to covalently attach chemical modifying agents to those channel surfaces. In certain applications, e.g., where a channel is used a single time, dynamic coating materials have been described, where a solution of the surface modifying agent is disposed within the channel in order to perform the analysis of interest. While these dynamic coatings are useful in a variety of applications, e.g., where the entire channel segment where the analysis is being performed is filled with the dynamic coating material, their non-permanent nature can be a significant drawback to their use in a number of other applications, e.g., applications where such materials can adversely effect the reaction of interest, as the channel surface properties will change over time as the dynamic coatings are washed from the channel surfaces.

It is these latter situations that are particularly advantageously addressed by the methods of the present invention. Specifically, in applications where one is introducing reaction fluid regions into a microscale channel, surface modifying reagents can be introduced into the channel in a separate fluid region that is flowed through the channel before and/or after the reaction fluid region. This can be repeated each time a new reaction fluid region is introduced into the microscale channel segment or at pre-selected intervals, e.g., regularly spaced intervals. As these spacer fluid regions or plugs flow through the channel, they continually coat or re-coat the surface of the channels for a following reaction fluid region.

A wide variety of different materials are useful as surface modification reagents in accordance with the present invention. For example, as noted above, dynamic coatings that are typically comprised of surface adsorbing polymer solutions are used as the surface modifying reagent. Examples of such polymer solutions include linear, e.g., non-crosslinked cellulose polymers, agarose polymers, acrylic polymers, e.g., polyacrylamides, and the like. Particularly preferred polymers include linear polyacrylamide polymers, and more particularly linear polydimethylacrylamide polymers (PDMA) and copolymers of these, e.g., PDMA co-acrylic acid polymers as described in U.S. Patent No. 5,948,227, which is incorporated herein by reference in its entirety for all purposes, monovalent or bivalent compounds that interact with the surface and present different environments to the fluids within the microchannel, e.g., charged groups, hydrophobic moieties, affinity binding moieties, or the like, for use in chromatographic analyses, and the like. A variety of these latter reagents have been described in detail in the art, and could be readily employed in the present invention.

In accordance with this aspect of the invention and with reference to Figure 1, above, the surface modifying reagent is provided in a first fluid region that is transported through a particular microscale channel, whereupon the reagent within the first fluid region modifies the surface of the channel. A second fluid region is preferably introduced into the channel following the first fluid region. As the channel surfaces have been previously modified, the influence of those channel surfaces on the reaction is controlled as desired, e.g., minimized, reduced, increased, or otherwise altered for desired effect. In preferred aspects, an additional first fluid region, e.g., containing the surface modifying reagent, is then transported through the channel after the reaction fluid region, to re-coat the channel surfaces. This ensures a consistent level of environmental control among different, serially introduced reaction fluid mixtures.

In a closely related aspect, the environmental control reagents of the invention can be used to counteract build-up of other reagents within a microscale channel by performing cleaning functions within the channel. For example, as noted above, microscale channels, and particularly uncoated microscale channels are very susceptible to deposition and accumulation of material within a flowing system, e.g., as a result of the surface charge or hydrophobicity of the channel surface. Such accumulation can affect the continued operation of a microfluidic system by affecting the concentration of reagents, interfering with detection techniques, etc. Accordingly, in accordance with the present invention, environmental control reagents that are flowed through the channels of the device include "cleaning" agents to remove any accumulated material from channel walls. In its simplest form, such cleaning agents include acids (e.g., HCl), bases (e.g., NaOH), detergents, high salt solutions (NaCl, NH_4SO_4 , and the like), zwitterionic solutions, e.g., amino acid solutions, nondetergent sulfobetaine (NDSB), and others. Acid or base solutions are typically used at concentrations of greater than 1 mM and preferably greater than about 10 mM, and in some cases greater than 50 mM. In such cases, the environmental control reagents may be separated from sample material containing fluids by a strongly buffered spacer fluid region, e.g., to avoid damaging the sample material. Salt concentrations will generally vary depending upon the nature of the cleaning operation to be carried out and may be in excess of 10 mM and often in excess of 20 or even 50 mM. Similarly, in the case of detergents, a variety of detergents are commercially available and may be employed as desired as an environmental control reagent.

III. Viscosity/Flow Resistance Adjusting Reagents

Environmental control, as used in conjunction with the present invention may also include control of the overall or average fluidic characteristics of a microscale channel or channel network. For example, in pressure driven fluidic systems, e.g., systems where fluid flow is controlled by application of pressure differentials across channels, the rate of flow within channels is dictated, at least in part, by the level of flow resistance within a particular channel. Flow resistance of a channel can be manipulated by adjusting the structural characteristics of the channel, e.g., its length, width and or depth. However, such manipulations are typically carried out at the time of manufacturing of the channel system and are not readily altered.

Flow resistance can also be altered by altering the characteristics of the fluid flowing through the channels. In particular, by adjusting the viscosity of fluids flowing

through channels, one can alter the overall flow resistance of those fluids. In accordance with the present invention, certain fluid regions, e.g., spacer fluid regions, can be viscosity adjusted to achieve an overall change in flow resistance through the channel. Implicit in this description is the optional situation where certain fluid regions are not adjusted for viscosity.

5 This can result from an inability to practically adjust viscosity in some of the fluids, due to their numbers, etc., or can be a result of negative interactions between the viscosity adjusting reagents and those other fluids, e.g., reaction components.

A variety of viscosity adjusting reagents may be used in accordance with the present invention, including polymeric reagents, e.g., cellulose, agarose, gelatin,
10 polyacrylamides, i.e., PDMA and co-polymers thereof, PEGs and other polyalcohols, Ficoll, hydrogels, and the like.

IV. Reagents for Controlling Gas Evolution

Another environmental characteristic that can pose potential problems in
15 microfluidic channel systems, and for which the present invention is particularly suited is the variation in dissolved gases within fluids flowing through the channels of the system. In particular, where fluids in microfluidic systems have the potential to evolve dissolved gases, such gases can create substantial problems in microscale channels, including blocking or otherwise restricting flows in channel networks, which can substantially disrupt the efficient
20 operation of those systems. In analytical reactions, the potential for gas evolution is increased where, as in many bioanalytical operations, temperatures are maintained at elevated levels to optimize assay conditions. Similarly, many microfluidic operations involve the use of pressure gradients to manipulate fluids within microscale channel networks. Substantial changes in pressures can lead to outgassing within the channel system. For example, often
25 fluid flow is driven by an applied vacuum, where the pressure drop across the channel network can result in substantial degassing of fluids within the channel networks, where those fluids are sufficiently saturated.

In accordance with the present invention, an environmental control reagent comprises a fluid reagent that is capable of controlling dissolved gas levels within the channel
30 system at levels that do not result in gas evolution within the channels under the conditions of operation. In the simplest aspect, the environmental control reagent in this context is a fluid reagent, e.g., buffer, water, etc., that has a dissolved gas level that is far below the level where gas evolution would be expected in the operation that is being carried out, e.g., at the temperatures and pressures or vacuums involved within the microscale channel systems.

Typically, this gas control fluid also has a dissolved gas level that is sufficiently below that of most, if not all of the other fluids that are used in the particular analytical operation, e.g., the reaction fluids, spacer fluids, etc. such that when all of the fluids are mixed, the resulting solution will not evolve gas under the operating conditions of the particular operation.

5 Because the gas control fluid has such a low level of dissolved gas, it can serve to scavenge excess dissolved gases from the other fluid regions within the channel networks, e.g., the reaction fluid regions, where a degassing operation may not have been reasonably practicable and as a result may have dissolved gas levels that could result in gas evolution within the microscale channel system. In particular, for many operations, e.g., high
10 throughput analytical operations, it is not reasonably practicable to de-gas all of the different sample materials that one is analyzing. Further, in many cases, sample materials are subjected to numerous in-process, but out-of-channel manipulations, e.g., dilutions, mixing, etc. which would effectively negate any attempts at degassing. By maintaining certain fluids within a channel system at dissolved gas levels that are well below saturation, one can
15 balance the effects of higher gas concentrations in other fluids used in the operation. As used herein, the term "saturation" refers to the gas saturation point of a given fluid under the then current conditions within a microscale channel. As a result, the saturation point, or gas solubility, of a particular fluid at one temperature and pressure will be different from the saturation point of the fluid at another temperature and/or pressure.

20 The reduced level of dissolved gas within the gas control reagents, as described herein, is generally dependent upon the particular operation that is to be carried out, rather than being an absolute characteristic. In particular, where desired operation is to be carried out within a microchannel structure at lower temperatures, higher absolute concentrations or levels of dissolved gas can be tolerated without evolution. Conversely,
25 where a particular operation is carried out at higher temperatures, lower dissolved gas concentrations are tolerated. Similarly, where negative pressures are applied to fluids within a channel, e.g., as compared to ambient pressure of the fluids prior to their introduction into the channel system, it is generally required that such fluids have lower dissolved gas concentrations in order to avoid outgassing within the channels. Conversely, positively
30 pressurized channels are generally capable of supporting fluids with higher dissolved gas concentrations.

From the particular conditions of a given operation, one can readily determine the level of acceptable dissolved gas, in order to avoid any problems associated with gas evolution within the channels, e.g., bubble formation. For example, where one knows the

temperature at which the fluid is maintained within the channel system, the amount of dissolved gas in some of the fluid reagents, and the amount of applied vacuum in a given channel, one can determine the acceptable level of dissolved gas within a spacer fluid, as well as the relative amount of that spacer fluid needed, to counter any potential of outgassing
5 within the channel. Specifically, one can provide a sufficient amount of a spacer fluid within a channel, where that spacer fluid has a sufficiently low level of dissolved gas, such that any excessive gas concentrations of any of the remaining fluid reagents is absorbable by the spacer fluids without outgassing under the conditions of the operation.

By way of example, where a microfluidic channel network is operated at -2 psi
10 vacuum to cause fluid flow, while the device and all of the reagents are at room temperature, and where the environmental control reagent makes up 40% of the overall fluid volume within the channels of the device, then the environmental control reagent must be at or below 75% saturation with air at room temperature and 1 atmosphere pressure.

Typically, the gas control reagents are only required to be at a saturation level
15 that is at or below that necessary to prevent outgassing of a given system under that system's operating conditions. In accordance with this principle, the degassing fluid need only have somewhat less. However, in general, this results in the gas control reagents having a dissolved gas concentration that is less than 90% of the saturation concentration for any portion of the operation that is to be carried out within the microscale channel system. In
20 preferred aspects, the gas control reagent has a dissolved gas concentration that is less than 80%, more preferably, less than 60%, more preferably, less than 50%, and often less than 40%, 30% or even 20% of the saturation level of dissolved gas in any portion of the operation being carried out.

Although described above in terms of the use of a degassing reagent or fluid
25 within a microfluidic channel system, it is also an aspect of the invention to operate microfluidic systems under conditions that prevent such outgassing, e.g., using any or all fluids within the channel network to prevent outgassing. In particular, as noted above, the conditions which prevent outgassing will generally depend upon other conditions of the system, e.g., the applied pressure, the gas saturation level of the fluids within the channels
30 and the gas saturation level of the fluids prior to entering the channel. Gas saturation is highly temperature dependent, e.g., colder fluids can dissolve larger amounts of oxygen than warmer fluids. Similarly, fluids maintained at a lower pressure will evolve more gas than fluids kept at higher pressure. Accordingly, by adjusting one or more of the temperatures of the fluids before and after entering a microfluidic channel network, and/or the pressure or

vacuum applied to a system, one can ensure that the system operates under non-out-gassing conditions.

In particularly preferred aspects, the applied pressure is determined by the desired flow rate through the system, e.g., resulting from desired throughput or reaction
5 times. Accordingly, prevention of outgassing is typically a matter of adjusting one or more of the temperatures of the fluids prior to entering the channels and after entering the device. By way of example, a fluid that is maintained at a first temperature, but which is heated upon entering the channel network poses a substantial risk of bubble generation within the channels. This is particularly true where the flow of fluids in the channels is driven by
10 vacuum. Accordingly, to remedy this issue, prior to drawing fluids into the channel network, one can (1) maintain all of the fluids at a temperature that is at or above the temperature of the channel network; (2) elevate the temperature of some portion of fluids (e.g., environmental control/degassing fluids) above the temperature of the channel network; or (3) cool the channel network to a temperature below that of the outside fluids. Finally, one could
15 also perform any of these adjustments in conjunction with changes in the level of applied pressure to the channel system. As channel temperatures are often optimized for the particular analysis, it is generally preferable that most of the temperature adjustments be made to the fluids prior to their entering the channel networks. This is typically a simple matter of providing a heating element to the sources of these fluids, e.g., multiwell plates, reagent troughs, or the like. Again, as described above, relative temperatures of fluids inside
20 and outside the channel networks are dependent upon the nature of the overall conditions. Typically, however, fluids are maintained at least 1 °C over the temperature of the microscale channel network (also referred to as the chip temperature), and preferably, more than 5°C. This is particularly the case where only a portion of the fluids to be introduced into the chip are provided outside the chip at elevated temperatures. In some cases higher temperature differentials are desirable and may be 10, 20, 30°C or more, e.g., the temperature of the fluids prior to entering the channel network is 10, 20 or 30°C higher than the chip temperature. Alternatively or additionally, one can adjust the pressures to which the fluids are subjected so as to prevent bubble formation within a microchannel. For example, in one aspect, one can
30 subject fluids to a low pressure environment, e.g., below ambient, by applying a vacuum to the fluids to degas those fluids prior to introducing them into the channels of the system. Alternatively, or additionally, one can maintain the pressures within the channels at levels

that prevent such degassing, e.g., above ambient or the pressure at which the fluids were kept prior to introduction into the channels.

In preferred aspects, because fluids are often flowed through microchannels under an applied vacuum, the latter alternative is not optimally applicable in all situations.

5 As such, where pressure adjustments are used to prevent degassing within the microchannel, it is typically applied as a preloading step, e.g., fluids are subjected to vacuum prior to loading into a channel.

10 In particularly preferred aspects, the fluids to be introduced are subjected to either one or both of an elevated temperature or reduced pressure environment immediately prior to introducing those fluids into the channels, to prevent re-equilibration of the fluids at atmospheric temperatures, and so as not to necessitate complex sealed bottle systems. As used herein, "immediately prior to introduction" means 5 minutes or less before fluid introduction, preferably 1 minute or less, and often 30 seconds or less. In certain systems, a trough of fluids is continuously recirculated and subjected to elevated temperatures.

15 Although the preferred gas control reagents comprise fluids having sufficiently low dissolved gas concentrations, e.g., buffers, water etc., it will be appreciated that gas absorbing additives may also be used in conjunction with this aspect of the present invention, in order to reduce the potential for outgassing during a given operation. For example, in certain embodiments, it may be useful to employ liquids that have very high oxygen saturation levels, i.e., fluorocarbons and perfluorocarbons.

V. Other Operational Control Reagents

In addition to the environmental control reagents described above, intermediate fluid slugs in microfluidic channels can be put to a variety of other useful functions in microfluidics based analyses. For example, spacer fluid slugs optionally incorporate signaling components, e.g., dyes, labels, etc., so as to provide an indicator component of the spacer slugs versus the sample slugs. Such indicators may be varied in terms of the nature of the label, e.g., in the case of fluorescent labels, via it's wavelength of excitation, emission, intensity or the like, to provide the ability to distinguish between spacer slugs at different points in an operation. By way of example, a spacer slug early in an assay run may have a first signaling component, e.g., fluorescing at a first wavelength or combination of wavelengths, whereas later spacer slugs fluoresce at a different wavelength or combination of wavelengths. Depending upon the nature of the spacer slug's label, one can determine where the system is in a given operation, in order to identify intermediate steps in

an operation, or match analysis data with exogenously introduced reagent slugs, e.g., allowing identification of the particular reagent slug. Such different labels can be provided by sampling spacer fluids from different sources at different time points in an operation, or by constantly adjusting the signal component make-up of a single source of spacer fluid. For example, a trough of spacer fluid may be slowly, but constantly supplemented with a new labeled signaling component, so as to produce an increasing level of signal in later sampled spacer fluid slugs.

Spacer slugs containing signaling components may also be used as calibrators for detection systems used in conjunction with the devices and methods described herein. In particular, a known concentration of signaling component can be used to set detection system so as to optimally detect assay results.

In addition to the foregoing, signaling components of spacer slugs can be used as indicators or diagnostics of other environmental conditions within a microscale channel system. For example, temperature sensitive signaling components may be used to monitor temperature within such systems over the course of an assay run, while pH sensitive signaling components may be used to indicate intrachannel pH or changes therein. Additionally, ion specific indicators, or generic conductivity indicators may be used. A variety of temperature sensitive signaling components may be used in conjunction with this aspect of the invention, including molecular beacons, self hybridizing nucleic acid sequences that become fluorescent when heated above their melting temperatures. Similarly, pH indicating labels or dyes are widely available from commercial sources, including, e.g., Molecular Probes, Inc. (Eugene, OR). Dyes or labels can also be provided to indicate the level of macromolecular buildup within channels, which buildup might affect the functions of the channels, or their usefulness in a given analysis. Such dyes include protein indicators, nucleic acid indicators, and the like.

VI. Microscale Channels and Systems

As noted repeatedly above, the present invention is most useful in the context of analytical operations that are carried out within a sealed microscale channel environment. In its simplest form, such an environment includes a simple channel, e.g., a capillary, tube or other enclosed conduit through which fluid materials are flowed. However, in preferred aspects, the operations in question are carried out within more complex networks of microscale fluid channels, e.g., in microfluidic devices. Typically, such devices include at least two different microscale channels disposed within the same single body structure.

Often, the at least two microchannels will be in fluid communication with each other, e.g., at a channel junction, to form an integrated channel network. In general, microfluidic devices incorporating complex channel geometries have been previously described in, e.g., U.S. Patent Nos. 5,869,004, 5,942,443, 5,976,336, 6,042,709 and 6,068,752, each of which is
5 incorporated herein by reference in its entirety for all purposes. As used herein, the term microchannel typically refers to a channel conduit that has at least one cross-sectional dimension between 0.1 and 500 μ m. Preferably, at least one cross-sectional dimension of a microchannel is between about 1 and about 100 μ m.

While microfluidic devices may be fabricated as an aggregate of different
10 parts, e.g., capillaries and chambers, pieced together in a desired orientation, in preferred aspects, such devices are fabricated in a monolithic format, integrated in solid substrates. In particular, microscale channels and channel networks are typically fabricated as grooves into a surface of at least one planar substrate layer. The first substrate layer is then overlaid with a second substrate layer, which is bonded to the first, to seal and enclose the grooves as
15 microscale channels. Reservoirs or access ports are optionally provided in one or both of the substrate layers to provide access to the channels from the outside world. Additional substrate layers are optionally added to increase to the complexity of channel networks that may be produced. Similarly, individual channel networks may be duplicated within one or more different body structures, in order to multiplex operations, and gaining the consequent
20 improvements in throughput. Figure 2 provides a schematic illustration of the assembly of a layered microfluidic device. As shown, the device 10 includes a lower planar substrate 12 having a plurality of grooves fabricated into its surface. An upper substrate layer 18 is also provided that includes a plurality of apertures disposed through it. The apertures are positioned so as to be in communication with the grooves when the upper layer is placed
25 upon and bonded to the lower substrate. This bonding also seals the grooves as enclosed channels or conduits. Although illustrated as grooves on the lower substrate and apertures through the upper substrate, it will be appreciated that grooves and apertures may be disposed in either and/or both substrates depending upon the desired nature of the finished microfluidic device.

30 Methods for manufacturing microfluidic devices have been previously described, and include techniques commonly employed in the integrated circuit industries, e.g., photolithography and wet chemical etching, for silica based solid substrates, as well as

other well known microfabrication techniques for other materials, e.g., injection molding and embossing techniques for polymer-based materials (see, e.g., U.S. Patent No. 5,885,470).

Generally, such devices are mounted on an instrument that includes fluid transport systems, as well as detection systems, whereby the instrument interfaces with the microfluidic device to control fluid movement and detect assay results within the channels of the microfluidic device. Such instruments are exemplified by, e.g., the Agilent Technologies 2100 Bioanalyzer and the Caliper Technologies HTS "Sipper" platform, as described at www.calipertech.com and [www. Agilent.com](http://www.Agilent.com), the contents of which are hereby incorporated herein by reference in their entirety for all purposes. Microfluidic devices, methods and systems that include serially introduced fluidic regions, e.g., as described in the preferred embodiments of the invention, are described in substantial detail in U.S. Patent Nos. 5,942,443, and 6,042,709, each of which is incorporated herein by reference in its entirety for all purposes.

The devices and methods of the invention may be employed in conjunction with appropriate instrumentation depending upon the nature of the analysis that is to be performed. For example, for lower throughput operations, microfluidic devices are readily configured for operation on commercially available controller/detector instrument, e.g., an Agilent 2100 Bioanalyzer that is equipped with at least one pressure/vacuum source. Similarly, higher throughput operations are readily configured to operate on sipper systems that are available from Caliper Technologies Corp. Such systems are described in detail at www.agilent.com and www.calipertech.com and in U.S. Patent Nos. 5,955,028, 6,042,709 and 6,071,478, each of which is incorporated herein by reference in its entirety for all purposes, as well as the patents described elsewhere herein, and incorporated herein by reference.

VII. Examples

The degassing functions of the present invention were modeled and applied in a high-throughput screening system that incorporates a microfluidic channel network. A simplified schematic illustration of the microfluidic device and overall system is shown in Figure 3. As shown, the microfluidic device 300 includes a planar body structure 302 that includes a channel network disposed within its interior. The channel network includes a main analysis channel 304 that is coupled at one end to an external capillary element 306, via inlet 308. At the other end, the main channel 304 is fluidly connected to reservoir/port 310. Two side channels 312 and 314 intersect and are in fluid communication with the main channel

304. These channels provide a connection between the main channel 304 and reagent reservoirs 316 and 318, respectively. In the examples described below, sample material is sampled into the main analysis channel through the external capillary 306 by dipping the open end of the capillary into a source of sample material 320 and applying a vacuum at reservoir/port 310. The applied vacuum draws a slug of sample material into the capillary element 306 and moves it into the analysis channel 304. In the system shown, a spacer fluid is introduced after the sample material slug, in order to space the sample material from subsequent sample materials. The spacer buffer is sampled into the system the same way that the sample is drawn in. Specifically, the capillary element is placed into contact with the trough 322 of spacer buffer and a slug of spacer fluid is drawn into the system. Within main channel 304, additional reagents needed for a given analysis are brought into the main channel 304 from the side channels 312 and 314. Movement of reagents into channel 304 from these side channels is driven by the same vacuum used to draw materials in through the capillary element. In the context of the present example, the spacer fluid constituted the degassing fluid.

Degassing parameters were calculated for a system having the attributes described with reference to Figure 3. In particular, a number of physical and temporal parameters of the operation of a microfluidic device are dictated by the particular analysis to be carried out therein. Those parameters were then used to calculate the maximal allowable level of oxygen within the spacer fluid in order for that fluid to function as a degassing reagent. In order to achieve this oxygen level, therefore, a minimum spacer fluid trough temperature was calculated, e.g., to provide spacer fluid at an acceptable oxygen level. By providing the spacer fluid below maximal oxygen levels, substantial reductions in bubble formation and channel blockage have been observed. Exemplary calculations are provided below.

In one exemplary analysis, sample compounds are sipped for 2 seconds, while spacer fluids are sipped for 1 second. Transit time between the sample well 320 and the spacer fluid trough 322 is 1.5 seconds. For the particular example chip/channel configuration, flow into main channel 304 from the side channels is 50% of the total flow, e.g., 25% from each side channel. The temperature of the sample material is assumed to be room temperature or 22°C, while the device temperature is elevated to 28°C. This elevated temperature is generally desirable to accelerate analysis chemistries within the device. Finally, a vacuum of -0.3 psi is applied to reservoir/port 310 to drive fluid flow through the channels of the device. These parameters were then used to calculate the maximal level of

oxygen within the spacer fluid in order to avoid any degassing or bubble formation within the channels of the device, e.g., under the temperature and pressure conditions applied. In carrying out the calculations, two alternate scenarios were assumed. The first case is where a hanging droplet of fluid at the end of the capillary element does not equilibrate with air during the transit time from the sample to the trough. The second case assumes that the droplet becomes fully equilibrated with air during transit. Given that the radius of the water droplet is 0.018 cm and the diffusion constant for oxygen in water is $2 \times 10^{-5} \text{ cm}^2/\text{s}$, giving a diffusion time of 8.1 seconds, the droplet should not equilibrate during a typical transit time, e.g., 1.5 seconds. The calculations are set forth below:

Input Parameters		
Parameter	ID	Value
Sample plate sip time (s)	PST	2
Trough sip time (s)	TST	1
Sipper transit time (s)	STT	1.5
Side channel flow (fraction)	SAF	0.5
Sample plate temperature (°C)	PT	22
Chip temperature (°C)	CT	28
Applied vacuum (psi)	V	0.3

10

Calculated Parameters			
Parameter	ID	Case 1	Case 2
Sample plate flow (%)	FP	29.2	41.7
Trough flow (fraction)	FT	20.8	8.3
[O ₂] in plate	OP	4.17×10^{-3}	4.17×10^{-3}
[O ₂] in side channel reservoirs	OS	3.71×10^{-3}	3.71×10^{-3}
[O ₂] allowable in chip	OAC	3.63×10^{-3}	3.63×10^{-3}
[O ₂] allowable in trough	OAT	2.7×10^{-3}	2.7×10^{-3}
Minimum trough temp.	MTT	50	94
% Saturation in trough	%O2	65	12

The calculations used to calculate these parameters were as follows:

$$FP1 = [(PST + STT) / (PST + TST + 2 * STT)] [1 - SAF]$$

$$FP2 = [(PST + 2 * STT) / (PST + TST + 2 * STT)] [1 - SAF]$$

$$FT1 = [(TST + STT) / (PST + TST + 2 * STT)] [1 - SAF]$$

15

$$FT2=[TST/(PST+TST+2*STT)][1-SAF]$$

[O₂] in grams of gas/100 grams of water at atmospheric pressure and temperature T is
 [O₂]=13417e-5*(T)-1.301e-8*(T-58.04)^3+4.310e-3

5

$$OAC=OS*((14.7-V)/14.7)$$

OAT=(OAC-OP*FP(n)-S*SAF)/FT(n) where (n) is 1 or 2 depending on the case.

10

$$MTT=(100-6.628e4*(O_2) + 1.5e7(O_2)^2-1.084e9(O_2)^3)/1-5.703e2(O_2)+1.443e5(O_2)^2-2.563e7(O_2)^3+3.298e9(O_2))$$

$$\%O_2=(OAT/OP)*100$$

As noted above, when the trough is maintained above the calculated minimum
 15 trough temperature for a given operation, channel plugs resulting from outgassing within
 channels is substantially reduced.

All publications and patent applications are herein incorporated by reference
 to the same extent as if each individual publication or patent application was specifically and
 individually indicated to be incorporated by reference. Although the present invention has
 20 been described in some detail by way of illustration and example for purposes of clarity and
 understanding, it will be apparent that certain changes and modifications may be practiced
 within the scope of the appended claims.

What is claimed is:

- 1 1. A method of moving a volume of a reaction mixture, comprising:
2 introducing a first volume of a first fluid into a first channel segment, the first
3 fluid comprising an environmental control reagent; and
4 flowing a first volume of a second fluid into the first channel segment, the
5 second fluid comprising the reaction mixture.

- 1 2. The method of claim 1, wherein the first volume of the first fluid is
2 introduced into the first channel segment after the first volume of the second fluid is flowed
3 through the first channel segment.

- 1 3. The method of claim 2, further comprising flowing a volume of a first
2 volume of a third fluid through the first channel segment after the first fluid is flowed through
3 the first channel segment.

- 1 4. The method of claim 1, wherein the second fluid comprises a first test
2 compound.

- 1 5. The method of claim 4, wherein the second fluid comprises at least a
2 first component of a biochemical system.

- 1 6. The method of claim 1, wherein the environmental reagent comprises a
2 degassing fluid.

- 1 7. The method of claim 6, wherein the degassing fluid comprises a fluid
2 that is not gas saturated.

- 1 8. The method of claim 6, wherein the degassing fluid comprises a fluid
2 having less than 90% gas saturation.

- 1 9. The method of claim 6, wherein the degassing fluid comprises a fluid
2 having less than 80% gas saturation.

- 1 10. The method of claim 6, wherein the degassing fluid comprises a fluid
2 having less than 60% gas saturation.
- 1 11. The method of claim 6, wherein the degassing fluid comprises a fluid
2 having less than 50% gas saturation.
- 1 12. The method of claim 6, further comprising degassing the first fluid
2 immediately prior to the step of flowing the first volume of first fluid through the first
3 channel segment.
- 1 13. The method of claim 12, wherein the degassing step comprises heating
2 the first fluid.
- 1 14. The method of claim 12, wherein the degassing step comprises
2 subjecting the first fluid to a negative pressure.
- 1 15. The method of claim 1, wherein the first fluid comprises a channel
2 surface modifying reagent.
- 1 16. The method of claim 15, wherein the surface modifying reagent
2 comprises a surface adsorbing polymer.
- 1 17. The method of claim 16, wherein the surface adsorbing polymer
2 comprises a silica adsorbing polymer.
- 1 18. The method of claim 1, wherein the first fluid comprises a viscosity
2 adjusting reagent.
- 1 19. The method of claim 1, wherein the first fluid comprises a complexing
2 reagent.
- 1 20. The method of claim 1, wherein the first fluid comprises a reaction
2 inhibiting reagent, and the second fluid comprises at least a first reactant.

1 21. The method of claim 20, wherein the reaction inhibiting reagent
2 comprises an inhibitor of a reaction involving the at least first reactant.

1 22. The method of claim 21, wherein the first reactant comprises a first
2 enzyme, and the inhibitor inhibits an action of the enzyme.

1 23. The method of claim 21, wherein the first reactant comprises a specific
2 binding pair of reagents, and the inhibitor inhibits binding of a first member of the binding
3 pair to the second member of the binding pair.

1 24. The method of claim 23, wherein the specific binding pair comprises
2 one or more of an antibody/antigen pair, a complementary nucleic acid pair, a nucleic acid
3 binding protein/nucleic acid pair, and a receptor/ligand pair.

1 25. A microscale channel, comprising:
2 a first fluid region disposed therein, the first fluid region comprising at least
3 one environmental control reagent; and
4 a second fluid region disposed therein, the second fluid region comprising at
5 least a first reactant.

1 26. The microscale channel of claim 25, wherein the first and second fluid
2 regions are adjacent to each other within the first channel.

1 27. The microscale channel of claim 25, wherein the second fluid region is
2 bounded on both sides within the channel by the first fluid.

1 28. The microscale channel of claim 25, wherein the second fluid
2 comprises a first test compound.

1 29. The microscale channel of claim 28, wherein the second fluid
2 comprises at least a first component of a biochemical system.

1 30. The microscale channel of claim 25, wherein the environmental
2 reagent comprises a degassing fluid.

1 31. The microscale channel of claim 30, wherein the degassing fluid
2 comprises a fluid that is not gas saturated.

1 32. The microscale channel of claim 30, wherein the degassing fluid
2 comprises a fluid having less than 90% gas saturation.

1 33. The microscale channel of claim 30, wherein the degassing fluid
2 comprises a fluid having less than 80% gas saturation.

1 34. The microscale channel of claim 30, wherein the degassing fluid
2 comprises a fluid having less than 60% gas saturation.

1 35. The microscale channel of claim 30, wherein the degassing fluid
2 comprises a fluid having less than 50% gas saturation.

1 36. The microscale channel of claim 25, wherein the first fluid comprises a
2 channel surface modifying reagent.

1 37. The microscale channel of claim 36, wherein the surface modifying
2 reagent comprises a surface adsorbing polymer.

1 38. The microscale channel of claim 37, wherein the surface adsorbing
2 polymer comprises a silica adsorbing polymer.

1 39. The microscale channel of claim 25, wherein the first fluid comprises a
2 viscosity adjusting reagent.

1 40. The microscale channel of claim 25, wherein the first fluid comprises a
2 complexing reagent.

1 41. The microscale channel of claim 25, wherein the first fluid comprises a
2 reaction inhibiting reagent, and the second fluid comprises at least a first reactant.

1 42. The microscale channel of claim 41, wherein the reaction inhibiting
2 reagent comprises an inhibitor of a reaction involving the at least first reactant.

1 43. The microscale channel of claim 42, wherein the first reactant
2 comprises a first enzyme, and the inhibitor inhibits an action of the enzyme.

1 44. The microscale channel of claim 42, wherein the first reactant
2 comprises a specific binding pair of reagents, and the inhibitor inhibits binding of a first
3 member of the binding pair to the second member of the binding pair.

1 45. The microscale channel of claim 44, wherein the specific binding pair
2 comprises one or more of an antibody/antigen pair, a complementary nucleic acid pair, a
3 nucleic acid binding protein/nucleic acid pair, and a receptor/ligand pair.

1 46. A method of preventing bubble formation in a fluid containing
2 microchannel structure, comprising:
3 providing a first fluid in the first microchannel, the first fluid having a first
4 dissolved gas concentration; and
5 maintaining the first fluid at a first temperature and pressure once the first
6 fluid is introduced into the microchannel, the first temperature and pressure being sufficient
7 to prevent bubble formation within the first fluid having the first dissolved gas concentration.

1 47. The method of claim 46, further comprising providing a second fluid
2 having a second dissolved gas concentration within the first microscale channel, wherein the
3 first temperature and pressure and the first dissolved gas concentration in the first fluid are
4 sufficient to prevent bubble formation within the second fluid having the second dissolved
5 gas concentration under the first temperature and pressure.

1 48. The method of claim 47, wherein the step of providing the first fluid in
2 the first microchannel having a first dissolved gas concentration comprises elevating a
3 temperature of the first fluid to a temperature greater than the first temperature prior to
4 introducing the first fluid into the first microscale channel.

1 49. The method of claim 47, wherein the step of providing the first fluid in
2 the first microchannel having a first dissolved gas concentration comprises subjecting the first
3 fluid to a pressure lower than the first pressure prior to introducing the first fluid into the first
4 microscale channel.

1 50. The method of claim 46, wherein the first fluid is heated to a
2 temperature at least about 5°C higher than the first temperature, prior to introducing the first
3 fluid into the first microchannel.

1 51. The method of claim 46, wherein the first microchannel has at least
2 one cross-sectional dimension between 0.1 and 100 μm .

1 52. A method of preventing bubble formation in a fluid containing
2 microchannel, comprising:
3 maintaining a first fluid at a first temperature prior to introducing the first fluid
4 into the microchannel;
5 applying a vacuum to the first microchannel to draw the first fluid into the first
6 microchannel; and
7 maintaining the first fluid at a second temperature once the first fluid is
8 introduced into the microchannel, the second temperature being less than the first
9 temperature.

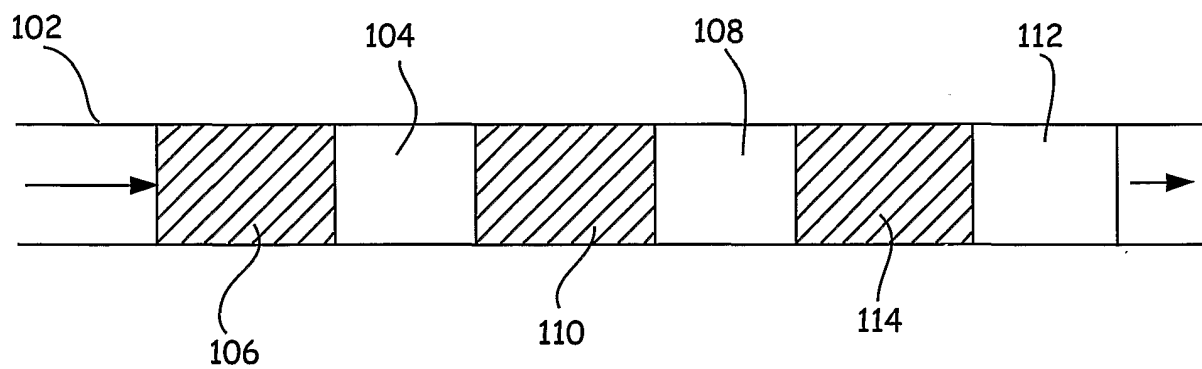

Figure 1

2/3

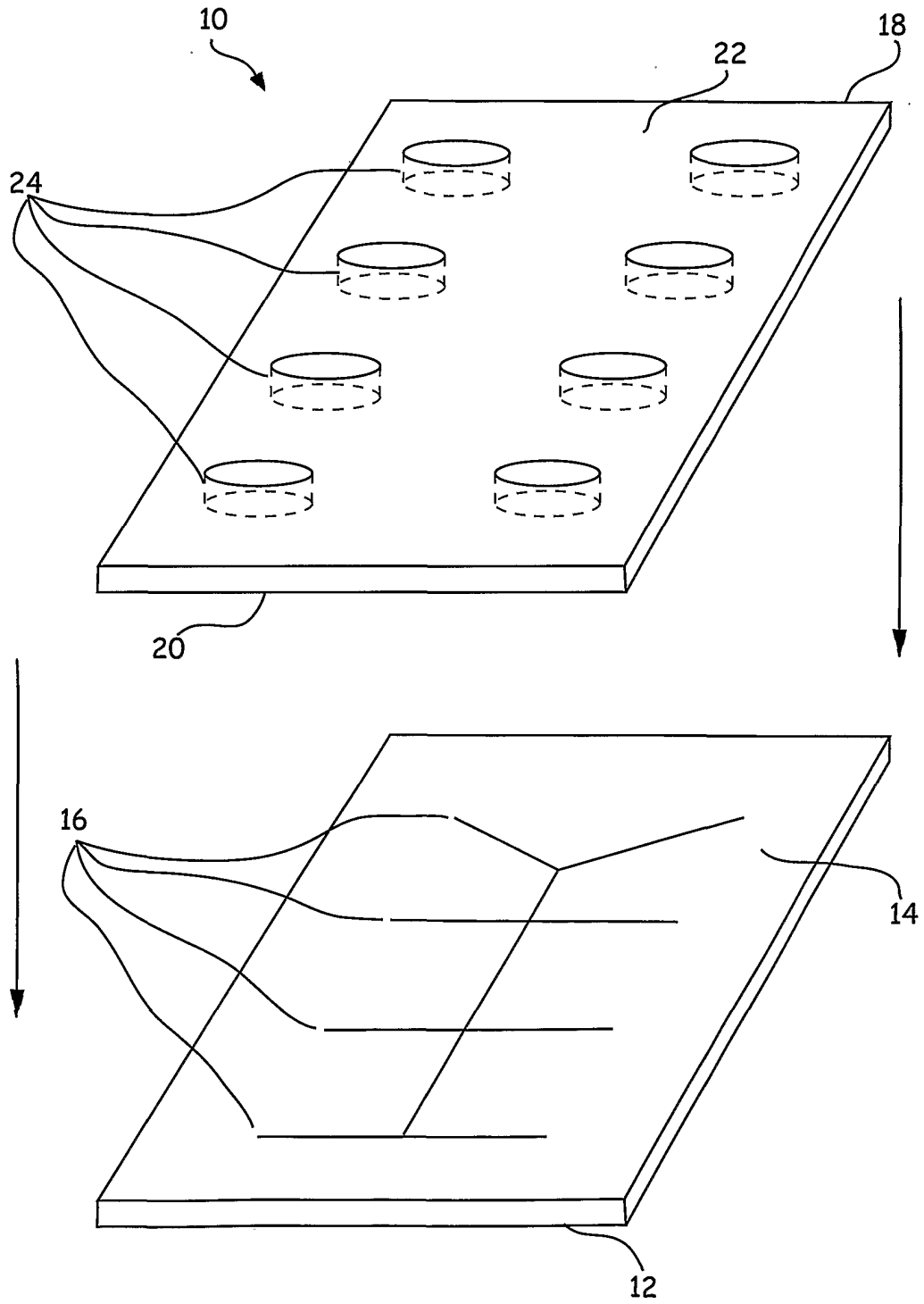

Figure 2

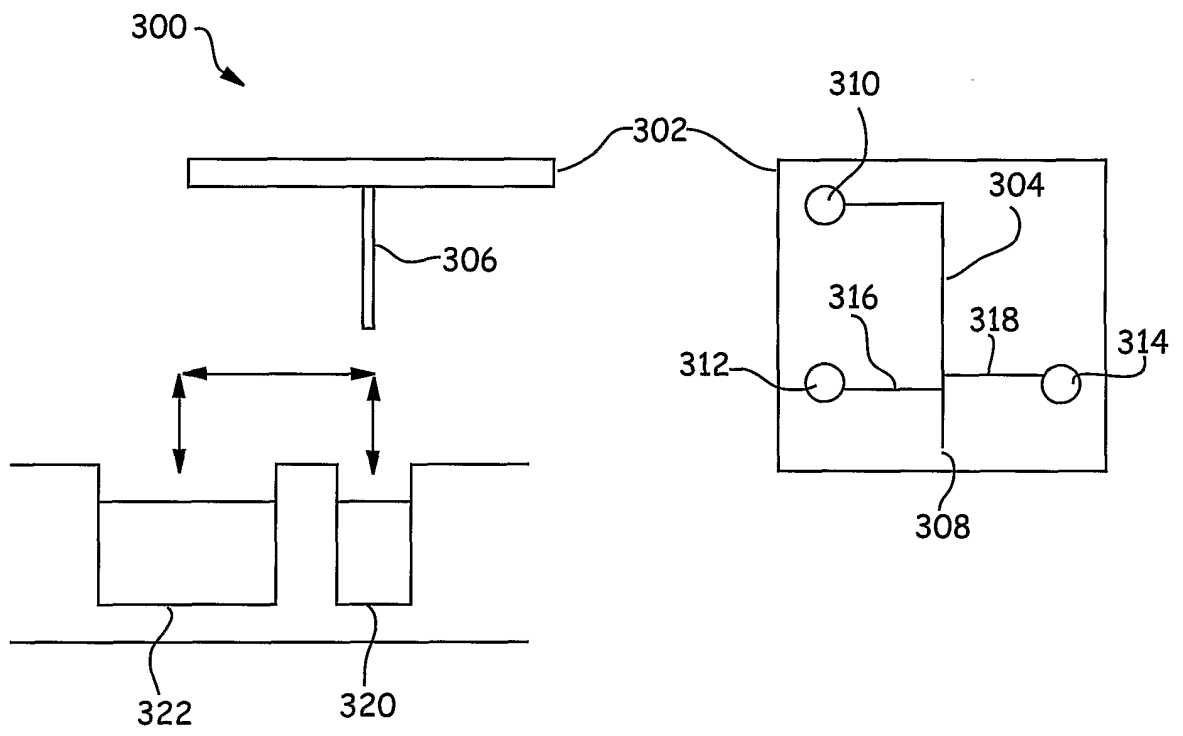

Figure 3

INTERNATIONAL SEARCH REPORT

International application No.
PCT/US01/24101

A. CLASSIFICATION OF SUBJECT MATTER
 IPC(7) : G01N 1/10; B01L 3/00, 3/02, 11/00; B01D 57/02, 59/42; C02F 1/40; 11/00
 US CL : 436/180; 422/99, 100, 102; 204/451, 601
 According to International Patent Classification (IPC) or to both national classification and IPC

B. FIELDS SEARCHED
 Minimum documentation searched (classification system followed by classification symbols)
 U.S. : 436/180; 422/99, 100, 102; 204/451, 601

Documentation searched other than minimum documentation to the extent that such documents are included in the fields searched

Electronic data base consulted during the international search (name of data base and, where practicable, search terms used)
 Please See Continuation Sheet

C. DOCUMENTS CONSIDERED TO BE RELEVANT

Category *	Citation of document, with indication, where appropriate, of the relevant passages	Relevant to claim No.
X	US 6,068,752 A (DUBROW et al.) 30 May 2000, entire document	1-7, 14, 19, 21-22, 25-31, 36, 40, 42-43, 45
X, P	US 6,149,787 A (CHOW et al.) 21 November 2000, entire document	1-7, 15-31, 36-45
Y, E	US 6,231,737 B1 (RAMSEY et al.) 15 May 2001, column 3 lines 41-65	1-6, 25-28
X	US 6,042,709 (PARCE et al.) 28 March 2000, entire document	1-7, 12-31, 36-45
A	US 6,186,660 B1 (KOPF-SILL et al.) 13 February 2001 entire document	1, 25

Further documents are listed in the continuation of Box C. See patent family annex.

* Special categories of cited documents:		"T"	later document published after the international filing date or priority date and not in conflict with the application but cited to understand the principle or theory underlying the invention
"A"	document defining the general state of the art which is not considered to be of particular relevance	"X"	document of particular relevance; the claimed invention cannot be considered novel or cannot be considered to involve an inventive step when the document is taken alone
"E"	earlier application or patent published on or after the international filing date	"Y"	document of particular relevance; the claimed invention cannot be considered to involve an inventive step when the document is combined with one or more other such documents, such combination being obvious to a person skilled in the art
"L"	document which may throw doubts on priority claim(s) or which is cited to establish the publication date of another citation or other special reason (as specified)	"&"	document member of the same patent family
"O"	document referring to an oral disclosure, use, exhibition or other means		
"P"	document published prior to the international filing date but later than the priority date claimed		

Date of the actual completion of the international search: 22 October 2001 (22.10.2001)
 Date of mailing of the international search report: 02 JAN 2002

Name and mailing address of the ISA/US: Commissioner of Patents and Trademarks, Box PCT, Washington, D.C. 20231, Facsimile No. (703)305-3230
 Authorized officer: Jill Warden, DEBORAH THOMAS, PARALEGAL SPECIALIST, Telephone No. (703) 308-0661

INTERNATIONAL SEARCH REPORT

International application No.

PCT/US01/24101

BOX II. OBSERVATIONS WHERE UNITY OF INVENTION IS LACKING

This application contains the following inventions or groups of inventions which are not so linked as to form a single general inventive concept under PCT Rule 13.1. In order for all inventions to be examined, the appropriate additional examination fees must be paid.

Group I, claim(s) 1-45, drawn to an apparatus and method of moving a volume of a reaction mixture.

Group II, claim(s) 46-52, drawn to a method of preventing bubble formation in a fluid microchannel.

The inventions listed as Groups I and II do not relate to a single general inventive concept under PCT Rule 13.1 because, under PCT Rule 13.2, they lack the same or corresponding special technical features for the following reasons: Group I does not require the method steps of Group II such as maintaining a temperature and pressure of the first fluid.

Continuation of B. FIELDS SEARCHED Item 3:

East and West

key terms: Spacer, degassing, channel, reaction, reagent

INTERNATIONAL SEARCH REPORT

International application No.

PCT/US01/24101

Box I Observations where certain claims were found unsearchable (Continuation of Item 1 of first sheet)

This international report has not been established in respect of certain claims under Article 17(2)(a) for the following reasons:

1. Claim Nos.:
because they relate to subject matter not required to be searched by this Authority, namely:

2. Claim Nos.:
because they relate to parts of the international application that do not comply with the prescribed requirements to such an extent that no meaningful international search can be carried out, specifically:

3. Claim Nos.:
because they are dependent claims and are not drafted in accordance with the second and third sentences of Rule 6.4(a).

Box II Observations where unity of invention is lacking (Continuation of Item 2 of first sheet)

This International Searching Authority found multiple inventions in this international application, as follows:
Please See Continuation Sheet

1. As all required additional search fees were timely paid by the applicant, this international search report covers all searchable claims.
2. As all searchable claims could be searched without effort justifying an additional fee, this Authority did not invite payment of any additional fee.
3. As only some of the required additional search fees were timely paid by the applicant, this international search report covers only those claims for which fees were paid, specifically claims Nos.:

4. No required additional search fees were timely paid by the applicant. Consequently, this international search report is restricted to the invention first mentioned in the claims; it is covered by claims Nos.: 1-45

Remark on Protest

The additional search fees were accompanied by the applicant's protest.

No protest accompanied the payment of additional search fees.