

(19) World Intellectual Property Organization
International Bureau



(43) International Publication Date
13 December 2007 (13.12.2007)

PCT

(10) International Publication Number
WO 2007/142619 A3

- (51) **International Patent Classification:**
F25B 1/10 (2006.01)
- (21) **International Application Number:**
PCT/US2006/021123
- (22) **International Filing Date:** 1 June 2006 (01.06.2006)
- (25) **Filing Language:** English
- (26) **Publication Language:** English
- (71) **Applicant (for all designated States except US):** **CARRIER CORPORATION** [US/US]; Center World Headquarters, One Carrier Place, Farmington, Connecticut 06034-4015 (US).
- (72) **Inventors; and**
- (75) **Inventors/Applicants (for US only):** **BUSH, James, W.** [US/US]; C/o Carrier Corporation, One Carrier Place, Farmington, Connecticut 06034-4015 (US). **BEAGLE, Wayne, P.** [US/US]; C/o Carrier Corporation, One Carrier Place, Farmington, Connecticut 06034-4015 (US). **MITRA, Biswajit** [IN/US]; C/o Carrier Corporation, One Carrier Place, Farmington, Connecticut 06034 (US).
- (74) **Agents:** **FAIRBAIRN, David, R.** et al; **KINNEY & LANGE, PA,** Kinney & Lange Building 312 South Third Street, Minneapolis, Minnesota 55415-1002 (US).

- (81) **Designated States (unless otherwise indicated, for every kind of national protection available):** AE, AG, AL, AM, AT, AU, AZ, BA, BB, BG, **BR**, BW, BY, BZ, CA, CH, CN, CO, CR, CU, CZ, DE, DK, DM, DZ, EC, EE, EG, ES, FI, GB, GD, GE, GH, GM, **HR**, HU, **ID**, IL, IN, IS, **JP**, KE, KG, KM, KN, KP, KR, KZ, LC, LK, LR, LS, LT, LU, LV, LY, MA, MD, MG, MK, MN, MW, MX, MZ, NA, NG, NI, NO, NZ, OM, PG, PH, PL, PT, RO, RU, SC, SD, SE, SG, SK, SL, SM, SY, TJ, TM, TN, TR, TT, TZ, UA, UG, US, UZ, VC, VN, YU, ZA, ZM, ZW
- (84) **Designated States (unless otherwise indicated, for every kind of regional protection available):** ARIPO (BW, GH, GM, KE, LS, MW, MZ, NA, SD, SL, SZ, TZ, UG, ZM, ZW), Eurasian (AM, AZ, BY, KG, KZ, MD, RU, TJ, TM), European (AT, BE, BG, CH, CY, CZ, DE, DK, EE, ES, FI, FR, GB, GR, HU, IE, IS, IT, LT, LU, LV, MC, NL, PL, PT, RO, SE, SI, SK, TR), OAPI (BF, BJ, CF, CG, CI, CM, GA, GN, GQ, GW, ML, MR, NE, SN, TD, TG).

Published:

- with international search report
- with amended claims and statement

(88) **Date of publication of the international search report:**
28 August 2008

Date of publication of the amended claims and statement:
9 October 2008

(54) **Title:** MULTI-STAGE COMPRESSOR UNIT FOR A REFRIGERATION SYSTEM

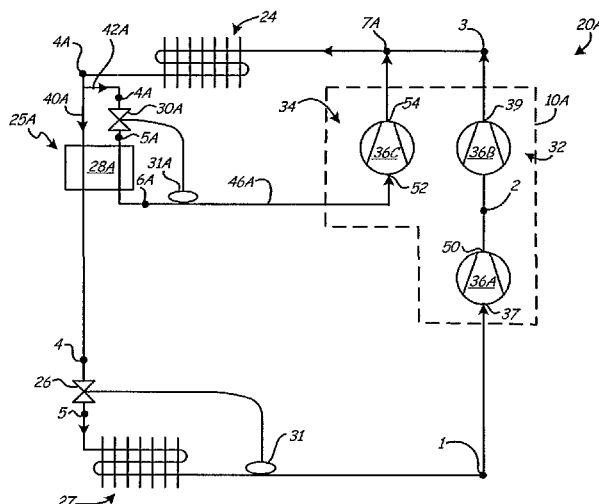

(57) **Abstract:** A multi-stage compressor unit for a refrigeration system configured to circulate a refrigerant comprises a first compressor sub-unit having a first stage and a second stage, and a second compressor sub-unit in parallel with the first compressor sub-unit and having a first stage. The first and second stages of the first compressor sub-unit each have a suction port and a discharge port. The first compressor sub-unit is configured to receive and compress a first portion of the refrigerant from an evaporator. The first stage of the second compressor sub-unit is configured to compress a second portion of the refrigerant.

WO 2007/142619 A3

received by the International Bureau on 09 June 2008 (09.06.09)

1. A multi-stage compressor unit for a refrigeration system configured to circulate a refrigerant, the multi-stage compressor unit comprising:
 - a first compressor sub-unit having a first stage and a second stage, wherein the first and second stages of the first compressor sub-unit each have a suction port and a discharge port, and wherein the first compressor sub-unit is configured to receive and compress a first portion of the refrigerant from an evaporator; and
 - a second compressor sub-unit in parallel with the first compressor sub-unit and having a first stage, wherein the first stage of the second compressor sub-unit has a suction port and a discharge port, and wherein the second compressor sub-unit is configured to compress a second portion of the refrigerant prior to the compressed second portion being combined with the compressed first portion.
2. The multi-stage compressor unit of claim 1, wherein the first stage of the second compressor sub-unit is configured to receive the second portion of the refrigerant from a second evaporator.
3. The multi-stage compressor unit of claim 1, wherein the first stage of the second compressor sub-unit is configured to receive the second portion of the refrigerant from a first economizer circuit.
4. The multi-stage compressor unit of claim 3, wherein the first compressor sub-unit further comprises an interstage port disposed between the discharge port of the first stage and the suction port of the second stage, and wherein the interstage port is configured to receive a third portion of the refrigerant from a second economizer circuit.
5. The multi-stage compressor unit of claim 1, wherein the first compressor sub-unit and the second compressor sub-unit comprise reciprocating compressors.

6. The multi-stage compressor unit of claim 1, wherein the refrigerant is a transcritical refrigerant
7. The multi-stage compressor unit of claim 1, and further comprising an intercooler configured to cool the first portion of the refrigerant between the first and second stages of the first compressor sub-unit.
8. The multi-stage compressor unit of claim 1, wherein the second compressor sub-unit is configured to discharge into an interstage port of the first compressor sub-unit.
9. The multi-stage compressor unit of claim 1, wherein the second compressor sub-unit further comprises a second stage having a suction port and a discharge port, and wherein the first and second stages of the second compressor sub-unit are connected in series.
10. A multi-stage compressor unit for a refrigeration system having a first economizer circuit and configured to circulate a refrigerant, the multi-stage compressor unit comprising:
 - a first compressor sub-unit having a first stage and a second stage, wherein the first compressor sub-unit is configured to receive and compress a first portion of the refrigerant from an evaporator, and
 - a second compressor sub-unit in parallel with the first compressor sub-unit, wherein the second compressor sub-unit is configured to compress a second portion of the refrigerant from the first economizer circuit prior to the compressed second portion being combined with the compressed first portion.
11. The multi-stage compressor unit of claim 10, and further comprising an intercooler configured to cool the first portion of the refrigerant between the first and second stages of the first compressor sub-unit.

12. The multi-stage compressor unit of claim 10, wherein the first compressor sub-unit is configured to discharge refrigerant at a first exit pressure, and wherein the second compressor sub-unit is configured to discharge refrigerant at a second exit pressure.

13. The multi-stage compressor unit of claim 12, wherein the first and second exit pressures are substantially equivalent.

14. The multi-stage compressor unit of claim 10, wherein the first compressor sub-unit further comprises an interstage port disposed between the first and second stages and configured to receive a third portion of the refrigerant from a second economizer circuit, and wherein the second stage of the first compressor sub-unit is configured to compress a mixture of the first and third portions of the refrigerant.

15. The multi-stage compressor unit of claim 10, wherein the second compressor sub-unit is a single-stage compressor.

16. The multi-stage compressor unit of claim 10, wherein the second compressor sub-unit is a two-stage compressor.

17. The multi-stage compressor unit of claim 16, wherein the second compressor sub-unit further comprises an interstage port configured to receive a fourth portion of the refrigerant from a third economizer circuit.

18. A multi-stage compressor unit for a refrigeration system configured to circulate a refrigerant, the multi-stage compressor unit comprising:

a first compressor sub-unit having a first stage, a second stage, and an interstage port disposed between the first and second stages, wherein the first stage of the first compressor sub-unit is configured to compress a first portion of the refrigerant to an intermediate pressure, and wherein the second stage of the first compressor sub-unit is configured to compress the first portion of the refrigerant to an exit pressure of the first compressor sub-unit; and

a second compressor sub-unit having a first stage, wherein the second compressor sub-unit is configured to compress a second portion of the refrigerant to an exit pressure of the second compressor sub-unit prior to the compressed second portion being combined with the compressed first portion.

19. The multi-stage compressor unit of claim 18, wherein the exit pressures of the first compressor sub-unit and the second compressor sub-unit are substantially equivalent.

20. The multi-stage compressor unit of claim 18, wherein the second compressor sub-unit discharges the second portion of the refrigerant into the interstage port of the first compressor sub-unit, and wherein the exit pressure of the second compressor sub-unit is substantially equivalent to the intermediate pressure of the first compressor sub-unit.

This is in response to the Written Opinion of the International Searching Authority dated 07 April 2008. Enclosed are replacement sheets 20-23. With this amendment, claims 1, 10, and 18 have been amended. Claims 2-9, 11-17, 19, and 20 remain unchanged. Specific claim amendments reflected in the replacement sheets are as follows:

Claim 1 has been amended to add the clause "prior to the compressed second portion being combined with the compressed first portion".

Claim 10 has been amended to add the clause "prior to the compressed second portion being combined with the compressed first portion".

Claim 18 has been amended to add the clause "prior to the compressed second portion being combined with the compressed first portion".