

J. CODY.

Improvement in Rock-Drilling Machines.

No. 130,412.

Fig. 1.

Patented Aug. 13, 1872.

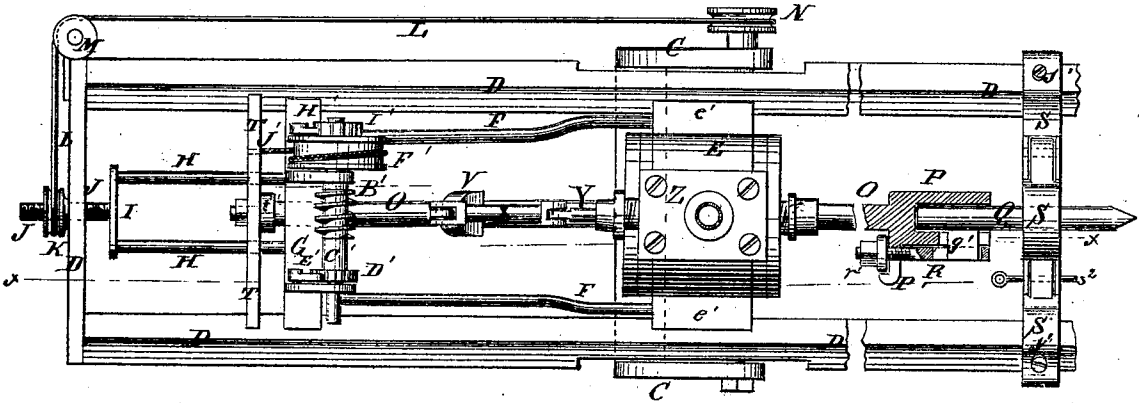

Fig. 4.

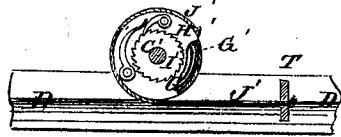

Fig. 2.

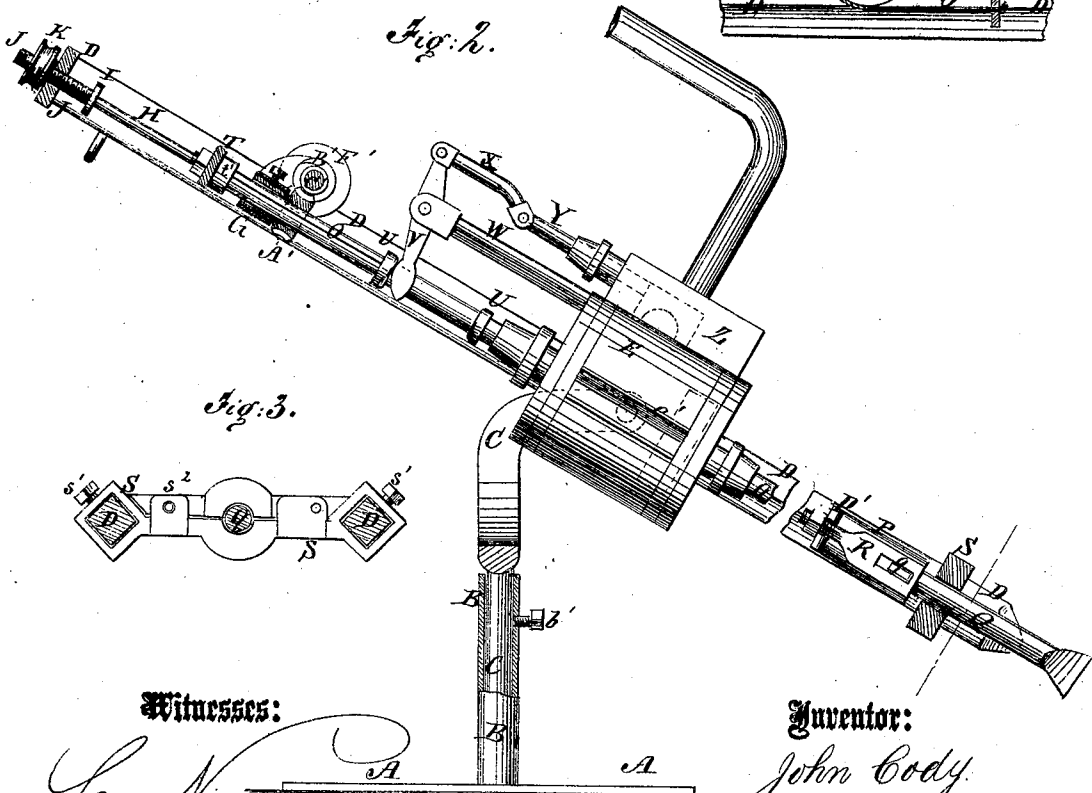
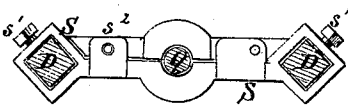

Fig. 3.



Witnesses:

Chas. Nide
N. A. Graham

Inventor:

John Cody
Munnell
 Attorneys.

UNITED STATES PATENT OFFICE.

JOHN CODY, OF NEW YORK, N. Y.

IMPROVEMENT IN ROCK-DRILLING MACHINES.

Specification forming part of Letters Patent No. 130,412, dated August 13, 1872.

Specification describing a new and useful Improvement in Steam-Drill, invented by JOHN CODY, of the city, county, and State of New York.

Figure 1 is a top view of my improved machine. Fig. 2 is a detail longitudinal section of the same taken through the line *xx*, Fig. 1. Fig. 3 is a detail cross-section of the same taken through the line *yy*, Fig. 2. Fig. 4 is a detail view of the device for rotating the drill.

Similar letters of reference indicate corresponding parts.

My invention has for its object to furnish an improved steam-drill which shall be simple in construction and convenient in use, enabling a hole to be drilled in a horizontal direction or at any desired angle; and it consists in the construction and combination of various parts of the machine, as hereinafter more fully described.

A is the base frame or plate of the machine, which should be made of such a size and weight as to firmly support and ballast the machine. To the plate or frame A is securely attached a post, B, which is made hollow to receive the standard C, which standard is secured at any desired height by a set-screw, *b'*, which passes in through the side of the post A and against or into the standard B. The upper part of the standard C is made branched, which branches are curved outward and upward, and their ends are bent forward to bring the pivoting points about in line with the center of gravity of the machine. To the ends of the branches of the standard C is pivoted the frame D of the machine, which frame consists of two side bars, of a suitable size, connected at their upper ends by a cross-bar. The side bars of the frame D are arranged diagonally with respect to each other, as shown in Fig. 3, and have their forward ends pointed, as indicated in Fig. 2, to rest against the rock and steady the machine while being operated. E is the steam-cylinder, which is placed between and parallel with the side bars of the frame D, and which has flanges *e'* formed upon its sides, and grooved longitudinally to fit and slide upon the inner angles of the side bars of the frame D, as shown in Fig. 1. To the flanges *e'* of the steam-cylinder E are attached the lower ends of two rods, F, the upper ends of which enter or are securely attached to a cross bar, G. The

ends of the cross-bar G are notched to fit and slide upon the inner angles of the side bars of the frame D. To the cross-bar G are attached the lower ends of two short rods, H, to the upper ends of which is attached a short cross-bar or yoke, I. To the center of the short cross-bar I is attached the end of a rod, J, which passes up through the cross-bar of the frame D, and has a screw-thread formed upon it to receive a nut, K. The steam-cylinder and drill are thus hung from the cross-bar of the frame D by the screw J and nut K, and are fed down or forward as the drill cuts its way into the rock by simply turning the nut K. The nut K is grooved to receive an endless chain, L, which passes over guide-pulleys M pivoted to the corner of the frame D, down along the side bar of said frame, and around a pulley or wheel, N, which is pivoted to said side bar at or near its pivoting point. The pulley N should be provided with a crank or hand wheel, to enable the drill to be fed down or drawn up, as required. O is the piston-rod of the steam-cylinder E, which rod O passes out through both the heads of said cylinder, and to its lower end is attached or upon it is formed a socket, P, to receive the drill Q. The socket P is slotted upon one side of its lower end, and has an outwardly-projecting slotted lug, P', formed upon the side of its upper end. The drill Q is made with an outwardly-projecting lug, *q'*, upon the side of its upper end to enter the slot of the socket P. R is a small plate, the inner side of which is concaved to fit upon the side of the socket P. The lower part of the plate R has a slot formed in it to receive the lug *q'* of the drill Q. The upper end of the plate R is made narrow to enter the slot of the lug P', is rounded off, and has a screw-thread cut upon it to receive the nut *r'*, which rests against the upper side of the lug P', so as to lock the drill Q securely in place, and at the same time in such a way that the drill may be easily detached and attached when desired. The drill Q works up and down in a hole in the center of the guide-bar S, the ends of which have holes formed through them to receive, fit, and slide upon the side bars of the frame D, to which they are adjustably secured by set-screws *s'*, as shown in Figs. 1 and 3. The middle part of the bar S, through which the drill Q passes, is made in two parts, one of

which is hinged at one end to the other part, and is secured at the other end when closed by a pin, s^2 , as shown in Fig. 1, so that it may be conveniently opened, when desired, to remove the drill. The upper end of the piston-rod O passes up through a hole in the cross-bar G, and to it is attached the cross-bar T, the ends of which are notched to receive, fit, and slide upon the inner angles of the side bars of the frame D. A rubber spring, t' , being interposed between the rail-bar T and the shoulder of the piston-rod O to receive the rebound of the drill and prevent jar when the drill strikes the rock. The bar T has holes formed in it for the passage of the rods H, so that the said rods and bar may move independent of each other. To the piston-rod O, a little above the cylinder E, are attached two collars, U, at a little distance apart. Upon the piston-rod O, between the collars U, is placed the forked end of a lever, V, which is pivoted to a standard, W, attached to the upper end of the cylinder E. To the outer end of the lever V, is pivoted one end of a short connecting-rod, X, the other end of which is pivoted to the outer end of the valve-stem Y, which passes out through the end of the steam-chest Z.

By this arrangement the movement of the piston in the cylinder E will operate the valve to admit and shut off the steam from said cylinder. The collars U should be adjustably secured to the piston-rod O, so that by adjusting the said collars the steam may be admitted and shut off at any desired point of the stroke.

A' is a screw-wheel (Fig. 2) which has a short tubular shaft that is swiveled in or to the cross-bar G. Said wheel is connected with the piston-rod O by a tongue and groove, so that the said screw-wheel A' may carry the said piston-rod O with it in its revolution, while allowing the said piston-rod to move up and down through it freely. Into the threads of the screw-wheel A' mesh the threads of an endless screw, B', formed upon the shaft C', which revolves in bearings attached to the cross-bar G. To the shaft C' is attached to a ratchet-wheel, D', with the teeth of which the pawl E' engages to keep the said shaft from being turned back. The pawl E' is pivoted to the cross-bar G or to the bearing for the screw-shaft C', and is held forward against the teeth of the ratchet-wheel D' by a spring. To the end of the screw-shaft C' is pivoted a drum, F', in which is coiled a spring, G', one end of which is attached to the drum F', and its other end is attached to the screw-shaft C'. To the end of the drum F' is at-

tached a spring-pawl, H', which engages with the teeth of the ratchet-wheel I' attached to the shaft C'. To the drum F' is attached one end of a cord or chain, J', which is coiled around said drum and its other end is attached to the cross-bar T.

By this arrangement, as the drill Q and piston-rod O are raised or drawn back, the cord J is uncoiled from the drum F', which rotates the drum and causes the pawl H' acting upon the ratchet-wheel I', to rotate the screw-shaft C', the screw B' of which, acting upon the screw-wheel A', rotates the piston-rod O, and drill Q. As the piston-rod O and drill Q descend or move forward, the descent of the bar T allows the spring G' to turn back the drum F' and wind up the cord J' ready for another stroke, the pawl H' sliding over the teeth of the ratchet-wheel I, and the pawl E', and ratchet-wheel D', holding the screw-shaft B' C' from being turned back by friction. The drill is thus rotated during its upward movement by its own motion.

Having thus described my invention, I claim as new and desire to secure by Letters Patent—

1. The combination of the base-plate or frame A, hollow post B, and branched standard C, with the frame D, of a steam-drill to support said drill in such a way that it may operate at any desired angle, substantially as herein shown and described.

2. The frame D, steam-cylinder E having grooved flanges, e' , formed on its sides, the two rods F, cross-bar G, two rods H, cross-bar I, screw J, nut K, and feed-chain L, in combination with each other, substantially as herein shown and described to enable the drill to be fed forward to its work by hand, as set forth.

3. The combination of the socket P, lug P', plate R, and nut r' , and lug g' , with the drill Q, and piston-rod O, substantially as herein shown and described, and for the purpose set forth.

4. The combination of the swiveled screw-wheel A', endless screw B', shaft C', ratchet-wheel D' and pawl E', drum F', spring G', pawl H' and ratchet-wheel I' and cord J' with each other and with the cross-bar G, piston-rod O, and cross-bar T, to rotate the drill automatically as it moves back after making a stroke, substantially as herein shown and described.

JOHN CODY.

Witnesses:

JAMES T. GRAHAM,
T. B. MOSHER.