



(12) **EUROPEAN PATENT APPLICATION**

(43) Date of publication:
10.12.2014 Bulletin 2014/50

(51) Int Cl.:
H01F 38/00 (2006.01) H01F 3/12 (2006.01)

(21) Application number: **13170704.4**

(22) Date of filing: **05.06.2013**

(84) Designated Contracting States:
AL AT BE BG CH CY CZ DE DK EE ES FI FR GB GR HR HU IE IS IT LI LT LU LV MC MK MT NL NO PL PT RO RS SE SI SK SM TR
 Designated Extension States:
BA ME

- **Aye, Andreas**
8033 Strassen (LU)
- **Kneppers, Gerard J.**
6760 Virton (BE)

(71) Applicant: **Delphi Automotive Systems Luxembourg SA**
4940 Bascharage (LU)

(74) Representative: **Allain, Michel Jean Camille et al**
Legal Staff - Patents
Delphi France SAS
Bât. le Raspail - ZAC Paris Nord 2
22, avenue des Nations
CS 65059 Villepinte
95972 Roissy CDG Cedex (FR)

(72) Inventors:
 • **Heise, Volker**
54292 Trier (DE)

(54) **Transformer**

(57) A transformer comprises a magnetic core and a magnetic return path element providing a magnetic return path for the magnetic core. The magnetic core is generally located between two end faces of the magnetic return path element. A primary coil or winding surrounds the magnetic core. A secondary coil or winding surrounds

the primary winding/coil. A first gap component is located between one end of the magnetic core and one corresponding end face of the magnetic return path element. A second gap component is located between the other end of the magnetic core and the corresponding other end face of the magnetic return path element.

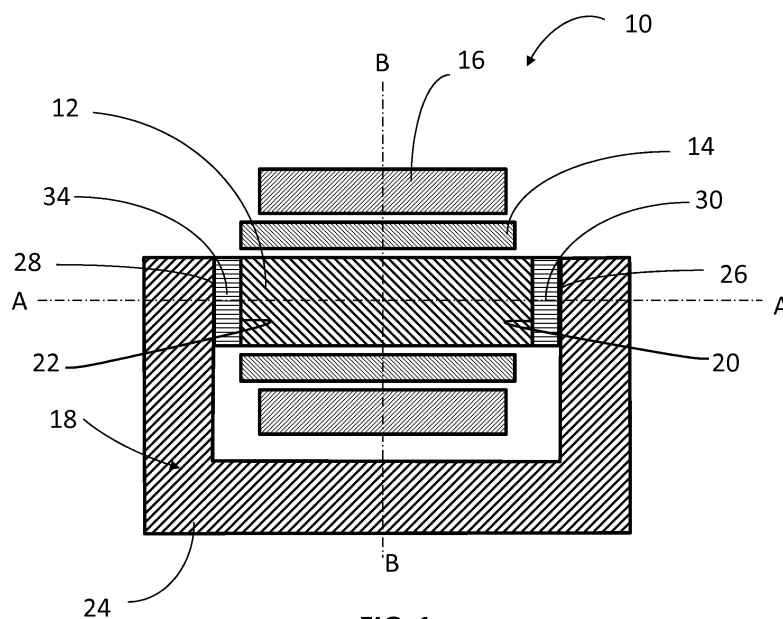

FIG. 1

Description

TECHNICAL FIELD

[0001] This disclosure relates to a transformer and has particular, but not exclusive application, to a transformer for an ignition apparatus or coil, such as for, but not limited to, automotive applications.

BACKGROUND OF THE INVENTION

[0002] Conventional ignition coils are realized with gapped transformers. The transformers generally include a core of magnetic highly permeable material, around which primary and secondary windings are located. A closed magnetic return path is provided by a generally C or U shaped magnetic return path element, the magnetic core being located between two end faces of the return path element. Preferred materials for the magnetic core and for the magnetic return path element are laminated metal sheets.

[0003] Typically, one end of the magnetic core directly abuts or contacts one end face of the magnetic return path element. Between the other end face of the magnetic return path element and the other end of the core is typically located a magnet or simply an air-gap. During the operation of such a coil transformer, heat is created dominantly by ohmic losses in the primary and secondary winding.

[0004] Magnetic saturation zones can be created at interfaces between the magnetic return path element and the magnetic core. Saturation is built-up inside the magnetic return path element, around the interface region to the magnetic core. Generally such saturation causes a problem in that it limits the performance of the entire magnetic circuit. Known solutions are to increase the cross-sections of the magnetic path element or use magnetic material with higher magnetic permeability. Either solution is not desired because it increases weight, volume and/or cost.

[0005] It is an object of the invention to provide an improved transformer that overcomes such problems.

SUMMARY OF THE INVENTION

[0006] In one aspect of the invention is provided a transformer comprises a magnetic core and a magnetic return path element providing a magnetic return path for the magnetic core. The magnetic core is generally located between two end faces of the magnetic return path element. A primary coil or winding surrounds the magnetic core. A secondary coil or winding surrounds the primary winding/coil. A first gap component is located between one end of the magnetic core and one corresponding end face of the magnetic return path element. A second gap component is located between the other end of the magnetic core and the corresponding other end face of the magnetic return path element. The second

gap component is located symmetrically to the first gap component in the magnetic core about an axis perpendicular to the core axis. The magnetic core, the magnetic return path element, the primary winding and the secondary winding are encapsulated by an encapsulated material which is an epoxy resin. The gap components comprises spacers encapsulated inside the epoxy resin material. The two gap components are formed from an electrical isolating material and at least for one spacer from a material with a thermal conductivity greater than 1 W/m/K. The two gap components are formed from a ceramic material including aluminum-oxide or aluminum-nitrides. A heat sink surrounds a substantial portion of the transformer. The heat sink includes a bracket. An electronic board is attached to the heat sink. The transformer includes an insulating housing. An ignition coil includes a transformer.

[0007] Further features, uses and advantages of the invention will appear more clearly on a reading of the following detailed description of the embodiments of the invention, which is given by way of non-limiting example only and with reference to the accompanying drawings.

BRIEF DESCRIPTION OF THE DRAWINGS

[0008] This invention will be further described by way of example and with reference to the accompanying drawings in which:

Figure 1 shows a schematic longitudinal section through transformer of an ignition coil, in accordance with one basic example of the invention.

Figure 2 shows a schematic longitudinal section through transformer of an ignition coil, in accordance with a further example of the invention.

Figure 3 shows a schematic longitudinal section through transformer of an ignition coil, in accordance with another example of the invention.

DETAILED DESCRIPTION OF THE PREFERRED EMBODIMENTS

[0009] Figure 1 shows a simple transformer according to one embodiment of the invention. The transformer comprises a magnetic core 12, a primary winding 14 and secondary winding 16, a magnetic return path element 18 and a first gap component 30. The magnetic core 12 extending along a longitudinal axis 'A' is generally cylindrical in overall shape and includes two ends 20 and 22. The magnetic return path element 18 is configured to provide a high permeability magnetic return path, and has a base section 24 and two end faces 26 and 28. The typical width for gap component 30 is 0.5 to 2 mm. Gap components could have different thickness.

[0010] A second gap component 34 is located symmetrically to the first gap component 30. More precisely, the first and the second gap component 30 and 34 are located between each end faces of section 26 and 28 of

the magnetic return path element 18 and the respective ends 20 and 22 of the magnetic core 12. The magnetic core 12 in combination with the magnetic return path element 18, and gap components form a magnetic circuit having a high magnetic permeability.

[0011] The two gap components 30 and 34 may be formed from ceramic or other material. Preferably this material has a heat conductivity greater than 1 W/m/K. The choice of using heat conducting material for one or two gap components 30 and 34 can be selected to dissipate heat generated by the primary winding 14 and the secondary winding 16 from the magnetic core 12 to the magnetic return path element 18 either with a preferential direction or symmetrically. Preferably the gap components 30 and 34 are formed from materials such as ceramics; for example ceramics including aluminum-oxide, aluminum-nitrides or any similar materials. The additional second gap component 34, arranged symmetrically about the transverse axis 'B' to the first gap component 30 in the magnetic core 12, allows balancing of the magnetic circuit and by this allows an increase the total flux of the circuit. As an example, one gap component could be realized by a permanent magnetic material, whereas the second gap could be made out of any filling material, preferably with high thermal conductivity. This transformer topology increases the output performance of the transformer 10 and provides for a smaller more compact transformer.

[0012] Figure 2 shows a transformer according to another embodiment of the invention. The transformer comprises again a magnetic core 12, a primary winding 14 and secondary winding 16, a magnetic return path element 18 and two gap components 30 and 34. The transformer is encapsulated within e.g. an epoxy material 32 with typical heat conductivities in the range of 0.1 to 1 W/m/K, to provide electrical insulation. The two gap components 30 and 34 encapsulated inside the epoxy 32 potting material may be provided by spacers. The two gap components allow balancing of the magnetic circuit and by this allow an increase the total flux of the circuit. The spacers provide the advantage of a lighter transformer.

[0013] The epoxy potting material 32 also provides protection from environmental factors which may be encountered during the service life of the transformer. During the operation of the transformer 10, heat is created dominantly by ohmic losses of the primary winding 14 and secondary winding 16. This heat is conducted through the epoxy 32 encapsulation of the transformer to the surface. The transformer 10 may have an insulating plastic housing 38 in order to attach, for instance, connectors. This transformer topology increases the output performance of the transformer 10 or to further miniaturize its magnetic circuit.

[0014] Figure 3 illustrates a further refined and preferred embodiment of the invention. The drawing shows similar components and reference numerals as before. The embodiment further however includes a heat sink

36 and an electronic circuit board 40.

[0015] The heat sink 36 may be attached to the magnetic return path element 18 providing a large surface to reduce the internal temperature of the primary winding 14 and secondary winding 16 during transformer operation. The heat sink 36 can be attached by means of an over-mold, welding, clamping directly or any similar method, to the magnetic return path element 18. The heat sink 36 is preferably made of magnetic or non-magnetic metal material and allows heat to flow outside of the plastic housing 38. The heat sink 36 may have additional means to attach to an integrated electronic circuit board 40 and serves by this for dissipating the heat from the electronic circuit board 40. The electronic circuit board is preferably used as an electronic control board for the ignition coil comprising the transformer 10.

[0016] The heat sink 36 may further be formed as a bracket that can be fixed to a vehicle chassis. Optionally the bracket can be split into at least two individual elements. The thickness and contact surface of the heat sink 36 can be varied so as to provide desired heat dissipation requirements. The shape of the heat sink 36 is preferably conforms to the shape of the outer surface of the magnetic return path element 18. Within the invention, ignition coil topology allows balancing the magnetic circuit and by this allows increasing the total flux of the circuit. This can be used either to increase the output performance or to further miniaturize the magnetic circuit

Claims

1. A transformer (10) comprising:

- a magnetic core (12);
- a magnetic return path element (18) providing a magnetic return path for the magnetic core (12); said magnetic core being generally located between two end faces (26, 28) of the magnetic return path element (18);
- a primary coil or winding (14), surrounding the magnetic core (12);
- a secondary coil or winding (16) surrounding the primary winding/coil (14);
- a first gap component (30) located between one end (20) of the magnetic core (12) and one corresponding end face (26) of the magnetic return path element (18);
- characterized in that** a second gap component (34) is located between the other end (22) of the magnetic core (12) and the corresponding other end face (28) of the magnetic return path element (18).

2. A transformer (10) as claimed in claim 1 wherein said second gap component (34) is located symmetrically to the first gap component (30) in the magnetic core (12) about an axis perpendicular to the core

axis.

3. A transformer (10) as claimed in any previous claims wherein the magnetic core (12), the magnetic return path element (18), the primary winding (14) and the secondary winding (16) are encapsulated. 5

4. A transformer (10) as claimed in claim 3 wherein the encapsulating material is an epoxy resin (32). 10

5. A transformer (10) as claimed in any previous claims wherein at least one of the gap components (30, 34) is formed from an electrical isolating material. 15

6. A transformer (10) as claimed in any previous claims wherein at least one of the gap components (30, 34) are formed from a material with a thermal conductivity greater than 1 W/m/K. 20

7. A transformer (10) as set in any of previous claims wherein the two gap components (30, 34) are formed from a ceramic material.

8. A transformer (10) as claimed in claim 7 wherein said ceramic material includes aluminum-oxide or aluminum-nitrides. 25

9. A transformer (10) as claimed in any of previous claims further including a heat sink (36) surrounding a substantial portion of said transformer (10). 30

10. A transformer (10) as claimed in claim 9 wherein said heat sink includes a bracket. 35

11. A transformer (10) as claimed in claims 9 or 10 wherein an electronic board (40) is attached to the heat sink (36).

12. A transformer (10) as claimed in any of previous claims including an insulating housing (38). 40

13. An ignition coil including a transformer (10) as claimed in any preceding claim. 45

50

55

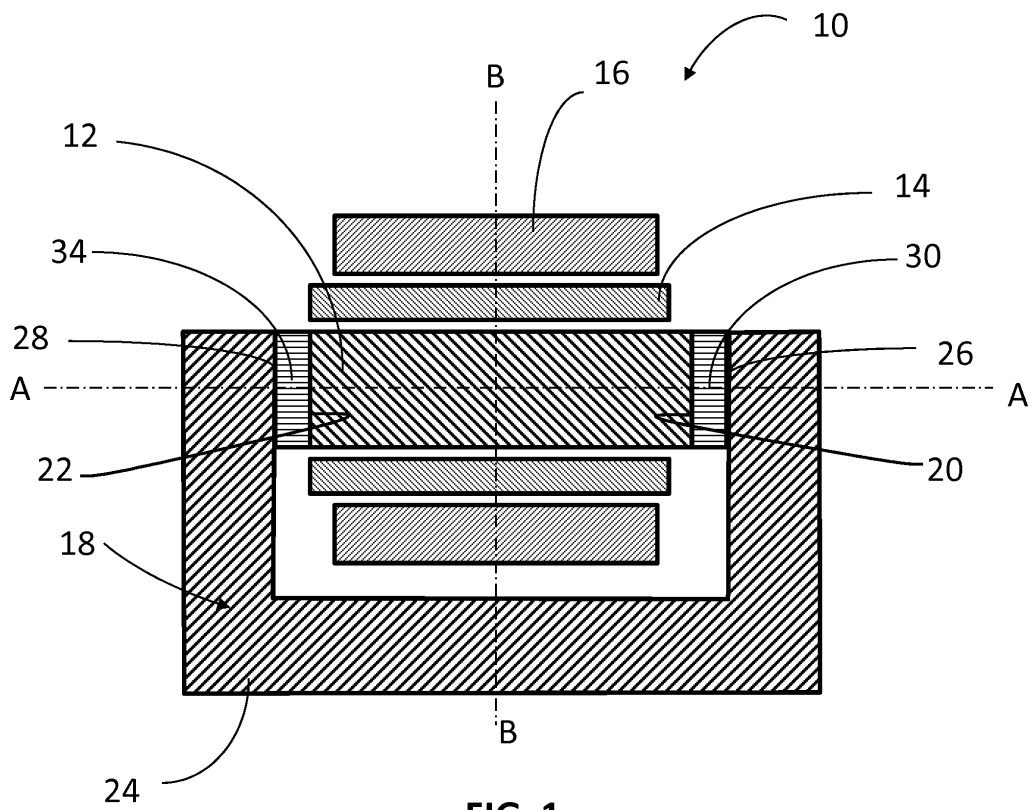

FIG. 1

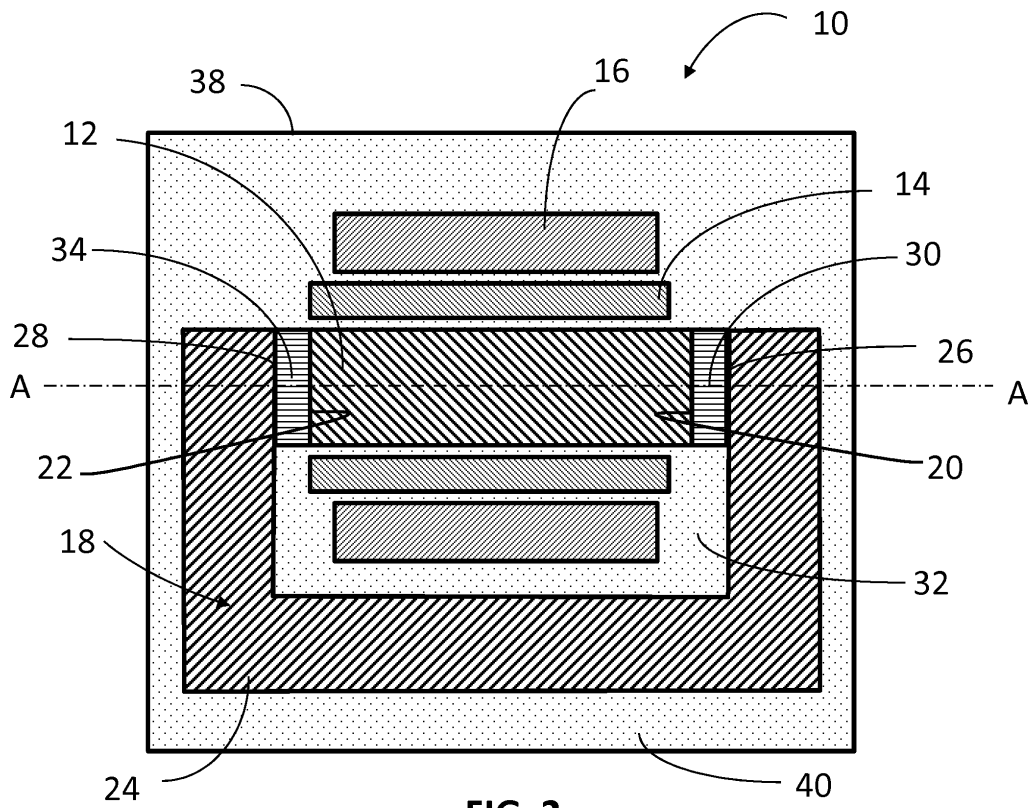

FIG. 2

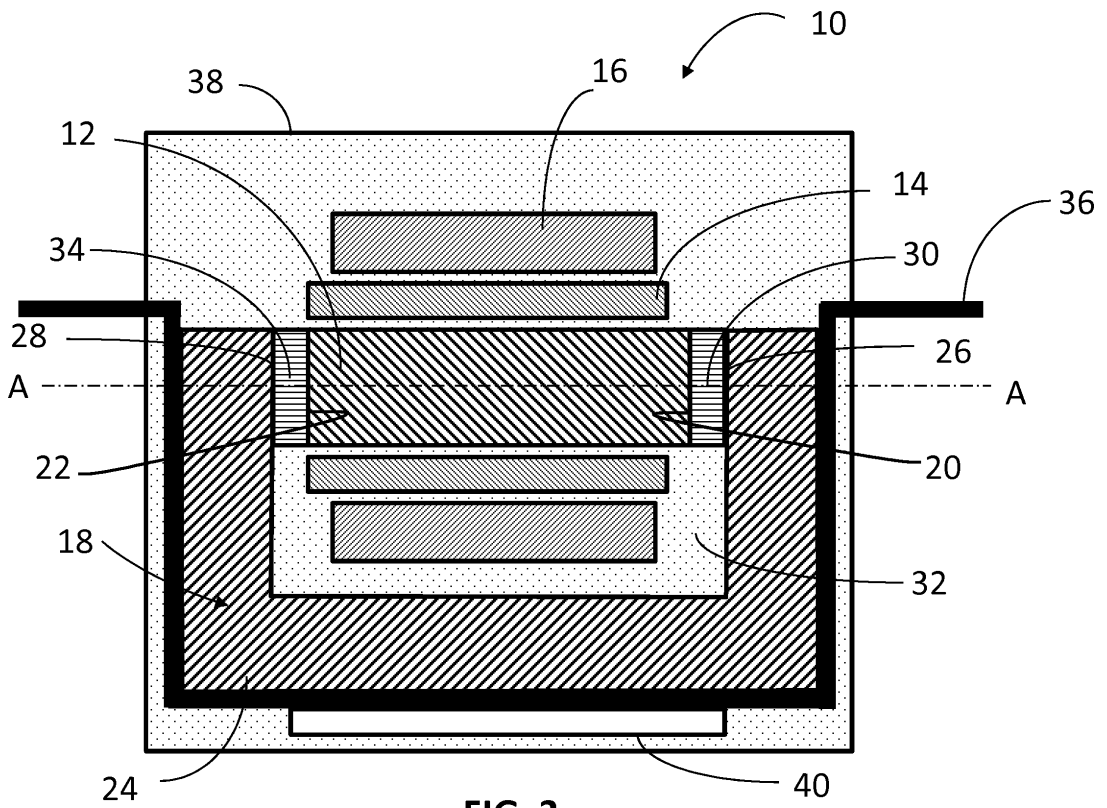

FIG. 3



EUROPEAN SEARCH REPORT

Application Number
EP 13 17 0704

5

10

15

20

25

30

35

40

45

50

55

DOCUMENTS CONSIDERED TO BE RELEVANT			
Category	Citation of document with indication, where appropriate, of relevant passages	Relevant to claim	CLASSIFICATION OF THE APPLICATION (IPC)
X	US 2004/085174 A1 (DECRISTOFARO NICHOLAS J [US] ET AL) 6 May 2004 (2004-05-06)	1-8	INV. H01F38/00 H01F3/12
Y	* paragraph [0054]; figures 3b,3c * * paragraph [0053] * * paragraph [0051] * * paragraph [0052] *	9-13	
X	US 2004/085173 A1 (DECRISTOFARO NICHOLAS J [US] ET AL) 6 May 2004 (2004-05-06)	1-8	
Y	* paragraph [0050]; figures 2b,2c * * paragraph [0048] *		
Y	EP 0 913 841 A1 (FORD MOTOR CO [US]) 6 May 1999 (1999-05-06)	9-12	
Y	* paragraph [0002] - paragraph [0004] *		
Y	EP 0 283 354 A1 (MARCHAL EQUIP AUTO [FR]) 21 September 1988 (1988-09-21)	13	
	* abstract; figure 1 *		
A	EP 2 498 266 A2 (HITACHI LTD [JP]) 12 September 2012 (2012-09-12)	1-13	TECHNICAL FIELDS SEARCHED (IPC)
	* paragraph [0022]; figure 3 *		H01F
A	EP 2 518 740 A1 (TAMURA SEISAKUSHO KK [JP]) 31 October 2012 (2012-10-31)	1	
	* figure 13 *		
A	CN 202 258 665 U (TONGXIANG ZHONGXIN CHEMICAL FIBER CO LTD) 30 May 2012 (2012-05-30)	9-12	
	* the whole document *		

The present search report has been drawn up for all claims			
Place of search Munich		Date of completion of the search 15 November 2013	Examiner Rouzier, Brice
CATEGORY OF CITED DOCUMENTS		T : theory or principle underlying the invention E : earlier patent document, but published on, or after the filing date D : document cited in the application L : document cited for other reasons & : member of the same patent family, corresponding document	
X : particularly relevant if taken alone Y : particularly relevant if combined with another document of the same category A : technological background O : non-written disclosure P : intermediate document			

EPC FORM 1503, 03.82 (F04C01)

**ANNEX TO THE EUROPEAN SEARCH REPORT
ON EUROPEAN PATENT APPLICATION NO.**

EP 13 17 0704

5

This annex lists the patent family members relating to the patent documents cited in the above-mentioned European search report. The members are as contained in the European Patent Office EDP file on
The European Patent Office is in no way liable for these particulars which are merely given for the purpose of information.

10

15-11-2013

15

20

25

30

35

40

45

50

55

Patent document cited in search report	Publication date	Patent family member(s)	Publication date
US 2004085174 A1	06-05-2004	AU 2003285156 A1	07-06-2004
		CN 101027733 A	29-08-2007
		CN 102290204 A	21-12-2011
		EP 1563518 A2	17-08-2005
		HK 1111515 A1	24-08-2012
		JP 2006505142 A	09-02-2006
		JP 2010258477 A	11-11-2010
		KR 20050067222 A	30-06-2005
		US 2004085174 A1	06-05-2004
		US 2006066433 A1	30-03-2006
WO 2004042746 A2	21-05-2004		
US 2004085173 A1	06-05-2004	AU 2003290623 A1	07-06-2004
		CN 1735948 A	15-02-2006
		EP 1565920 A1	24-08-2005
		HK 1086941 A1	02-02-2011
		JP 2006505143 A	09-02-2006
		JP 2010263238 A	18-11-2010
		KR 20050084640 A	26-08-2005
		US 2004085173 A1	06-05-2004
		WO 2004042754 A1	21-05-2004
EP 0913841 A1	06-05-1999	NONE	
EP 0283354 A1	21-09-1988	DE 3880718 D1	09-06-1993
		DE 3880718 T2	05-01-1994
		EP 0283354 A1	21-09-1988
		FR 2622344 A2	28-04-1989
		JP 2625477 B2	02-07-1997
		JP S6477109 A	23-03-1989
		US 4843362 A	27-06-1989
EP 2498266 A2	12-09-2012	CN 102682952 A	19-09-2012
		EP 2498266 A2	12-09-2012
		JP 2012186405 A	27-09-2012
		US 2012229118 A1	13-09-2012
EP 2518740 A1	31-10-2012	CN 102667977 A	12-09-2012
		EP 2518740 A1	31-10-2012
		KR 20120098921 A	05-09-2012
		US 2012326830 A1	27-12-2012
		WO 2011077694 A1	30-06-2011
CN 202258665 U	30-05-2012	NONE	

EPC FORM P0459

For more details about this annex : see Official Journal of the European Patent Office, No. 12/82