

(19)
(12)

(KR)
(B1)

(51) 。 Int. Cl. ⁶
E03F 5/046

(45)
(11)
(24)

2002 03 18
10 - 0329377
2002 03 07

(21) 10 - 1999 - 0021439
(22) 1999 06 09

(65) 1999 - 0068666
(43) 1999 09 06

(73)

25 - 1

(72)

1 153 - 6

402

(74)

:

(54)

가

,

,

,

가

,

.

1

1

2 1 .

, 가

, 가

1 , 5 , 2 1 , 3 1 , 4 3 A - A

1 5 (100) (200) (10) (100) 가
 (100) (20) (22) (22) (20)

(24)

(10) (20) L , 4 (10) (100) (200) (10) (20)
 , 가 (20)가 (100) (200) (24) (10)

0) (20) (22) 2 (X) (Y)
 (100)가 (100)

Z) 6 7 (20) (22)가 (X) ()
 (100)가 () (100)

26 (20) (22)가 (chamfer) (26)
 ()

28 (20) (24) 가 가

(20) (22) (26) , 가 (30)
 가 (30) 가

(22)

(22) (24) 100/1 - 100/4

(20)

(20)

(22)

(22)
(24)

(X)

(Y)

3.

1

(20)

(22)

(X)

(Z)

5.

1

(20)
(22)

가

(22)

(26)

가

(30)

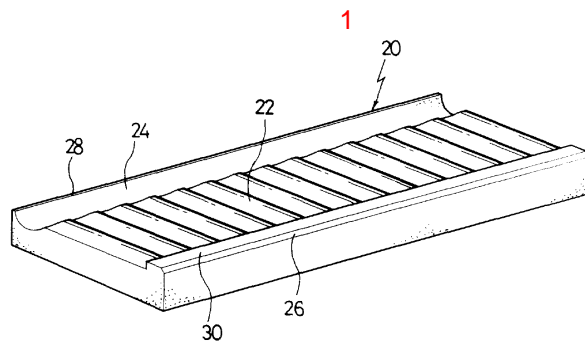

2

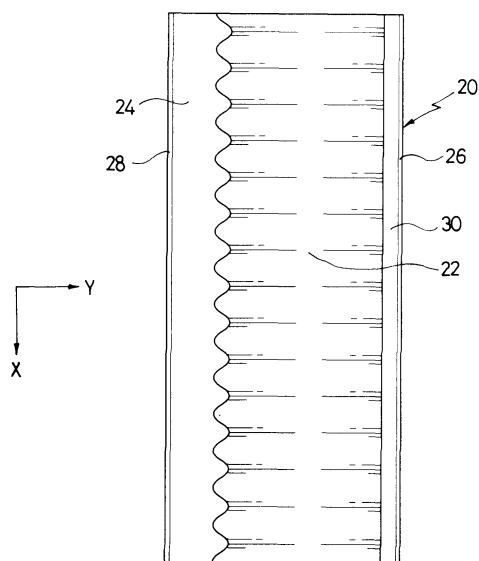

3

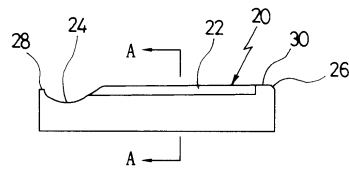

4

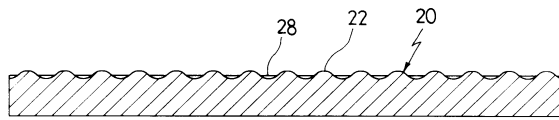

5

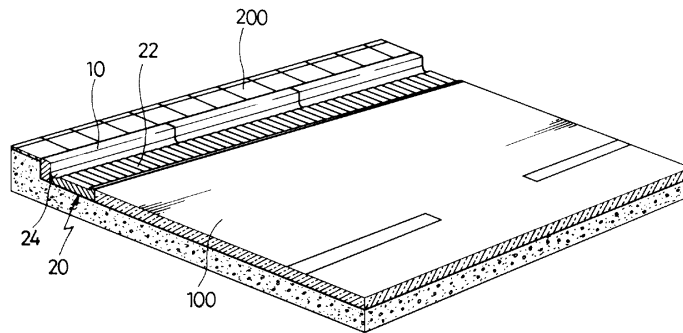

6

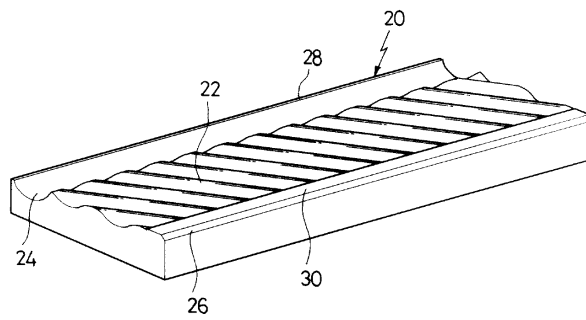

7

