



US00D329466S

United States Patent [19]
Martin

[11] **Patent Number: Des. 329,466**

[45] **Date of Patent: ** Sep. 15, 1992**

[54] **SUPPORT MODULE FOR MOBILE
ADVERTISING DISPLAYS FOR SPORTING
ARENAS**

[75] **Inventor: D. Jose M. G. Martin, Madrid, Spain**

[73] **Assignee: Dorna Sports Promotion, Inc., New
York, N.Y.**

[**] **Term: 14 Years**

[21] **Appl. No.: 541,245**

[22] **Filed: Jun. 19, 1990**

[30] **Foreign Application Priority Data**

Dec. 19, 1989 [ES] Spain 120.732

[52] **U.S. Cl. D20/10**

[58] **Field of Search D20/10, 19, 39, 40,
D20/41, 42, 43; 40/429, 430, 427, 431, 411, 414,
584, 606, 613, 614, 615**

[56] **References Cited**

U.S. PATENT DOCUMENTS

| | | | |
|-----------|---------|-------------------|--------|
| 1,374,921 | 4/1921 | Houston | 40/430 |
| 2,211,353 | 8/1940 | Solkover | 40/429 |
| 2,252,124 | 8/1941 | Hanson | 40/429 |
| 2,963,807 | 12/1960 | Rolph et al. | D20/10 |
| 3,475,845 | 11/1969 | Estvan, Jr. | 40/430 |

Primary Examiner—Wallace R. Burke
Assistant Examiner—Marcus Jackson
Attorney, Agent, or Firm—Helfgott & Karas

[57] **CLAIM**

The ornamental design for a support module for mobile advertising displays for sporting arenas, as shown and described.

DESCRIPTION

FIG. 1 is a front perspective view of a support module for mobile advertising displays for sporting arenas showing my new design; FIG. 2 is a rear perspective view thereof; and, FIG. 3 is a top perspective view thereof, with the rear panel shown in open condition.

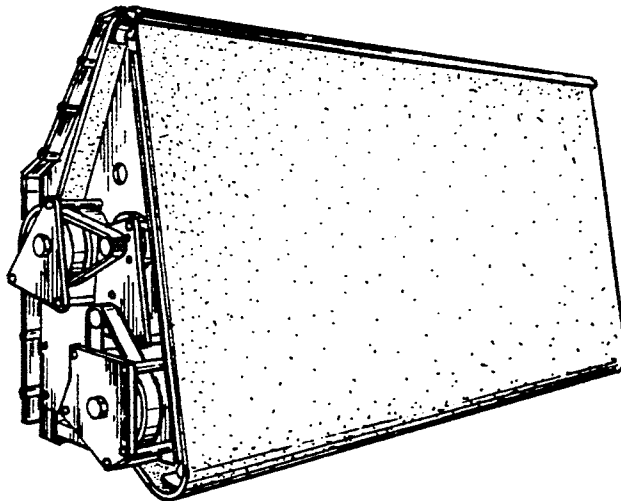

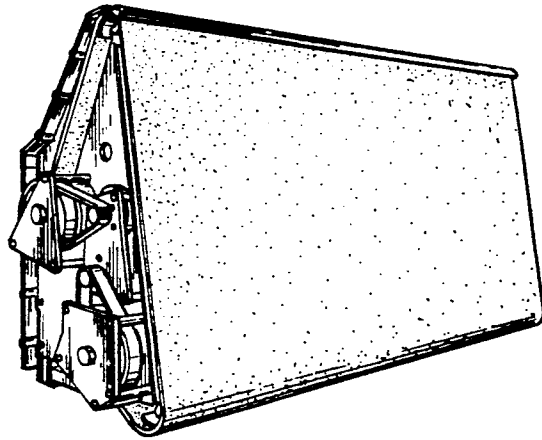

Fig. 1.

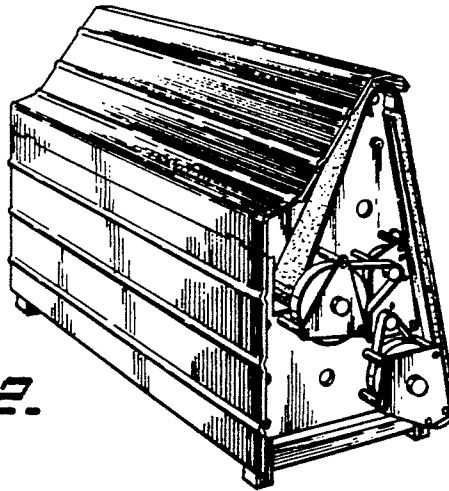

Fig. 2.

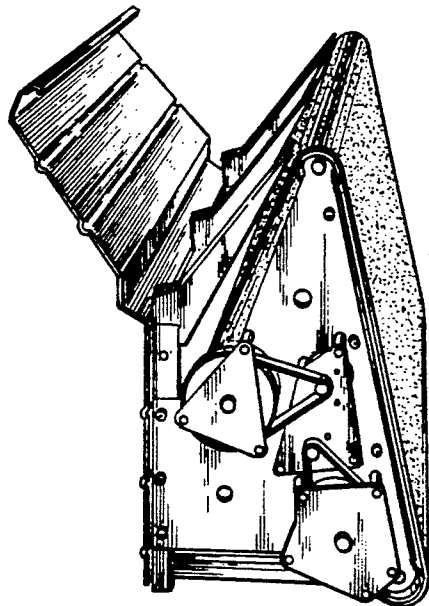

Fig. 3.