

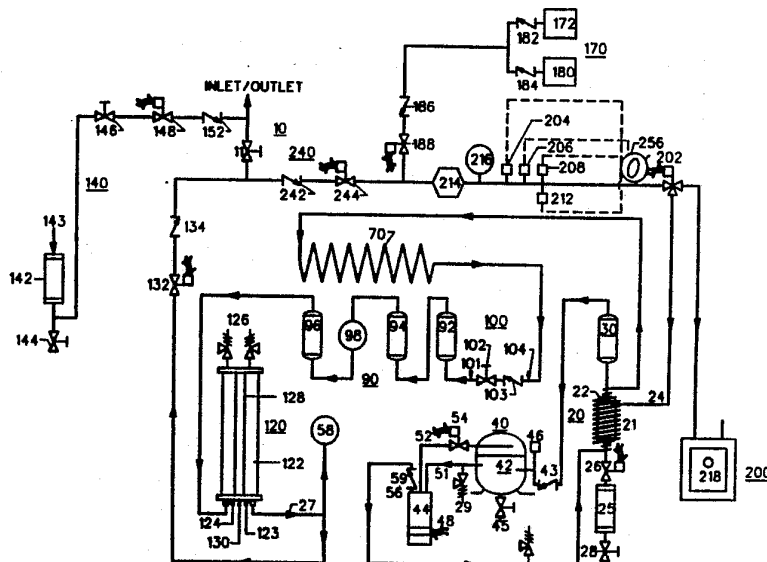

## INTERNATIONAL APPLICATION PUBLISHED UNDER THE PATENT COOPERATION TREATY (PCT)

<p>(51) International Patent Classification <sup>5</sup> : <b>F25B 45/00</b></p>	<p><b>A2</b></p>	<p>(11) International Publication Number: <b>WO 92/16802</b> (43) International Publication Date: 1 October 1992 (01.10.92)</p>
<p>(21) International Application Number: PCT/US92/01485 (22) International Filing Date: 25 February 1992 (25.02.92) (30) Priority data: 667,695 11 March 1991 (11.03.91) US (71) Applicant: ASHLAND OIL, INC. [US/US]; P.O. Box 391, BL2, Ashland, KY 41114 (US). (72) Inventor: YOUNG, Robert, E. ; 2048 Fallon Drive, Lexington, KY 40504 (US). (74) Agents: WILLSON, Richard, C., Jr.; P.O. Box 391, BL2, Ashland, KY 41114 (US) et al.</p>		<p>(81) Designated States: AT (European patent), AU, BB, BE (European patent), BF (OAPI patent), BG, BJ (OAPI patent), BR, CA, CF (OAPI patent), CG (OAPI patent), CH (European patent), CI (OAPI patent), CM (OAPI patent), CS, DE (European patent), DK, DK (European patent), ES (European patent), FI, FR (European patent), GA (OAPI patent), GB (European patent), GN (OAPI patent), GR (European patent), HU, IT (European patent), JP, KP, KR, LK, LU (European patent), MC (European patent), MG, ML (OAPI patent), MN, MR (OAPI patent), MW, NL (European patent), NO, PL, RO, RU, SD, SE (European patent), SN (OAPI patent), TD (OAPI patent), TG (OAPI patent).</p> <p><b>Published</b> <i>Without international search report and to be republished upon receipt of that report.</i></p>

## (54) Title: REFRIGERATION RECOVERY AND PURIFICATION



## (57) Abstract

Refrigerant recovery and purification system optionally capable of drawing a nearly full vacuum on the system to be evacuated and having multi-port valve means for setting to different configurations for different refrigerant processing cycles; e.g., evacuation, deep vacuum, recovery, purification cycle, refrigerant charging, and oil charging, etc. Virgin refrigerant can be inputted from commercial cylinders or from refrigerant cans via a can manifold. Major components comprise: inlet/outlet means (10), suction accumulator means (20), low-side purifying means (filter dryer) (30), compressor means (40), secondary coil means (70), purifying means (highside) (90), pump-down manifold means (100), storage means (120), oil injection means (140), virgin refrigerant supply means (170) and (180), vacuum pump means (200), and circulation control means (240).

**FOR THE PURPOSES OF INFORMATION ONLY**

Codes used to identify States party to the PCT on the front pages of pamphlets publishing international applications under the PCT.

AT	Austria	FI	Finland	ML	Mali
AU	Australia	FR	France	MN	Mongolia
BB	Barbados	GA	Gabon	MR	Mauritania
BE	Belgium	GB	United Kingdom	MW	Malawi
BF	Burkina Faso	GN	Guinea	NL	Netherlands
BG	Bulgaria	GR	Greece	NO	Norway
BJ	Benin	HU	Hungary	PL	Poland
BR	Brazil	IE	Ireland	RO	Romania
CA	Canada	IT	Italy	RU	Russian Federation
CF	Central African Republic	JP	Japan	SD	Sudan
CG	Congo	KP	Democratic People's Republic of Korea	SE	Sweden
CH	Switzerland	KR	Republic of Korea	SN	Senegal
CI	Côte d'Ivoire	LI	Liechtenstein	SU	Soviet Union
CM	Cameroon	LK	Sri Lanka	TD	Chad
CS	Czechoslovakia	LU	Luxembourg	TG	Togo
DE	Germany	MC	Monaco	US	United States of America
DK	Denmark	MG	Madagascar		
ES	Spain				

1  
2  
3  
4  
5  
6  
7  
8  
9  
10  
11  
12  
13  
14  
15  
16  
17  
18  
19  
20  
21  
22  
23  
24  
25  
26  
27  
28  
29  
30  
31  
32  
33  
34  
35  
36  
37  
38  
39  
40

1

## REFRIGERATION RECOVERY AND PURIFICATION

### Cross Reference to Related Applications

Cross references to related applications, USSN 394,594, filed 08/16/89 (attorney docket 6349AUS), USSN 371,785, filed 06/27/89 (attorney docket 6346AUS) USSN 600,367, filed 10/19/90 (attorney docket 6346MUS), USSN 538,639, filed 06/13/90 (attorney docket 6349MUS), and USSN 601,838, filed 10/18/90 (attorney docket 6349NUS) relates to the general field of the present invention.

### Background of Invention

#### I. Field of the Invention

The present invention relates to the field of recovery of refrigerants from refrigeration systems which are to be repaired after they are evacuated of refrigerant. These devices are generally classified in U. S. Patent Office Class 62, subclasses 126, 149, 292, 471, 513, and Class 165, subclass 163.

#### II. Description of the Prior Art

Attempts have been made to produce an effective refrigerant recovery and/or disposal, purification and recharging system. Issued U. S. Patents representative of such known systems are: U. S. 3,232,070; 4,285,206; 4,363,222; 4,441,330; 4,476,688; 4,539,817; 4,554,792; 4,646,527; 4,766,733; 4,809,520; and 4,852,769.

1  
2  
3  
4  
5  
6  
7  
8  
9  
10  
11  
12  
13  
14  
15  
16  
17  
18  
19  
20  
21  
22  
23  
24  
25  
26  
27  
28  
29  
30  
31  
32  
33  
34  
35  
36  
37  
38  
39  
40

2

None of the prior art references provide the combination of features obtained by the present invention with its ability to recover, purify, recharge, and evacuate, and accept sources of purchased refrigerant, as well.

### Summary of the Invention

#### I. General Statement of the Invention

According to the present invention, a compressor means 40 and/or a vacuum pump means 200 withdraw refrigerant from a system to be evacuated for repair or other reasons, and discharge it with suitable heat exchange 20/22 to a liquefaction unit which supplies liquid refrigerant to a purification unit 30 & 90, which in turn feeds a refrigerant recharging system 120, 132, 11 capable of receiving refrigerant from storage means 120 or from new containers of newly purchased refrigerant 170. The process being capable of being controlled by valving which alternately switches 256 from the evacuating, purification and admitting of new refrigerant, or optional vacuum pump means 200 for even greater recovery of refrigerant from the system being evacuated.

1  
2  
3  
4  
5  
6  
7  
8  
9  
10  
11  
12  
13  
14  
15  
16  
17  
18  
19  
20  
21  
22  
23  
24  
25  
26  
27  
28  
29  
30  
31  
32  
33  
34  
35  
36  
37  
38  
39  
40

3

## II. Utility of the Invention

The invention is valuable from both an economic and an ecological standpoint because it recovers refrigerant which is not only valuable, but which has recently been found to deleteriously affect the ozone layer of the earth. The invention can be used for evacuating a wide variety of refrigeration systems, including residential heat pumps, room and central unit air conditioners, refrigerators and freezers, and is especially preferred for evacuation of automotive air conditioning systems.

### **Brief Description of the Drawings**

Figure 1 is a schematic diagram of the system of the invention.

Figure 2a is a detail of a distiller.

Figure 2b is a detail of the storage cylinder useful with the invention.

Figure 3 is a isometric view of the front and one side of an assembled unit according to the invention, showing the gauges, sight glass, electrical controls, and oil addition gauge. Note all expendable parts; e.g., filter dryers are readily accessible by removing the back panel (not shown) without interfering with other components of the system.

Figure 4 is a detail of the can-piercing manifold useful as an optional component of the invention.

Figure 5 is a schematic electric circuit diagram.

**Description of the Preferred Embodiments**

Referring to Figure 1, the principal components of the preferred system of the invention consist of inlet/outlet means 10, suction accumulator means 20, low-side purifying means 30, compressor means 40, secondary coil means 70, purifying means (highside) 90, pump-down manifold means 100, storage means 120, oil injection means 140, virgin refrigerant supply means 170 and 180, vacuum pump means 200, and circulation control means 240.

More specifically referring to the individual components in Figure 1, inlet/outlet means 10 is connected to suction accumulator means 20, which includes canister means 21 in heat exchange relationship to external coil 22, and side inlet 24 and an oil drain system comprising electric oil dump valve 26 connected to the bottom of canister means 21 and feeding into used oil reservoir 25, which can be drained through valved outlet 28. The top outlet of canister means 21 feeds compressor means 40 through low side purifying means 30. Compressor means 40, includes oil check valve on suction 43 and oil separator on return 44 with heater 48, which feeds oil back to compressor 42 through solenoid valve 54. Oil separator on return 44 feeds through check valve 59 into hot gas external coil 22, as mentioned above. Cooled vapor from external coil 22 is conducted to secondary coil (condenser) means 70 where it is liquified and then passed through highside purifying means 90, which consists of various check valves and manual valves, pump-down manifold 100 and purification filter dryers. Filter dryer 30 (preferably SPORLAN Model 403), filter dryer 92, and filter dryer 94 (preferably both SPORLAN Model 313) with moisture indicator 98 (a moisture indicating sight glass is preferred)

1  
2  
3  
4  
5  
6  
7  
8  
9  
10  
11  
12  
13  
14  
15  
16  
17  
18  
19  
20  
21  
22  
23  
24  
25  
26  
27  
28  
29  
30  
31  
32  
33  
34  
35  
36  
37  
38  
39  
40

indicating the degree of dryness of the refrigerant, followed by a fourth filter dryer 96 (SPORLAN Model 403). The liquid refrigerant then flows into storage means 120 which includes 10-pound cylinder 122, which is fitted with gauge glass 128, and protected by safety/vent valves 126, and which is equipped with float switch 124 and heaters 130, and low-side purifying means filter dryer 30 (SPORLAN Model 403).

The contents of the 10-pound cylinder 122 can be discharged from storage means 120 via line 27, solenoid valve 132 and check valve 134 into inlet/outlet means 10 to recharge or to flow into a storage cylinder (now shown) if the refrigerant is not needed immediately. When recharging units, oil injection means 140 can be used to add oil to the system being charged. Oil injection means 140 consists of reservoir 142, drain valve 144, hand valve 146, solenoid valve 148, check valve 152 and fill part 143 connected to a standard refrigeration serviceman's gauge (not shown).

As an additional alternative, the contents can be discharged through solenoid valve 132, check valve 134 with hand valve 11 closed so that the refrigerant continues through check valve 242, solenoid valve 244 which is open and through debris screen 214, gauge 216, pressure switch-75 psig 204, pressure switch-15 psig 206, pressure switch-4"Hg 212 pressure switch-4 psig 208, through 3-way solenoid valve 202 which directs the flow back through line side inlet 24 into canister means 21 and then back to compressor means 40, to recirculate for additional purification until moisture indicator 98 shows sufficient dryness.

New or previously stored refrigerant can be added through virgin refrigerant supply means 170 which includes can-tapper

1  
2  
3  
4  
5  
6  
7  
8  
9  
10  
11  
12  
13  
14  
15  
16  
17  
18  
19  
20  
21  
22  
23  
24  
25  
26  
27  
28  
29  
30  
31  
32  
33  
34  
35  
36  
37  
38  
39  
40

6

(detail from U. S. Patent 4,852,769 to Robertson), 30-pound cylinder connection 180, check valve 186, and solenoid valve 188 with 3-way solenoid valve 202 in the position to feed through its side outlet into canister means 21 and then through compressor means 40, external coil 22, secondary coil means 70, highside purifying means 90 and into storage means 120.

With solenoid valve 132 closed, and solenoid valve 244 open, and 3-way solenoid valve 202 set for straight-through flow, vacuum pump means 200 can be used to pull a strong vacuum on the unit which is to be evacuated. This extracts additional moisture which can be vented to the air and/or additional refrigerant which can be (through piping not shown) also recovered and liquified in secondary coil means 70 for reuse.

To maintain oil supply in the compressor, hot gas returns through oil separator 44 which has a ball float switch which opens oil separator 44 to return oil to compressor means solenoid 54 is opened in response to pressure switch 56 sensing 15 psig or more.

To change oil, compressor oil can be drained by opening hand drain valve 45 and new oil added through compressor oil adding port 46.

1  
2  
3  
4  
5  
6  
7  
8  
9  
10  
11  
12  
13  
14  
15  
16  
17  
18  
19  
20  
21  
22  
23  
24  
25  
26  
27  
28  
29  
30  
31  
32  
33  
34  
35  
36  
37  
38  
39  
40

The invention will be better understood by tracing several of the alternatives:

#### Simple Evacuation of a System

With solenoid valve 244 open and 3-way solenoid valve 202 set for right-angle flow, refrigerant flows from the system connected to inlet/outlet means 10 through a refrigeration serviceman's gauge set (not shown) into canister means 21 where it is evaporated with vapor moving through low side purifying means 30 and oil check valve on suction into compressor means 40, with oil being recovered in oil separator on return 44 and the hot gas is being used to heat canister means 21 by means of external coil 22 after which the hot gases are cooled in secondary coil means 70 and purified in highside purifier means 90, and moved to storage means 120.

#### Deep Evacuation

After pressure switch-4"Hg 212 senses a vacuum, 3-way solenoid valve 202 is actuated to connect vacuum pump means 200 to the system being evacuated until manually shut off when a sufficiently deep vacuum is achieved. Hand valve 11 can then be closed.

#### Purification Cycle

Three-way solenoid valve 202 can again be set to right-angle flow by turning rotary control switch 256 and the refrigerant from cylinder 122 can be cycled through compressor means 40, having external coil 22, secondary coil means 70, highside purifying means 90, and back to storage means 120.

1  
2  
3  
4  
5  
6  
7  
8  
9  
10  
11  
12  
13  
14  
15  
16  
17  
18  
19  
20  
21  
22  
23  
24  
25  
26  
27  
28  
29  
30  
31  
32  
33  
34  
35  
36  
37  
38  
39  
40

This can be continued until moisture indicator shows a satisfactory moisture level, so that the refrigerant is now suitable for use in recharging other systems. Preferably, rotary control switch 256 is a 3-port valve with the opening and closing configurations for the various ports controlled by multi-position switch 256 which can be set for any of the various cycles as described herein; e.g., refrigerant recovery, purification, oil recovery, deep vacuum, refrigerant charging, oil addition, etc. Multi-position switch 256 can also control the opening and closing of the various other solenoid valves in the system. The switch positions are labeled with the short-names of the cycles so that, in operation, it is merely necessary to turn the switch to the desired cycle, much as one would set an oven on an electric range.

#### Recharging

A refrigeration system for recharging can be connected through the above serviceman's gauge set (not shown) and valve 11 opened. Vacuum pump means 200 can be used to fully vacuum if necessary. The system can then be recharged from 20-pound cylinder by opening hand valve 11, pressing charging button 13 to open solenoid valve 132. Oil can additionally be added from reservoir by opening hand valve 11 and solenoid valve 148 to measure the desired quantity of oil from sight glass 142 which can be refilled through inlet 143. Refrigerant can be accurately measured by gauge glass 128 which corrects temperature variations and dispenses a pre-measured volume. Alternatively, a 10-pound refrigerant cylinder can be mounted on a load cell so that the refrigerant recharge is measured by weight.

#### Recharging with Virgin Refrigerant

1  
2  
3  
4  
5  
6  
7  
8  
9  
10  
11  
12  
13  
14  
15  
16  
17  
18  
19  
20  
21  
22  
23  
24  
25  
26  
27  
28  
29  
30  
31  
32  
33  
34  
35  
36  
37  
38  
39  
40

Solenoid valve 132 and 3-way solenoid valve 202 can both be closed, and hand valve 11 and solenoid valve 244 both opened so the refrigerant flows from virgin refrigerant supply means 170 through 11 which is opened and out through the above refrigerant serviceman's gauge set into the new system. Oil can be added from oil injection means 140 as described previously under Recharging .

#### Can Manifold

Figure 4 shows a manifold 172 suitable for tapping into refrigerant cans, a convenient source of virgin refrigerant. Piercing and sealing devices 172 are preferable according to U. S. Patent 4,852,769 to Robertson. Other alternative sources of refrigerant are storage means 120 cylinders filled with recovered and purified refrigerant from the present system, larger disposable containers or refillable refrigerant cylinders and connected to source inlet 180.

#### Pump-down Cycle for Changing Filter Dryers

Service port 101 and 104 are preferably schrader valves and can be used to remove all refrigerant from the system prior to replacing any of filter dryers 92, 94, 96 or 30. Port 104 is connected by hose to an external storage cylinder and connect port 101 by hose to service outlet 10. Then compressor 40 can pump all refrigerant into the storage cylinder.

1  
2  
3  
4  
5  
6  
7  
8  
9  
10  
11  
12  
13  
14  
15  
16  
17  
18  
19  
20  
21  
22  
23  
24  
25  
26  
27  
28  
29  
30  
31  
32  
33  
34  
35  
36  
37  
38  
39  
40

10

### Modifications

Specific compositions, methods, or embodiments discussed are intended to be only illustrative of the invention disclosed by this specification. Variation on these compositions, methods, or embodiments are readily apparent to a person of skill in the art based upon the teachings of this specification and are therefore intended to be included as part of the inventions disclosed herein.

Reference to documents made in the specification is intended to result in such patents or literature being expressly incorporated herein by reference including any patents or other literature references cited within such documents.

What is claimed is:

**CLAIMS**

1  
2  
3  
4  
5 1. An improved apparatus for the recovery, purification  
6 and recharging of refrigerant from a refrigeration system, said  
7 system comprising in combination:  
8

- 9 (a) an inlet/outlet means connected to  
10 (b) a suction accumulation means connected to  
11 (c) a compressor means connected to  
12 (d) a cooling coil means connected to  
13 (e) a purifying means (highside) connected to  
14 (f) a storage means adapted for recharging said  
15 system with a measured charge of refrigerant.  
16  
17

18  
19  
20 2. An apparatus according to Claim 1 additionally  
21 comprising:  
22

- 23 (g) secondary coil means 70 connected to  
24 receive and condense at least a portion of  
25 refrigerant from said cooling coil means.  
26  
27

28 3. An apparatus according to Claim 1 additionally  
29 comprising:  
30

- 31 (h) vacuum pump means having 3-way solenoid  
32 valve alternately connecting said inlet/outlet  
33 means to said vacuum pump means to  
34 communicate with said refrigerant system or  
35 to said suction accumulator means;  
36  
37

- 38 (i) first sensing means to start said vacuum  
39 pump means in response to a first internal  
40

1  
2  
3  
4  
5  
6  
7  
8  
9  
10  
11  
12  
13  
14  
15  
16  
17  
18  
19  
20  
21  
22  
23  
24  
25  
26  
27  
28  
29  
30  
31  
32  
33  
34  
35  
36  
37  
38  
39  
40

12

pressure within said inlet/outlet means substantially equal to atmospheric pressure; and

(j) second pressure sensing means to stop said vacuum pump means at a substantially lower pressure in said inlet/outlet means.

4. An apparatus according to Claim 1 additionally comprising:

(k) circulation control for causing refrigerant to circulate from said storage means back through said suction accumulator and said secondary coil and said purifying (highside) to return to said storage.

5. An apparatus according to Claim 1 wherein said suction accumulation means comprises a canister in heat exchange relationship to external coil, said canister having side inlet and oil collection and said external coil having inlet to cooling coil from storage means and being connected directly or indirectly to secondary coil on its outlet and to compressor on its inlet.

6. An apparatus according to Claim 1 additionally comprising all drain means for draining oil from a point near the bottom of said suction accumulator means.

7. An apparatus according to Claim 1 additionally comprising oil charging means for measuring a quantity of oil out through said inlet/outlet means to recharge said refrigeration system with a measured charge of oil.

1  
2  
3  
4  
5  
6  
7  
8  
9  
10  
11  
12  
13  
14  
15  
16  
17  
18  
19  
20  
21  
22  
23  
24  
25  
26  
27  
28  
29  
30  
31  
32  
33  
34  
35  
36  
37  
38  
39  
40

8. An apparatus according to Claim 1 additionally comprising a multi-position switch controlling a plurality of solenoid valves adapted to configure the apparatus to various cycles in the recovery, evacuation and recharging of said refrigeration system.

9. A process according to Claim 8 wherein at least one of said solenoid valves is a 3-way valve directing flow from said inlet/outlet means to said suction accumulator (storage) means or alternatively to a vacuum pump means for evacuating said refrigeration system.

10. An apparatus according to Claim 1 additionally comprising means for adding virgin refrigerant to said storage means 122.

11. Additionally comprising a manifold for discharging the contents of two or more hermetically sealed cans of refrigerant into said storage means.



2/7

FIG. 2a

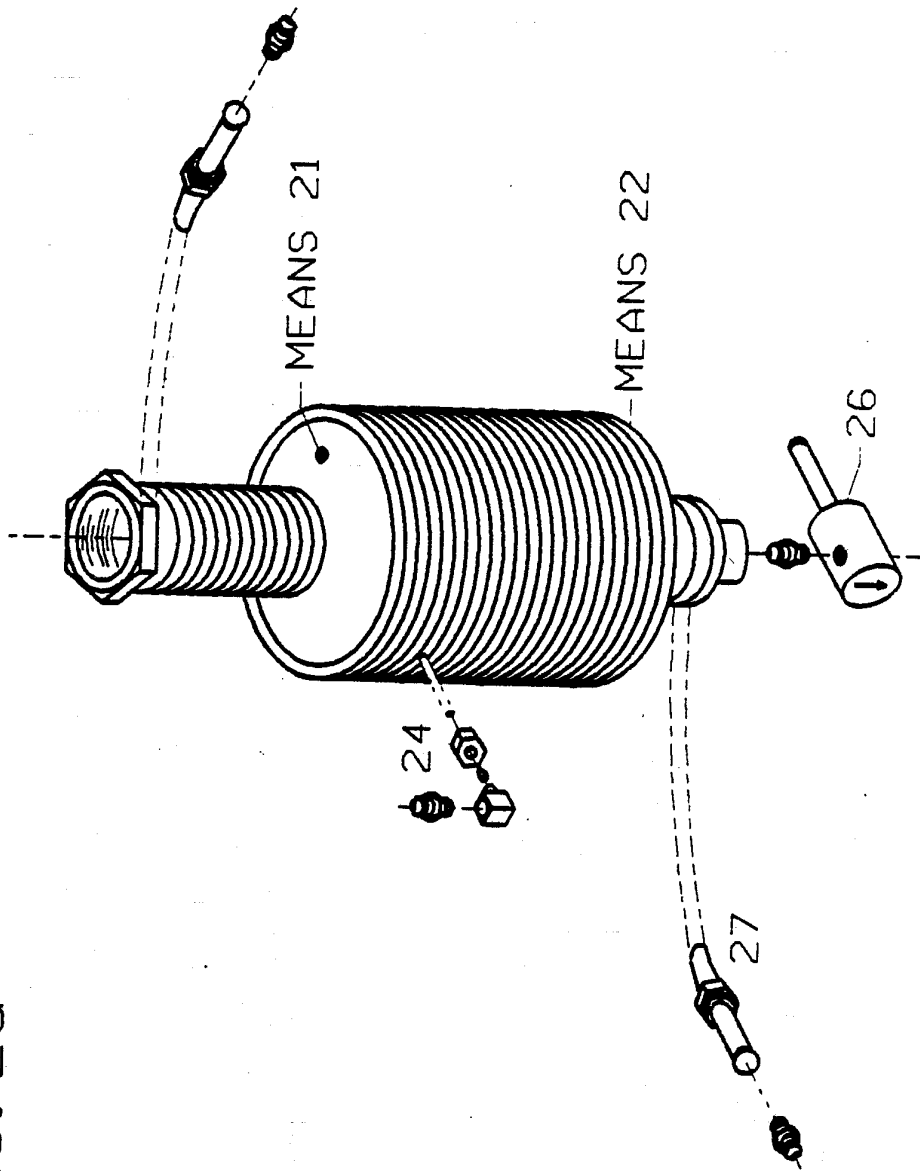

3/7

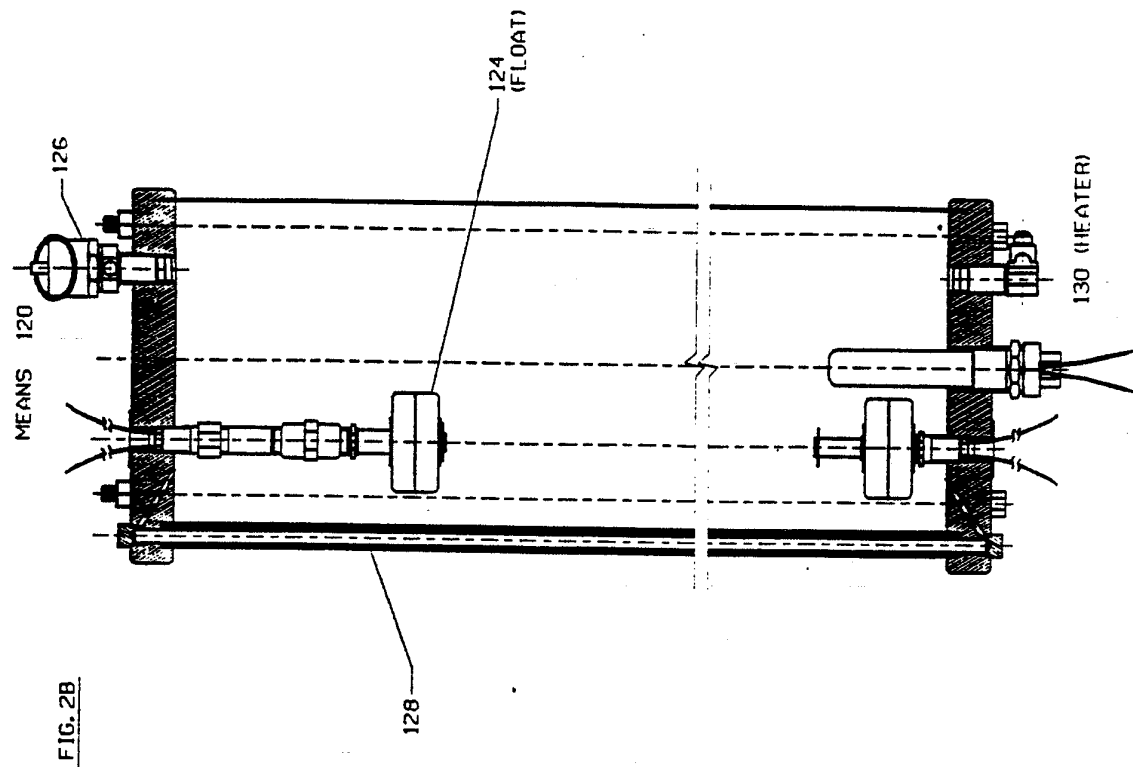
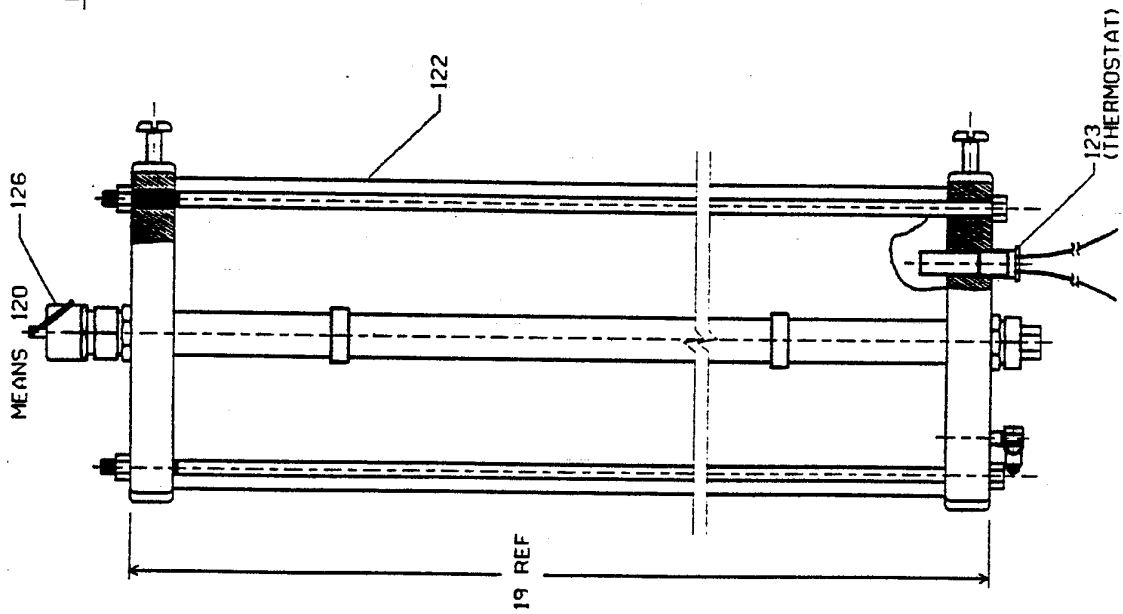

FIG. 2B



19 REF

4/7

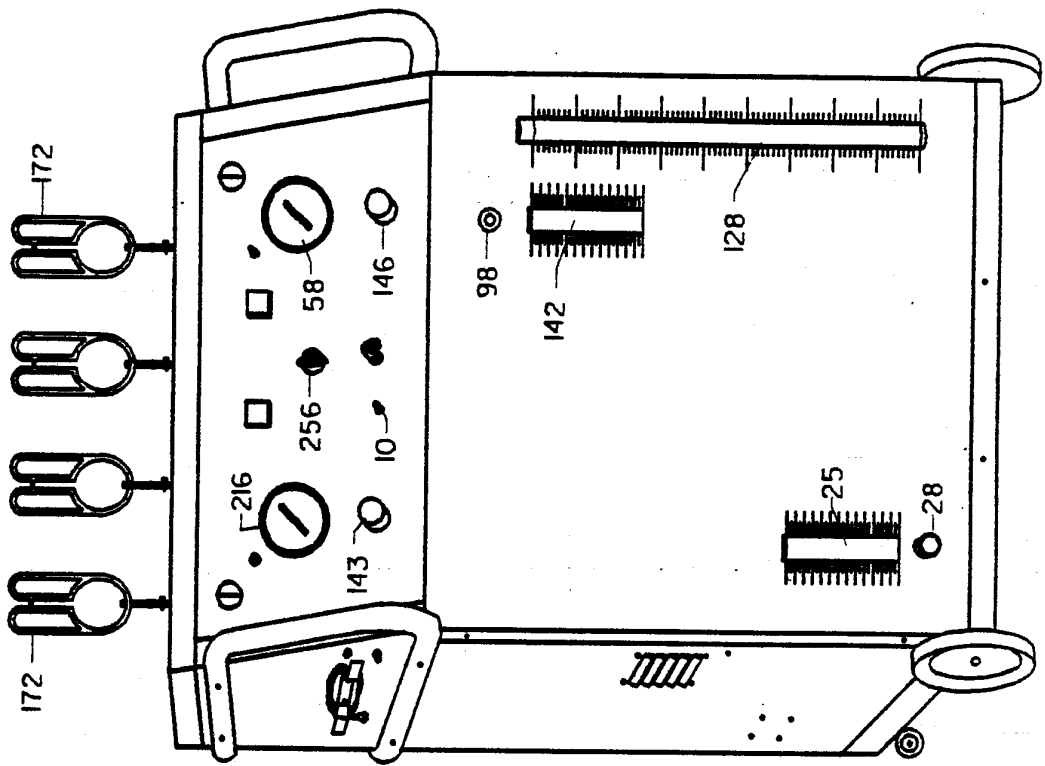
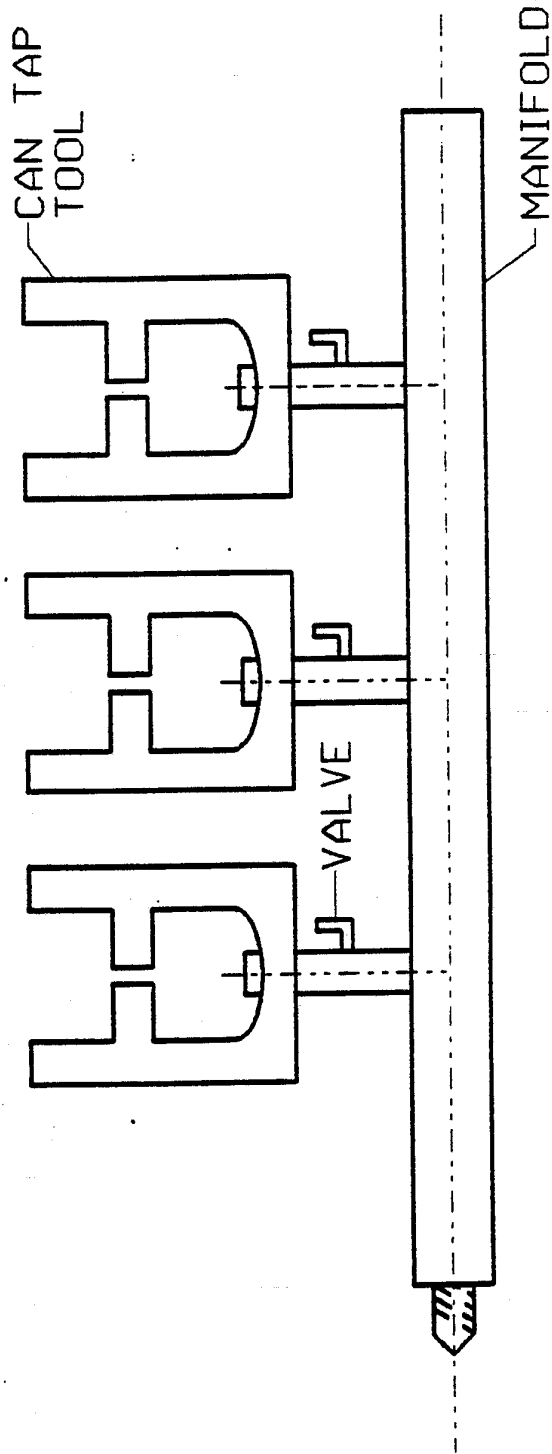

FIG. 3

5/7

FIG. 4



6/7

FIG. 5A

