

(19) World Intellectual Property Organization
International Bureau



(43) International Publication Date
16 February 2012 (16.02.2012)

(10) International Publication Number
WO 2012/020441 A2

(51) International Patent Classification:
B63H 9/06 (2006.01)

(21) International Application Number:
PCT/IT2011/000292

(22) International Filing Date:
9 August 2011 (09.08.2011)

(25) Filing Language: Italian

(26) Publication Language: English

(30) Priority Data:
RM2010A000450 12 August 2010 (12.08.2010) IT

(71) Applicant (for all designated States except US):
NAUTIGEST S.R.L. [IT/IT]; Via S. Marino, 12, I-00198
Roma, RM (IT).

(72) Inventor; and

(75) Inventor/Applicant (for US only): **CARDONI, Giorgio**
[IT/IT]; Nautigest S.r.l., Via S. Marino, 12, I-00198
Roma, RM (IT).

(74) Agent: **BANCHETTI, Marina**; Barzano' & Zanardo
Roma S.p.A., Via Piemonte, 26, I-00187 Roma (IT).

(81) Designated States (unless otherwise indicated, for every
kind of national protection available): AE, AG, AL, AM,

AO, AT, AU, AZ, BA, BB, BG, BH, BR, BW, BY, BZ,
CA, CH, CL, CN, CO, CR, CU, CZ, DE, DK, DM, DO,
DZ, EC, EE, EG, ES, FI, GB, GD, GE, GH, GM, GT,
HN, HR, HU, ID, IL, IN, IS, JP, KE, KG, KM, KN, KP,
KR, KZ, LA, LC, LK, LR, LS, LT, LU, LY, MA, MD,
ME, MG, MK, MN, MW, MX, MY, MZ, NA, NG, NI,
NO, NZ, OM, PE, PG, PH, PL, PT, QA, RO, RS, RU,
SC, SD, SE, SG, SK, SL, SM, ST, SV, SY, TH, TJ, TM,
TN, TR, TT, TZ, UA, UG, US, UZ, VC, VN, ZA, ZM,
ZW.

(84) Designated States (unless otherwise indicated, for every
kind of regional protection available): ARIPO (BW, GH,
GM, KE, LR, LS, MW, MZ, NA, SD, SL, SZ, TZ, UG,
ZM, ZW), Eurasian (AM, AZ, BY, KG, KZ, MD, RU, TJ,
TM), European (AL, AT, BE, BG, CH, CY, CZ, DE, DK,
EE, ES, FI, FR, GB, GR, HR, HU, IE, IS, IT, LT, LU,
LV, MC, MK, MT, NL, NO, PL, PT, RO, RS, SE, SI, SK,
SM, TR), OAPI (BF, BJ, CF, CG, CI, CM, GA, GN, GQ,
GW, ML, MR, NE, SN, TD, TG).

Published:

— without international search report and to be republished
upon receipt of that report (Rule 48.2(g))



WO 2012/020441 A2

(54) Title: IMPROVED AIRFOIL SAIL STRUCTURE, OR "WINGSAIL"

(57) Abstract: The invention relates to an airfoil sail structure (1) or "wingsail" mounted on a mast (7) of a boat (2), said structure (1) being characterized in that on said mast (7) are placed, from the bottom to the top, a base element (8), at least one intermediate modular element (4), and an upper modular element (5), said modular elements (4, 5, 8) having a rigid coupling structure with said mast (7) bow of the same, said at least one intermediate (4) and upper (5) modular element having a flexible structure extending from said mast (7) to aft, on said modular elements (4, 5, 8) being wrapped externally a single sail (3), said upper modular element being coupled to halyards (20) to hoist the sail (3) of the structure (1).

IMPROVED AIRFOIL SAIL STRUCTURE, OR "WINGSAIL"

The present invention relates to an improved airfoil sail structure, or "wingsail".

5 More specifically, the present invention relates to a sail of the above kind that can remarkably improve performances of a wind powered means, making it easier rigging the same and improving controlling the boat.

10 The specification will be addressed in the following to the use of said sail for different kind of sailing boats, particularly small boats or derive, cruising yachts and racing boats, regardless their dimensions, mono- or multi- hull (on which the inventive wingsail can be supported by shroud), but the same inventive solution can be provided on any other means without departing or limiting the scope of the invention.

15 Further, present specification refers to the system per sé, since designing choices will set dimensions, materials, NACA profiles, lengthening and other particulars that will be only shortly mentioned in the present specification.

20 As it is well known, wingsails are the new frontier of sailing search and development, as it is well evident from Oracle multihull used during last 33rd edition of America's Cup.

The above technology is inspired to similarity between boats and airplanes, i.e. the use of the wind as the lifting force.

25 Main advantage of wings is due to their asymmetric and with high thickness section, permitting obliging upper laminar flow to a violent acceleration, by which a lower pressure zone is created, "sucking" airplane upward.

Instead, sails are characterized by a low thickness, creating a very low speed difference between the air flows along the two sail sides.

30 Thus, a "wingsail" is much more efficient with respect to a standard sail since it: has a higher lifting, has a lower aerodynamic resistance (dragging), requires a lower leading edge with respect to the wind, is less subjected to wind variations, and it has resulting forces directed toward the running direction, thus reducing heeling and leeway.

35 Main drawbacks of wingsails particularly are designing complexity and operation, high costs, higher weight with respect to a traditional arrangement, and difficulties to control and adjust the same.

Furthermore, wingsails are rigid, as the one used for last edition of America's Cup, and thus difficult to manage when boat is stopped or not used, being it necessary dismounting the same.

Obviously, aerodynamic is one of the most important aspects when properly designing a wingsail, since having a variable profile is very important.

While asymmetric profile for an airplane is a fixed profile, since depression rata, wingsail must invert its profile so as to obtain an increase of laminar flow speed always and only in correspondence of lee part.

Furthermore, it is necessary taking care of aspects concerning aerodynamic, such as: realizing a more efficient profile, obtaining lower aerodynamic resistance (dragging), less turbulence areas (windage) and induced resistance.

Making reference to wingsail structure, another crucial sector is the choice of materials.

The above choice is important also for traditional sails, but, in this case, due to higher air flow speed, it is more important. In fact, in wingsails, a small imperfection of surface can create a large turbulence; or a not sufficient rigidity of the upper end of the wing can amplify risks deriving from vortexes, which are typical in this part of the sail.

Rigid wingsail have been developed in the past, all characterized by different drawbacks.

One of the main problems is difficulty of controlling outward twisting that must be taken by profile (see for example solution suggested in Italian Patent n° 1231705).

Variable rigid wingsails can be realized by mechanical devices (as described in US patent n° 7,114,456, Italian Patent Application RM2001A000573, and International Patent Application WO03082667) provided within the structure to modify their profile. However, said solutions have the drawback of noticeably increasing weight of the structure and of making it more complex, in view of the high number of components.

Further, flexible wingsails, with variable profile, have been developed (see US patent N° 5,799,601 and Italian Patent Application n° MI2003A001888), having a reduced surface, or other solutions (see Israel Patent Application IL2008001250 and US patent N°6,683,008) wherein mast section is too thin, thus weakening the whole structure.

Generally speaking, all the above solutions have the drawback of being comprised of a large number of elements, making their assembling difficult to be made by a single person, as well high their manufacturing costs.

5 It is object of the present invention that of developing a structure for a wingsail having a variable symmetric profile permitting reducing manufacturing costs and making it easier rigging the boat.

10 It is therefore specific object of the present invention an airfoil sail structure or "wingsail" mounted on a mast of a boat, said structure being characterized in that on said mast are placed, from the bottom to the top, a base element, at least one intermediate modular element, and an upper modular element, said modular elements having a rigid coupling structure with said mast bow of the same, said at least one intermediate and upper modular element having a flexible structure extending from said
15 mast to aft, on said modular elements being wrapped externally a single sail, said upper modular element being coupled to halyards to hoist the sail of the structure.

20 Preferably. According to the invention, said sail has different thicknesses in correspondence of said rigid and flexible structures, further said sail is opened in the back.

Still according to the invention, said rigid bow structure of said modular elements is a box element, having a central hole for inserting the mast.

25 Furthermore, according to the invention, said box element is made of a glass coated PVC closed cell rigid foam, or of a Kevlar[®], or PVC closed cell rigid foam coated with carbon fiber and epoxy resin.

Still, according to the invention, said box element has a NACA profile section.

30 Preferably, according to the invention, said box element is integral to the mast.

Further, according to the invention, said box elements are connected to each other by a trestle structure.

35 Further, according to the invention, said aft flexible structure of said modular elements comprises flexible battens, said battens being coupled on the inner sides of the sail, between said fixed structure and the leech of the sail itself.

Still, according to the invention, said battens are inserted, from aft, into pockets realized into the sail and their aft ends are housed in apposite seats obtained in the respective box element.

5 Further, according to the invention, said seats allow a play of the end of the batten along the vertical plane.

Further, according to the invention, said battens are coupled towards the leech by means that allow also its adjustment.

Preferably, according to the invention, there is a vang equipped with blocks which allow it to work in a substantially vertical direction.

10 Further, according to the invention, the vang is fixed to the base box element and coupled on both sides to the sail and is provided with a central system that brings the action of the vang towards substantially a central/vertical direction.

15 Preferably, according to the invention, there is a device for adjusting the "camber" of the sail.

Still according to the invention, said device for adjusting the "camber" profile of the sail consists of two block and tackle devices, connected, aft, to the lower intermediate modular element, and on the other end towards the mast, to the base box element.

20 Always according to the invention, said device for adjusting the "camber" profile can act on all said modular elements.

25 Further, according to the invention, said device for adjusting the "camber" profile can comprise a plurality of ropes, provided on each side of said intermediate element, and said ropes are coupled on said mast in correspondence of the base of said wingsail structure, by block means.

Furthermore, according to the invention, said device for adjusting the "camber" profile can further comprise a hydraulic system.

Preferably, according to the invention, there is a device for pulling the leech of the sail.

30 Still according to the invention, said mast is mounted on a rotating sphere, in order to turn freely around the hull.

Further, according to the invention, said rotating sphere is mounted on a slide or transverse mechanism that allows the sail structure to tilt sideways.

35 Still according to the invention, said rotating sphere is connected to a "canting keel".

Preferably, according to the invention, a rotating and floating weathervane element is provided on that mast.

Further, according to the invention, said upper box element and said rotating and floating weathervane element are filled with neoprene, or with polyurethane foam.

Preferably, according to the invention, said mast is made of two different parts, the upper one being tapered.

Still according to the invention said box elements are made up of two coupled halves.

Further, according to the invention, the sail has a shaped profile and the single modular elements are sized accordingly.

Furthermore, according to the invention,, said structure can comprise reinforcing battens, inserted within suitable seat realized in said wing, provided between the intermediate box elements, to further strengthen the structure.

Still, according to the invention, said box element can provide a second hole for housing an inflatable element.

Finally, according to the invention, said structure can provide means for a forced rotation of said mast, that can be comprised of a lever for partial rotation of the mast, or of a belt with a gear, making the mast rotating about a 360° angle.

The invention will be now described, for illustrative, but not limitative purposes, with particular reference to the figures of the enclosed drawings, wherein:

figure 1 shows an embodiment of a wingsail structure according to the invention, mounted on a boat;

figures 2A, 2B and 2C respectively show a transverse section and two longitudinal sections of structure of figure 1;

figures 3A and 3B show two longitudinal sections of a wingsail structure with a different arrangement on mast top;

figures 4A, 4B and 4C show particulars of battens rigging;

figures 5A and 5B respectively show a transverse section and a longitudinal section of box element and battens insertion and of block and tackle device according to the invention, while figure 5C show a lateral view of sail structure according to the invention;

figures 6A, 6B and 6C show particulars of vang of structure according to the invention;

figures 7A and 7B shows reaction of sail structure according to the invention in two different adjustment arrangements;

figure 8 shows a second embodiment of a wingsail according to the invention;

5 figure 9 shows a lateral view of a third embodiment of a wingsail according to the invention;

figure 10A shows a front section view of a particular of the mast of the wingsail of figure 9;

figure 10B shows a perspective view of a particular of figure 9;

10 figure 11 shows a plan view of forced rotation mechanism of camber;

figure 12 shows a lateral view of a particular of figure 9;

figure 13 shows a perspective view of a first reinforcement batten of the sail;

15 figure 14 shows a perspective view of a second reinforcement batten of the sail;

figure 15A shows a plan view of a second embodiment of intermediate modular element;

20 figure 15B shows a plan view of a third embodiment of intermediate modular element;

figure 16 shows a lateral view of bladder for supporting leading edge; and

25 figures 17A, 17B and 17C show a plan view of intermediate modular element of figure 15B with battens in different adjustment arrangements.

The following elements are represented in the enclosed figures:

1. wingsail structure;
2. boat;
3. single cloth surface;
- 30 4. intermediate modular elements;
5. upper modular element;
6. floating rotating weathervane;
7. mast;
8. base box element;
- 35 9. intermediate box element;
- 9'. upper box element;
10. batten;

11. band;
12. pockets;
13. slots;
14. battens seat;
5 15. vang;
16. block and tackle devices;
17. vang blocks;
18. vang central element or spacer;
19. mast upper tapering;
10 20. wingsail halyards;
21. bow halyards;
22. gennaker;
23. Genoa;
24. trestle;
15 25. pulling device;
26. symmetric bi-convex profile;
27. asymmetric concave-convex profile;
28. mast foot;
29. camber adjustment system;
20 30. tackled ropes;
31. block means;
32. lever;
33. mast rotation adjustment gear or arm;
34. crane;
25 35. first embodiment of a reinforcement batten;
35'. second embodiment of a reinforcement batten;
36. hole;
37. second hole;
38. inflatable bladder.

30 An embodiment of the invention will be described, comprising a modular system for creating a variable wingsail structure. Said structure can be mounted on existing boats, or preferably on boats designed for exploiting at best said structure.

35 Observing first figures 1, 2 and 3, it is shown a first embodiment of the wingsail structure 1, mounted on a boat 2. Said sail structure 1 is comprised of a single cloth structure 3, preferably characterized by suitable strength and smoothness in correspondence of the leading edge

and in bow portion, and lighter in the poppa part. Said single cloth surface 3 is mounted and wound about a series of modular elements 4, 5, inserted on mast 7, and with a bow rigid structure, and a poppa flexible structure. Upper modular element is coupled with halyards 20 to hoist wingsail.

5 Said modular elements 4 and 5 are comprised of rigid bow box elements 9 and 9' and of simple flexible battens 10, faced verso poppa with respect to mast 7.

10 Last modular element, i.e. the one in correspondence of the boat deck 2, indicated by reference number 8, only has bow box structure 8.

Each one of box elements 8, 9, 9' can be realized by molding and can be comprised of PVC closed cell rigid foam or like, coated by glass, Kevlar or carbon fiber and epoxy resin, with a NACA profile section.

15 Said box elements 9, 9' can freely rotate about mast 7, while box element 8 is integral with the same mast 7.

Mast 7 preferably has a section larger than those available on the market, to obtain a higher rigidity and strength of the structure, and preferably is comprised of high resistance carbon, easily obtained at low cost.

20 Said mast is mounted on mast foot 28 so as to freely rotate with respect to hull 2.

Wingsail halyards 20 and bow halyards 21, for gennaker 22 or Genoa 23, slide within the hollow structure of the mast 7.

25 In embodiment shown in figures 1 and 2, it is shown a floating rotating weathervane 6 fixed at the top of mast 7, suitable for boats needing floating reserve when capsize, such as derive and multi-hull. Preferably, both weathervane 6 and upper box element 9' are filled in with neoprene or foam to prevent the boat upturning at 180° in case of capsize.

30 For example, said solution is not provided in the embodiment of figure 3 and in embodiment shown in figure 8.

35 Rigging wingsail is very easy and efficient, and it can be carried out when moored up at the port, without wind, or outside the port, with bow oriented toward the wind. Said manœuvre occurs as follows: about the mast 7, already rigged, on which box elements 8, 9, 9' have been placed beforehand, stacked and resting on deck, single cloth sail 3 is placed. After having fixed halyard 20 of upper box element 9', and at the top of sail cloth 3, within suitable holes (not shown in the figures), it is raised for few

centimeters, permitting insertion battens 10 on both sides of first modular element 9'.

To this end, pockets 12 are provided on sail cloth 3, verso poppa, and seats 14 are provided on single box elements 9, 9'. Said battens 10 are then tied within pockets 12 and connected each other by a coupling band 11 provided on stern, through slots 13 (see figures 4A, 4B and 4C).

Said seats 14 are so realized to permit a little movement of battens 10 along a vertical plane.

Once hoisted, upper box element 9', the battens 10 positioning and adjustment operation is carried out again for next box elements 9, until completing sail structure 1.

Finally, base box element 8 is rigged, on which vang 15 and central system 18 act, as it will be described in the following.

According to the invention, it is possible providing means (not shown) permitting making box elements 9 integral each other, not only by the action of the sail cloth.

As it is shown in figures 5A, 5B and 5C and in figures 6A, 6B and 6C, structure according to the invention does not provide traditional boom, so that vang 15 is connected to the lowest of modular elements 4. Vang 15 of boat according to the invention provides blocks 17, making it working according to a substantially vertical direction, thus better exploiting wing transverse thrusts. From figure 16B it is understood that vang 15 is coupled with wing 3 on both sides, being it provided a central system 18, or spacer, bringing vang action along a substantially central/vertical direction.

Camber adjustment is controlled by two block and tackle devices 16 (see figures 5A and 5B), connected at an upper end, verso poppa, of lower modular element 4, and at the other end connected to base box element 8, toward mast 7.

As it is shown in figure 5C, box elements 8, 9, 9' can be connected each other, within wing structure 1, by a trestle structure 24, thus keeping sail 3 leading edge aligned. Said trestle, if provided, is directly mounted while realizing wingsail box elements 8, 9, 9'.

Further, a pulling device 25 (shown in figure 5C) can be suitably provided, at a set height, in correspondence of a stern, advantageously permitting acting on leech pulling to prevent its closure downward.

Further, by more or less tying of modular elements 8, 9, 9' battens 10 coupling bands 11, it is possible adjusting tension and thus its adaptability to different wind conditions of each modular element 4, 5.

5 As t is shown in figures 7A and 7B, thanks to the above methods for adjusting wingsail structure 1 camber can provide a symmetric bi-convex profile 26, to easily face up strong breezes; or it can adopt an asymmetric bi-convex profile, with convex and concave-convex plane 27, to conform to low wind breezes.

10 Coming now to observe figure 8, it is shown a second embodiment of the wing according to the invention, wherein mast 7 is realized by two different parts, the upper 19 of which has a tapered shape.

In this case (figure 7C), bow elements 8, 9, 9' are comprised of two halves (8a, 8b; 9a, 9b), that can be coupled each other, to widen when they are lowered or reefed.

15 Further, sail of this embodiment has a shaped rear profile, in correspondence of leech that can be designed on the basis of needing and specific boat, simply suitably designing single modular elements 4 and 5.

20 It is further possible mounting foot rotation sphere 28 along a slide or other transverse mechanism permitting wingsail 1 to be laterally tilted, possibly connecting it to the tilting system of drift.

Wingsail mast of mast 7 according to the invention can be operatively connected with the canting keel, in case the latter is provided.

25 Making reference to figures 9, 10A and 10B, it is observed a third embodiment of wingsail structure 1 according to the invention, which, differently from the previous embodiments, has a camber adjustment device 29 for all the intermediate modular elements 4.

30 Said camber adjustment device 29 provides a plurality of ropes, provided on each side of said intermediate element 4, and are coupled on said mast 7 in correspondence of the base of said wingsail structure 1 base, by block means 31. Ropes 30, by block means 31, parallel adjust camber edge, without requiring using vang or main sail block, as in the previous embodiments. Said adjustment device 29 advantageously permits controlling twisting and adjusting left side and right side of wingsail structure 1 camber.

35 Optionally, in case very large boats are realized, adjustment system can comprise a hydraulic system.

Further, mast 7 forced rotation means can be provided, such as a lever 32, as shown in figure 9, to obtain a partial rotation of the mast, or, as shown in figure 11, said forced rotation means can be comprised of an endless belt gear, permitting a rotation of the wingsail structure 1 of 360°.

5 Always making reference to figure 9, it is observed a particular of wingsail cloth that can have very rigidity features, permitting its bellow folding, so as to occupy less space when sail is lowered.

As shown in figure 12, a rotating crane 34 can be provided at the top of mast 7, on upper module 5, toward bow to transmit gennaker halyard exit a bow, far from leading edge. Same structure can also be used as endplate to reduce induced resistance.

10 Two embodiments of reinforcement battens 35 and 35', or false centering, are shown in figures 13 and 14, to be positioned a bow of wingsail structure 1, inserted within suitable seats of sail cloth, between intermediate rigid box elements 9, to further strengthen structure.

Further embodiments of intermediate box elements 9 are shown in figures 15A, 15B, 16 and 17, having a hole 36, that can have a circular, square or asymmetric shape, to be coupled with must, and a second hole 37 for housing an inflatable bladder 38.

20 Said bladder 38 is inserted within wingsail structure 1 leading edge and is inflated, e.g. by 12 volts compressor, after said structure has been mounted, thus making the same more rigid. Bladder 38 can be realized by a mold, to ensure wished shape, or it can have a generic shape.

25 Just for illustrative purposes, some possible arrangements of wingsail structure 1 camber that can be obtained by the described embodiment are shown in figure 17.

Preferably, it can be provided a system making each intermediate element integral with the sail portion by Velcro® or by other means.

30 Finally, it is possible providing an interface with a wind station to automate camber and leading edge adjustment

Main advantage of the wingsail according to the invention is improvement or performances with respect to traditional solutions, permitting good performances also with low wind conditions.

35 Thus, thank to the solution according to the present invention, it is possible realizing a wingsail structure directly starting from deck,

permitting exploiting full wind thrust, reducing air dispersion in lower part of sail (induced resistance), as it occurs in traditional solutions.

5 Further, present invention permits reducing sail dimensions, permitting saving cloth, and obtaining a better comfort in boat and a reduced heeling thrust.

A further advantage of the structure according to the invention is that of remarkably reducing boat manufacturing costs, since a lower number of components with respect to standard solutions is necessary.

10 Reduction of component number and simplification of elements make it advantageously necessary a reduced labor when sail is rigged and lowered. Said operations can even be completed by a single person.

15 As a further advantage, modularity of elements permits creating airfoil with different dimensions and shape, from the cheap rectangular sail configuration to a tapered sail configuration in case a racing boat is designed.

The present invention has been described with reference to its preferred embodiments, but it is to be understood that modifications and/or variations can be introduced by those skilled in the art without departing from the relevant scope as defined in the enclosed claims.

20

CLAIMS

1. Airfoil sail structure (1) or "wingsail" mounted on a mast (7) of a boat (2), said structure (1) being characterized in that on said mast (7) are placed, from the bottom to the top, a base element (8), at least one intermediate modular element (4), and an upper modular element (5), said modular elements (4, 5, 8) having a rigid coupling structure with said mast (7) bow of the same, said at least one intermediate (4) and upper (5) modular element having a flexible structure extending from said mast (7) to aft, on said modular elements (4, 5, 8) being wrapped externally a single sail (3), said upper modular element being coupled to halyards (20) to hoist the sail (3) of the structure (1).

2. Airfoil sail structure according to claim 1, characterized in that said sail (3) has different thicknesses in correspondence of said rigid and flexible structures.

3. Airfoil sail structure according to one of the previous claims, characterized in that said sail (3) is opened in the back.

4. Airfoil sail structure according to one of the previous claims, characterized in that said rigid bow structure of said modular elements (4, 5, 8) is a box element (8, 9, 9').

5. Airfoil sail structure according to claim 4, characterized in that said box element (8, 9, 9') has a central hole for inserting the mast (7).

6. Airfoil sail structure according to claim 4 or 5, characterized in that said box element (8, 9, 9') is made of a glass coated PVC closed cell rigid foam, or of a Kevlar[®], or PVC closed cell rigid foam coated with carbon fiber and epoxy resin.

7. Airfoil sail structure according to one of the claims 4 - 6, characterized in that said box element (8, 9, 9') has a NACA profile section.

8. Airfoil sail structure according to one of the claims 4 - 7, characterized in that said box element (8) is integral to the mast (7).

9. Airfoil sail structure according to one of the claims 4 - 8, characterized in that said box elements (8, 9, 9') are connected to each other by a trestle structure (24).

10. Airfoil sail structure according to one of the previous claims, characterized in that said aft flexible structure of said modular elements (4, 5) comprises flexible battens (10), said battens being coupled on the inner

sides of the sail (3), between said fixed structure and the leech of the sail (3) itself.

5 11. Airfoil sail structure according to claim 10, characterized in that said battens (10) are inserted, from aft, into pockets (12) realized into the sail (3) and their aft ends are housed in apposite seats (14) obtained in the respective box element (9, 9').

12. Airfoil sail structure according to claim 11, characterized in that said seats (14) allow a play of the end of the batten (10) along the vertical plane.

10 13. Airfoil sail structure according to one of the claims 10 - 12, characterized in that said battens (10) are coupled towards the leech by means (11) that allow also its adjustment.

15 14. Airfoil sail structure according to one of the previous claims, characterized in that there is a vang (15) equipped with blocks (17) which allow it to work in a substantially vertical direction.

20 15. Airfoil sail structure according to claim 14, characterized in that the vang (15) is fixed to the base box element (8) and coupled on both sides to the sail (3) and being provided with a central system (18) that brings the action of the vang (15) towards substantially a central/vertical direction.

16. Airfoil sail structure according to one of the previous claims, characterized in that there is a device for adjusting the "camber" of the sail (3).

25 17. Airfoil sail structure according to claim 16, characterized in that said device for adjusting the "camber" profile of the sail (3) consists of two block and tackle devices (16), connected, aft, to the lower intermediate modular element (4), and on the other end towards the mast (7), to the base box element (8).

30 18. Airfoil sail structure according to claim 17, characterized in that said device for adjusting the "camber" profile can act on all said modular elements (4, 5, 8).

35 19. Airfoil sail structure according to claim 18, characterized in that said device for adjusting the "camber" profile can comprise a plurality of ropes (30), provided on each side of said intermediate element (4, 5, 8), and said ropes (30) are sent back on said mast (7) in correspondence of the base of said wingsail structure (1), by block means (31).

20. Airfoil sail structure according to one of claims 16 - 19, characterized in that said device for adjusting the "camber" profile further comprises a hydraulic system.

5 21. Airfoil sail structure according to one of the previous claims, characterized in that there is a device for pulling (25) the leech of the sail (3).

22. Airfoil sail structure according to one of the previous claims, characterized in that said mast (7) is mounted on a rotating sphere (28), in order to turn freely around the hull (2).

10 23. Airfoil sail structure according to claim 22, characterized in that said rotating sphere (28) is mounted on a slide or (transverse) mechanism that allows the sail structure (1) to tilt sideways.

15 24. Airfoil sail structure according to one of the claims 22 - 23, characterized in that said rotating sphere (28) is connected to a "canting keel".

25. Airfoil sail structure according to one of the previous claims, characterized in that on that mast (7) there is a rotating and floating weathervane element (6).

20 26. Airfoil sail structure according to claim 25, characterized in that said upper box element (9') and said rotating and floating weathervane element (6) are filled with neoprene, or with polyurethane foam.

25 27. Airfoil sail structure according to one of the previous claims, characterized in that said mast (7) is made of two different parts, the upper one (19) being tapered.

28. Airfoil sail structure according to one of the previous claims, characterized in that said box elements (8, 9, 9') are made up of two coupled halves.

30 29. Airfoil sail structure according to claim 27 or 28, characterized in that the sail (3) has a shaped profile and the single modular elements (4, 5) are sized accordingly.

35 30. Airfoil sail structure according to one of the previous claims, characterized in that it comprises reinforcing battens (35; 35'), inserted within suitable seat realized in said wing (3), provided between the intermediate box elements (9), to further strengthen the structure.

31. Airfoil sail structure according to one of the previous claims, characterized in that said box element (8, 9, 9') provides a second hole (37) for housing an inflatable element (38).

5 32. Airfoil sail structure according to one of the previous claims, characterized in that it provides means (32; 33) for a forced rotation of said mast (7), that can be comprised of a lever (32) for partial rotation of the mast, or of a belt with a gear (33), making the mast rotating about a 360° angle, or of hydraulic means.

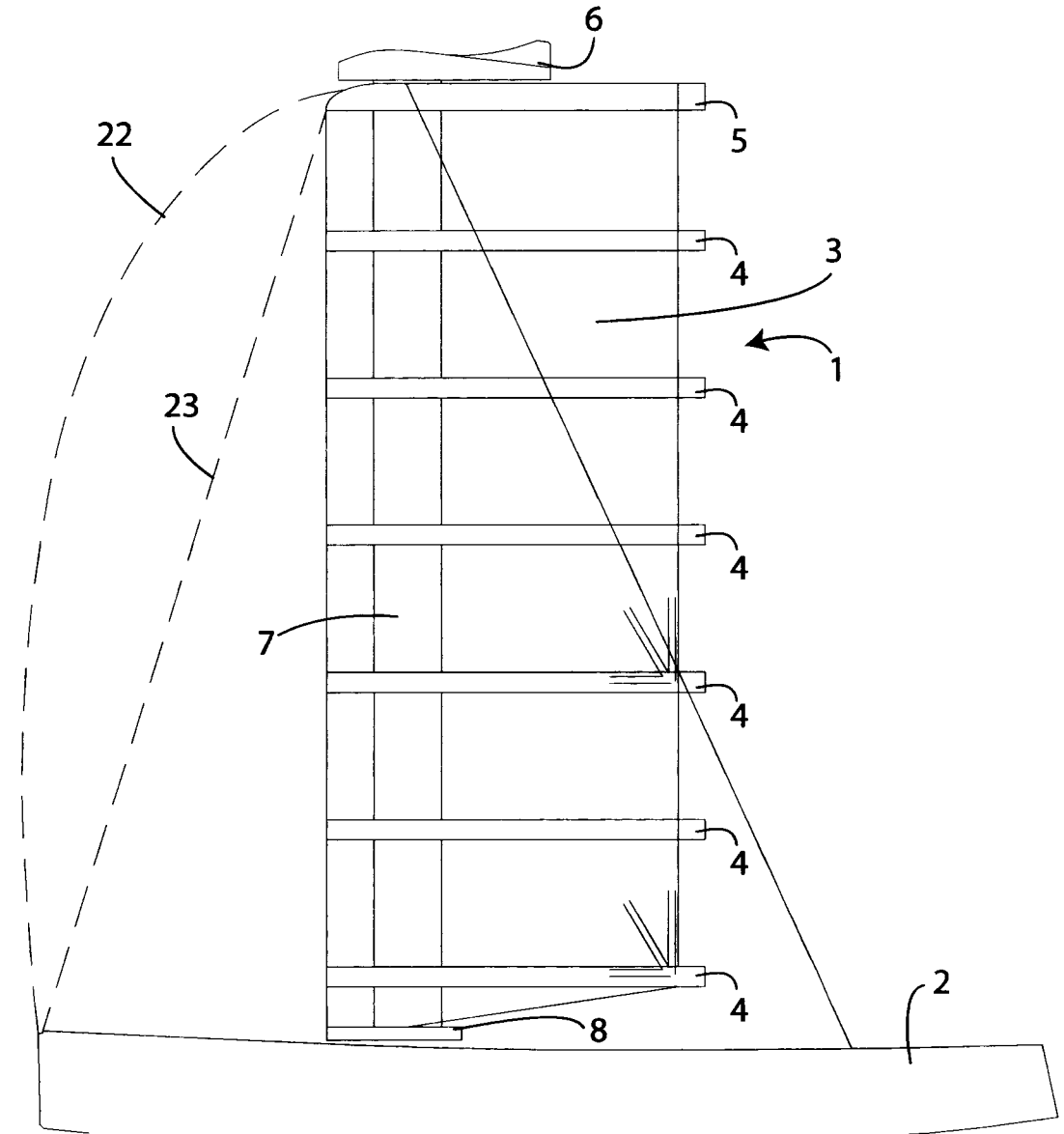

Fig. 1

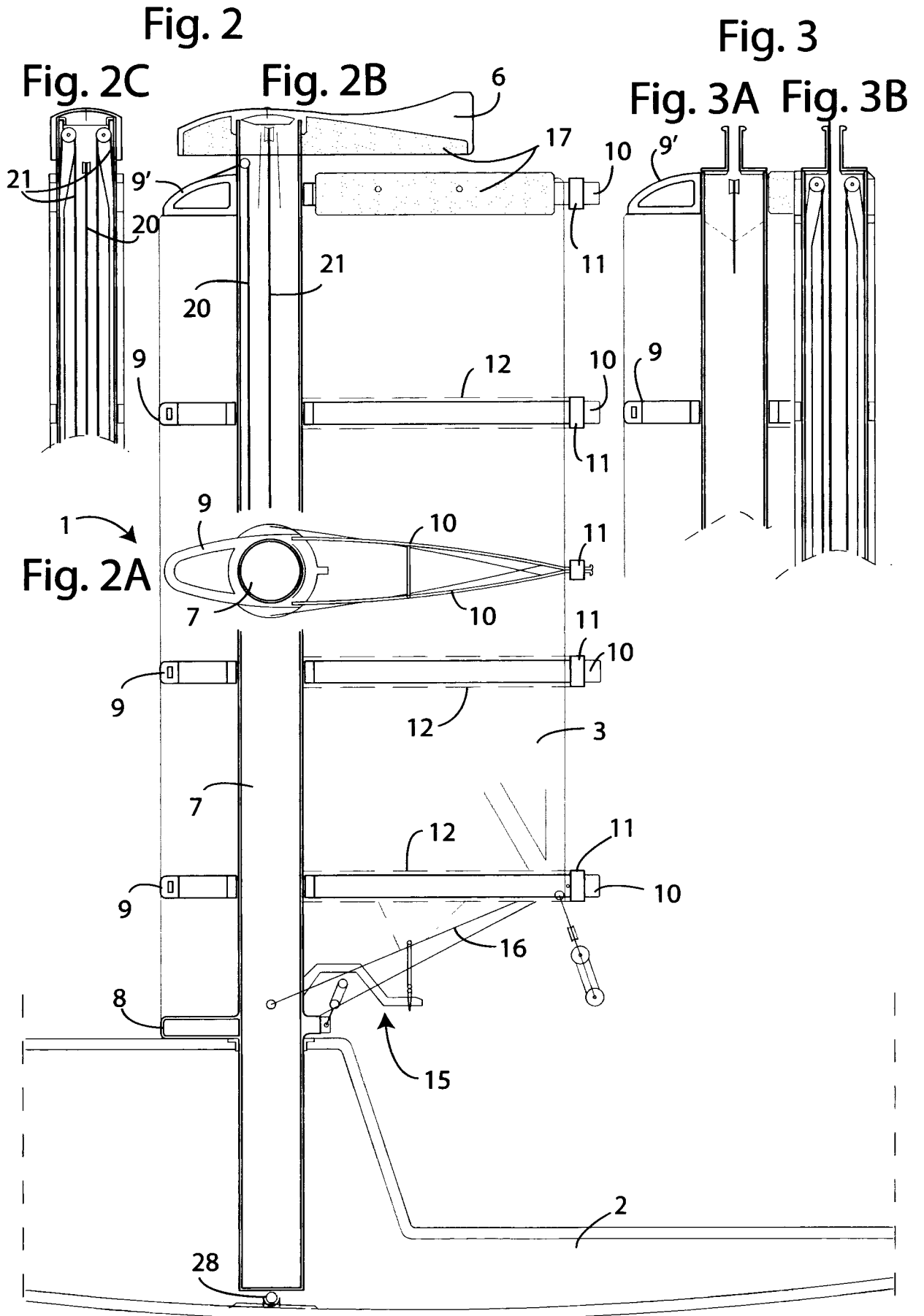

Fig. 4A

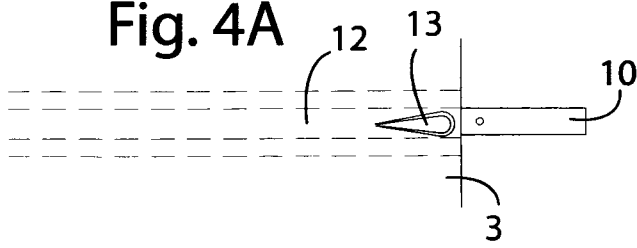

Fig. 4B

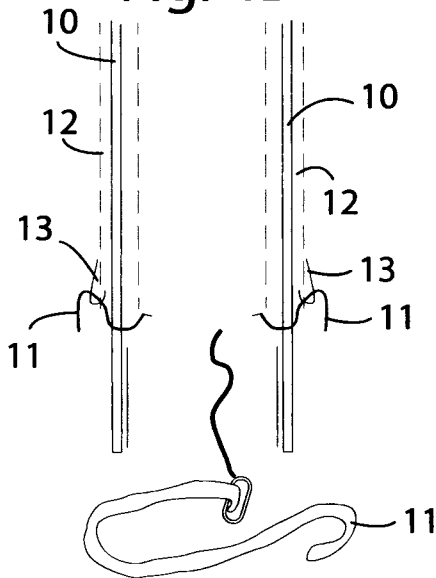

Fig. 4C

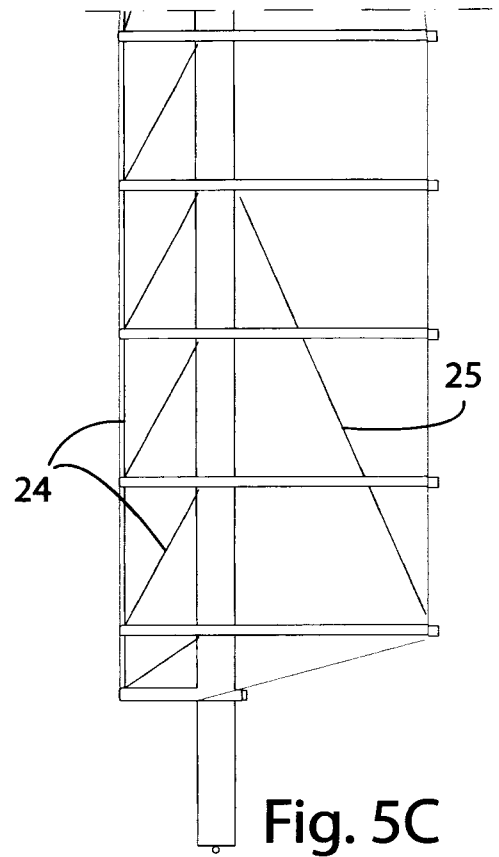
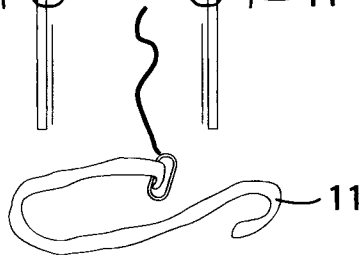

Fig. 5C

Fig. 5A

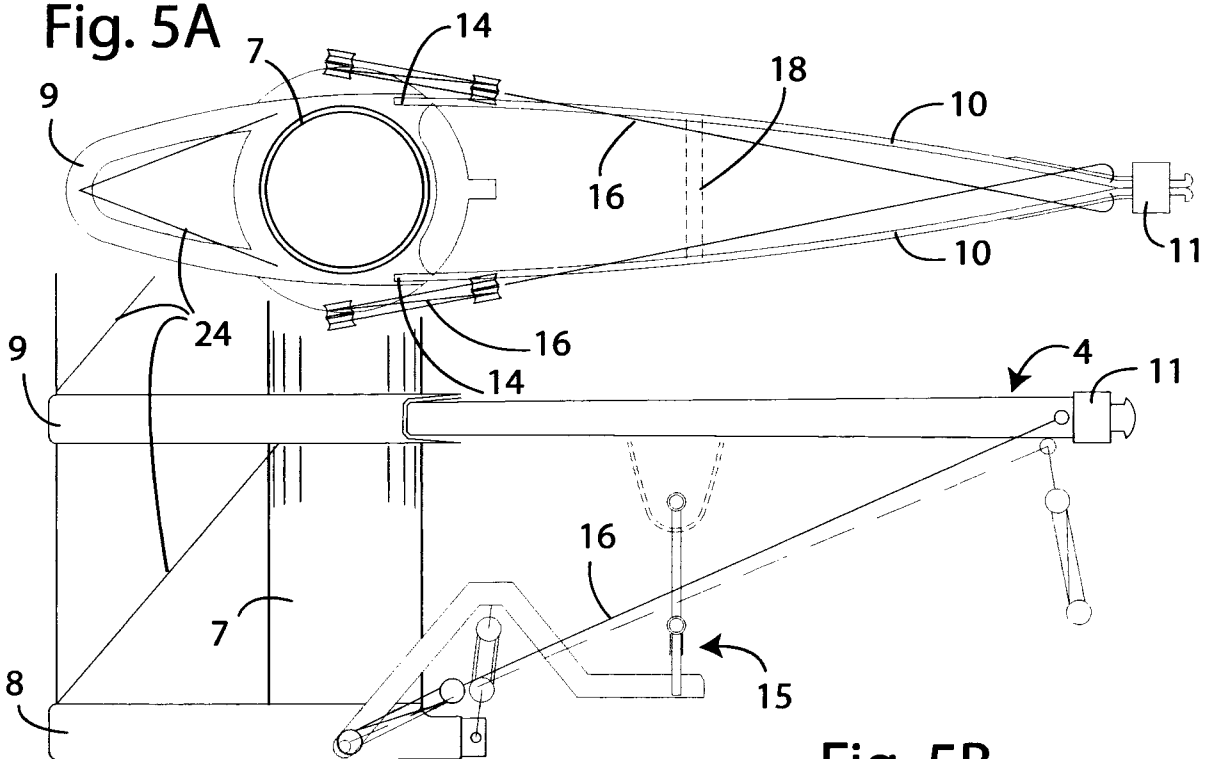

Fig. 5B

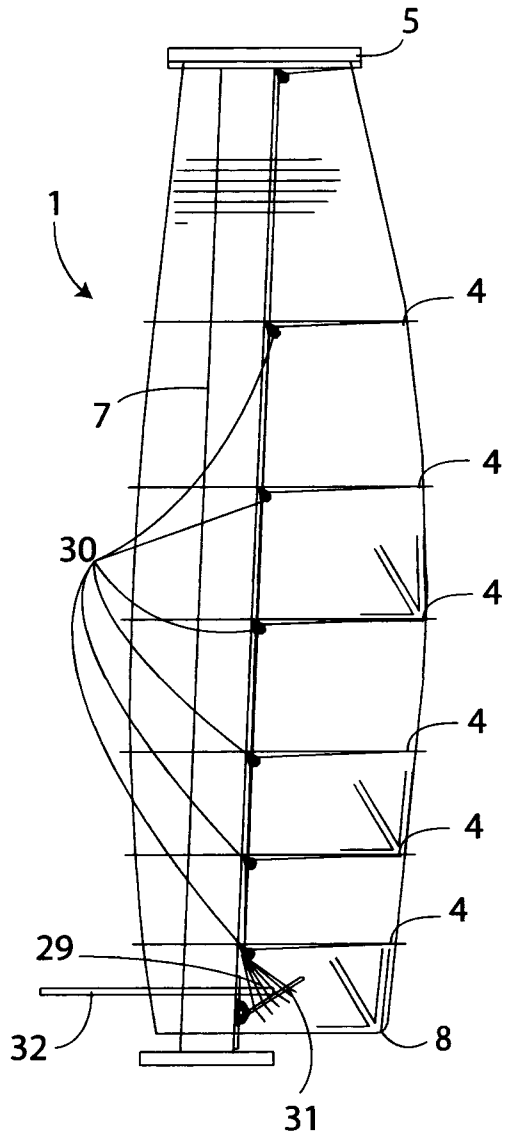

Fig. 9

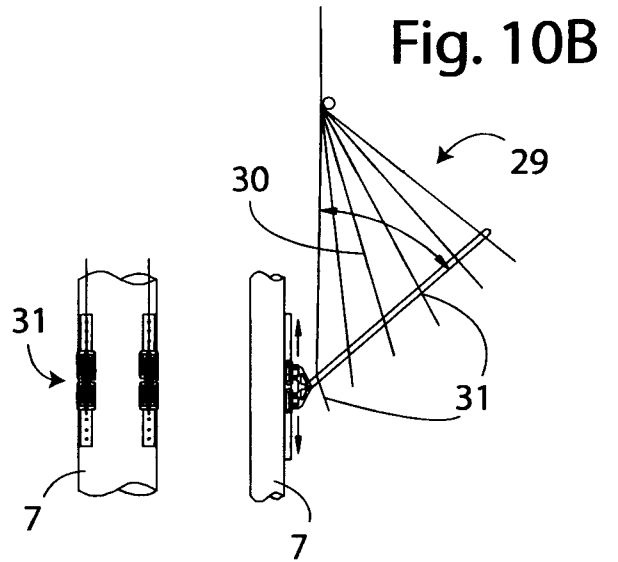

Fig. 10A

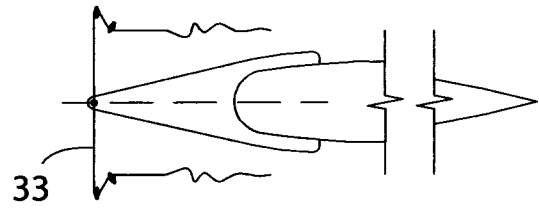

Fig. 11

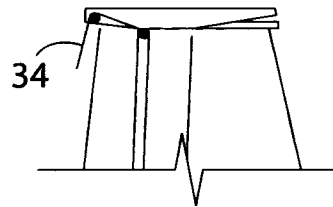

Fig. 12

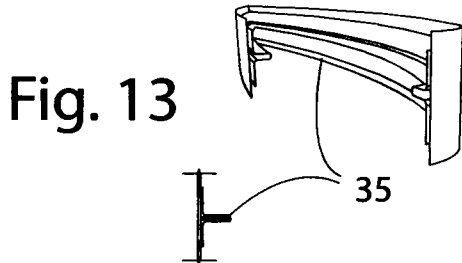

Fig. 13

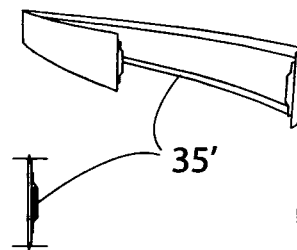

Fig. 14



Fig. 16

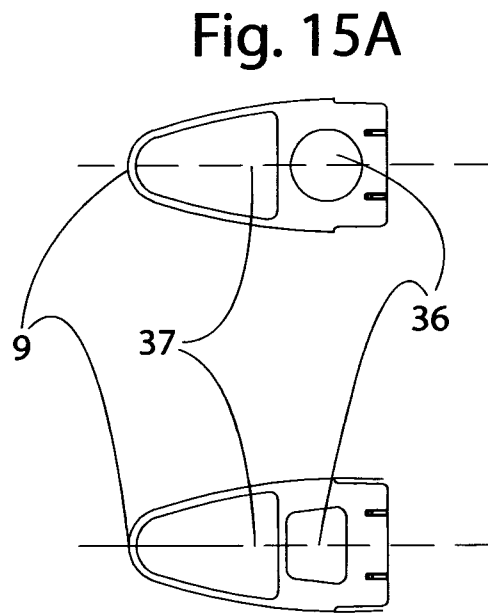

Fig. 15A

Fig. 15B



Fig. 17A



Fig. 17B



Fig. 17C

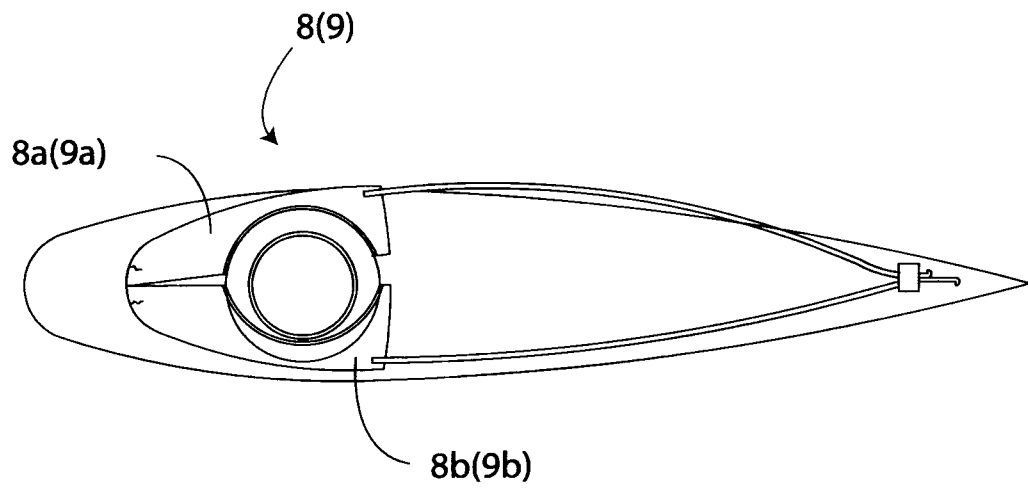

Fig. 7C