

(12) INTERNATIONAL APPLICATION PUBLISHED UNDER THE PATENT COOPERATION TREATY (PCT)

(19) World Intellectual Property Organization
International Bureau



(43) International Publication Date
2 August 2001 (02.08.2001)

PCT

(10) International Publication Number
WO 01/55628 A1

- (51) International Patent Classification⁷: **F16K 51/02**, 1/10
- (21) International Application Number: PCT/US01/02257
- (22) International Filing Date: 23 January 2001 (23.01.2001)
- (25) Filing Language: English
- (26) Publication Language: English
- (30) Priority Data:
60/178,304 26 January 2000 (26.01.2000) US
- (71) Applicant: **SUPERCritical SYSTEMS, INC.**
[US/US]; 4160-A Technology Drive, Fremont, CA 94538 (US).
- (72) Inventors: **LAYMAN, Frederick, P.**; 433 Miwok Court, Fremont, CA 94539 (US). **SUTTON, Thomas, R.**; 1790 Chevalier Drive, San Jose, CA 95124 (US). **BIBERGER, Maximilian, A.**; 737-6 Loma Verde Avenue, Palo Alto, CA 94303 (US).
- (74) Agents: **Haverstock, Thomas, B.** et al.; Haverstock & Owens LLP, 260 Sheridan Avenue, Suite 420, Palo Alto, CA 94306 (US).
- (81) Designated States (*national*): AE, AL, AM, AT, AU, AZ, BA, BB, BG, BR, BY, CA, CH, CN, CR, CU, CZ, DE, DK, DM, EE, ES, FI, GB, GD, GE, GH, GM, HR, HU, ID, IL, IN, IS, JP, KE, KG, KP, KR, KZ, LC, LK, LR, LS, LT, LU, LV, MA, MD, MG, MK, MN, MW, MX, NO, NZ, PL, PT, RO, RU, SD, SE, SG, SI, SK, SL, TJ, TM, TR, TT, TZ, UA, UG, UZ, VN, YU, ZA, ZW.
- (84) Designated States (*regional*): ARIPO patent (GH, GM, KE, LS, MW, MZ, SD, SL, SZ, TZ, UG, ZW), Eurasian patent (AM, AZ, BY, KG, KZ, MD, RU, TJ, TM), European patent (AT, BE, CH, CY, DE, DK, ES, FI, FR, GB, GR, IE, IT, LU, MC, NL, PT, SE, TR), OAPI patent (BF, BJ, CF, CG, CI, CM, GA, GN, GW, ML, MR, NE, SN, TD, TG).
- Published:**
— with international search report
— before the expiration of the time limit for amending the claims and to be republished in the event of receipt of amendments
- For two-letter codes and other abbreviations, refer to the "Guidance Notes on Codes and Abbreviations" appearing at the beginning of each regular issue of the PCT Gazette.*



WO 01/55628 A1

(54) Title: HIGH PRESSURE LIFT VALVE FOR USE IN SEMICONDUCTOR PROCESSING ENVIRONMENT

(57) Abstract: A gate valve (10) includes a plate (14), a seal (24), and a housing (12). The housing includes a passageway (16) and a sealing surface (10). The plate is coupled to the housing. The seal is coupled to the plate. In operation, the plate occupies a position selectable between a sealed position and a retracted position. In the sealed position, the seal seals the plate against the sealing surface. In the retracted position, the plate does not occupy the passageway, which provides free ingress and egress through the passageway. In moving between the sealed position and the retracted position, the plate translates but does not rotate.

HIGH PRESSURE LIFT VALVE FOR USE IN SEMICONDUCTOR PROCESSING ENVIRONMENT

RELATED APPLICATIONS

This application claims priority from U.S. Provisional Patent Application No. 60/178,304 filed on Jan. 26, 2000, which is incorporated by reference.

FIELD OF THE INVENTION

This invention relates to the field of gate valves. More particularly, this invention relates to the field of gates valves intended for use in a clean environment.

BACKGROUND OF THE INVENTION

Typically, a loading port of a pressure vessel uses an external door for sealing the loading port. One or more mechanical fasteners hold the external door to the pressure vessel causing the external door to form a seal with the pressure vessel. Typically, the mechanical fasteners are chosen from the group including quick release clamps, external self-locking ring clamps, and bolts. The pressure vessel employing the external door with the mechanical fasteners poses at least two problems for a semiconductor wafer fab. The first problem is that the mechanical fasteners generate more particulate matter than is allowable in the semiconductor wafer fab. The second problem is that fastening and unfastening the mechanical fasteners requires excessive time for sealing the pressure vessel. The excessive time leads to inefficient automation of the semiconductor wafer fab.

What is needed is a method of sealing a loading port of a pressure vessel which does not use external fasteners.

What is needed is a method of sealing a loading port of a pressure vessel which produces less particulate matter.

What is needed is a method of sealing a loading port of a pressure vessel which results in less time for opening and closing the pressure vessel.

SUMMARY OF THE INVENTION

The present invention is a gate valve. The gate valve includes a plate, a seal, and a housing. The housing includes a passageway and a sealing surface. The plate is coupled to the housing. The seal is coupled to the plate. In operation, the plate occupies a position selectable between a sealed position and a retracted position. In the sealed position, the seal seals the plate to the sealing surface. In the retracted position, the plate does not occupy the passageway, which provides free ingress and egress through the passageway. In moving between the sealed position and the retracted position, the plate translates but does not rotate.

BRIEF DESCRIPTION OF THE DRAWINGS

FIG. 1 illustrates the preferred gate valve of the present invention.

FIG. 2 illustrates the preferred gate valve of the present invention incorporated as part of a supercritical processing chamber for a semiconductor wafer.

FIGS. 3A and 3B illustrates an alternative gate valve of the present invention incorporated as part of an alternative supercritical processing chamber for the semiconductor wafer.

DETAILED DESCRIPTION OF THE PREFERRED EMBODIMENT

The present invention is a gate valve intended for use in a semiconductor processing environment where there is a need for sealing a high pressure from a low pressure and where there is a need to maintain a clean environment.

The preferred gate valve of the present invention is illustrated in FIG. 1. The preferred gate valve 10 includes a housing 12 and a plate 14. Preferably, the housing includes a passageway 16, a plate shaft 18, and a sealing surface 20. The plate 14 preferably includes an o-ring groove 22 for an o-ring 24. Alternatively, the o-ring groove 22 is part of the sealing surface 20 of the housing 12. Further alternatively, the o-ring 24 is replaced by any polymeric seal or other seal appropriate for repeated sealing.

In a sealed position 26, the plate 14 rests against the sealing surface 20. In a retracted position 28, the plate 14 allows free passage through the passageway 16. In moving between the sealed position 26 and the retracted position 28, the plate 14 translates but does not rotate. Since the plate 14 does not rotate, particle generation is minimized which is highly advantageous for the clean environment especially the semiconductor processing environment.

The preferred gate valve 10 of the present invention is further illustrated in FIG. 2, which shows the preferred gate valve 10 incorporated as part of a supercritical processing chamber 30. The supercritical processing chamber 30 includes the housing 12, the plate 14, the passageway 16, the plate shaft 18, the sealing surface 20, a

pressure cylinder 32, a gas handling configuration 34, and a wafer processing cavity 36. The pressure cylinder 32 preferably includes a piston 38, a cylinder shaft 40, and a return spring 42. The piston 38 is coupled to the cylinder shaft 40 at an outer diameter of the piston 38 where a piston seal (not shown) seals the piston 38 to the cylinder shaft 40. The piston 38 is also coupled to the plate 14 by a first rod 39. The return spring 42 is coupled to the piston 38 and a cylinder bottom 44. The gas handling configuration 34 includes an inlet/outlet port 46 and first and second valves, 48 and 50. The first valve 48 couples the inlet/outlet port 46 to the pressure cylinder 32. The second valve couples the inlet/outlet port 46 to the wafer processing cavity 36.

Initially, the plate 14 begins in the retracted position 28 and the first and second valves, 48 and 50, begin in a closed configuration. In operation, the semiconductor wafer 52 is inserted into the wafer processing cavity 36 by a robot (not shown). Alternatively, the semiconductor wafer 52 is manually inserted into the wafer processing cavity 36. Next, the first valve 48 is opened causing the plate 14 to translate to the sealed position 26. Following this, the second valve 50 is opened. This pressurizes the wafer processing cavity 36 and causes the plate 14 to seal against the sealing surface 20. The semiconductor wafer 36 is then processed, preferably using supercritical carbon dioxide. After processing, the wafer processing cavity 36 and the cylinder 32 are depressurized causing the plate 14 to translate to the retracted position 28. The semiconductor wafer 36 is then removed from the wafer processing cavity 36.

It will be readily apparent to one skilled in the art that the preferred gate valve 10 is appropriate for high pressure processing which is below supercritical conditions. Thus, the preferred gate valve 10 is appropriate for any application separating a high pressure from a low pressure. Further, it will be readily apparent to one skilled in the art that the pressure cylinder 32 can be replaced by an alternative actuating device such as an electric motor or another device which electromagnetically induces a force.

An alternative pressure chamber incorporating an alternative gate valve of the present invention is illustrated in FIGS. 3A and 3B. The alternative pressure chamber 30A includes the alternative gate valve 10A and an alternative wafer processing cavity 36A. The alternative gate valve 10A includes an alternative housing 12A, an alternative plate 14A, an alternative sealing surface 22A, and second and third rods, 60 and 62. In operation, the first and second rods, 60 and 62, pull the alternative plate 14A against the alternative sealing surface 22A and then the alternative wafer processing cavity is pressurized. After processing, the alternative wafer processing cavity is depressurized and the alternative plate is pushed away from the alternative sealing surface 22A.

It will be readily apparent to one skilled in the art that other various modifications may be made to the preferred embodiment without departing from the spirit and scope of the invention as defined by the appended claims.

CLAIMS

I claim:

1. A gate valve comprising:
 - a. a plate;
 - b. means for sealing coupled to the plate; and
 - c. a housing comprising a passageway and a sealing surface around the passageway, the plate coupled to the housing such that in operation the plate occupies a position selectable between a sealed position, where the means for sealing seals the plate against the sealing surface, and a retracted position, where the plate does not occupy the passageway, and further such that in operation the plate translates between the sealed position and the retracted position without rotation of the plate.
2. The gate valve of claim 1 wherein the means for sealing comprises an o-ring.
3. The gate valve of claim 1 further comprising a plate shaft, wherein in operation the plate translates through the plate shaft between the retracted position and the sealed position.
4. The gate valve of claim 3 wherein the passageway comprises a first rectangular cross-section and further wherein the plate shaft comprises a second rectangular cross-section.
5. The gate valve of claim 4 wherein the plate comprises a rectangular shape sized to translate through the plate shaft.
6. The gate valve of claim 5 wherein the first cross-section of the passageway comprises sufficient space for free travel of a semiconductor substrate and a substrate handling mechanism.
7. The gate valve of claim 1 further comprising means for moving the plate between the sealed position and the retracted position.
8. The gate valve of claim 7 wherein the means for moving the plate comprise a pair of rods configured to pull the plate against the sealing surface

for positioning the plate in the sealed position, configured to push the plate away from the sealing surface for the plate in the retracted position, and configured to allow access through the passageway by a workpiece for the plate in the retracted position.

9. The gate valve of claim 7 wherein the means for moving the plate comprises a rod configured to push the plate against the sealing surface for positioning the plate in the sealed position and configured to pull the plate away from the sealing surface for positioning the plate in the retracted position.
10. The gate valve of claim 9 wherein the means for moving the plate comprises a pressure cylinder and further wherein the pressure cylinder is actuated to push the plate against the sealing surface.
11. The gate valve of claim 10 wherein the plate seals a processing cavity from atmosphere and further wherein a processing fluid sequentially pressurizes the pressure cylinder then pressurizes the processing cavity.
12. The gate valve of claim 10 wherein the means for moving the plate comprises a spring for returning the plate to the retracted position.
13. The gate valve of claim 7 wherein the means for moving the plate comprises a pressure cylinder.
14. The gate valve of claim 7 wherein the means for moving the plate comprises a spring.
15. The gate valve of claim 7 wherein the means for moving the plate comprises an electric motor.
16. The gate valve of claim 7 wherein the means for moving the plate utilizes an electromagnetically induced force.
17. A gate valve comprising:
 - a. a plate;
 - b. means for sealing coupled to the plate;
 - c. a pressure cylinder coupled to the plate;

- d. a housing comprising a passageway and a sealing surface around the passageway, the pressure cylinder coupled to the housing such that in operation the pressure cylinder positions the plate in a position selectable between a sealed position, where the means for sealing seals the plate against the sealing surface, and a retracted position, where the plate does not occupy the passageway, and further such that in operation the pressure cylinder translates the plate between the sealed position and the retracted position without rotation of the plate; and
 - e. means for actuating the pressure cylinder comprising a processing fluid such that in operation the processing fluid sequentially pressurizes the pressure cylinder to position the plate in the sealed position and then pressurizes a processing cavity.
18. A method of sealing a workpiece entrance to a high pressure processing cavity comprising the steps of:
- a. translating a plate without rotation from a retracted position through to a sealing position;
 - b. pressing the plate in the sealing position to a sealing surface encircling the workpiece entrance; and
 - c. pressurizing the high pressure processing cavity.
19. The method of claim 18 wherein the steps of translating the plate and pressing the plate comprise pressurizing a pressure cylinder with a processing gas and further wherein the step of pressurizing the high pressure processing cavity comprises pressurizing the high pressure cavity with the processing gas.

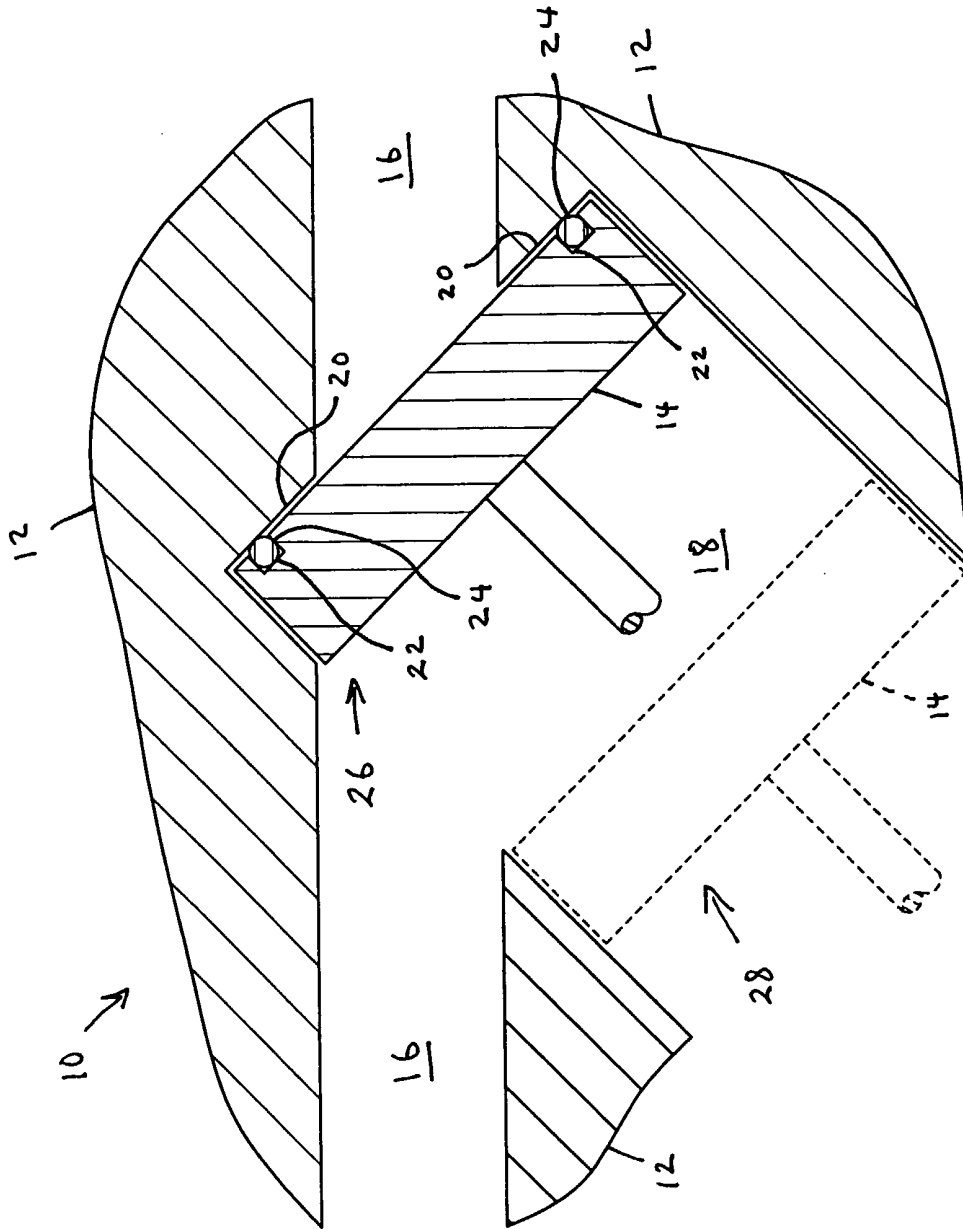

FIG. 1

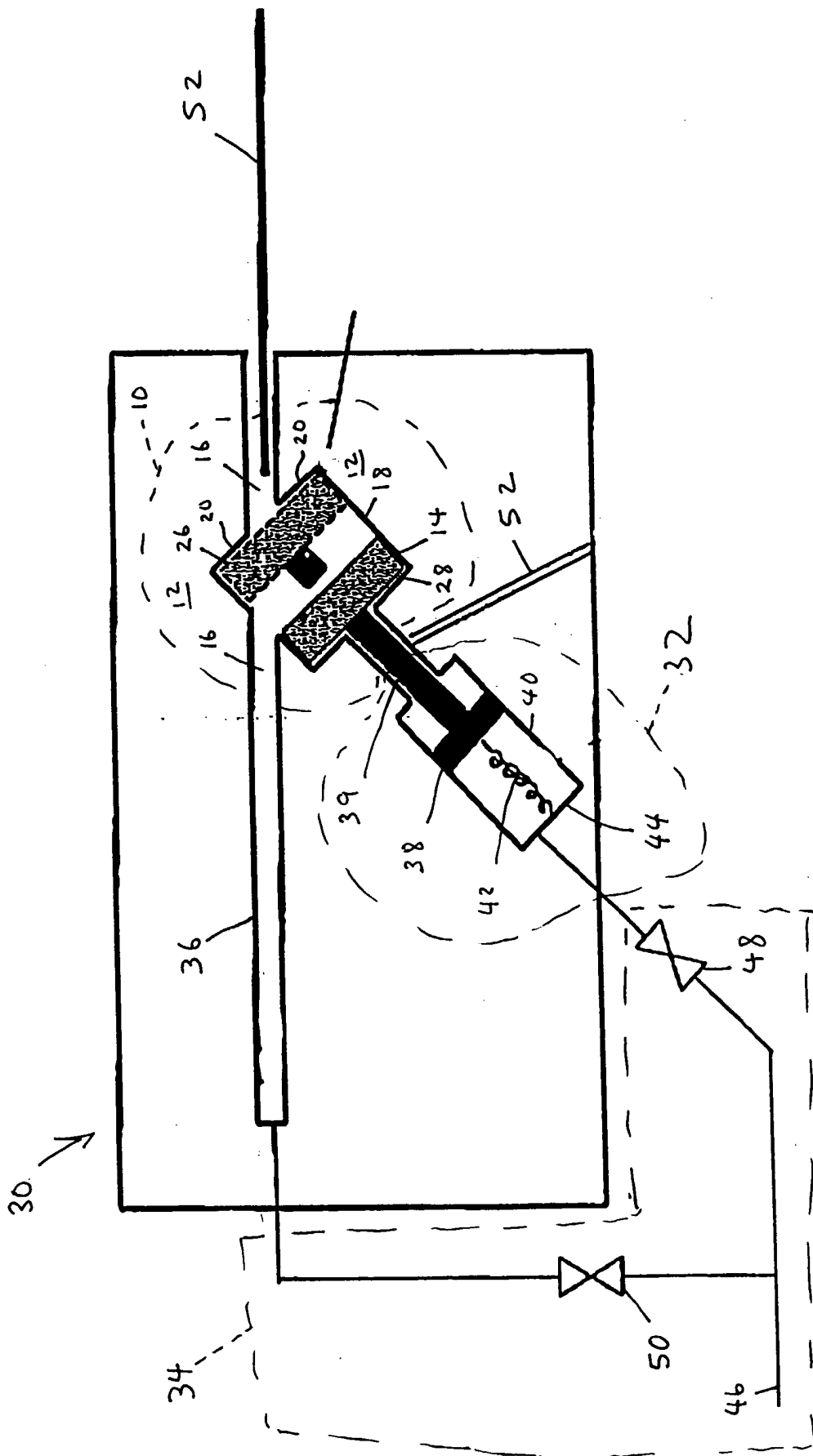

FIG. 2

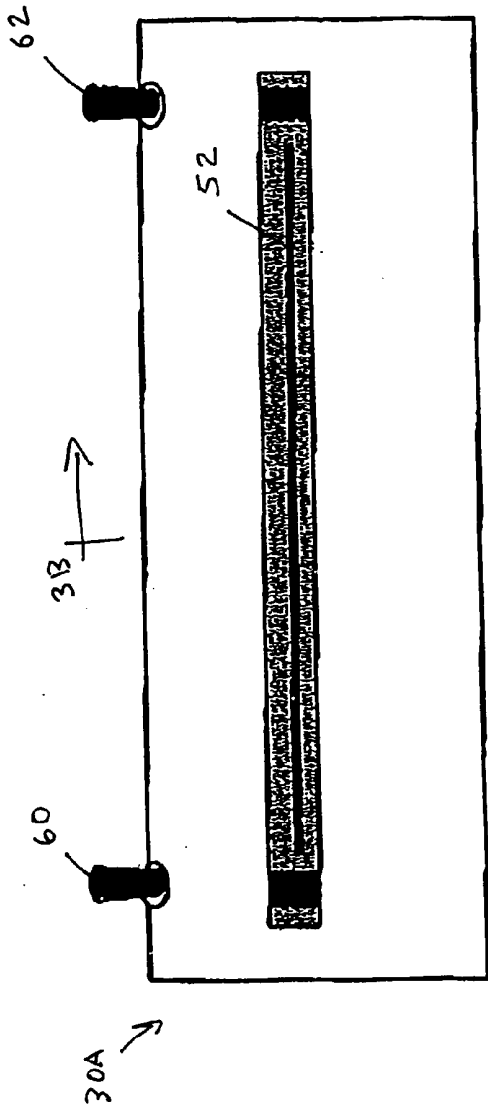

FIG. 3A

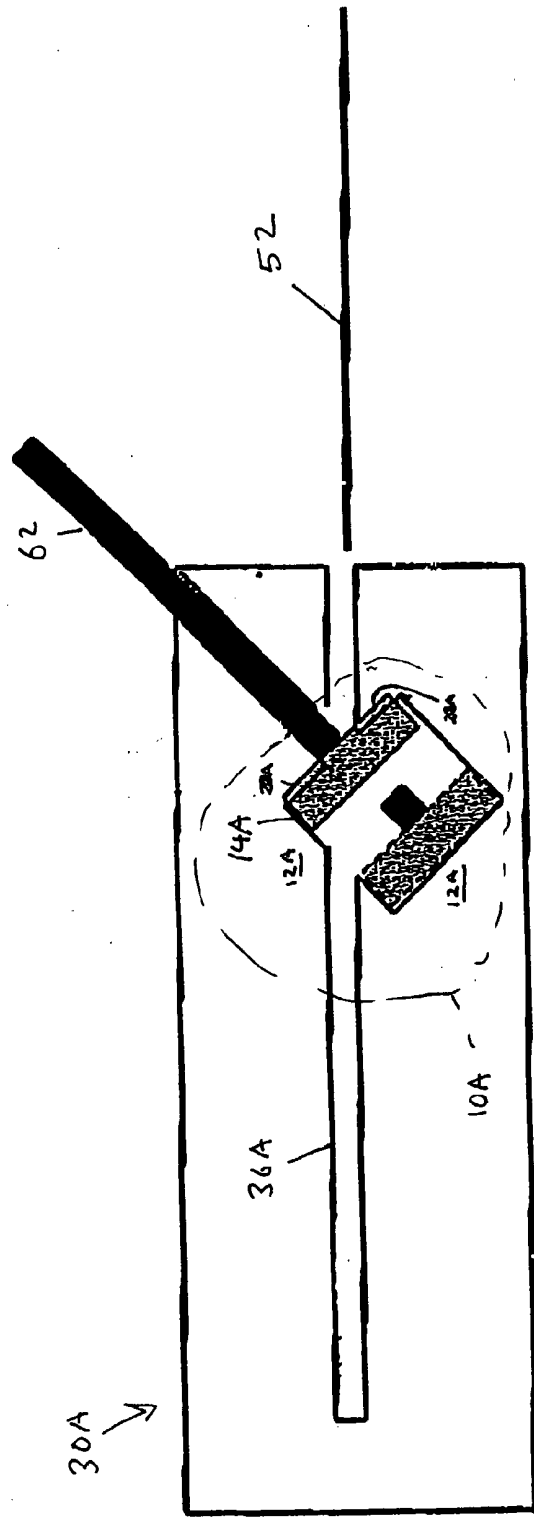

FIG. 3B

INTERNATIONAL SEARCH REPORT

International Application No
PCT/US 01/02257

A. CLASSIFICATION OF SUBJECT MATTER IPC 7 F16K51/02 F16K1/10		
According to International Patent Classification (IPC) or to both national classification and IPC		
B. FIELDS SEARCHED		
Minimum documentation searched (classification system followed by classification symbols) IPC 7 F16K		
Documentation searched other than minimum documentation to the extent that such documents are included in the fields searched		
Electronic data base consulted during the international search (name of data base and, where practical, search terms used) EPO-Internal		
C. DOCUMENTS CONSIDERED TO BE RELEVANT		
Category °	Citation of document, with indication, where appropriate, of the relevant passages	Relevant to claim No.
X	EP 0 453 867 A (APPLIED MATERIALS INC) 30 October 1991 (1991-10-30)	1-7,9, 10, 12-14,18 17
A	column 3, line 1 - line 51; figures ----	
A	FR 1 499 491 A (ALBERT HANDTMANN METALLGIESSEREI) 25 January 1968 (1968-01-25) page 2, right-hand column, paragraph 3; figure 1 -----	1,17,18
<input type="checkbox"/> Further documents are listed in the continuation of box C.		
<input checked="" type="checkbox"/> Patent family members are listed in annex.		
° Special categories of cited documents :		
A document defining the general state of the art which is not considered to be of particular relevance	*T* later document published after the international filing date or priority date and not in conflict with the application but cited to understand the principle or theory underlying the invention	
E earlier document but published on or after the international filing date	*X* document of particular relevance; the claimed invention cannot be considered novel or cannot be considered to involve an inventive step when the document is taken alone	
L document which may throw doubts on priority claim(s) or which is cited to establish the publication date of another citation or other special reason (as specified)	*Y* document of particular relevance; the claimed invention cannot be considered to involve an inventive step when the document is combined with one or more other such documents, such combination being obvious to a person skilled in the art.	
O document referring to an oral disclosure, use, exhibition or other means	*&* document member of the same patent family	
P document published prior to the international filing date but later than the priority date claimed		
Date of the actual completion of the international search <p style="text-align: center;">11 May 2001</p>	Date of mailing of the international search report <p style="text-align: center;">21/05/2001</p>	
Name and mailing address of the ISA European Patent Office, P.B. 5818 Patentlaan 2 NL - 2280 HV Rijswijk Tel. (+31-70) 340-2040, Tx. 31 651 epo nl, Fax: (+31-70) 340-3016	Authorized officer <p style="text-align: center;">Christensen, J</p>	

INTERNATIONAL SEARCH REPORT

Information on patent family members

International Application No

PCT/US 01/02257

Patent document cited in search report	Publication date	Patent family member(s)	Publication date
EP 0453867 A	30-10-1991	DE 69103316 D	15-09-1994
		DE 69103316 T	27-04-1995
		ES 2062595 T	16-12-1994
		JP 2682904 B	26-11-1997
		JP 4228978 A	18-08-1992
		KR 210693 B	15-07-1999
		US 5226632 A	13-07-1993
FR 1499491 A	25-01-1968	NONE	