

(19)



Europäisches Patentamt
European Patent Office
Office européen des brevets



(11)

EP 1 520 979 A1

(12)

EUROPEAN PATENT APPLICATION
published in accordance with Art. 158(3) EPC

(43) Date of publication:
06.04.2005 Bulletin 2005/14

(51) Int Cl.7: **F02M 47/00**, F02M 55/02,
F02D 41/12, F02D 41/38

(21) Application number: **03738580.4**

(86) International application number:
PCT/JP2003/008275

(22) Date of filing: **30.06.2003**

(87) International publication number:
WO 2004/007945 (22.01.2004 Gazette 2004/04)

(84) Designated Contracting States:
**AT BE BG CH CY CZ DE DK EE ES FI FR GB GR
HU IE IT LI LU MC NL PT RO SE SI SK TR**
Designated Extension States:
AL LT LV MK

(72) Inventor: **Okamoto, Kenji,**
Bosch Automotive Systems Corp.
Higashimatsuyama-shi, Saitama 355-8603 (JP)

(30) Priority: **10.07.2002 JP 2002201412**

(74) Representative: **Schwabe - Sandmair - Marx**
Stuntzstrasse 16
81677 München (DE)

(71) Applicant: **Bosch Automotive Systems
Corporation**
Tokyo 150-0002 (JP)

(54) **ACCUMULATOR-TYPE FUEL INJECTION DEVICE**

(57) In a fuel injection apparatus (1) configured so that high-pressure fuel from a common rail (2) is supplied to an injector (8) through a pressure booster (4), it is discriminated whether reduction of the fuel pressure in the common rail (2) is necessary, the spill amount of the high-pressure fuel necessary for pressure reduction is computed when pressure reduction is discriminated to be necessary, and a control solenoid valve (48) is open/close controlled to spill said spill amount of the high-pressure fuel to the low-pressure side at a time point when fuel injection from the injector (8) is not being conducted.

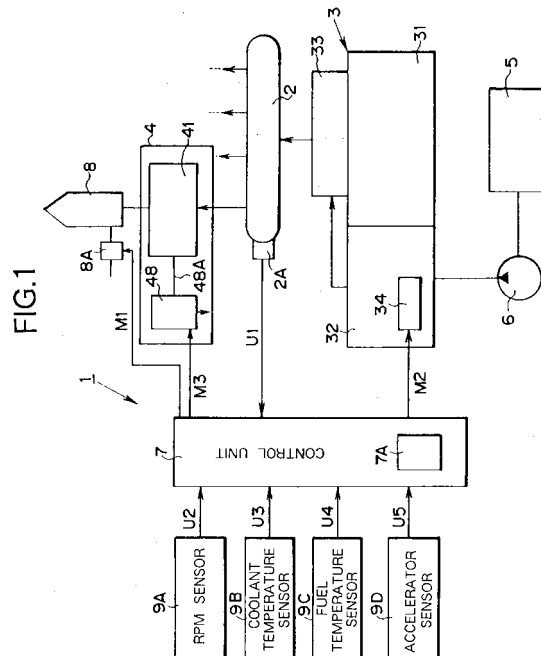

EP 1 520 979 A1

DescriptionTECHNICAL FIELD

[0001] The present invention relates to a common rail fuel injection apparatus that injects/supplies high-pressure fuel once accumulated at high pressure in a common rail (pressure accumulation chamber) into diesel engine cylinders by means of injectors.

BACKGROUND ART

[0002] The conventional common rail fuel injection apparatus has the problem of causing problems in the operation of injecting fuel from the injectors. One of these is that when fuel injection is abruptly terminated because, for instance, the driver has taken his or her foot off the accelerator pedal to invoke engine braking effect, the rail pressure rises to above the desired pressure so that when fuel injection is resumed, high-pressure fuel is injected at one time within a short period. Japanese Unexamined Patent Publication No. Hei 11 (1999)-173192, for example, teaches a configuration for overcoming this drawback by utilizing the fact that a delay arises between the time when the solenoid valve of an injector operates and the time when the valve body actually lifts to assume the valve-open state, i.e., by opening the solenoid valve of the injector in the course of this delay for a time period shorter than the delay, thereby spilling high-pressure fuel in the common rail to the low pressure side through the solenoid valve and lowering the rail pressure, without conducting fuel injection into the cylinder from the injector.

[0003] With this proposed configuration, however, the solenoid valve opening operation for lowering the fuel pressure in the common rail using the solenoid valve of the injector must be effected under very restricted conditions and, moreover, the fuel must be spilled within a period even shorter than the short period of about several msec during which the solenoid valve of the injector opens the valve body. Problems therefore exist in the points that the reduction rate of the rail pressure is difficult to increase, that when the operating state of the engine changes radically, it is hard to keep up by lowering the rail pressure to appropriate values, and that cases frequently arise in which optimum combustion cannot be achieved in the cylinder.

[0004] An object of the present invention is to provide a common rail fuel injection apparatus that enables the foregoing problems in the prior art to be solved.

[0005] Another object of the present invention is to provide a common rail fuel injection apparatus that enables reduction of rail pressure to be conducted rapidly.

[0006] Another object of the present invention is to provide a common rail fuel injection apparatus that enables fuel injection operation to be conducted stably.

DISCLOSURE OF THE INVENTION

[0007] The present invention concerns a common rail fuel injection apparatus configured to send high-pressure fuel once accumulated in a common rail to injectors through a pressure booster, specifically to one that enables reduction of rail pressure to be conducted at high speed by using a boost pressure control solenoid valve installed in the pressure booster to spill high-pressure fuel in the common rail to the low-pressure side.

[0008] The charactering feature of the present invention is the point that, in a common rail fuel injection apparatus configured so that high-pressure fuel from a common rail for accumulating fuel supplied under pressure from a fuel supply pump is sent through a pressure booster to an injector open/closed controlled by fuel injection control means and wherein pressure boost control in the pressure booster is conducted by using a control solenoid valve to regulate the amount of the high-pressure fuel supplied to the pressure booster that is spilled to the low-pressure side, there are provided discrimination means for discriminating whether reduction of the fuel pressure in the common rail is necessary, spill amount computing means for computing a high-pressure fuel spill amount necessary for pressure reduction when the discrimination means discriminates that pressure reduction is necessary, and solenoid valve control means responsive to the spill amount computing means and the fuel injection control means for open/close controlling the control solenoid valve so as to spill the high-pressure fuel to the low-pressure side at a time point when fuel injection from the injector is not being conducted.

[0009] Since rapid reduction of the rail pressure is performed by using the control solenoid valve preinstalled in the pressure booster to spill high-pressure fuel in the common rail to the low-pressure side, the rail pressure can be effectively reduced in a short time, merely by making minor changes in the configuration of the control section or to its program. Therefore, the configuration enables the rail pressure of the common rail to be reduced more rapidly than heretofore despite its low cost, and since any abrupt fuel injection termination operation that occurs can be prevented from giving rise to problems in the fuel injection operation thereafter, it is possible to realize a common rail fuel injection apparatus that is low in cost and high in performance.

[0010] The control solenoid valve can be configured to be open/close controlled so as to spill the high-pressure fuel to the low-pressure side for a prescribed time period at said time point. Further, spill amount computing means for computing a high-pressure fuel spill amount necessary for pressure reduction can be further provided, and the solenoid valve control means can be adapted to open/close control the control solenoid valve in response to the spill amount computing means and the fuel injection control means so as to spill said spill amount of the high-pressure fuel to the low-pressure

side at a time point when fuel injection from the injector is not being conducted. A configuration can be adopted wherein the discrimination means includes desired pressure computing means for computing a desired pressure of the common rail and a rail pressure sensor for detecting actual pressure of the common rail and discriminates whether pressure reduction is necessary by comparing the desired pressure and the actual rail pressure.

BRIEF DESCRIPTION OF THE DRAWINGS

[0011]

Fig. 1 is a schematic diagram showing an embodiment of the fuel injection apparatus for an internal combustion engine in accordance with the present invention.

Fig. 2 is a sectional view showing structural details of a pressure booster shown in Fig. 1.

Fig. 3 is a block diagram for explaining structural details of a control unit shown in Fig. 1.

Fig. 4 is a flowchart of a control program executed in a microcomputer of the control unit for controlling the pressure booster.

Fig. 5A is a graph showing the open/close operation of a control solenoid valve in the case of not conducting common rail pressure reduction operation.

Fig. 5B is a graph showing the fuel injection operation at the injector in the case of not conducting common rail pressure reduction operation.

Fig. 5C is a graph showing the time-course change in the fuel injection from the injector, etc., in the case of not conducting common rail pressure reduction operation.

Fig. 6A is a graph showing the open/close operation of the control solenoid valve in the case of conducting rapid pressure reduction.

Fig. 6B is a graph showing the fuel injection operation at the injector in the case of conducting rapid pressure reduction.

Fig. 6C is a graph showing the time-course change in the fuel injection from the injector, etc., in the case of conducting rapid pressure reduction.

BEST MODE OF CARRYING OUT THE INVENTION

[0012] In order to clarify the present invention in greater detail, it will now be explained with reference to the attached drawings.

[0013] Fig. 1 is a schematic diagram showing an embodiment of the fuel injection apparatus for an internal combustion engine in accordance with the present invention. The fuel injection apparatus 1 is a common rail fuel injection apparatus for an internal combustion engine, which is equipped with a common rail 2 and a high-pressure pump assembly 3 for supplying high-pressure fuel to the common rail 2 and is configured to supply

high-pressure fuel accumulated in the common rail 2 to an injector 8 through a pressure booster 4. The injector 8 is equipped with a solenoid valve 8A for injection control and the apparatus is configured to open/close control the solenoid valve 8A in response to a first control signal M1 from a control unit 7 so that a required quantity of the high-pressure fuel is injected into an associated cylinder of an unshown diesel engine at a prescribed time point. In the interest of simplifying the drawing, only one set of the pressure booster 4 and injector 8 is shown, but there are actually provided a number of sets equal to the number of cylinders of the diesel engine.

[0014] Since the structure of the injector 8 for controlling injection by the opening/closing of the solenoid valve 8A is itself known, further detailed explanation of the structure of the injector 8 will be omitted here.

[0015] The high-pressure pump assembly 3 is constituted by integrally assembling a main high-pressure pump unit 31 driven by the diesel engine, a fuel metering unit 32 and an inlet/outlet valve 33. Fuel is supplied to the fuel metering unit 32 from a fuel tank 5 by a feed pump 6. The fuel metering unit 32 regulates the flow rate of the fuel supplied from the feed pump 6 to make the fuel pressure that required by the diesel engine and feeds the fuel to the inlet/outlet valve 33. The inlet/outlet valve 33 supplies the fuel received from the fuel metering unit 32 to a plunger chamber (not shown) of the high-pressure pump assembly 3 and supplies the fuel raised to a high pressure in the plunger chamber to the common rail 2 while preventing it from flowing back to the fuel metering unit 32. The regulation of the fuel flow rate in the fuel metering unit 32 is conducted by open/close control of a solenoid valve 34 provided in the fuel metering unit 32.

[0016] Designated by reference numeral 7 is a control unit, constituted using a microcomputer 7A, for controlling the different parts of the fuel injection apparatus 1 as explained later. The control unit 7 is input with an actual pressure signal U1 from a pressure sensor 2A that detects the fuel pressure in the common rail 2 (rail pressure). In addition, the control unit 7 is input by an RPM sensor 9A with an RPM signal U2 representing the engine speed of the diesel engine, by a coolant temperature sensor 9B with a coolant temperature signal U3 representing the coolant temperature of the diesel engine and by a fuel temperature sensor 9C with a fuel temperature signal U4 representing the temperature of the fuel supplied to the common rail 2; and the control unit 7 is further input by an accelerator sensor 9D with an accelerator signal U5 representing the amount of operation of an accelerator pedal (not shown).

[0017] The control unit 7 is configured to respond to the actual pressure signal U1, RPM signal U2, coolant temperature signal U3, fuel temperature signal U4 and accelerator signal U5 by outputting a second control signal M2 for open/close controlling the solenoid valve 34 so as to maintain the pressure of the high-pressure fuel accumulated in the common rail 2 at a required level.

[0018] The second control signal M2 output by the control unit 7 for open/close controlling the solenoid valve 34 is a pulse signal whose duty ratio is set in the control unit 7 to an output value for controlling the solenoid valve 34. This makes it possible to regulate the flow rate of the high-pressure fuel flowing to the common rail 2 from the main high-pressure pump unit 31, and this flow rate regulation makes it possible to control the pressure of the high-pressure fuel in the common rail 2 to the prescribed pressure. Since the configuration of the high-pressure pump assembly 3 whereby the solenoid valve 34 is open/close operated by such duty ratio control so as to conduct flow rate regulation of the fuel is itself known, detailed explanation regarding the high-pressure pump assembly 3 is omitted.

[0019] Structural details of the pressure booster 4 are shown in Fig. 2. The pressure booster 4 is a device of known structure configured such that a booster piston 45 composed of large-diameter piston 43 and a small-diameter piston 44 is housed in a cylinder chamber 42 within a main body 41 and a spring 46 spring-biases the booster piston 45 in the direction of the arrow X. It is configured to supply high-pressure fuel from the common rail 2 to a first chamber 42A divided off by the large-diameter piston 43 and to send pressure-boosted high-pressure fuel from a second chamber 42B divided off by the small-diameter piston 44 to the injector 8.

[0020] A third chamber 42C that houses the spring 46 communicates with the first chamber 42A through an orifice 43A formed in the large-diameter piston 43. The first chamber 42A and the second chamber 42B are connected through an oil duct 47A provided with a check valve 47 to form a configuration that enables high-pressure fuel to be passed only from the first chamber 42A to the second chamber 42B, whereby by the high-pressure fuel can be supplied from the first chamber 42A to the second chamber 42B. Further, the third chamber 42C is connected to the fuel low-pressure side by an oil duct 48A. This configuration enables the boosted pressure of the high-pressure fuel by the pressure booster 4 to be controlled by open/close controlling a control solenoid valve 48 provided in the oil duct 48A to regulate the fuel pressure in the third chamber 42C. The control solenoid valve 48 is constituted as an open/close valve and the close or open state of the control solenoid valve 48 is controlled in response to a third control signal M3 from the control unit 7. Since the structure of the pressure booster 4 shown in Fig. 2 is itself known, detailed explanation regarding the operation for boosting pressure will be omitted.

[0021] Fig. 3 shows a detailed configuration diagram of the control unit 7. In the control unit 7, 71 is an injection control section for controlling the injector 8, 72 is a rail pressure control section for controlling the rail pressure of the common rail 2, and 73 is a pressure booster control section for controlling the pressure booster 4. Each of the injection control section 71, rail pressure control section 72 and pressure booster control section

73 are input with the actual pressure signal U1, RPM signal U2, coolant temperature signal U3, fuel temperature signal U4 and accelerator signal U5 as input signals. The injection control section 71 is responsive to these input signals for computing/outputting an injection control signal C1 for controlling fuel injection from the injector 8, and the injection control signal C1 is fed to an injector power control section 71A; the injector power control section 71A outputs a first control signal M1 corresponding the injection control signal C1. Although explanation has been made here with regard to a single injector 8, actually multiple injectors are provided. While the same control is effected with respect to each injector, the details thereof are omitted.

[0022] In accordance with a conventional configuration, the rail pressure control section 72, which is a control section for controlling the fuel pressure in the common rail 2 to the optimum value, is responsive to the input signals for outputting a rail pressure control signal C2, and a high-pressure pump power control section 72A is responsive to the rail pressure control signal C2 for outputting the second control signal M2.

[0023] The pressure booster control section 73 is configured to be responsive to both the input signals and also the injection control signal C1 to output an open/close control signal C3 to a control solenoid valve power control section 73A; the control solenoid valve power control section 73A outputs the third control signal M3.

[0024] Explanation regarding the pressure booster control section 73 will now be made with reference to Fig. 4. Fig. 4 is a flowchart of a control program for controlling the pressure booster 4 that is executed in the microcomputer 7A of the control unit 7. The pressure booster control section 73 will be explained based on this flowchart. When execution of the control program is initiated, first, in step S1, the desired rail pressure, i.e., the desired pressure of the fuel in the common rail 2, is computed based on the input signals U2-U5. In the following step S2, the actual rail pressure, i.e., the actual fuel pressure in the common rail 2, is detected from the actual pressure signal U1. Then, in step S3, the pressure deviation ΔP between the actual value P_A and the desired value P_T of the fuel pressure in the common rail 2 ($= P_A - P_T$) is calculated, whereafter control passes to step S4.

[0025] In step S4, it is checked whether the pressure deviation ΔP is greater than a prescribed value K for discriminating rapid pressure decrease. The prescribed value K represents a discrimination reference pressure for discriminating whether or not rapid reduction of rail pressure is necessary because the rail pressure of the common rail 2 has come to greatly exceed the desired rail pressure for a reason such as that the accelerator pedal was abruptly released.

[0026] When $\Delta P \leq K$ in step S4, the discrimination result in step S4 is NO and control passes to step S5, in which the rail pressure control section 72 performs normal pressure control by duty ratio control of the solenoid

valve 34, and feedback control is performed to make the fuel pressure in the common rail 2 the desired value.

[0027] When $\Delta P > K$ in step S4, the discrimination result in step S4 is YES, a measure is initiated to rapidly reduce the fuel pressure in the common rail 2 by opening the control solenoid valve 48.

[0028] Specifically, in the fuel injection apparatus 1, when the rail pressure in the common rail 2 assumes a high-pressure state of over a prescribed level that makes rapid pressure reduction necessary, the control solenoid valve 48 used to control the boosted pressure in the pressure booster 4 is used for the purpose of rapid pressure reduction by spilling high-pressure fuel in the common rail 2 to the low pressure side. As can be seen from Fig. 2, when the control solenoid valve 48 is opened, the pressure of the third chamber 42C declines to spill high-pressure fuel supplied from the common rail 2 to the low pressure side through the first chamber 42A, orifice 43A and third chamber 42C, whereby the rail pressure can be reduced relatively rapidly.

[0029] The rapid pressure reduction by the control solenoid valve 48 needs to be performed by spilling the required amount at a time point where there is no adverse effect on the fuel injection operation of the injector 8 and the fuel injection operation of the other injectors that are not shown.

[0030] Therefore, a desired spill amount required for pressure reduction is calculated in response to the actual pressure signal U1 in step S6, the pressure reduction operation start time, i.e., the time point of the valve opening operation of the control solenoid valve 48 for pressure reduction, is computed in step S7, and the pressure reduction power application period, i.e., the valve-open period of the control solenoid valve 48 necessary to realize the desired spill amount, is computed in step S8.

[0031] In step S9, the open/close control signal C3 for pressure reduction by controlling the valve opening operation of the control solenoid valve 48 is output based on the computation results in the steps S6, S7 and S8. The open/close control signal C3 is sent to the control solenoid valve power control section 73A (see Fig. 3) and the control solenoid valve power control section 73A applies the third control signal M3 for opening/closing the control solenoid valve 48 in accordance with the open/close control signal C3 to the control solenoid valve 48. This reduces the fuel pressure in the common rail 2 at a stroke. As a result, the excessively high fuel pressure in the common rail 2 is lowered with excellent responsiveness so that the pressure in the common rail 2 can be brought to the required target value in a short time.

[0032] Next, the rapid rail pressure reduction operation using the pressure booster 4 will be explained with reference to Figs. 5A - 5C and Figs. 6A - 6C.

[0033] Figs. 5A - 5C are graphs showing an operation example in the case of not conducting rapid pressure reduction. Fig. 5A is a graph showing the open/close op-

eration of the control solenoid valve 48, Fig. 5B is a graph showing the fuel injection operation at the injector, and Fig. 5C is a graph showing the time-course change in the fuel injection from the injector, etc. Here, the control solenoid valve 48 is opened for a prescribed time period at time points TA, TB synchronously with fuel injection so as to lower the backpressure of the large-diameter piston 43 and, by this, boost the fuel pressure to increase the injection quantity at the late stage of each fuel injection. In this case, the rail pressure declines owing to the opening of the control solenoid valve 48 at time point TA but returns almost to the original level by the next time point TB, so that the injection quantity decrease $\Delta Q1$ at time point TB is very small.

[0034] On the other hand, Figs. 6A - 6C are graphs showing an operation example in the case of conducting rapid pressure reduction. Fig. 6A is a graph showing the open/close operation of the control solenoid valve 48, Fig. 6B is a graph showing the fuel injection operation at the injector, and Fig. 6C is a graph showing the time-course change in the fuel injection from the injector, etc. This is an example of the case where the control solenoid valve 48 is opened for the purpose of rapid pressure reduction at time points T1 and T2 where fuel injection from the injector at time points TA and TB is not affected. At time points T1 and T2, high-pressure fuel in the common rail 2 is allowed to escape to the low-pressure side through the control solenoid valve 48, whereby the rail pressure can be rapidly reduced. As a result, the injection quantity decrease $\Delta Q2$ at the next injection time point TB is larger than $\Delta Q1$ in the case of Fig. 5.

[0035] The example shown in Figs. 6A - 6C was explained regarding the case of conducting the operation for pressure reduction by opening the control solenoid valve 48 twice at the time points T1 and T2. However, the number of operations of the control solenoid valve 48 for pressure reduction operation can be any number of times insofar as no problem arises in the fuel injection operation by the injector and the amount of fuel spilled each time can be appropriately determined in view of the required pressure reduction.

[0036] In accordance with this configuration, it becomes possible to effectively reduce the pressure of the high-pressure fuel in the common rail 2 in a short time using the control solenoid valve 48 preinstalled in the pressure booster, merely by making minor changes to its control section configuration or to its program. Therefore, the configuration enables the rail pressure of the common rail 2 to be reduced more rapidly than heretofore despite its low cost. As a result, since any abrupt fuel injection termination operation that occurs can be prevented from giving rise to problems in the fuel injection operation thereafter, it is possible to realize a common rail fuel injection apparatus that is low in cost and high in performance.

INDUSTRIAL APPLICABILITY

[0037] As set out in the foregoing, the common rail fuel injection apparatus of the present invention is effective for preventing abrupt fuel injection termination operation from giving rise to problems in the fuel injection operation thereafter.

Claims

1. A common rail fuel injection apparatus configured so that high-pressure fuel from a common rail for accumulating fuel supplied under pressure from a fuel supply pump is sent through a pressure booster to an injector open/closed controlled by fuel injection control means and wherein pressure boost control in the pressure booster is conducted by using a solenoid valve to regulate an amount of the high-pressure fuel supplied to the pressure booster that is spilled to the low-pressure side, the common rail fuel injection apparatus being **characterized in that** it comprises:

discrimination means for discriminating whether reduction of fuel pressure in the common rail is necessary,

spill amount computing means for computing a high-pressure fuel spill amount necessary for pressure reduction when the discrimination means discriminates that pressure reduction is necessary, and

solenoid valve control means responsive to the spill amount computing means and the fuel injection control means for open/close controlling the control solenoid valve so as to spill the high-pressure fuel to the low-pressure side at a time point when fuel injection from the injector is not being conducted.

2. A common rail fuel injection apparatus as claimed in claim 1, wherein the control solenoid valve is open/close controlled so as to spill the high-pressure fuel to the low-pressure side for a prescribed time period at said time point.

3. A common rail fuel injection apparatus as claimed in claim 1, further comprising spill amount computing means for computing a high-pressure fuel spill amount necessary for pressure reduction,

the solenoid valve control means open/close controlling the control solenoid valve in response to the spill amount computing means and the fuel injection control means so as to spill said spill amount of the high-pressure fuel to the low-pressure side at a time point when fuel injection from the injector is not being con-

ducted.

4. A common rail fuel injection apparatus as claimed in claim 1, configured such that the discrimination means is equipped with desired pressure computing means for computing a desired pressure of the common rail and a rail pressure sensor for detecting actual pressure of the common rail and discriminates whether pressure reduction is necessary by comparing the desired pressure and the actual rail pressure.

5

10

15

20

25

30

35

40

45

50

55

FIG.1

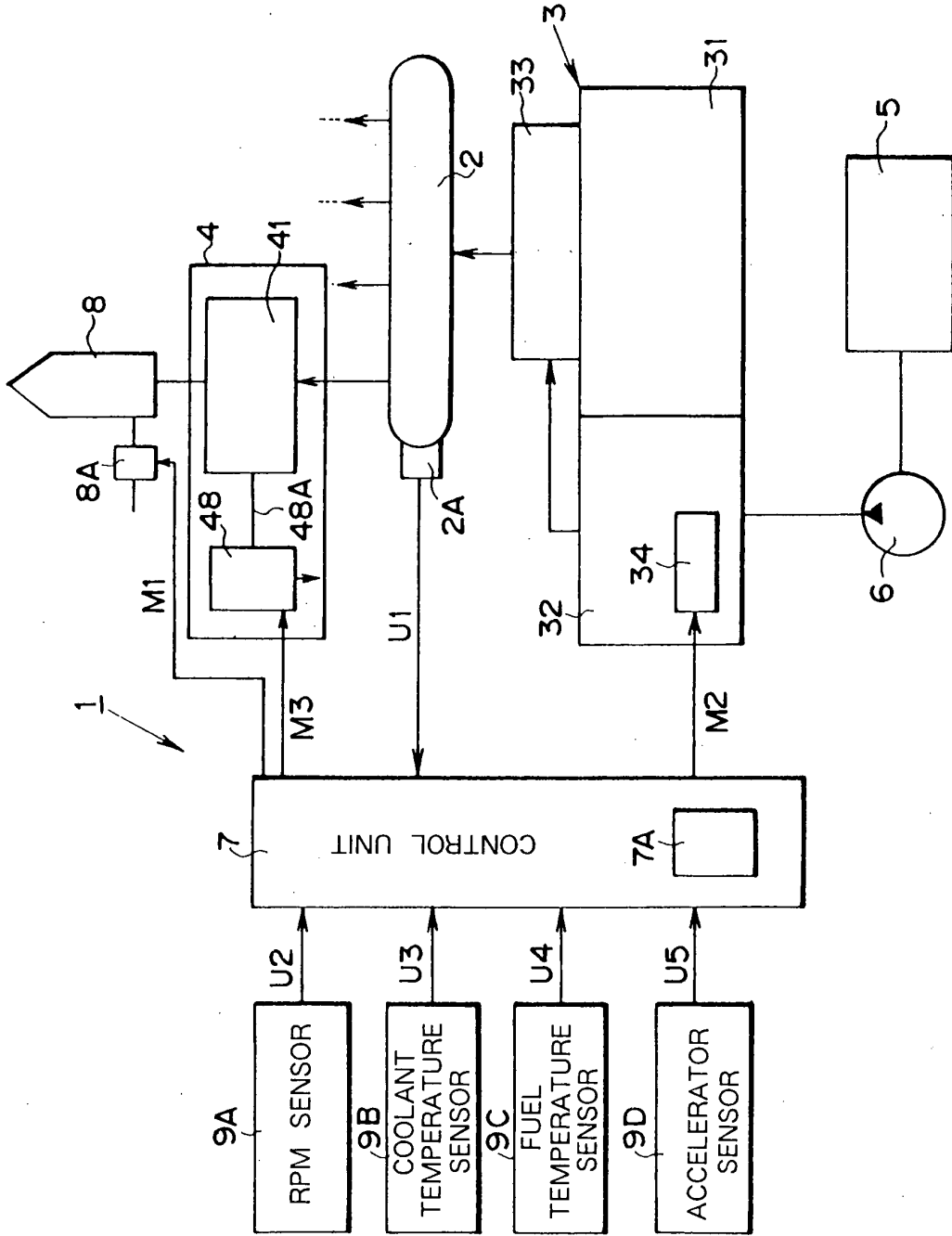

FIG.2

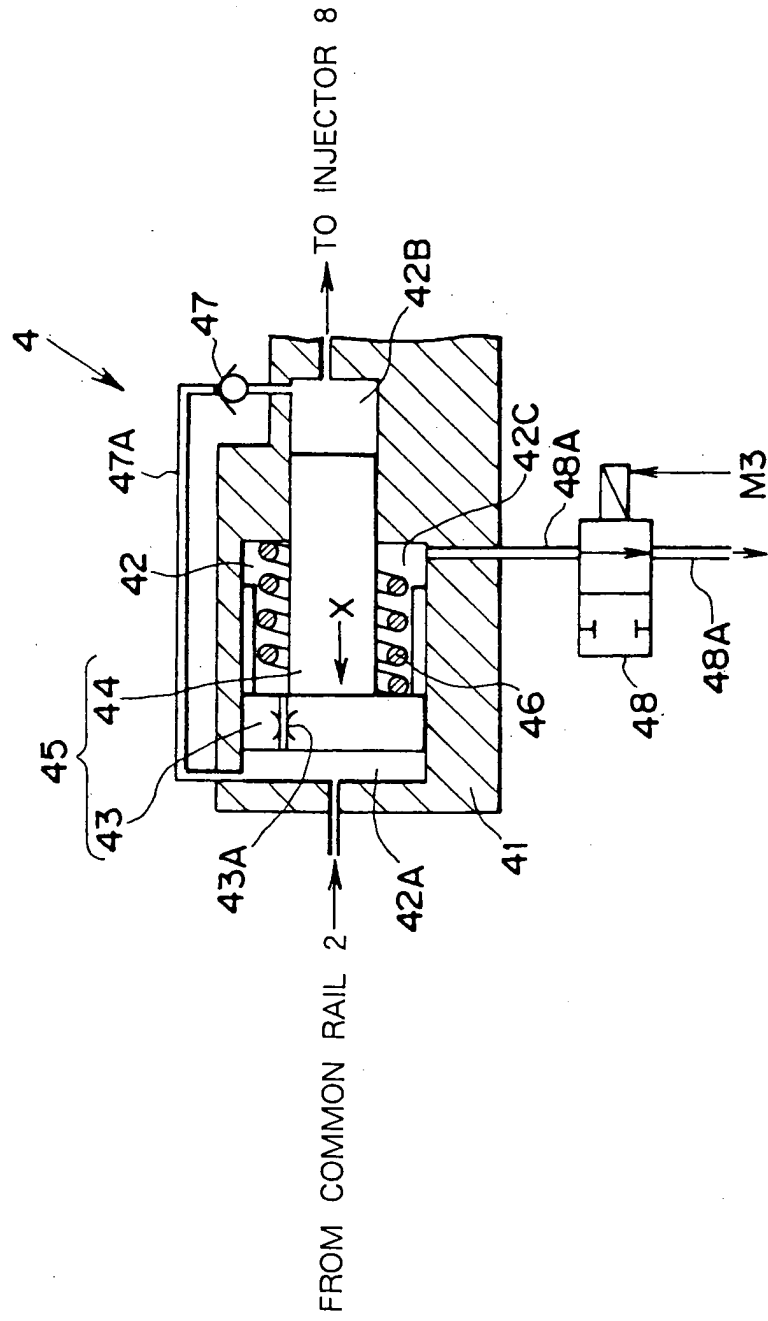

FIG.3

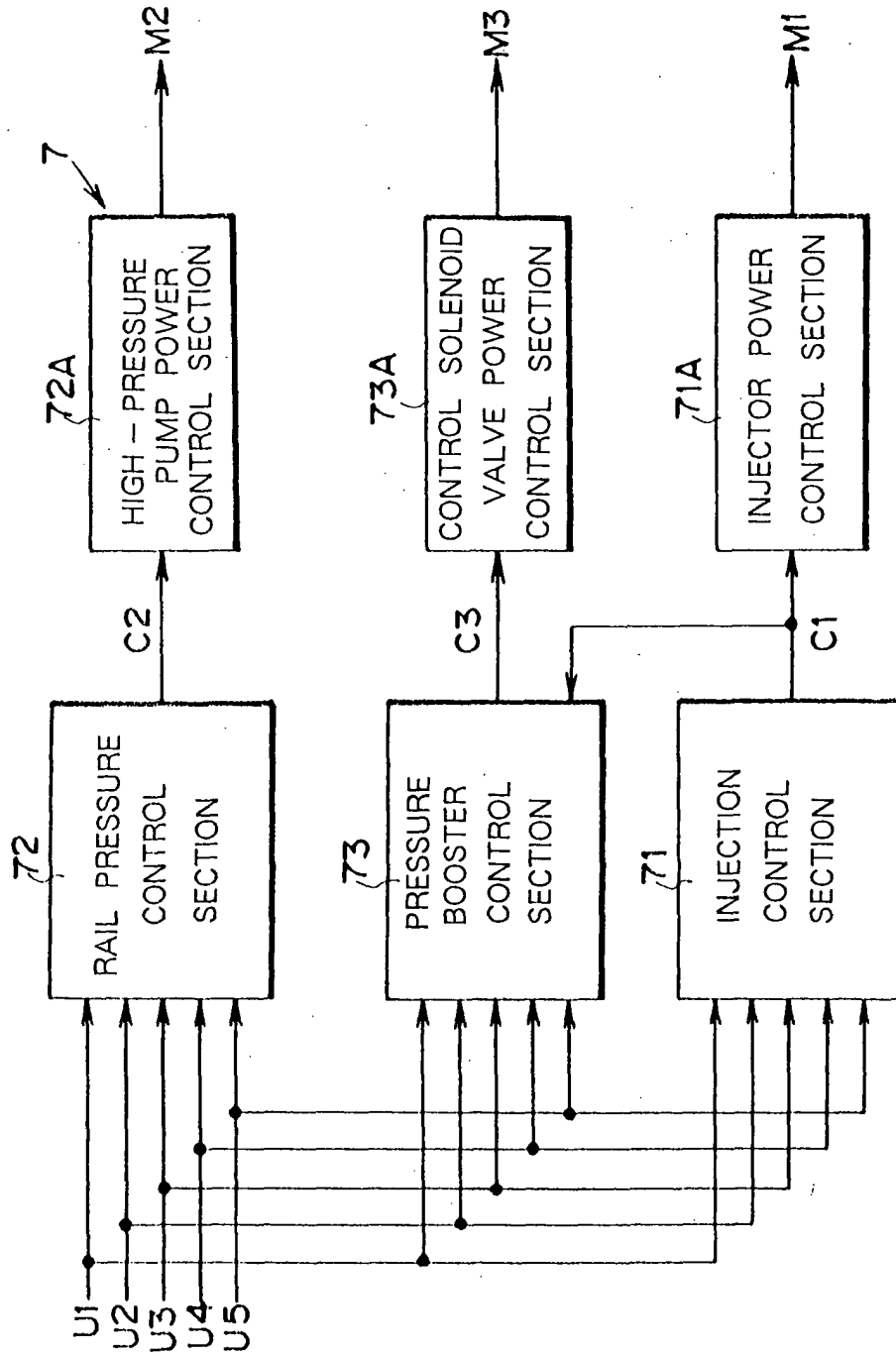
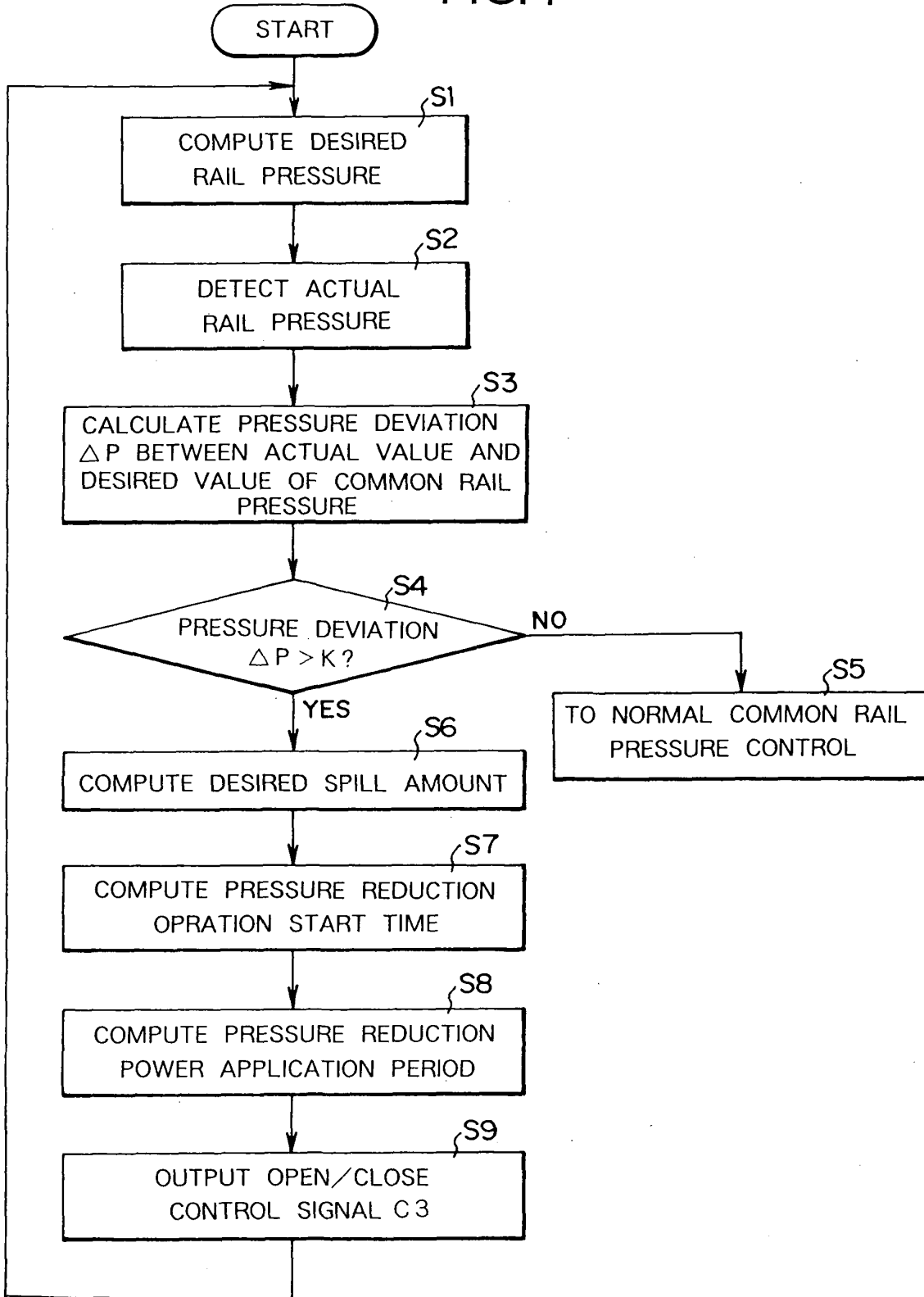
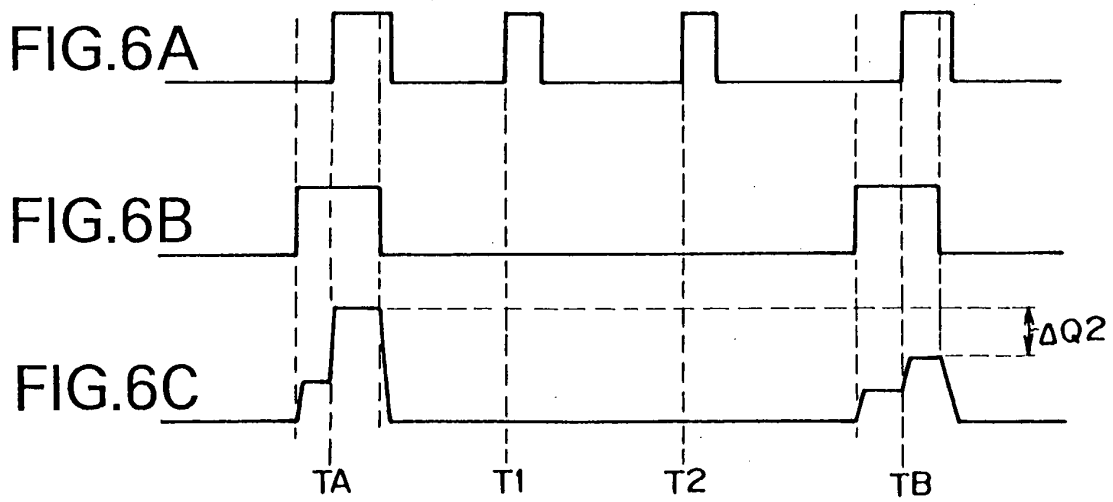
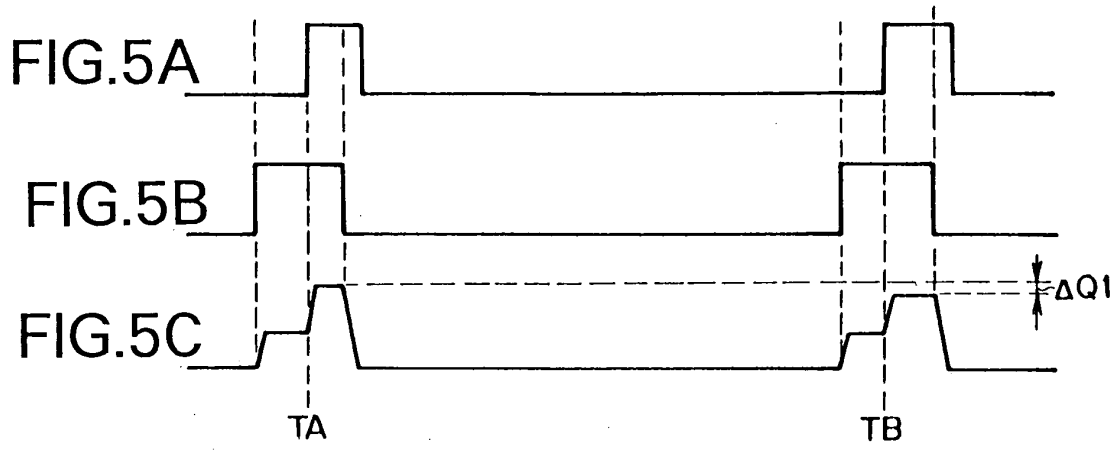

FIG.4





INTERNATIONAL SEARCH REPORT

International application No.

PCT/JP03/08275

A. CLASSIFICATION OF SUBJECT MATTER Int.Cl ⁷ F02M47/00, F02M55/02, F02D41/12, F02D41/38 According to International Patent Classification (IPC) or to both national classification and IPC		
B. FIELDS SEARCHED Minimum documentation searched (classification system followed by classification symbols) Int.Cl ⁷ F02M47/00, F02M55/02, F02D41/12, F02D41/38 Documentation searched other than minimum documentation to the extent that such documents are included in the fields searched Jitsuyo Shinan Koho 1922-1996 Jitsuyo Shinan Toroku Koho 1996-2003 Kokai Jitsuyo Shinan Koho 1971-2003 Toroku Jitsuyo Shinan Koho 1994-2003 Electronic data base consulted during the international search (name of data base and, where practicable, search terms used)		
C. DOCUMENTS CONSIDERED TO BE RELEVANT		
Category*	Citation of document, with indication, where appropriate, of the relevant passages	Relevant to claim No.
A	WO 01/52916 A2 (ROBERT BOSCH GMBH.), 26 July, 2001 (26.07.01), Full text; all drawings & DE 10002273 A & EP 1252437 A & JP 2003-520317 A	1-4
A	WO 00/55496 A1 (ROBERT BOSCH GMBH.), 21 September, 2000 (21.09.00), Full text; all drawings & DE 19910970 A & EP 1078160 A & JP 2002-539372 A	1-4
A	JP 2-191865 A (Nippondenso Co., Ltd.), 27 July, 1990 (27.07.90), Full text; all drawings (Family: none)	1-4
<input checked="" type="checkbox"/> Further documents are listed in the continuation of Box C. <input type="checkbox"/> See patent family annex.		
* Special categories of cited documents: "A" document defining the general state of the art which is not considered to be of particular relevance "E" earlier document but published on or after the international filing date "L" document which may throw doubts on priority claim(s) or which is cited to establish the publication date of another citation or other special reason (as specified) "O" document referring to an oral disclosure, use, exhibition or other means "P" document published prior to the international filing date but later than the priority date claimed		"T" later document published after the international filing date or priority date and not in conflict with the application but cited to understand the principle or theory underlying the invention "X" document of particular relevance; the claimed invention cannot be considered novel or cannot be considered to involve an inventive step when the document is taken alone "Y" document of particular relevance; the claimed invention cannot be considered to involve an inventive step when the document is combined with one or more other such documents, such combination being obvious to a person skilled in the art "&" document member of the same patent family
Date of the actual completion of the international search 30 September, 2003 (30.09.03)		Date of mailing of the international search report 21 October, 2003 (21.10.03)
Name and mailing address of the ISA/ Japanese Patent Office Facsimile No.		Authorized officer Telephone No.

Form PCT/ISA/210 (second sheet) (July 1998)

INTERNATIONAL SEARCH REPORT

International application No.

PCT/JP03/08275

C (Continuation). DOCUMENTS CONSIDERED TO BE RELEVANT		
Category*	Citation of document, with indication, where appropriate, of the relevant passages	Relevant to claim No.
A	EP 1024274 A2 (DENSO CORP.), 02 August, 2000 (02.08.00), Full text; all drawings & JP 2000-282998 A	1-4
A	JP 63-117147 A (Toyota Motor Corp.), 21 May, 1988 (21.05.88), Full text; all drawings (Family: none)	1-4

Form PCT/ISA/210 (continuation of second sheet) (July 1998)