

Aug. 11, 1925.

1,549,402

T. H. WITTLIFF  
FURNITURE CONSTRUCTION  
Filed April 23, 1925

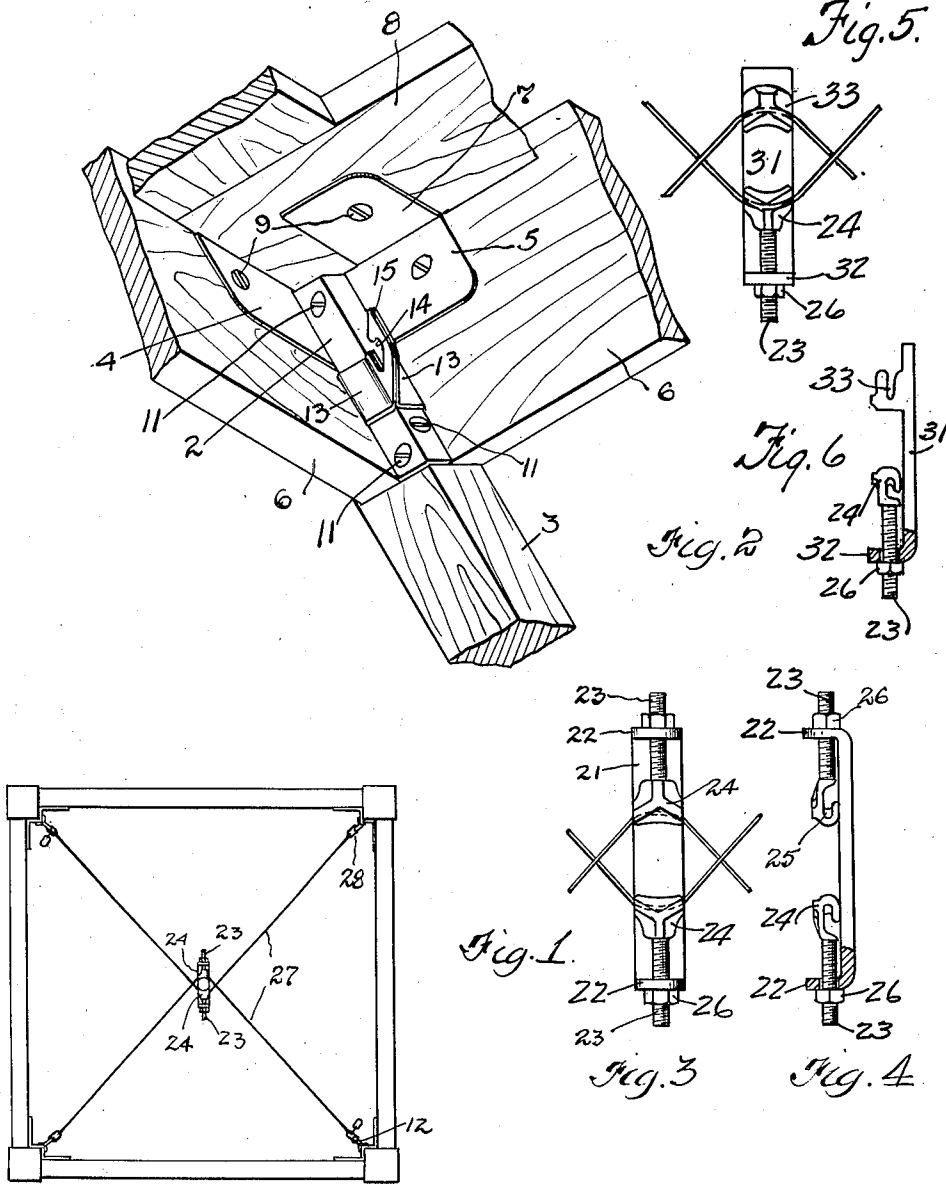

INVENTOR.  
*Theodore H. Wittliff.*  
BY  
*Fay, Oberlin & Fay*  
ATTORNEYS.

# UNITED STATES PATENT OFFICE.

THEODORE H. WITTLIFF, OF CLEVELAND, OHIO.

FURNITURE CONSTRUCTION.

Application filed April 23, 1925. Serial No. 25,343.

*To all whom it may concern:*

Be it known that I, THEODORE H. WITTLIFF, a citizen of the United States, and a resident of Cleveland, county of Cuyahoga, and State of Ohio, have invented a new and useful Improvement in Furniture Construction, of which the following is a specification, the principle of the invention being herein explained and the best mode in which I have contemplated applying that principle, so as to distinguish it from other inventions.

This invention relates to furniture construction. More particularly it comprises means for securing the side and corner members of an article of furniture to each other without the use of glue or the usual corner blocks and other fastening elements. The device is also adapted to use as a reinforcing means for articles of furniture, having its members secured in the usual manner, but omitting the corner blocks.

Chairs, bedsteads, and other articles of furniture of similar character, when the frame members thereof are secured by means of glue, are frequently found to become loosened and to develop a considerable degree of lost motion which causes such furniture to squeak as well as to give to the user thereof an uncomfortable sense of insecurity.

The present invention provides means of fastening the structural elements of such articles of furniture to each other in an improved manner so that any lost motion between the parts may be taken up, and which, at the same time, results in greater economy of construction and a more rigid connection between the several portions of the frame than can otherwise be obtained.

The annexed drawing and the following description set forth in detail certain mechanism embodying the invention, such disclosed means constituting, however, but one of various mechanical forms in which the principle of the invention may be used.

In said annexed drawing:—

Fig. 1 is a bottom plan view of a chair construction in accordance with the invention; Fig. 2 is a perspective view showing in enlarged detail one of the corner plates employed in the construction; Fig. 3 is an enlarged detail plan view showing one form of tensioning element employed; Fig. 4 is a side elevation partially in section of said tensioning element; Fig. 5 is an enlarged de-

tail plan view of another form of tensioning device; and Fig. 6 is a side elevation of the device shown in Fig. 5.

As is shown in the drawing the advantages of economy and rigidity of construction hereinabove referred to are obtained by using in place of the usual corner blocks employed in various articles of furniture, a sheet metal plate 1 having an angular central portion 2 adapted to fit over the inner edge of the corner post 3 of an article of furniture, and having adjacent its upper portion lateral wing extensions 4 and 5, at right angles thereto, adapted to be firmly secured to the side frame members 6 of the article of furniture. At the upper edge of one of the lateral wings, an integral extension 7 is provided, said extension projecting inwardly at right angles to its adjacent wing 5 and being adapted to support the seat or top portion 8 of the article of furniture.

Screws or other fastening devices 9 are used to secure the wings and extensions to the adjacent frame members. Other screws or fastening devices 11 are set into the corner post through holes formed at spaced intervals in the respective sides of the central angle portion 2 of the plate, and thus extend at right angles to each other.

The angular central portion of the plate, as shown in Fig. 2, preferably covers the inner edge of the corner post over the full width of the side frame members, although its lateral wings are preferably provided only adjacent its upper portion. Adjacent the central portion of the angle section means for the attachment of the end of one of the flexible members of the tensioning device is provided. This means may comprise a hook 12 firmly attached to the edge of the plate, as shown in Fig. 1, or may be formed of integral portions of the angle section. As is shown in Fig. 2, the fastening means for the tensioning device comprises two lateral extensions 13 bent rearwardly at each side of the angle section and pressed together so as to project diagonally inward. Curved slots 14 are cut in one side edge of said inwardly projecting lugs to form a hook 15 with which the end of one of the flexible members of the tensioning device may be engaged.

The tensioning device preferably comprises a base plate 21, having its ends 22 turned upwardly and provided with aper-

60

65

70

75

80

85

90

95

100

105

110

tures to receive the shanks of screw-bolts 23. Said screw-bolts are each provided with hook-shaped head portions 24 providing curved transverse grooves 25 within which the flexible members extending to the corner posts of an article of furniture are adapted to frictionally engage. Each of the screw-threaded shanks of said bolts is placed through one of the upturned ends of said body member so as to project in an outward direction, and an adjusting nut 26 is engaged thereover in a position to abut against the end face of said upturned portion of the body. A pair of flexible members, such as wire cables 27 having loops 28 formed at their free ends, are engaged at their end portions with the hooks 12 of the corner plates and have their intermediate portions engaged with the respective transverse grooves of the hook-shaped head portions of the tensioning device. It will be noted, as is shown in Fig. 3, that the flexible elements cross each other at a central point beneath the article of furniture and that the cables are crossed in opposite directions above one another on opposite sides of said tensioning device. This arrangement results in holding the tensioning device rigidly beneath the article of furniture so that the desired degree of tension may be placed upon the flexible members.

When the tensioning device is operated, the corner posts will be drawn inwardly against the side members and hold the same in rigid relation. Owing to the different directions in which the screws are placed, a high degree of tension may be applied without danger of separating the plates from their adjacent frame members.

It will be noted that the form of device shown in Fig. 2 may be stamped from sheet metal of the proper thickness and may be cheaply manufactured and easily applied. The usual corner blocks are dispensed with and in place thereof fastening elements are supplied which make it possible to compensate for any lost motion between the parts of an article which may develop through the drying out of the wood or through severe or long continued use.

Where a lesser degree of adjustment is adequate for the tensioning device, the same may be formed, as shown in Figs. 5 and 6 of the drawing, wherein the base plate 31 is provided with one upturned end 32 similar to the device shown in Figs. 3 and 4, and at the opposite end is provided with a stationary outwardly-turned hook-shaped head 33, having a curved transverse groove within which one of the flexible members extending to the corner posts of the article of furniture is adapted to frictionally engage. A screw-bolt, identical with those described in connection with Figs. 3 and 4, is adapted to engage through an aperture in the up-

turned end 32 of the modified form of base plate. The adjustment for the entire device is, of course, made only from one end.

Other modes of applying the principle of my invention may be employed instead of the one explained, change being made as regards the mechanism herein disclosed, provided the means stated by any of the following claims or the equivalent of such stated means be employed.

I therefore particularly point out and distinctly claim as my invention:—

1. An article of the character described, having in combination a plurality of corner posts, side frame members positioned between adjacent corner posts, fastening elements engaging said corner posts and said side frame members to hold said parts in rigid engagement with each other, and a hook on said respective fastening elements formed of a pair of integral rearwardly pressed lateral extensions of said fastening elements whereby they may be directly interconnected with each other.

2. An article of the character described, having in combination a plurality of corner posts, side frame members positioned between adjacent corner posts, the faces of each corner post adjacent the inner corner thereof lying inwardly of the point of junction of said side frame members therewith, fastening elements engaging said corner posts and said exposed inner faces of each of such side frame members to hold said parts in rigid engagement with each other, a hook formed of a pair of integral rearwardly pressed lateral extensions of said fastening elements, and means for interconnecting said hooks.

3. An article of the character described, having in combination a plurality of corner posts, side and top frame members positioned between adjacent corner posts, the faces of each corner post adjacent the inner corner thereof lying inwardly of the point of junction of said side frame members therewith, fastening elements engaging said exposed inner faces of each of such corner posts, and the side, and top frame members to hold said parts in rigid engagement with each other, a hook formed of a pair of integral rearwardly pressed lateral extensions of said fastening elements whereby they may be interconnected with each other.

4. A tensioning device for a furniture brace comprising a solid base plate, an integral extension at one end thereof positioned at right angles to the body portion of said base plate and provided with a central aperture, a cable-engaging member rigidly mounted on said plate and spaced from said plate extension, a movable member having a terminal designed to engage a cable and an integral screw-threaded shank of a size to pass freely through said aperture in

said base plate extension, and means bearing against said plate extension and engaging said screw-threaded shank to change the position of said movable cable-engaging member relatively to said fixed cable-engaging member.

5 5. A tensioning device for a furniture brace comprising a solid base plate, an integral extension at one end thereof positioned at right angles to the body portion of said base plate and provided with a central aperture, a cable-engaging member of V-shape rigidly mounted on said plate and spaced from said plate extension, a 10 movable member of V-shape having a terminal designed to engage a cable and an integral screw-threaded shank of a size to pass freely through said aperture in said base plate extension, and means bearing against 15 said plate extension and engaging said screw-threaded shank to change the position of said movable cable-engaging member relatively to said fixed cable-engaging member.

25 6. A tensioning device for a furniture brace comprising a solid base plate, an integral extension at one end thereof positioned at right angles to the body portion of said base plate and provided with a central aperture, a grooved outwardly faced cable-engaging member rigidly mounted on said plate and spaced from said plate exten-

sion, a grooved inwardly faced movable member having a terminal designed to engage a cable and an integral screw-threaded shank of a size to pass freely through said aperture in said base plate extension, and means bearing against said plate extension and engaging said screw-threaded shank to change the position of said movable cable-engaging member relatively to said fixed cable-engaging member.

7. A tensioning device for a furniture brace comprising a solid base plate, an integral extension at one end thereof positioned at right angles to the body portion of said base plate and provided with a central aperture, a cable-engaging member, having a friction groove, rigidly mounted on said plate and spaced from said plate extension, a movable member having a terminal having a friction groove designed to engage a cable and provided with an integral screw-threaded shank of a size to pass freely through said aperture in said base plate extension, and a rotatable nut bearing against said plate extension and adjustable on said screw-threaded shank to change the position of said movable cable-engaging member relatively to said fixed cable-engaging member.

Signed by me this 14 day of April, 1925.

THEODORE H. WITTLIFF.